

CONSOLE TABLE ASSEMBLY INSTRUCTIONS

A. TOP 1PC

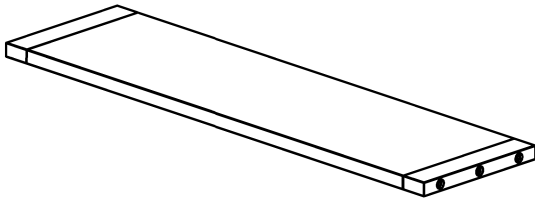

B. LEG LEFT 1PC

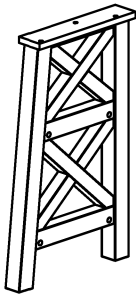

C. LEG RIGHT 1PC

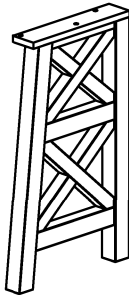

CONSOLE TABLE
ASSEMBLED

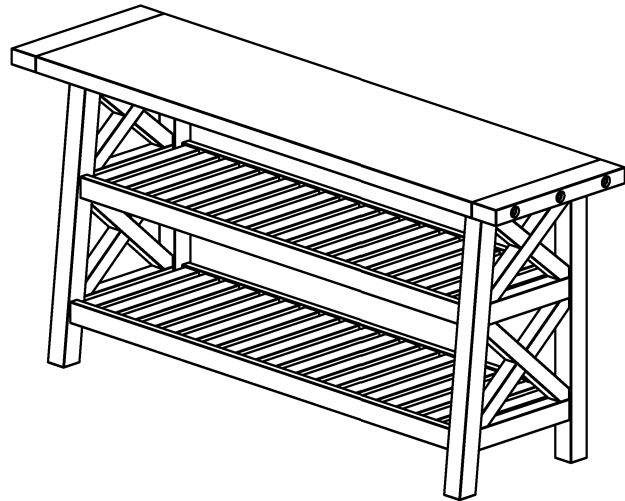



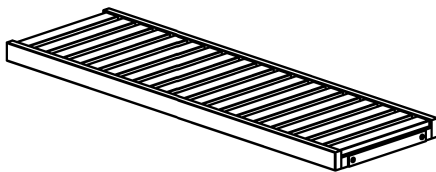

D. TOP SHELF 1PC

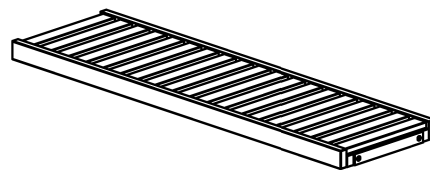

E. BOTTOM SHELF 1PC



HARDWARE ENCLOSED IN BOX

1	ALLEN BOLT M8 x 40 MM	14 PC	2	WASHER M9/22	14 PCS	3	SPRING WASHER M9/11	14 PCS	4	ALLEN KEY N4	01 PC
											

TOOL REQUIRED

PHILLIPS HEAD SCREW
DRIVER NOT PROVIDED



STEP 1:

ON A FLAT, LEVEL AREA LAY DOWN A CLEAN BLANKET OR TOWEL AND PLACE THE TABLE TOP (A) TOPSIDE DOWN. FOLLOWING THE ILLUSTRATION, ATTACH THE LEFT TABLE LEG (B) TO THE TOP USING THREE ALLEN BOLTS (1), SPRING WASHERS (3) AND FLAT WASHERS (2). DO NOT TIGHTEN BOLTS COMPLETELY.

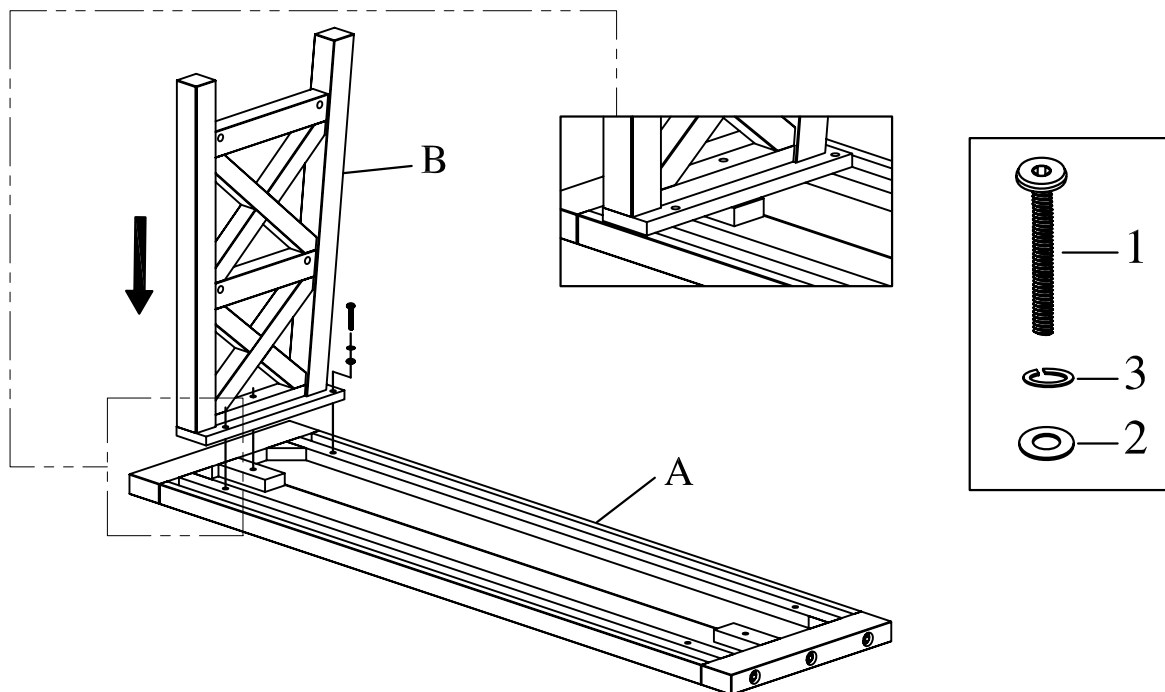

STEP 2:

ATTACH THE RIGHT TABLE LEG (C) TO THE TOP USING THREE ALLEN BOLTS (1), SPRING WASHERS (3) AND FLAT WASHERS (2). DO NOT TIGHTEN BOLTS COMPLETELY.

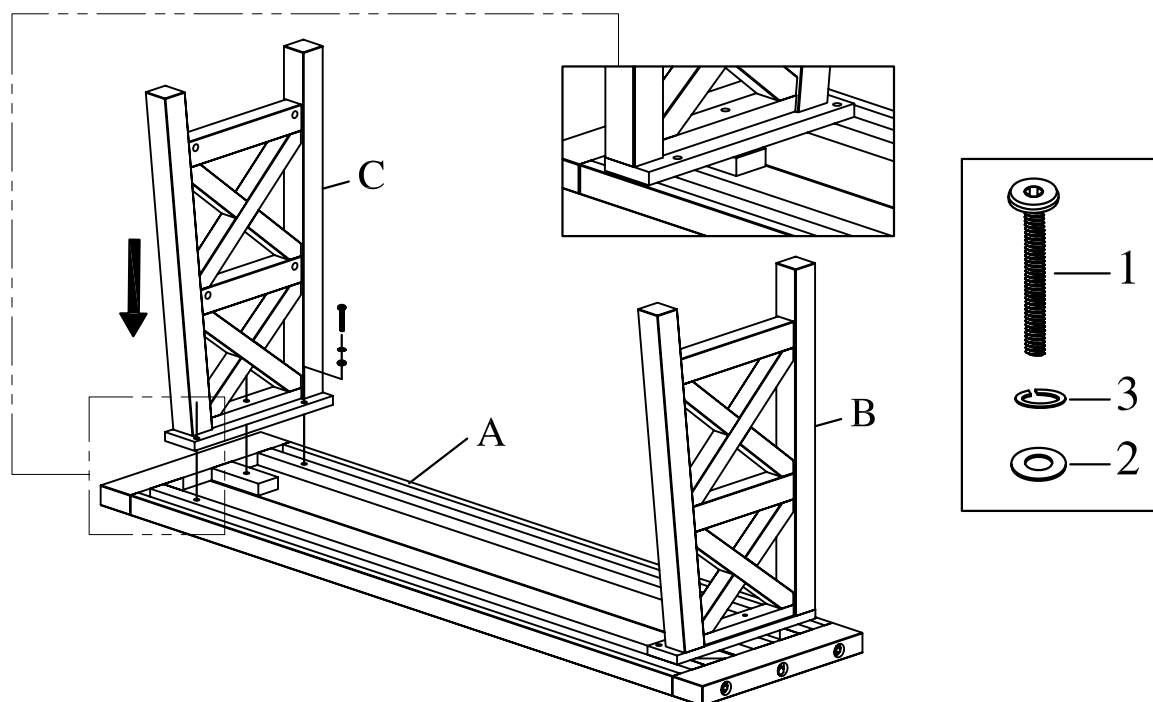

STEP 3:

CONNECT THE TOP SHELF (D) TO THE LEGS USING FOUR ALLEN BOLTS (1), SPRING WASHERS (3) AND FLAT WASHERS (2); TWO PER SIDE. TIGHTEN THE SHELF BOLTS COMPLETELY USING THE PROVIDED ALLEN KEY (4).

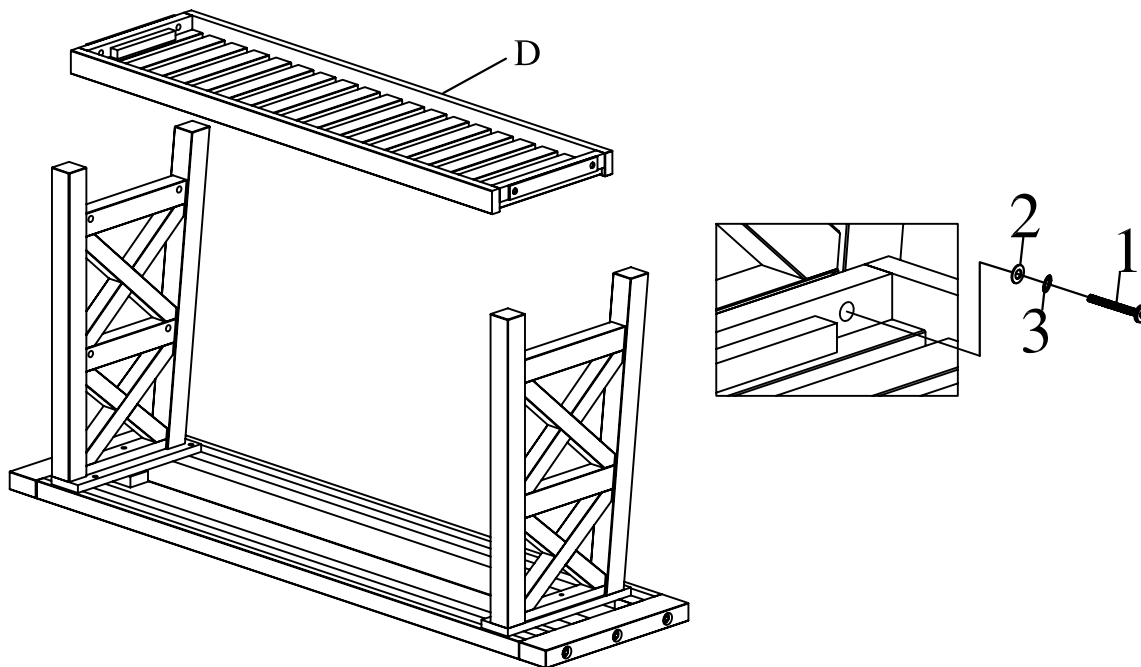

STEP 4:

CONNECT THE BOTTOM SHELF (E) TO THE LEGS USING FOUR ALLEN BOLTS (1), SPRING WASHERS (3) AND FLAT WASHERS (2); TWO PER SIDE. TIGHTEN THE SHELF BOLTS COMPLETELY USING THE PROVIDED ALLEN KEY (4). AFTER TIGHTENING THE BOTTOM SHELF BOLTS, COMPLETELY TIGHTEN THE SIX BOLTS USED TO ATTACH THE LEGS TO THE TABLE TOP.

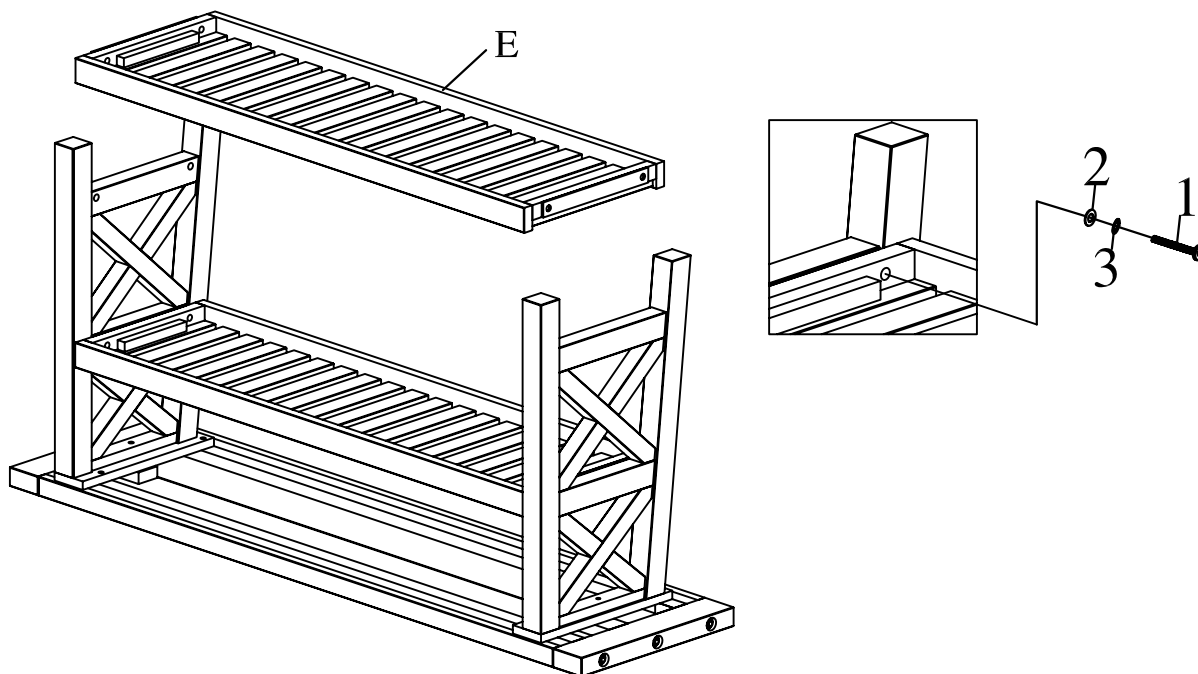

STEP 5:

WITH HELP FROM ANOTHER PERSON, FLIP THE COMPLETED CONSOLE TABLE RIGHT SIDE UP BEFORE USING.

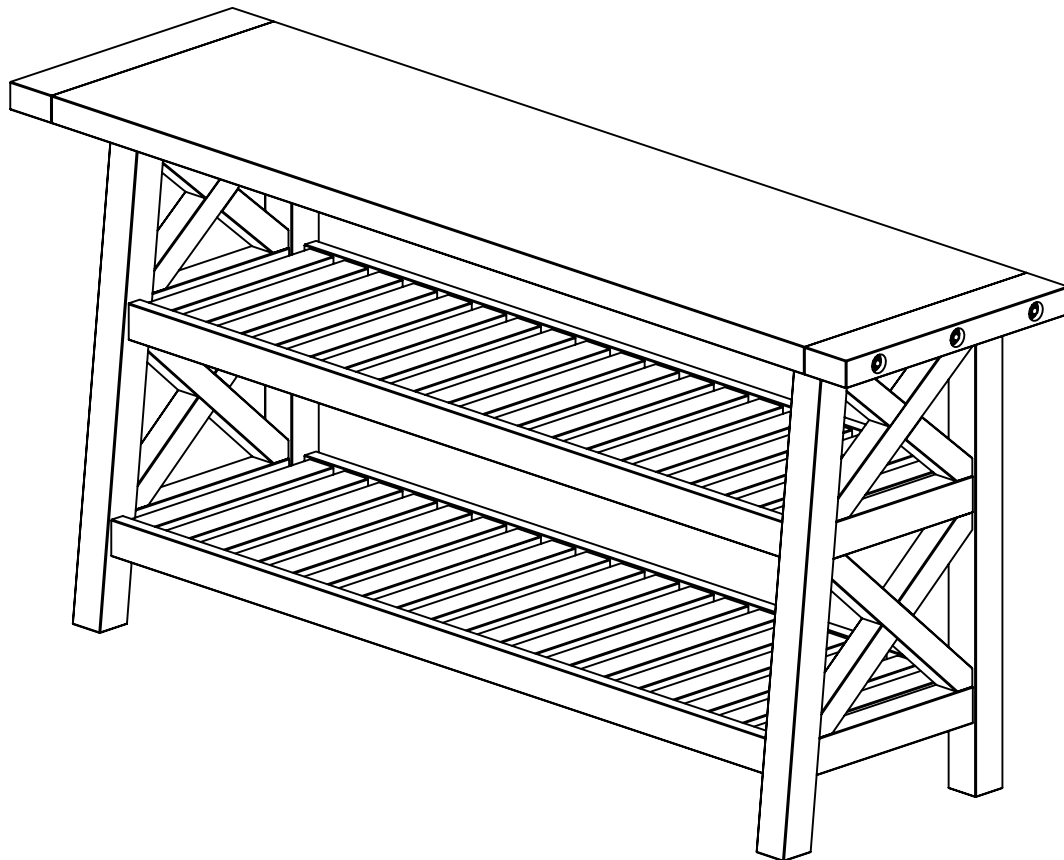

ASSEMBLY COMPLETE.