



ASSEMBLY INSTRUCTION FOR CASPIAN MEDIA CONSOLE

A		Tipping Hardware	1 PC
B		Screwdrivers (Not included)	1 PC



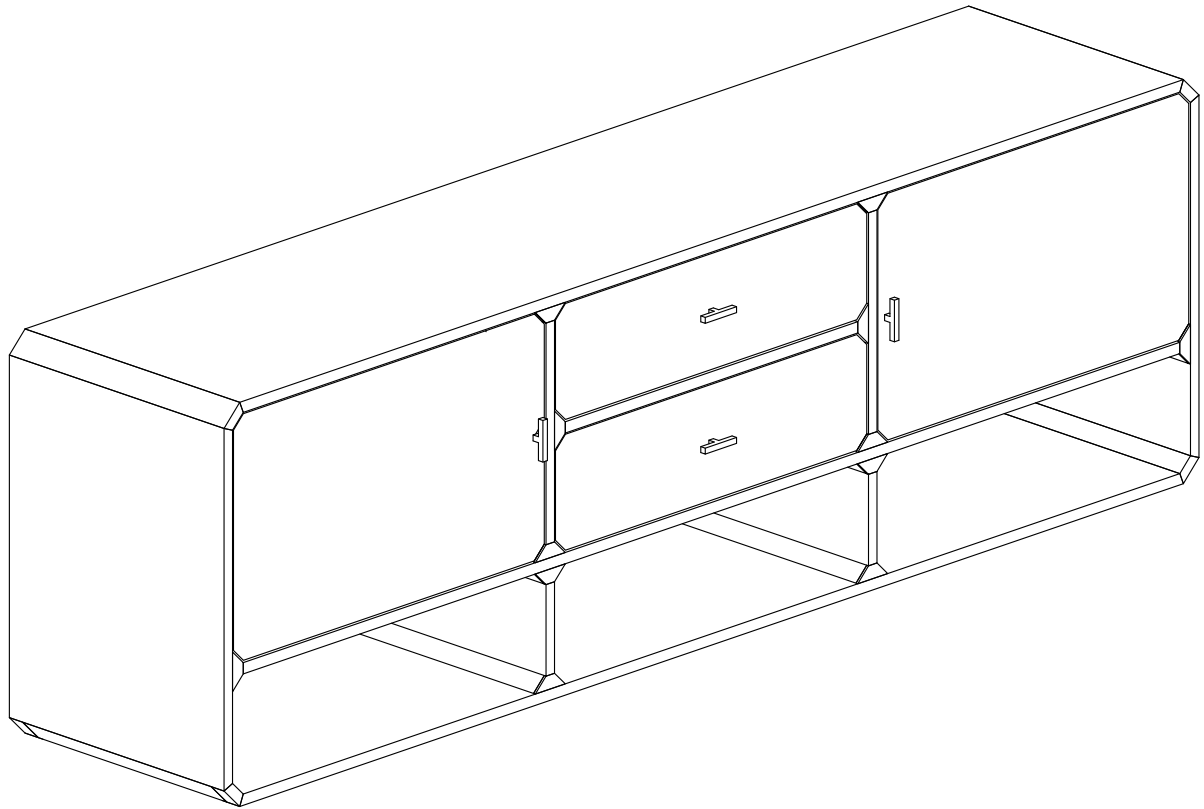
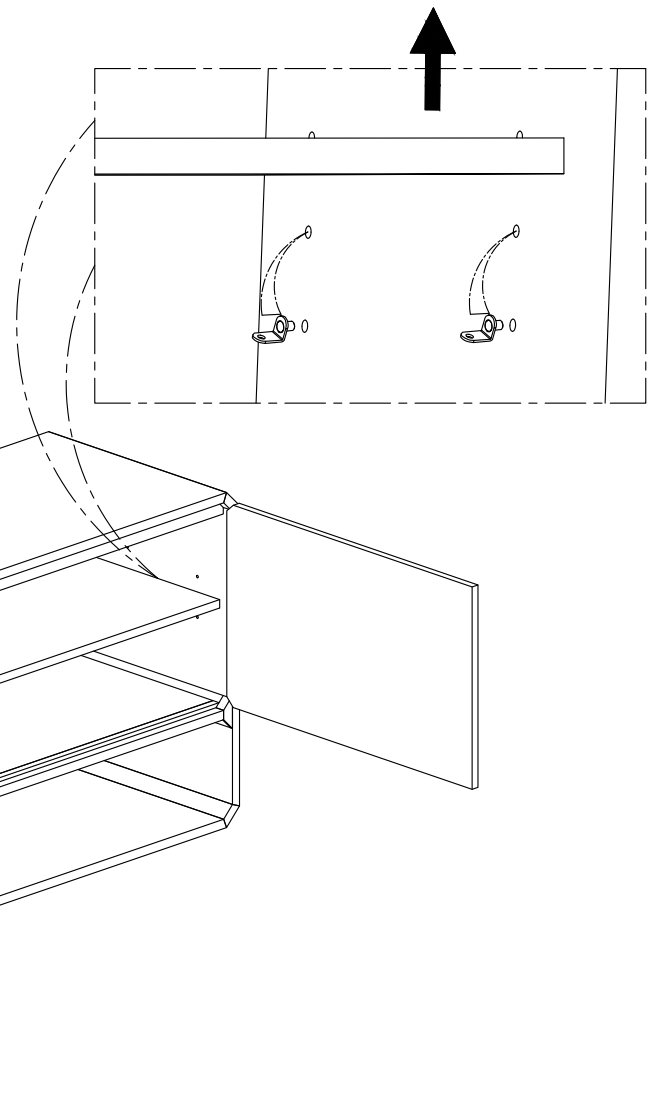
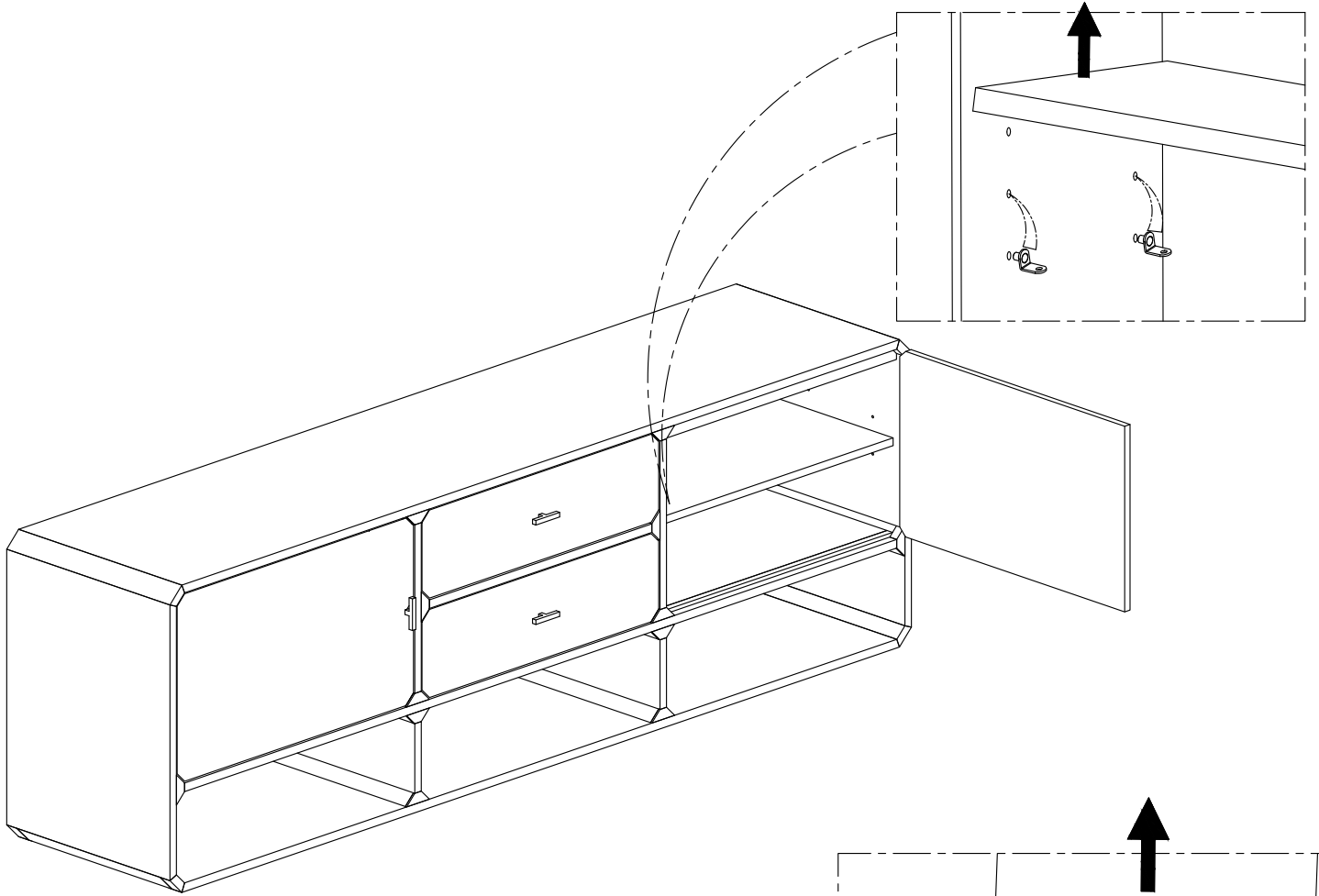

Tipping Hardware

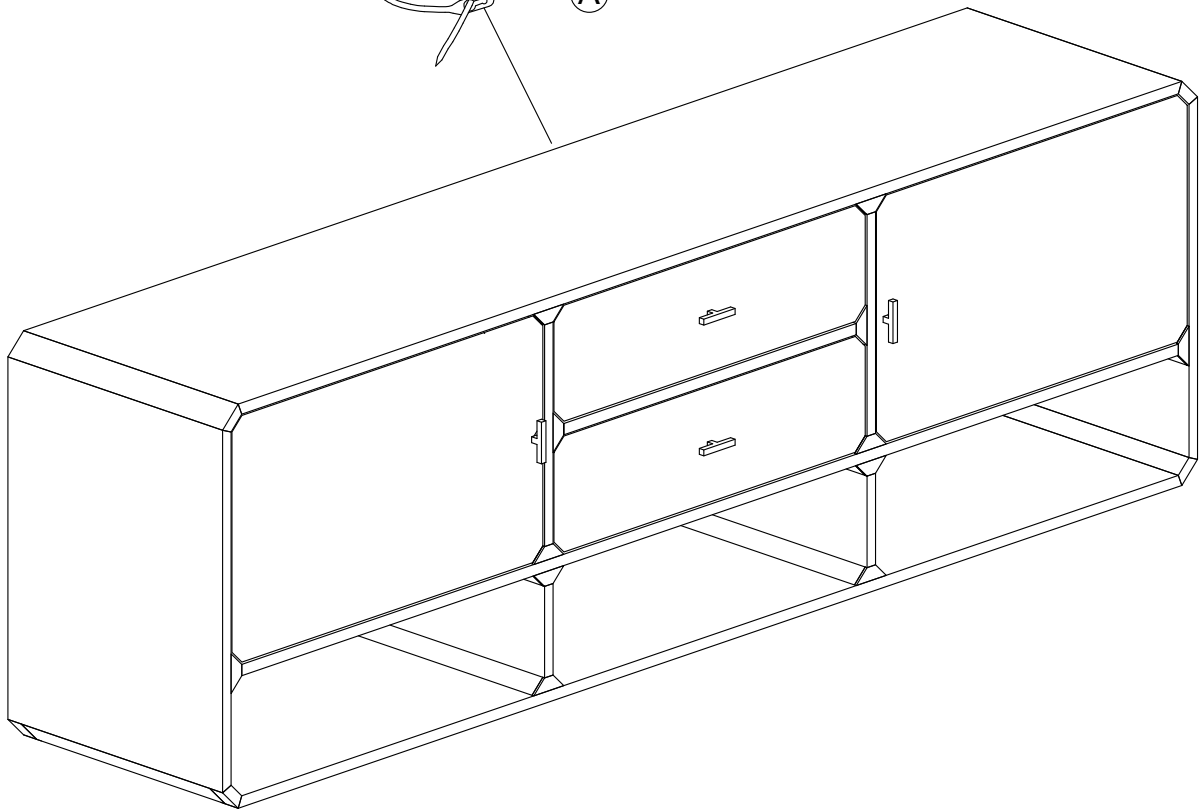
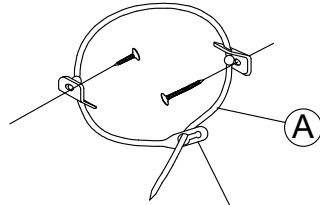

Adjusting Floor Levelers

Your furniture has been expertly crafted and pre-adjusted by professionals. However, slight shifts can occur during transportation. If you notice that the doors are not perfectly aligned or the furniture wobbles, a quick adjustment can help ensure stability and a seamless look.

Adjust the Floor Levelers

Check for Stability - Place the furniture in its final position on a level surface. If it wobbles or doesn't sit evenly, the floor levelers need adjusting.

Locate the Levelers - These are small adjustable feet found at the bottom corners of your furniture.

Adjust as Needed - Using your hand or a wrench, turn the levelers clockwise to raise or counterclockwise to lower the furniture. Make small adjustments and check stability after each turn.

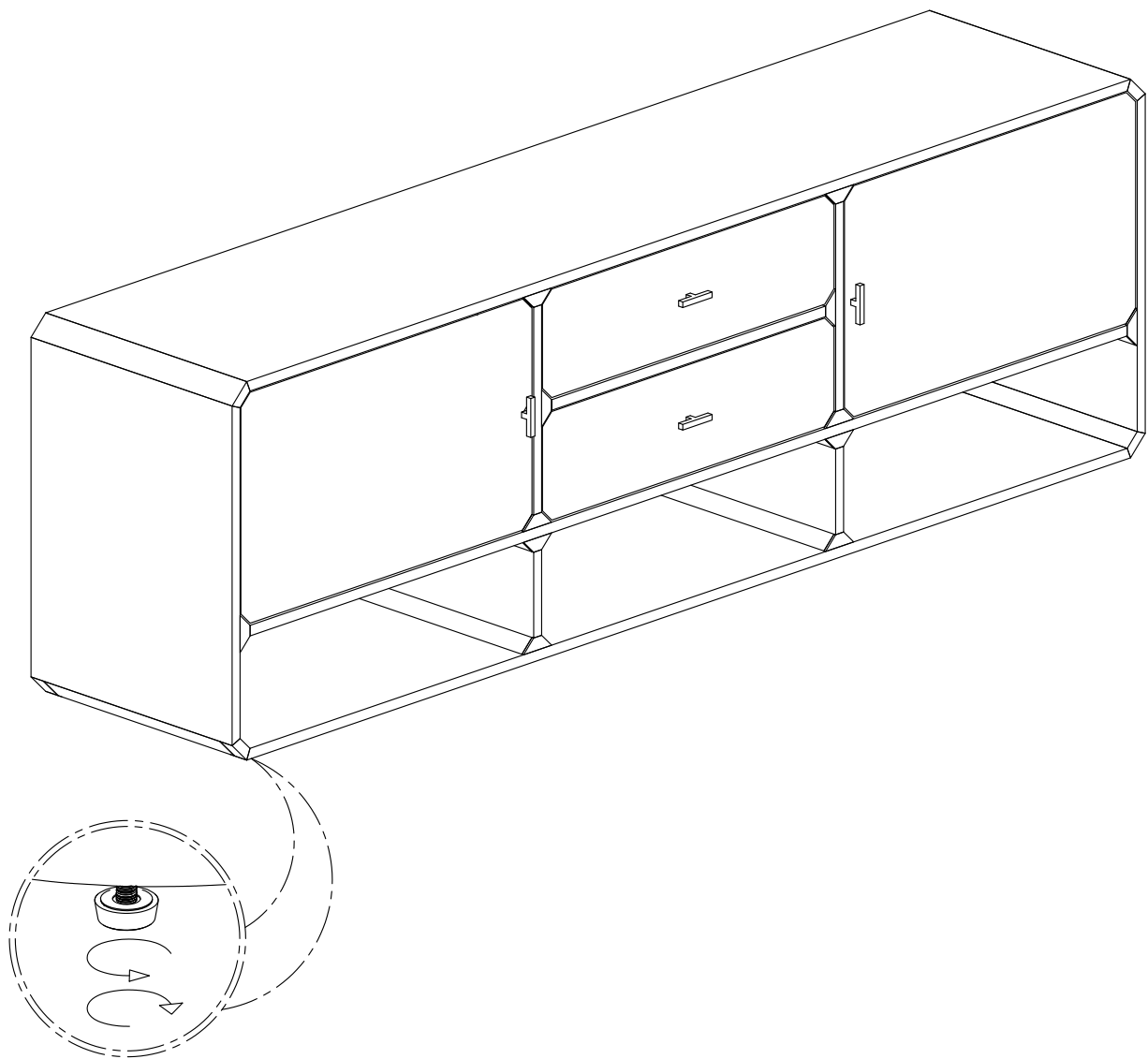

If you need further adjustments, repeat the process in small increments.

Adjust the Hinges (If Necessary)

Once the furniture is level, check the doors. If they appear misaligned or don't close properly: Make sure that the furniture is level left to right and front to back before attempting to adjust the hinges

Identify the Hinges - The hinges have adjustment screws that control movement in different directions.

1. Back and Forth Adjustment: To move the cabinet door closer to or farther from the cabinet frame
2. Left and Right Adjustment: To shift the cabinet door sideways for alignment.

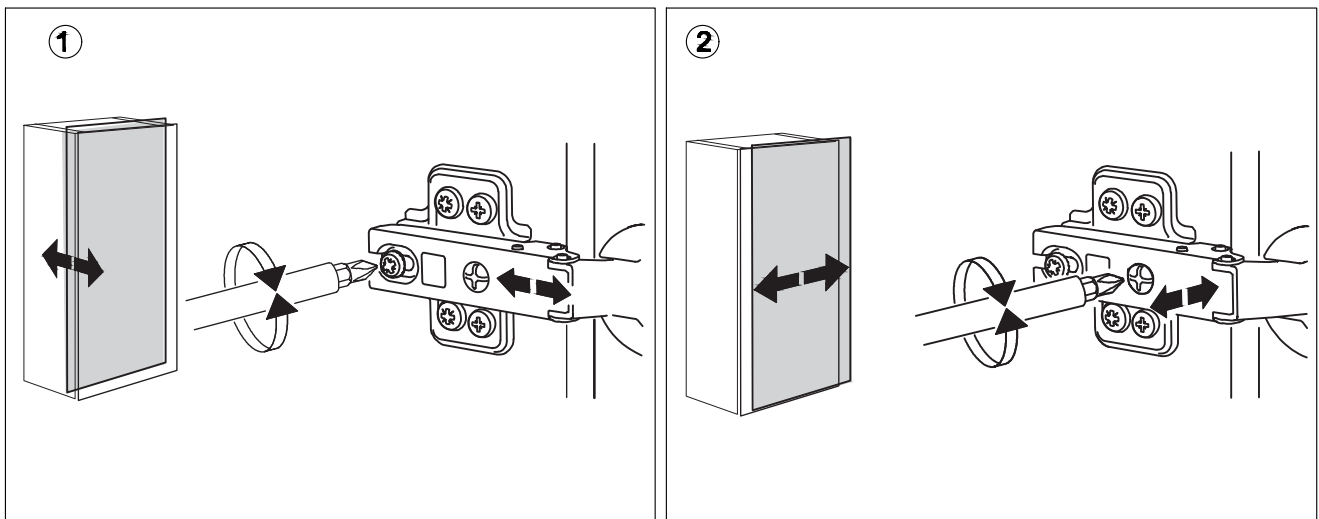

TIPS FOR ADJUSTMENT:

These "adjustments" are not preset and will need to be checked to meet the desired look

- We recommend the use of a #2 Phillips Screwdriver.
- Adjust in small steps and check your progress frequently.
- Use a measuring tape to ensure the gaps between the top and bottom of the door are even.
- Avoid forcing the door closed if it does not align properly, as this may damage the door.
- If the alignment is still off, make further adjustments as needed.

By following these steps, you can achieve a balanced door alignment.

If you need further adjustments, repeat the process in small increments.

Important notes:

While adjusting the hinges, firmly hold the door in place to prevent it from falling and getting damaged.

Repeatedly tightening and loosening the hinge screws can cause the screw holes to widen. To avoid this, minimize adjustments and avoid overtightening.



WARNING

For use with televisions weighing 176lb/ 80(Kg) or less.
Attention: this unit is not rated for use with a CRT type television.



WARNING

Death or serious injury may occur when children climb on audio and/or video equipment furniture. A remote control or toys placed on the furnishing may encourage a child to climb on the furnishing and as a result the furnishing may tip over on to the child.



WARNING

Relocating audio and/or video equipment to furniture not specifically designed to support audio and/or video equipment may result in death or serious injury due to the furnishing collapsing or over turning onto a child.

All other support shelves should not be loaded more than 25 lbs.

DO NOT EXCEED RECOMMENDED LOAD. Use with heavier televisions may result in instability causing tip over resulting in death or serious injury.

Please use caution when using electrical equipment. Improper use could result in the risk of fire, electric shock or injury to persons associated with the use of this unit during operation, user-maintenance, loading, storage, and, as applicable, electrical issues including grounding or double-insulation.

Electronic components generate heat that may cause damage to the equipment. Please refer to the manufacturer's owner's manual for space and ventilation requirements.

Do not allow children under 16 years to move cart.

