

HAPPINESS HAPPINESS INSTALLATION



CAUTION

Parts are placed at the bottom of the product.

- If you have any questions with the product, please contact us by:
- **Email: customerservice@zoy-living.com**
(we will reply to you within 24 hours)

Assembly Instructions

RR0302CF

Your loveseat and sofa comes in three kinds of packages. Carefully remove all of components from the packaging and set aside for assembly.

CAUTION

DO NOT use any sharp objects to open plastic-wrapped components as this may result in damage to the product or components.
Please select your installation method based on your actual purchasing needs.

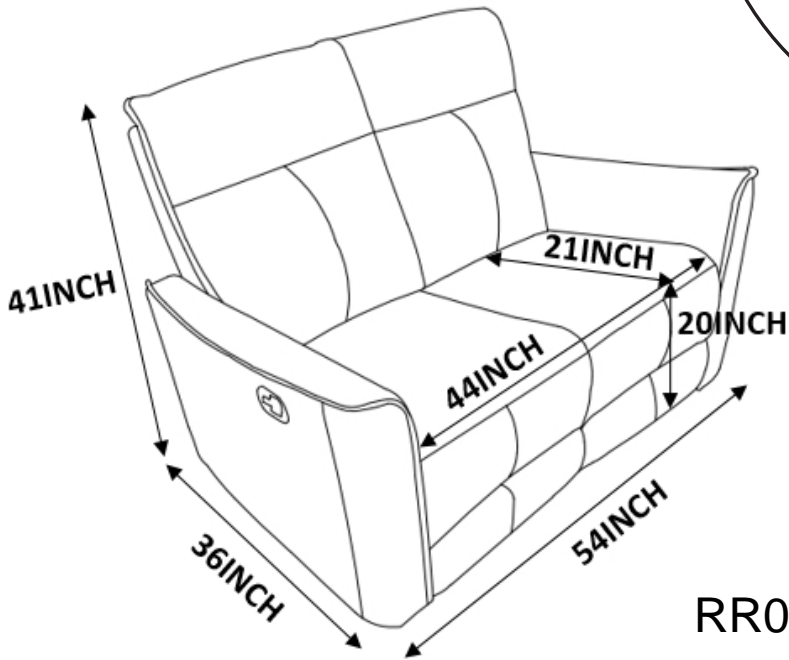



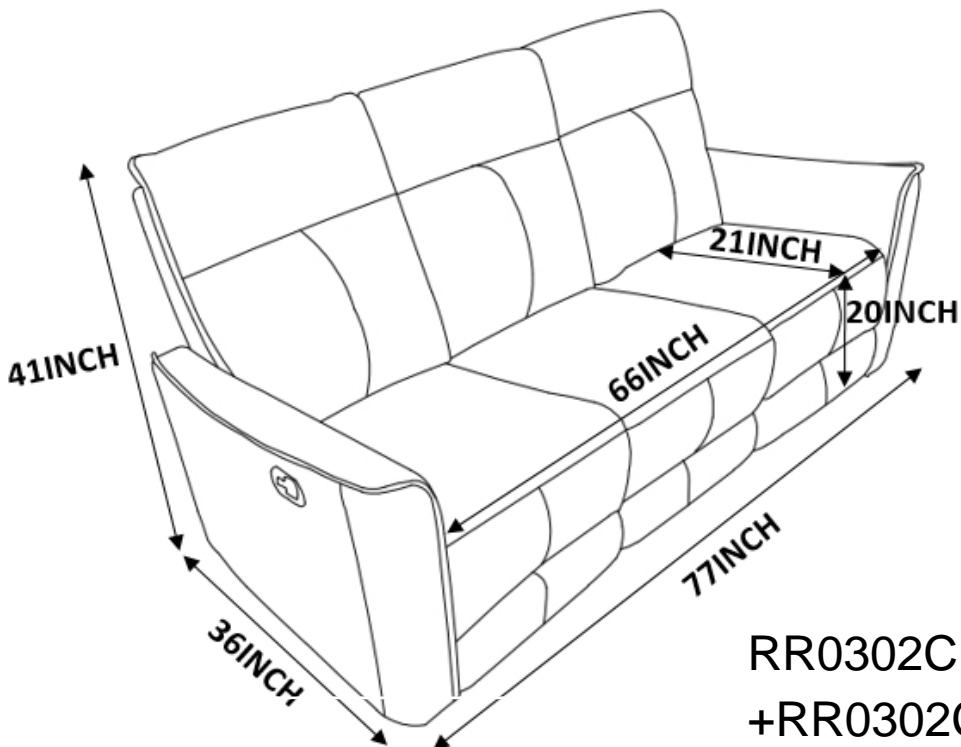

RR0302CF51L+RR0302CF51R

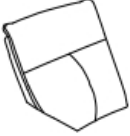
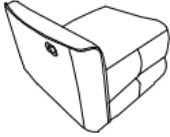

RR0302CF51L+RS0302CF61N
+RR0302CF51R

Package Contents

				BOX RR0302CF51L
A*1	C*1			
				BOX RS0302CF61N
E*1	F*1			
				BOX RR0302CF51R
B*1	D*1			

STEP1:

Assemble the **Back(A&B&E)** to its **Seat(C&D&F)**, making sure it is securely installed before use. Next Connect the parts of the loveseat and sofa assembly by means of the metal clips at the bottom.

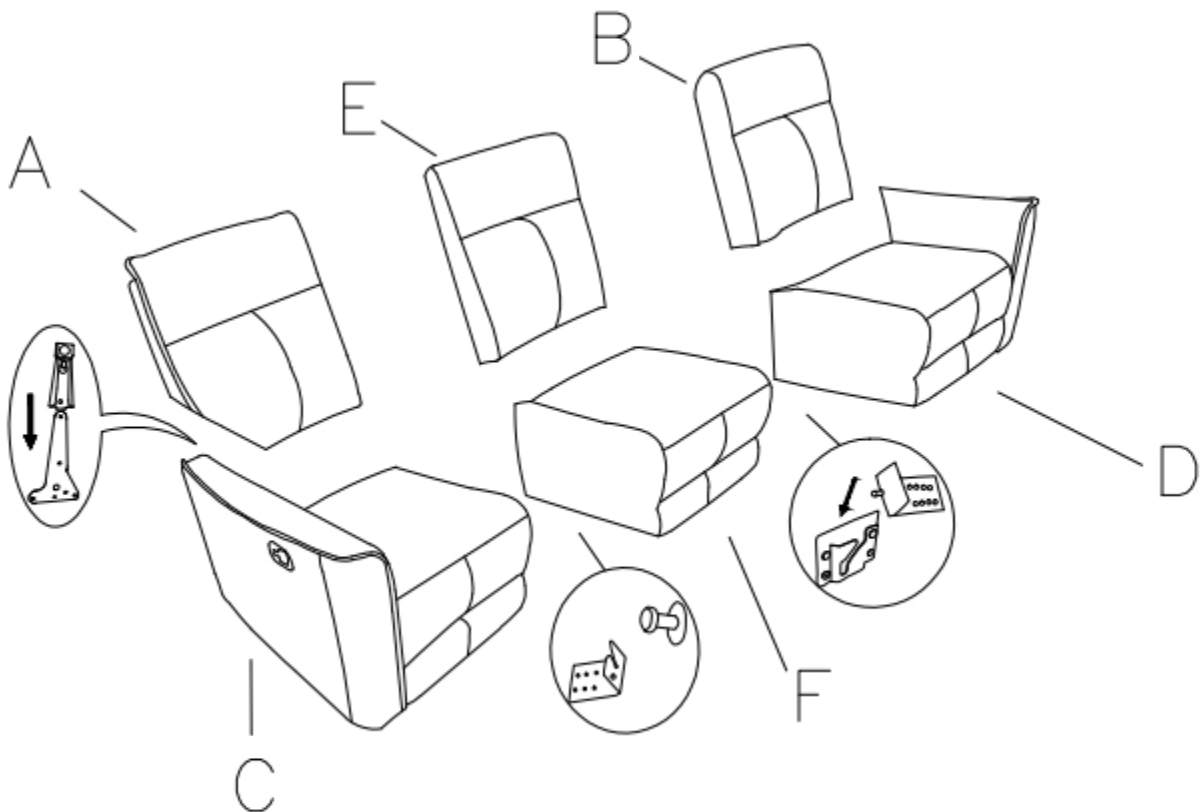
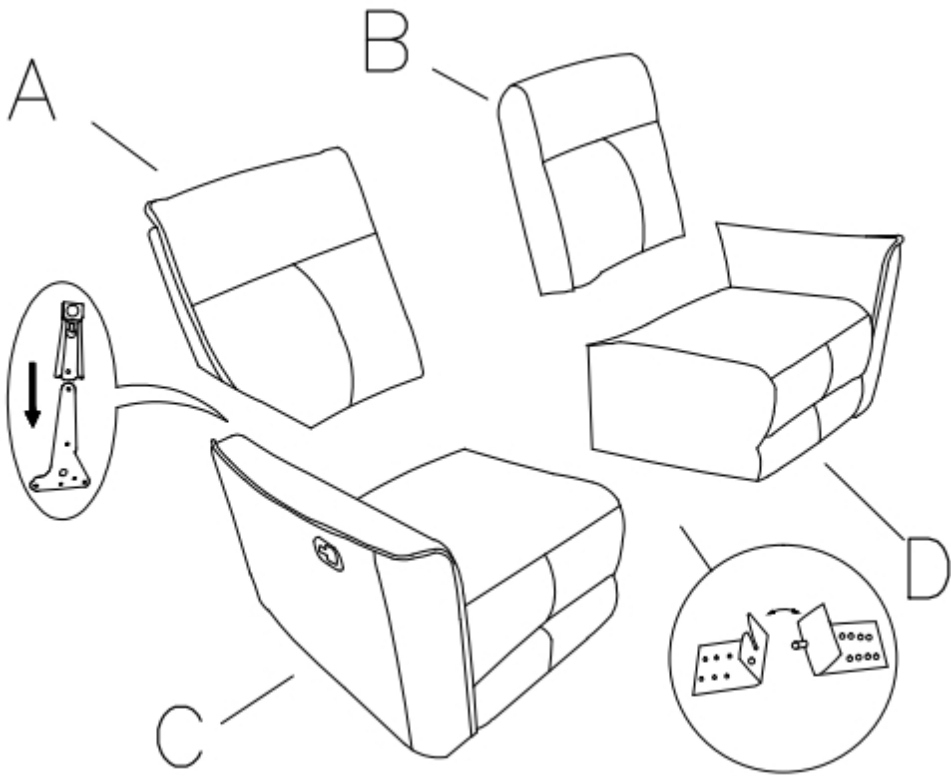

ASSEMBLY COMPLETED

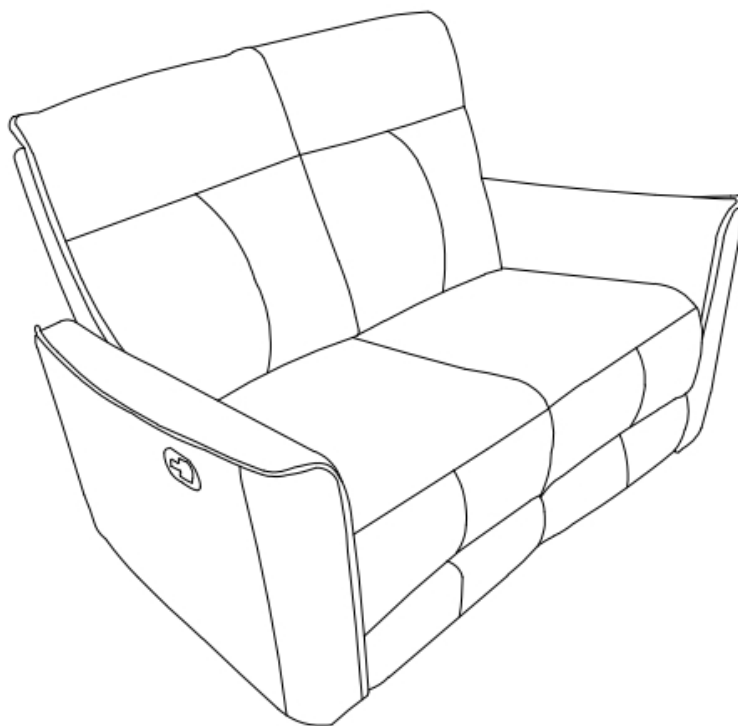

Loveseat

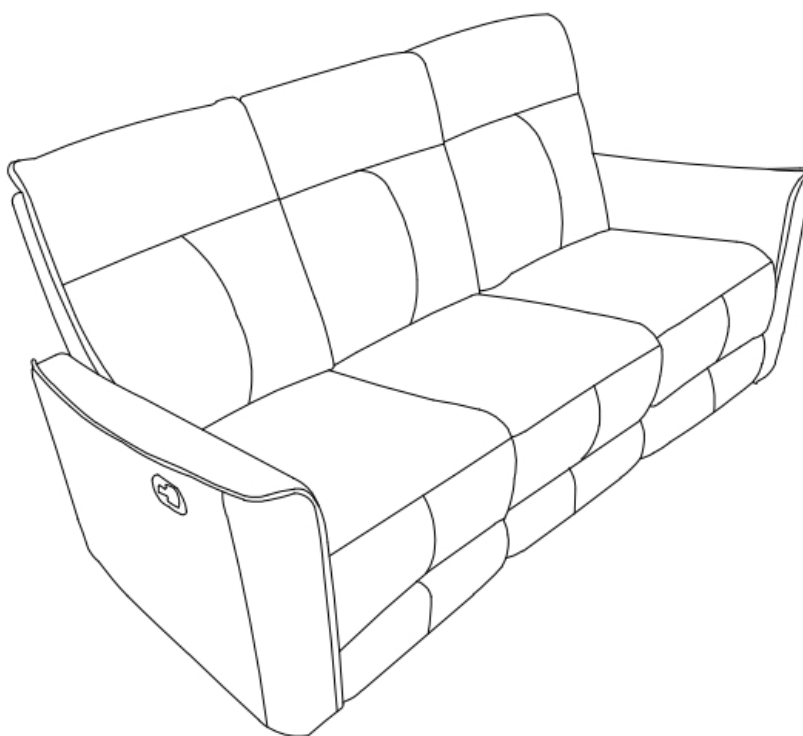

Sofa

Warnings

1. Please check if the components of the chair are all included and can be used normally.
2. Assemble all components according to the instruction correctly before you connect the chair to the power.
3. Please DO NOT sit on the armrests or footrest to eliminate the risk of tipping over.
4. If the chair is damaged or doesn't match the website description, please send clear pictures of the product and label of the carton to our service team for further help.
5. If the recliner doesn't work, you may try the following measures for self-checking firstly:
 - a) Check if all the cables are connected;
 - b) Check if the light of transformer is on.

If the chair still doesn't work, please feed the information back to our customer service in time and we'll help you solve the matter as soon as possible.

6. If you have any questions with the product, please contact us by:

Email: customerservice@zoy-living.com (we will reply to you within 24 hours)

