

Transforming houses into homes (English & Español)

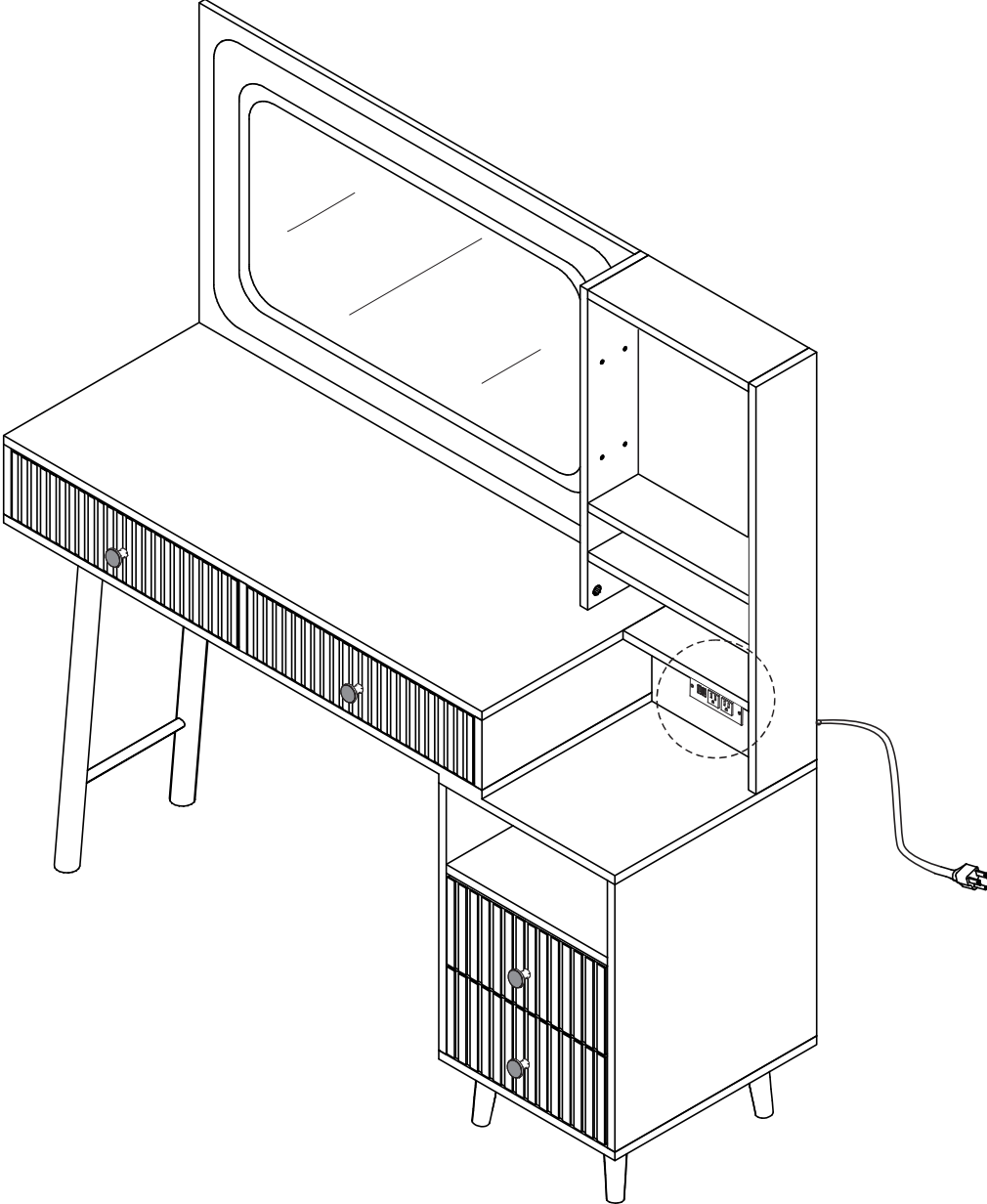

# INSTRUCTION MANUAL

If you have any problems, please send your order number and photos to us.  
We will contact you within 24 hours and provide you with a satisfactory solution.

---

**! NOTICE** Please retain these instructions for future reference.

- Carefully unpack all the components and verify that all the necessary parts are included as listed in the packaging.
- Identify each component and refer to the provided assembly diagram or step-by-step instructions.
- Assemble the furniture in the order specified to ensure proper alignment and fit.
- Use the provided tools or recommended tools for assembly. Do not use excessive force when tightening screws or bolts.
- If any difficulties arise during assembly. Consult the troubleshooting section or contact our customer support.

# ASSEMBLY INSTRUCTIONS

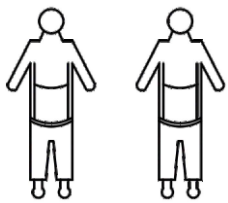
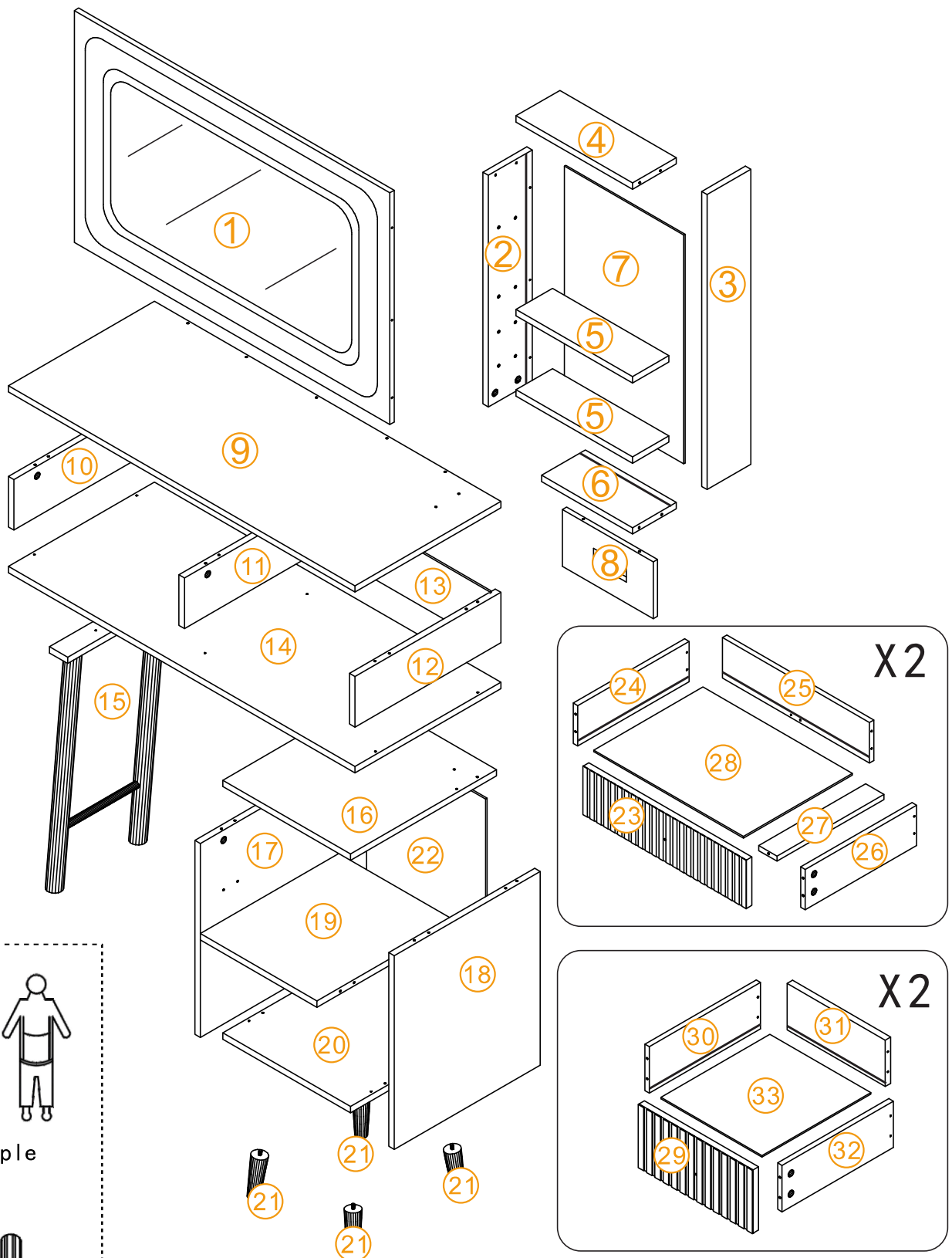

2 people

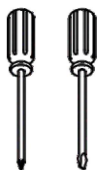









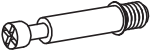



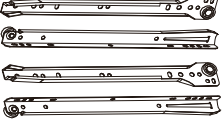

Phillips Screwdriver

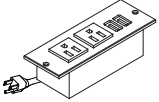
# ☰ PARTS LIST

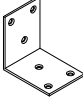
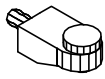
- |   |  |  |   |   |   |
|---|--|--|---|---|---|
| <b>01</b><br>Mirror Surface<br><br>1 PC       | <b>02</b><br>Left Side Panel<br><br>1 PC            | <b>03</b><br>Right Side Panel<br><br>1 PC       | <b>04</b><br>Top Panel<br><br>1 PC              | <b>05</b><br>Adjustable Shelf<br><br>2 PCS     | <b>06</b><br>Top Panel<br><br>1 PC                 |
| <b>07</b><br>Thin Back Panel<br><br>1 PC      | <b>08</b><br>Small Back Panel<br><br>1 PC           | <b>09</b><br>Tabletop Panel<br><br>1 PC         | <b>10</b><br>Left Side Panel<br><br>1 PC        | <b>11</b><br>Middle Side Panel<br><br>1 PC     | <b>12</b><br>Right Side Panel<br><br>1 PC          |
| <b>13</b><br>Thin Back Panel<br><br>1 PC      | <b>14</b><br>Bottom Panel<br><br>1 PC               | <b>15</b><br>Table Leg<br><br>1 PC              | <b>16</b><br>Top Panel<br><br>1 PC              | <b>17</b><br>Left Side Panel<br><br>1 PC       | <b>18</b><br>Right Side Panel<br><br>1 PC          |
| <b>19</b><br>Shelf<br><br>1 PC              | <b>20</b><br>Bottom Panel<br><br>1 PC             | <b>21</b><br>Table Leg<br><br>4 PCS           | <b>22</b><br>Thin Back Panel<br><br>1 PC      | <b>23</b><br>Drawer Front Panel<br><br>2 PCS | <b>24</b><br>Drawer Left Side Panel<br><br>2 PCS |
| <b>25</b><br>Drawer Back Panel<br><br>2 PCS | <b>26</b><br>Drawer Right Side Panel<br><br>2 PCS | <b>27</b><br>Drawer Pull Strip<br><br>2 PCS   | <b>28</b><br>Drawer Bottom Panel<br><br>2 PCS | <b>29</b><br>Drawer Front Panel<br><br>2 PCS | <b>30</b><br>Drawer Left Side Panel<br><br>2 PCS |
| <b>31</b><br>Drawer Back Panel<br><br>2 PCS | <b>32</b><br>Drawer Right Side Panel<br><br>2 PCS | <b>33</b><br>Drawer Bottom Panel<br><br>2 PCS |   |   |   |

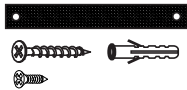
# ☰ HARDWARE LIST

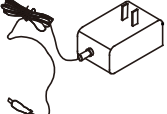
<p><b>A</b></p> <p>M6x35mm Cam Bolt</p>  <p>X 49+2</p>	<p><b>B</b></p> <p>M15x10mm Cam Lock</p>  <p>X 49+2</p>	<p><b>C</b></p> <p>M6x30mm Dowel</p>  <p>X 20+2</p>	<p><b>D</b></p> <p>M5x40mm Screw</p>  <p>X 33+2</p>
<p><b>E</b></p> <p>Drawer Slides</p>  <p>CR DR CL DL</p> <p>X 4</p>	<p><b>F</b></p> <p>M3.5x12mm Screw</p>  <p>X 32+2</p>	<p><b>G</b></p> <p>Hold Hands</p>  <p>X 4</p>	<p><b>H</b></p> <p>M4x18mm Handle Bolt</p>  <p>X 4</p>
<p><b>J</b></p> <p>Power Socket</p>  <p>X 1</p>	<p><b>K</b></p> <p>M3.5x14mm Screw</p>  <p>X 26+2</p>	<p><b>L</b></p> <p>Fixed Iron</p>  <p>X 2</p>	<p><b>M</b></p> <p>Adjustable Shelf Bracket</p>  <p>X 8+1</p>
<p><b>N</b></p> <p>M6x30mm Screw</p>  <p>X 3</p>	<p><b>O</b></p> <p>Allen key</p>  <p>X 1</p>	<p><b>P</b></p> <p>Anti-tipping Device</p>  <p>X 2</p>	<p><b>Q</b></p> <p>Hole Patch</p>  <p>X 33+2</p>
<p><b>R</b></p> <p>Backboard buckle</p>  <p>X 12+1</p>	<p><b>S</b></p> <p>External power supply</p>  <p>X 1</p>		



If you are missing any parts, please provide your order number and circle the part number. Send us a photo of this, and we will provide you with a satisfactory solution. Thank you.

# STEP 1

Please tighten the screws after completing all installation

Porfavor, apriete lostornillos despuesde instalar to do

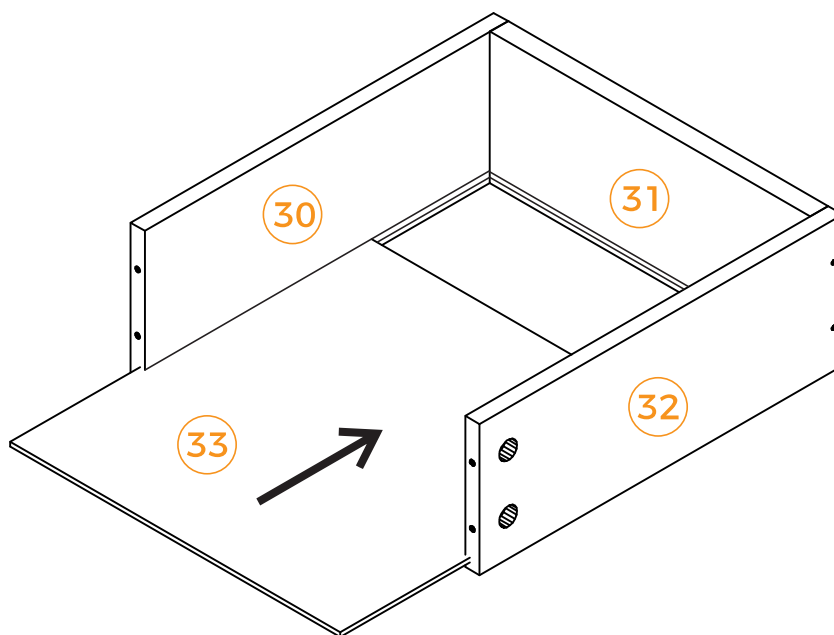
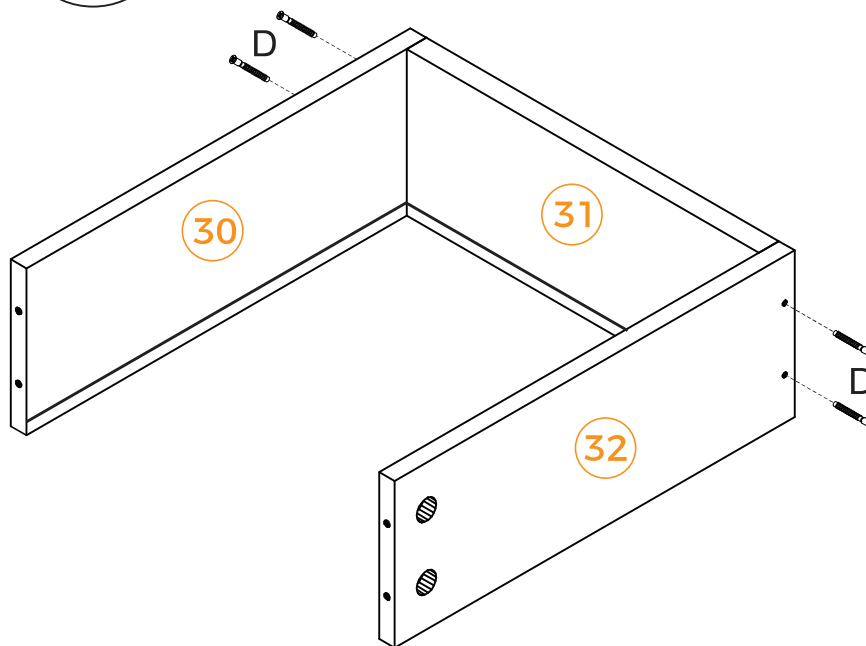
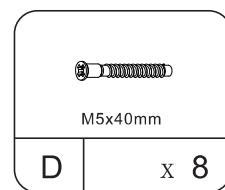
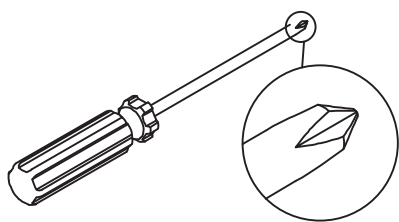



# STEP 2

Please tighten the screws after completing all installation

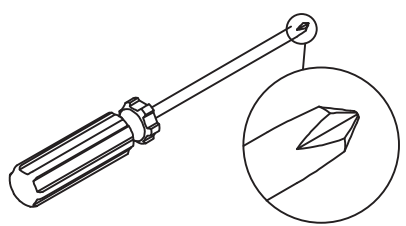
Porfavor, apriete lostornillos despuesde instalar to do

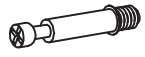

	
M6x35mm	
A	x 8

	
M15x10mm	
B	x 8

	
Hold Hands	
G	x 2

	
M4x18mm	
H	x 2

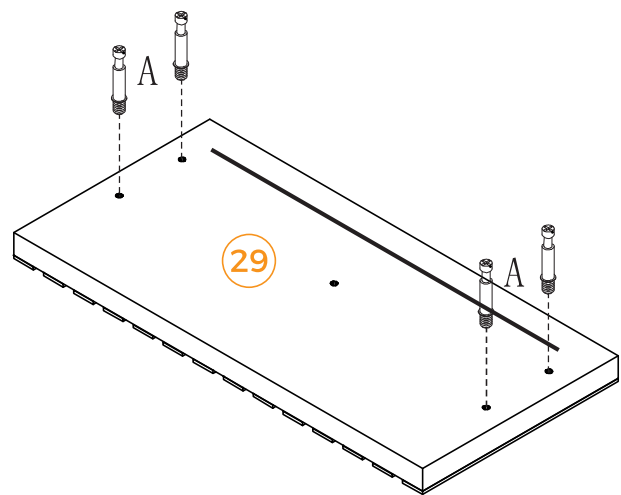
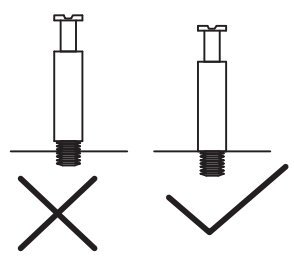

X 2

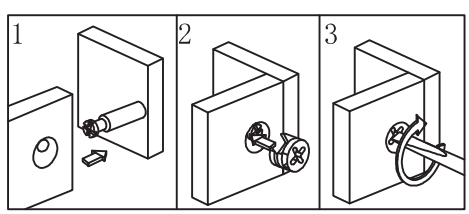
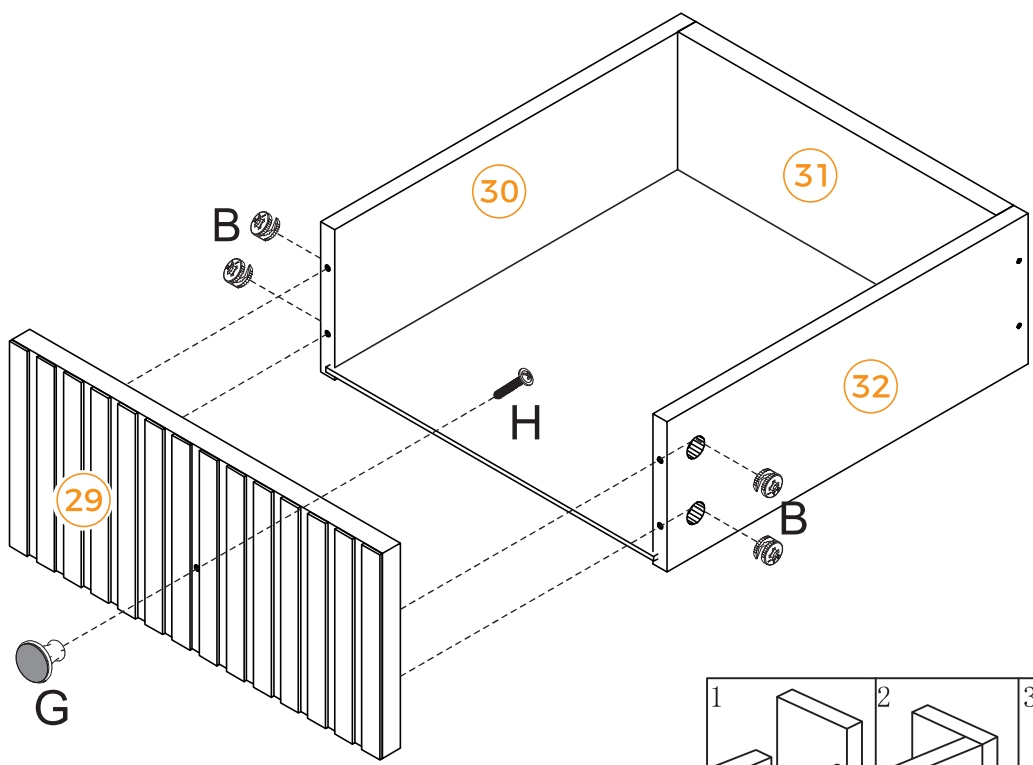



# STEP 3

Please tighten the screws after completing all installation

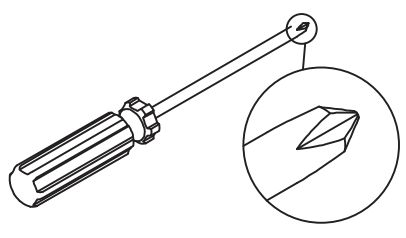
Porfavor, apriete lostornillos despuesde instalar to do



 DR	
 DL	
E	X 2

 M3.5x12mm	
F	X 8

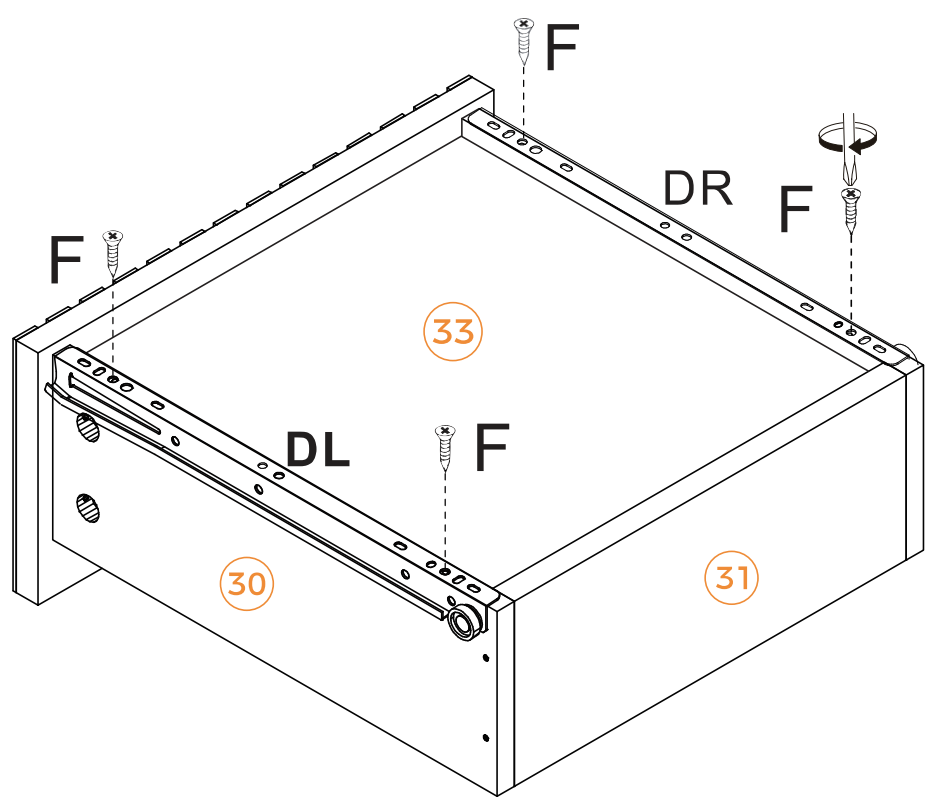
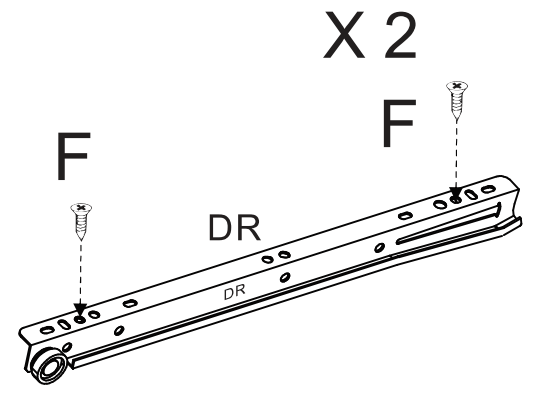
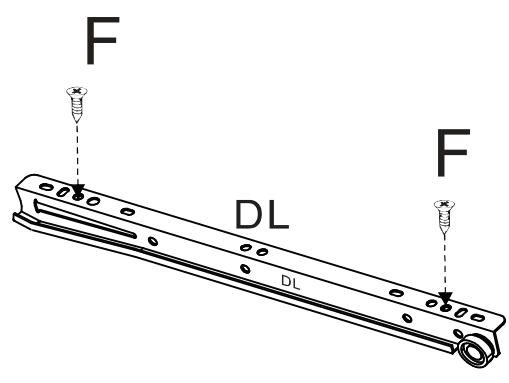

# STEP 4

Please tighten the screws after completing all installation

Porfavor, apriete lostornillos despuesde instalar to do

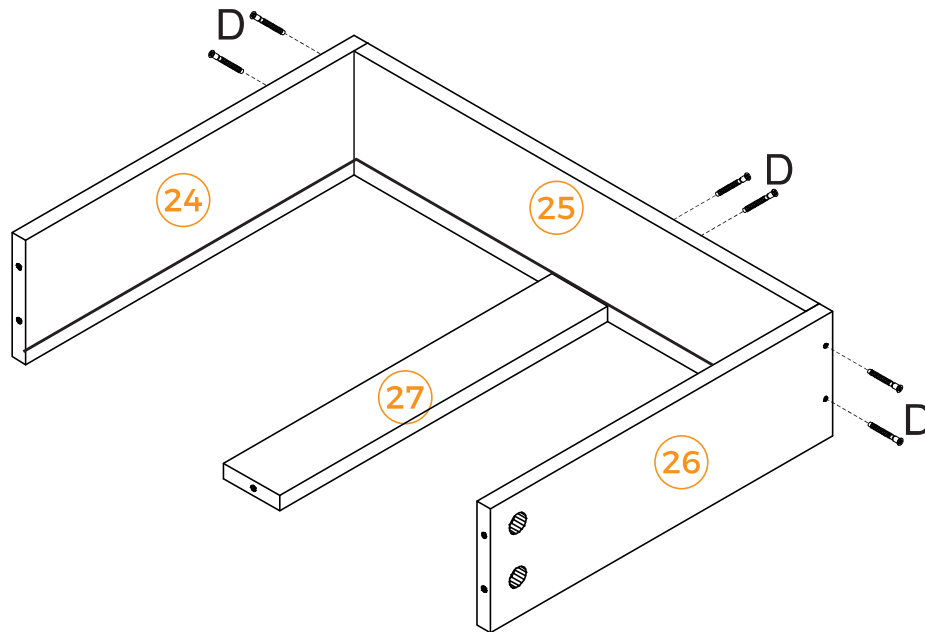
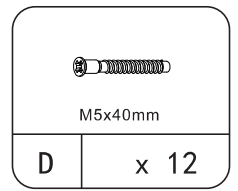
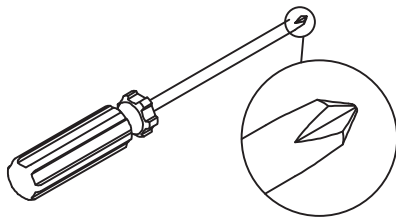

X 2

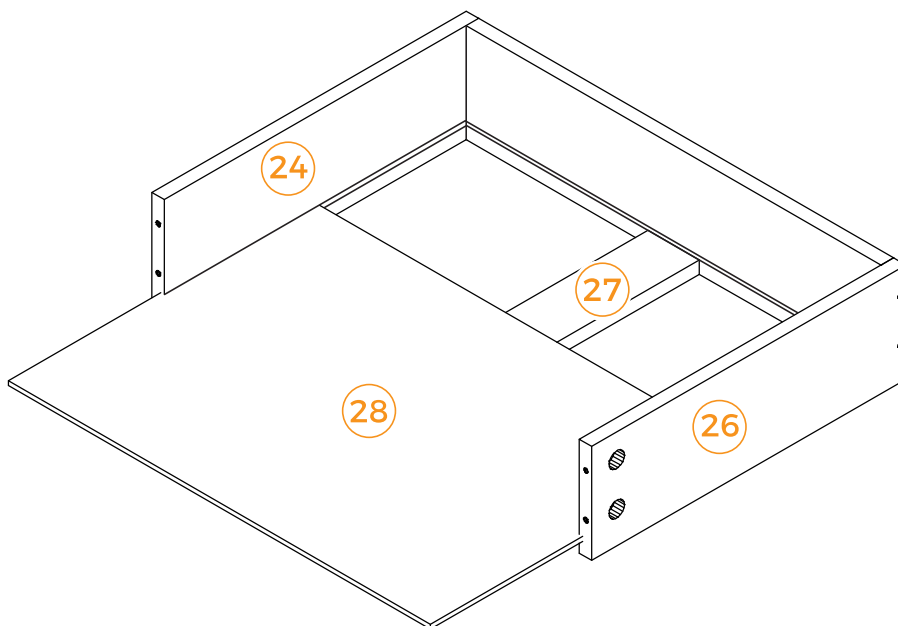

X 2

# STEP 5

Please tighten the screws after completing all installation

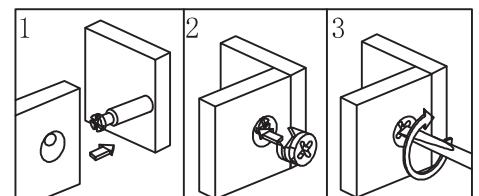
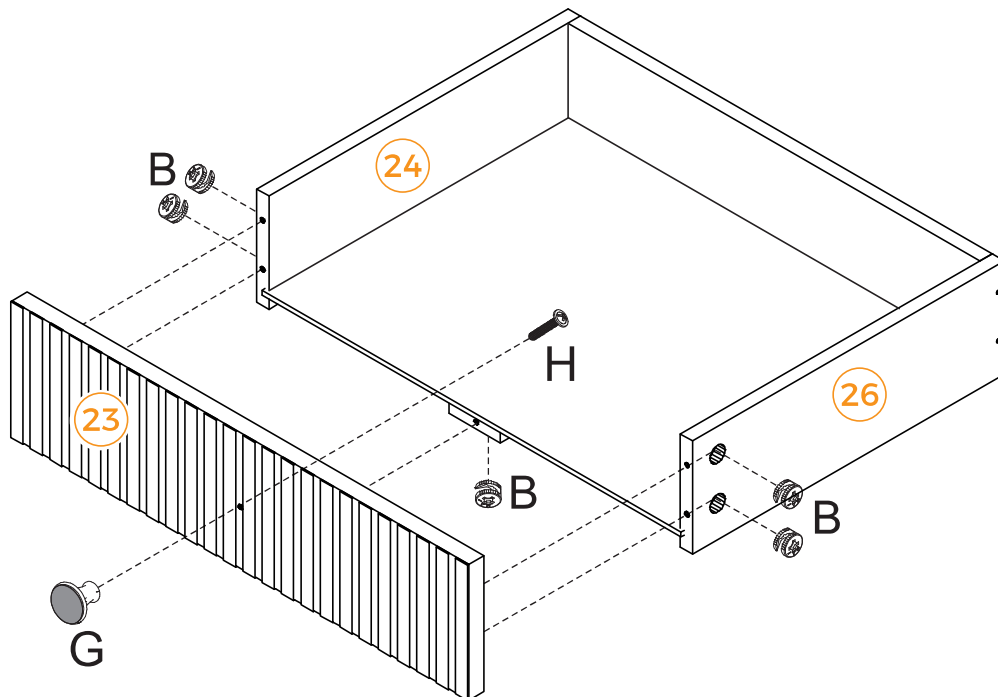
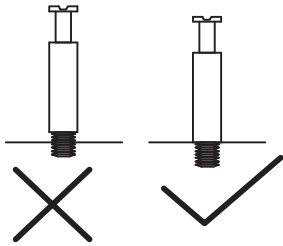
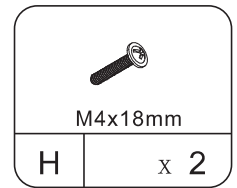
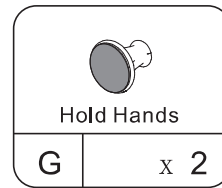
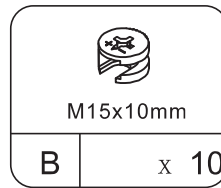
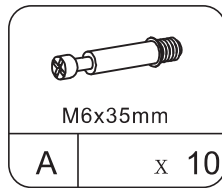
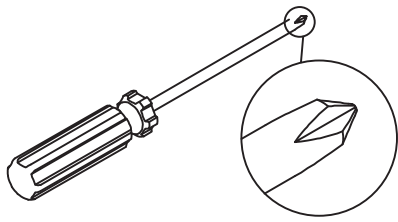

Porfavor, apriete lostornillos despuesde instalar to do



# STEP 6

Please tighten the screws after completing all installation

Porfavor, apriete lostornillos despuesde instalar to do

		DR
		DL
E	x 2	

		M3.5x12mm
F	x 8	

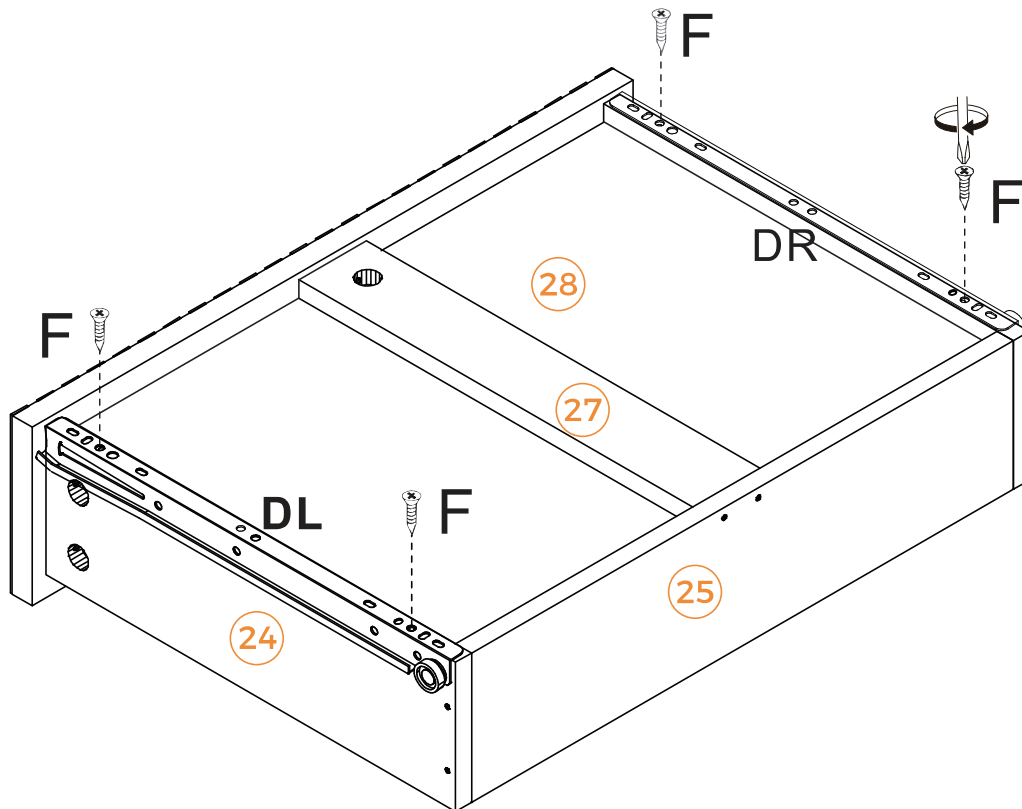
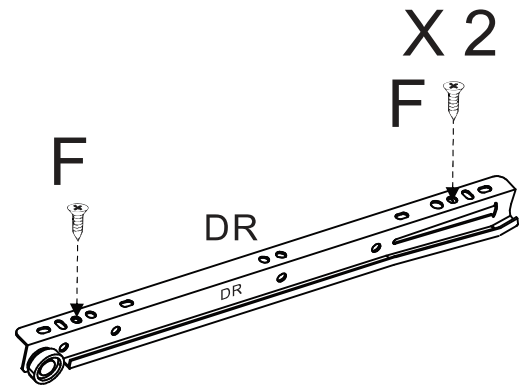
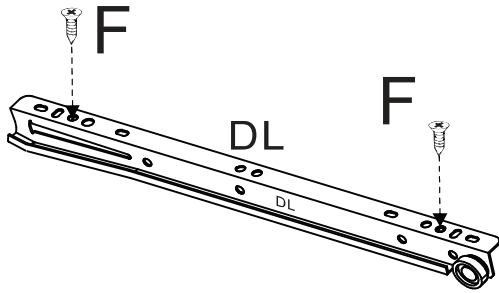
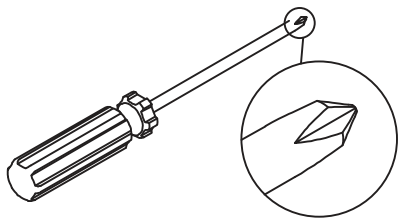

# STEP 7

Please tighten the screws after completing all installation

Porfavor, apriete lostornillos despuesde instalar to do

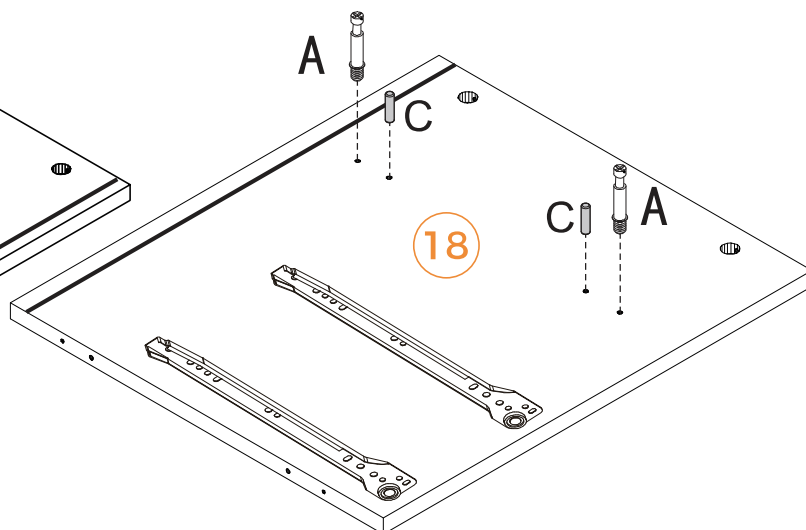
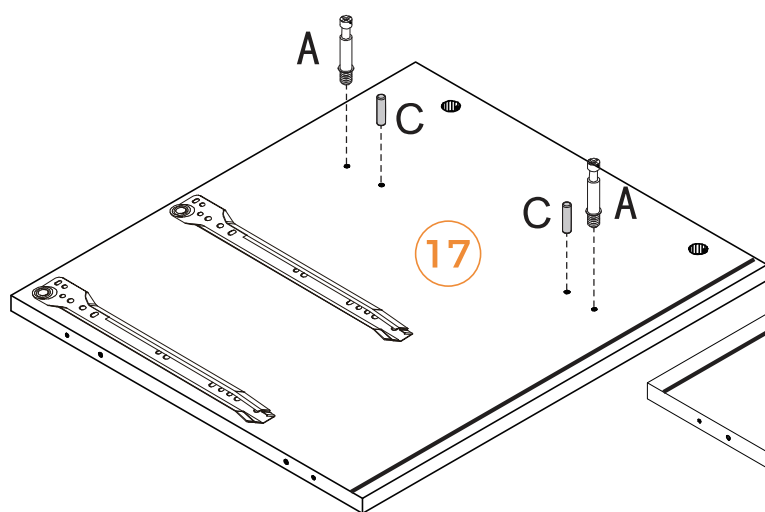
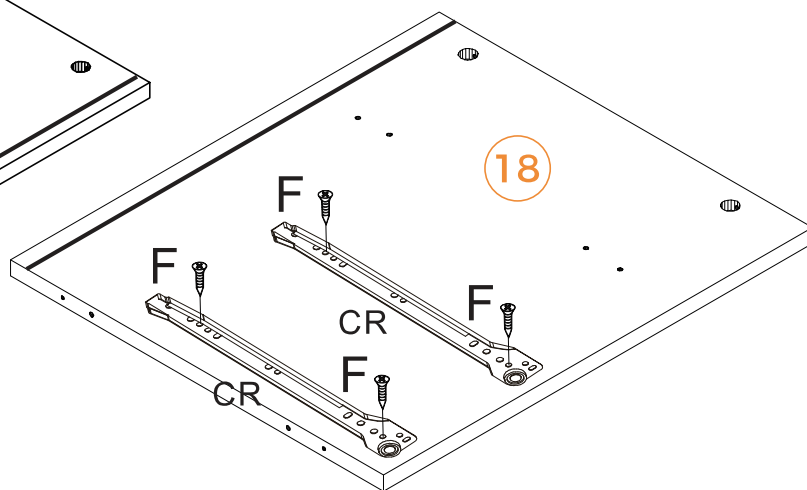
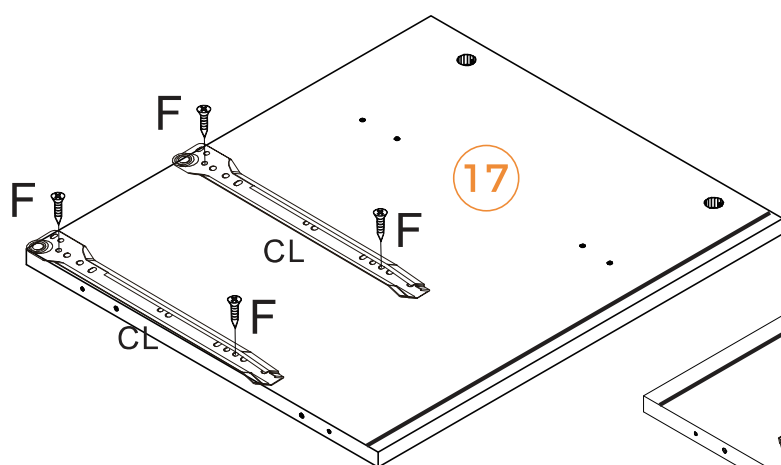
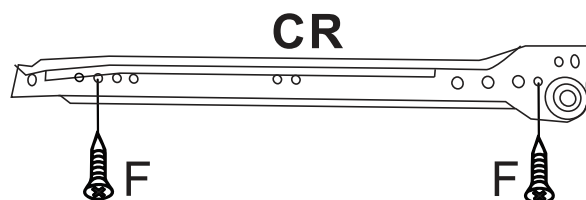
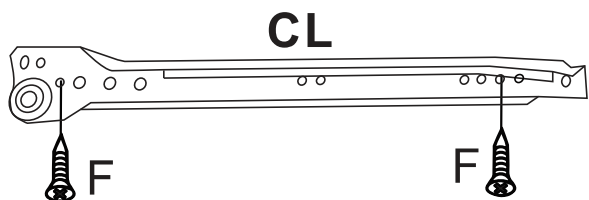
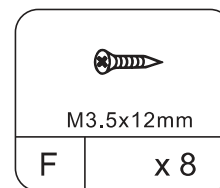
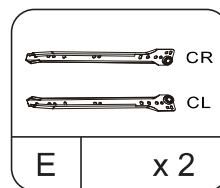
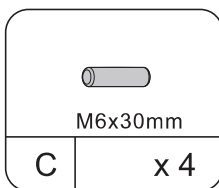
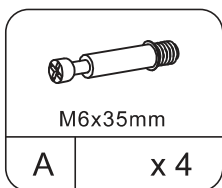
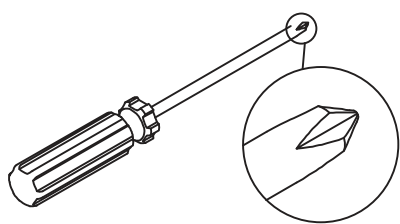

# STEP 8

Please tighten the screws after completing all installation

Porfavor, apriete lostornillos despuesde instalar to do

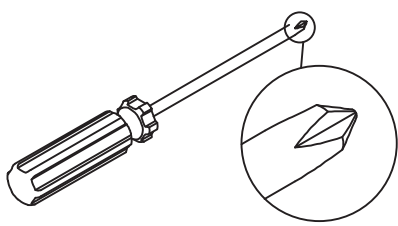

	
M15x10mm	
B	x 4

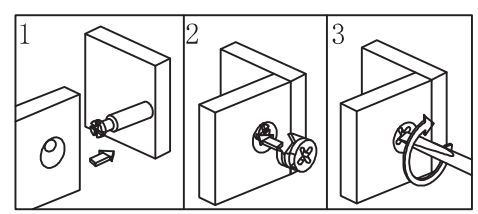
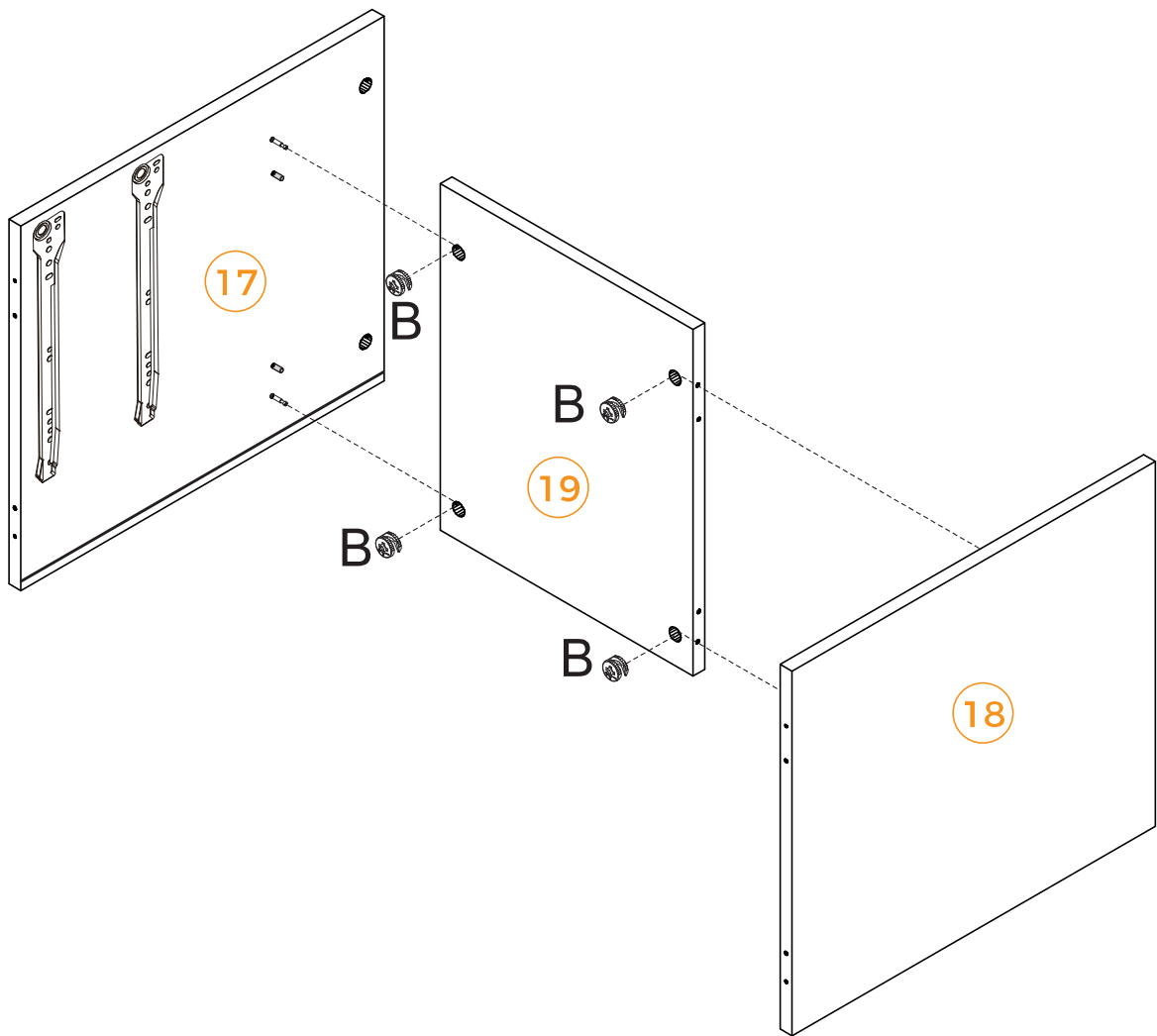



# STEP 9

Please tighten the screws after completing all installation

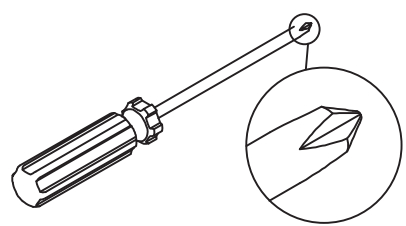
Porfavor, apriete lostornillos despuesde instalar to do



	
M6x30mm	
C	x 4

	
M5x40mm	
D	x 4

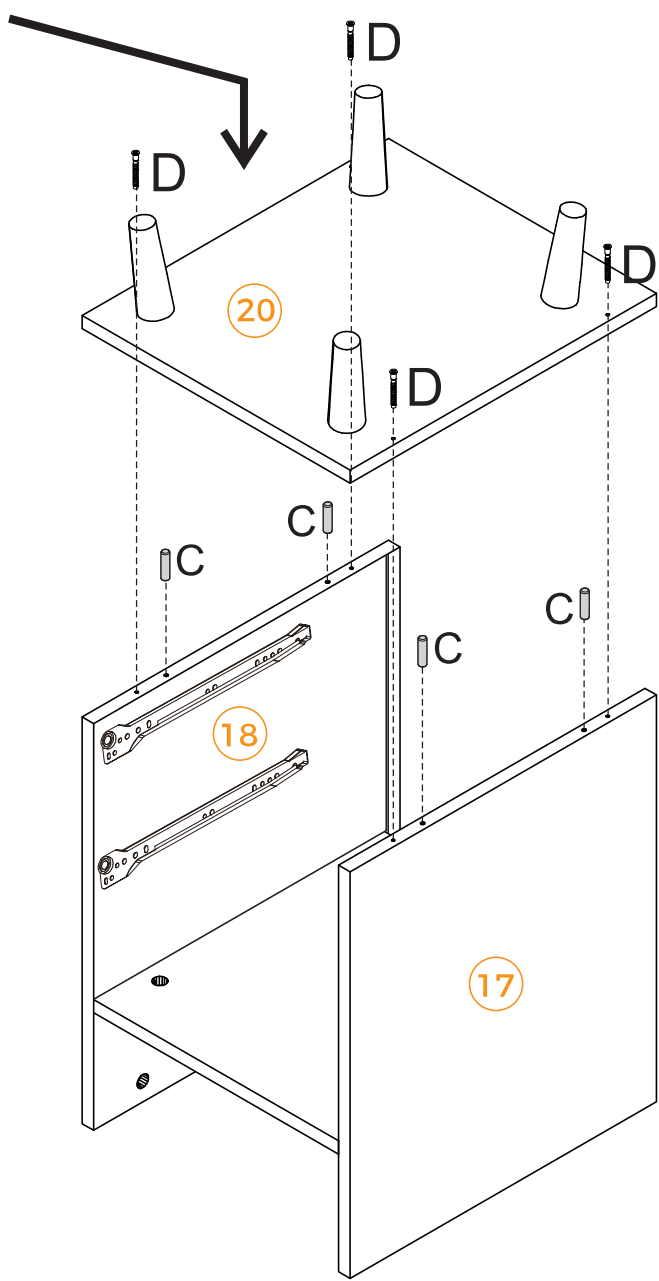
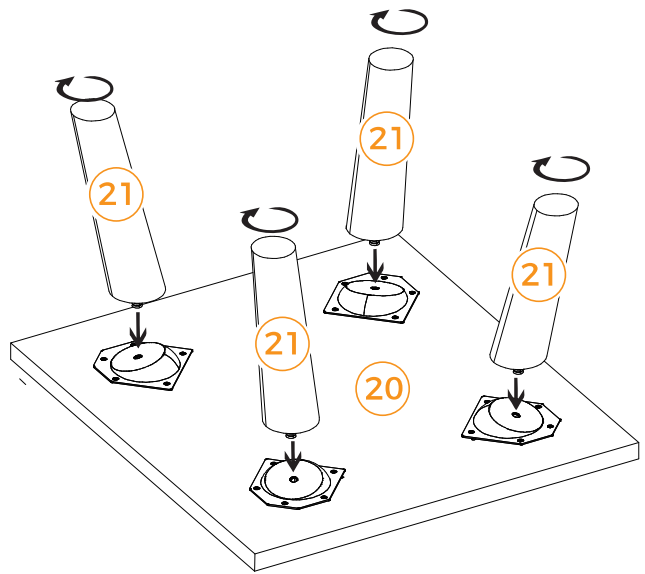

---

# STEP 10

Please tighten the screws after  
completing all installation

Porfavor, apriete lostornillos  
despuesde instalar to do

---

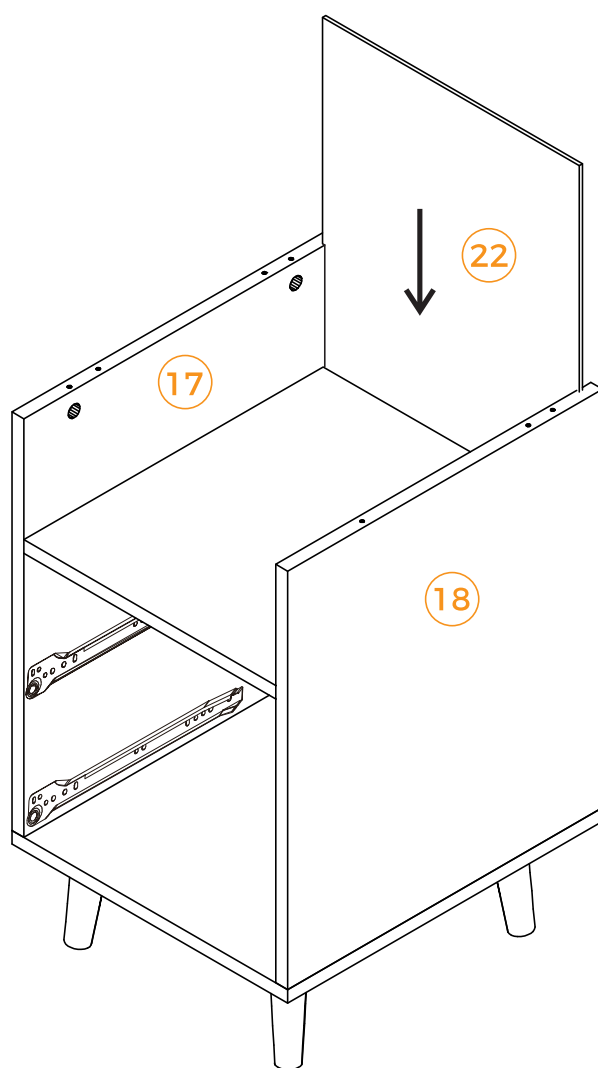



# STEP 11

Please tighten the screws after completing all installation

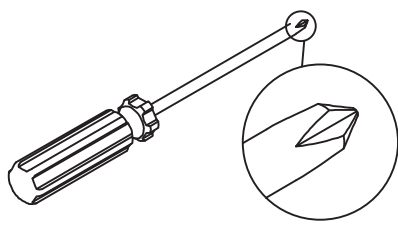
Porfavor, apriete lostornillos despuesde instalar to do

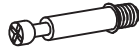

	
M6x35mm	
A	x 4

	
M15x10mm	
B	x 4

	
M6x30mm	
C	x 4

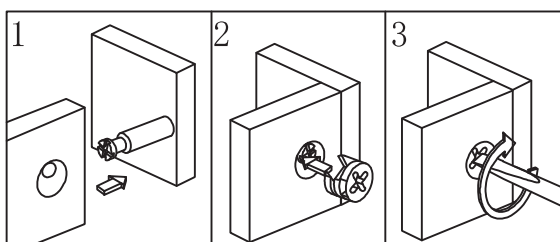
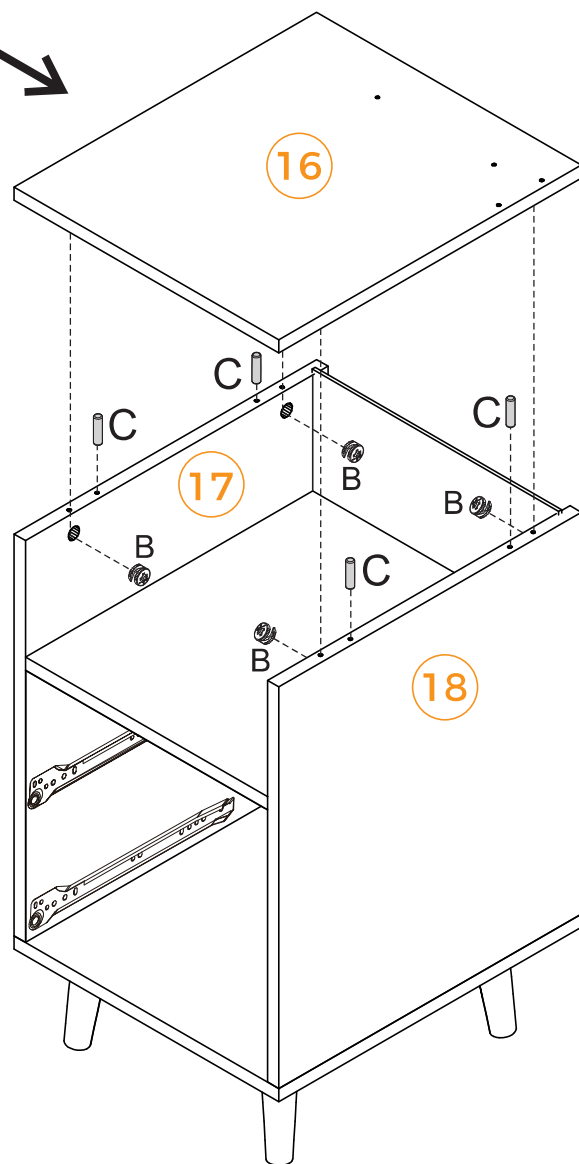
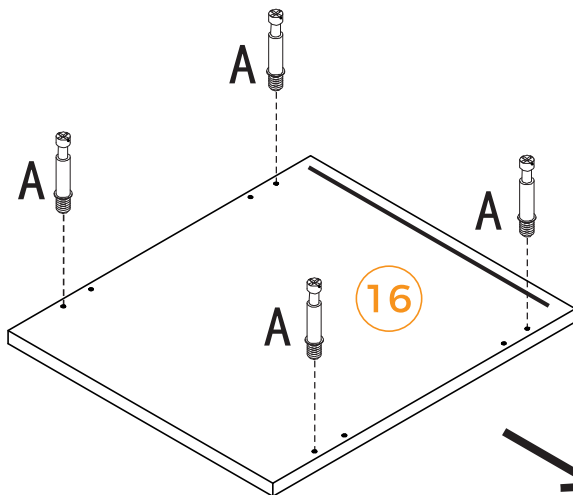



# STEP 12

Please tighten the screws after completing all installation

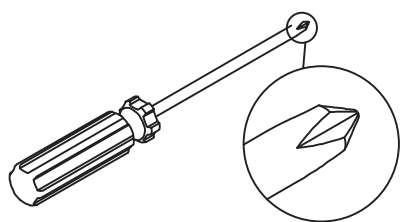
Porfavor, apriete lostornillos despuesde instalar to do



 CR		 M3.5x12mm	
 CL			
E	x 2	F	x 8

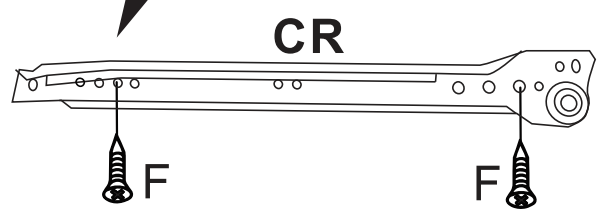
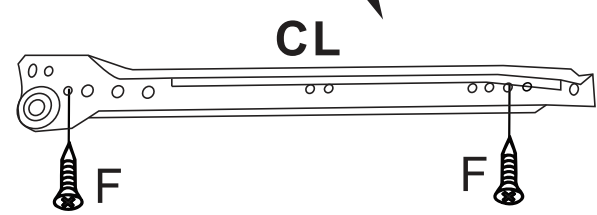
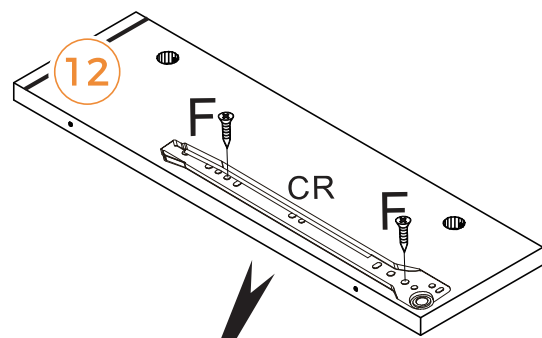
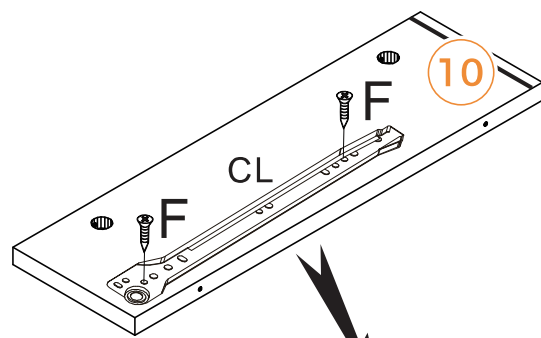
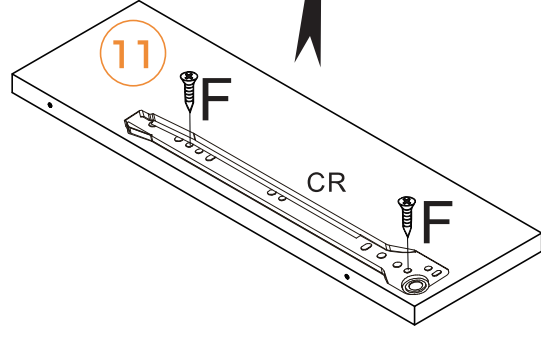
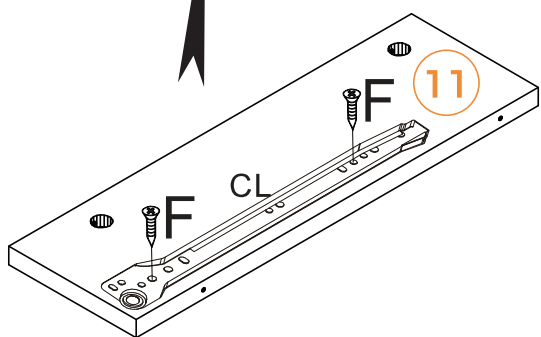
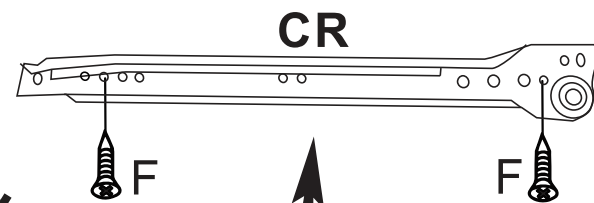
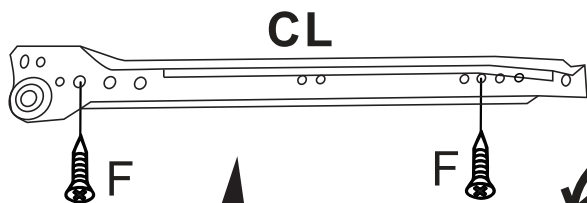

# STEP 13

Please tighten the screws after completing all installation

Porfavor, apriete lostornillos despuesde instalar to do

	
M5x40mm	
D	x 6

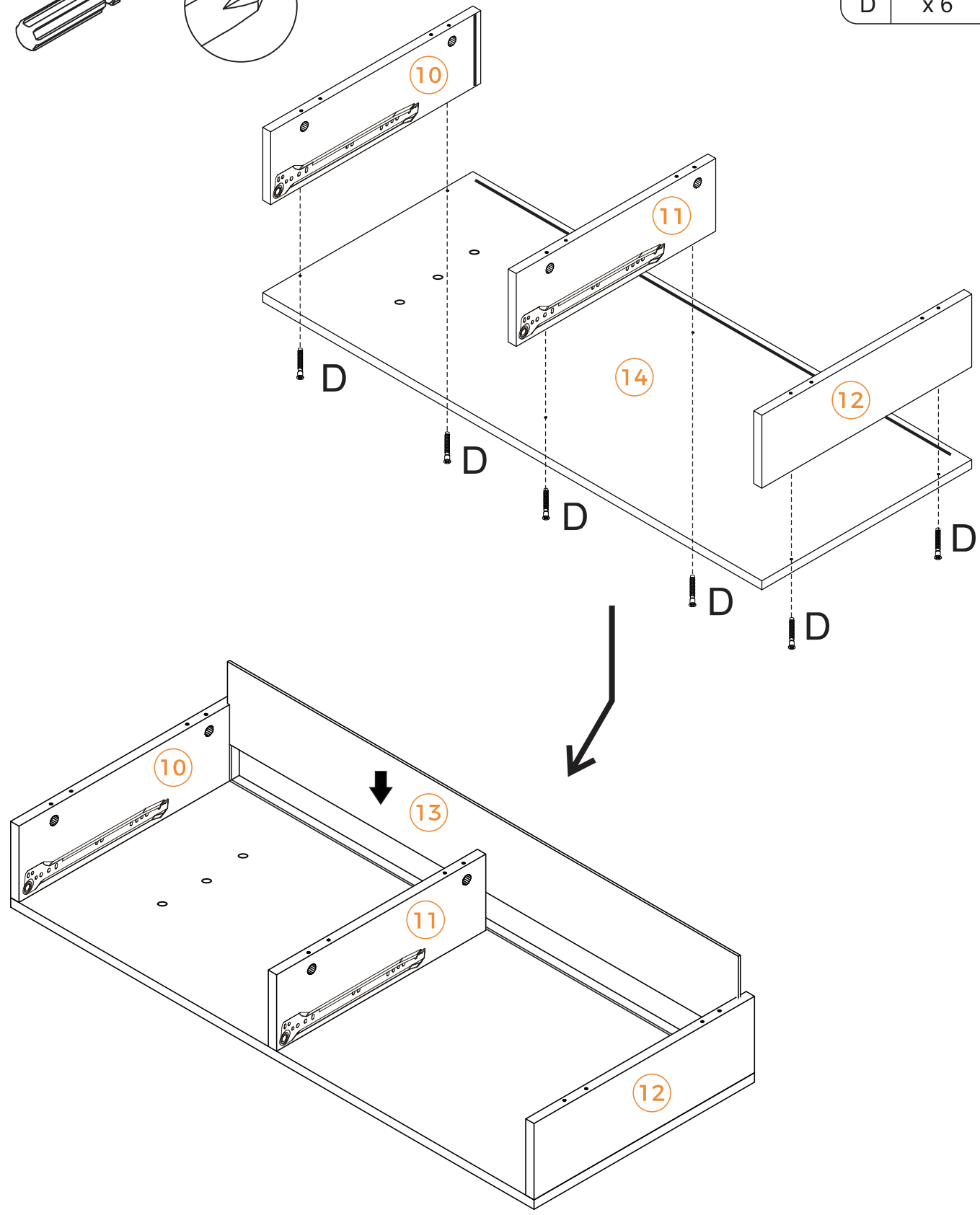
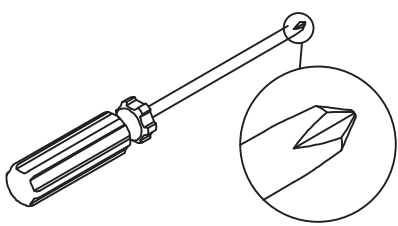

# STEP 14

Please tighten the screws after completing all installation

Porfavor, apriete lostornillos despuesde instalar to do

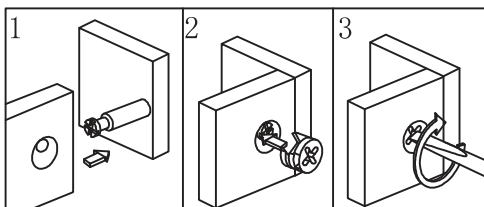
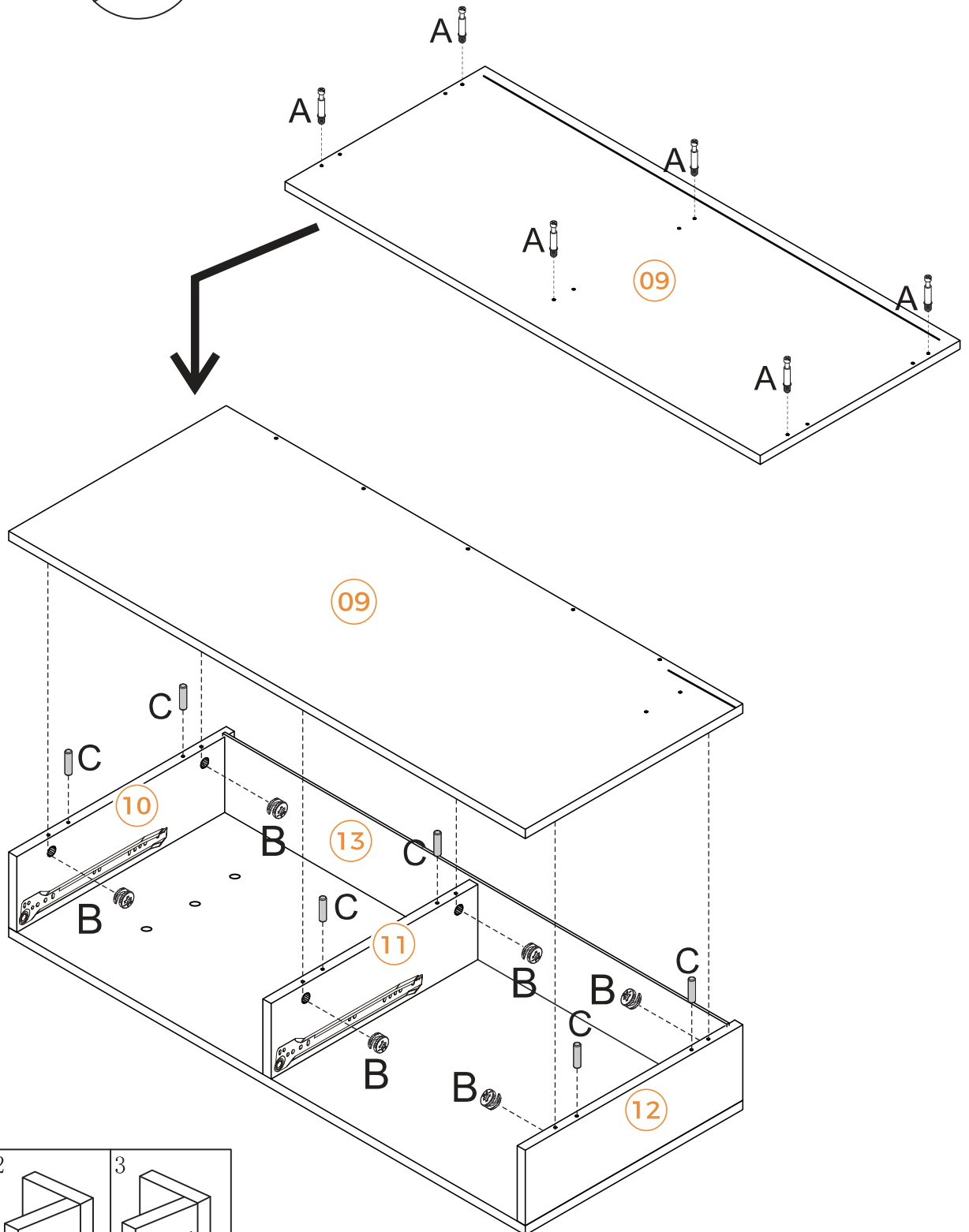
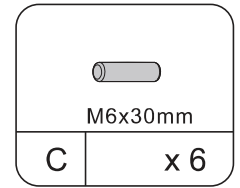
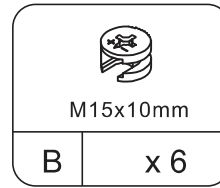
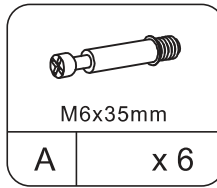
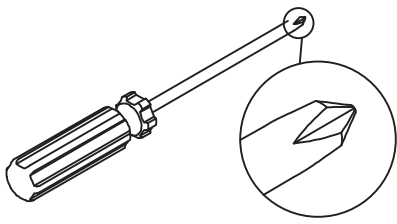

# STEP 15

Please tighten the screws after completing all installation

Porfavor, apriete lostornillos despuesde instalar to do

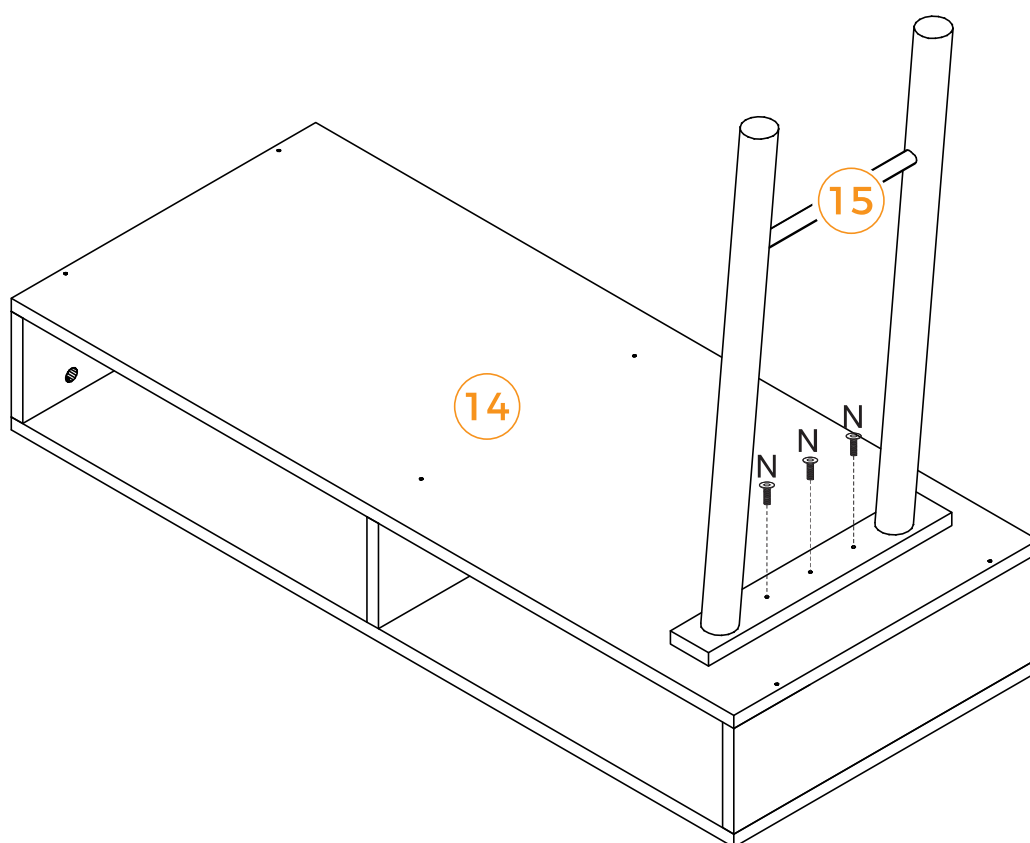
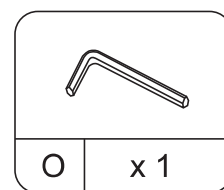
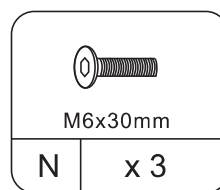



# STEP 16

Please tighten the screws after completing all installation

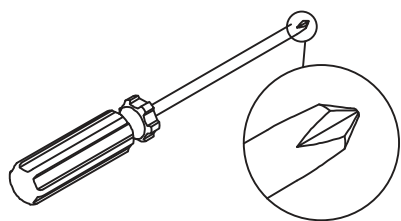
Porfavor, apriete lostornillos despuesde instalar to do

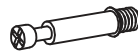

	
M6x35mm	
A	x 9

	
M6x30mm	
C	x 2

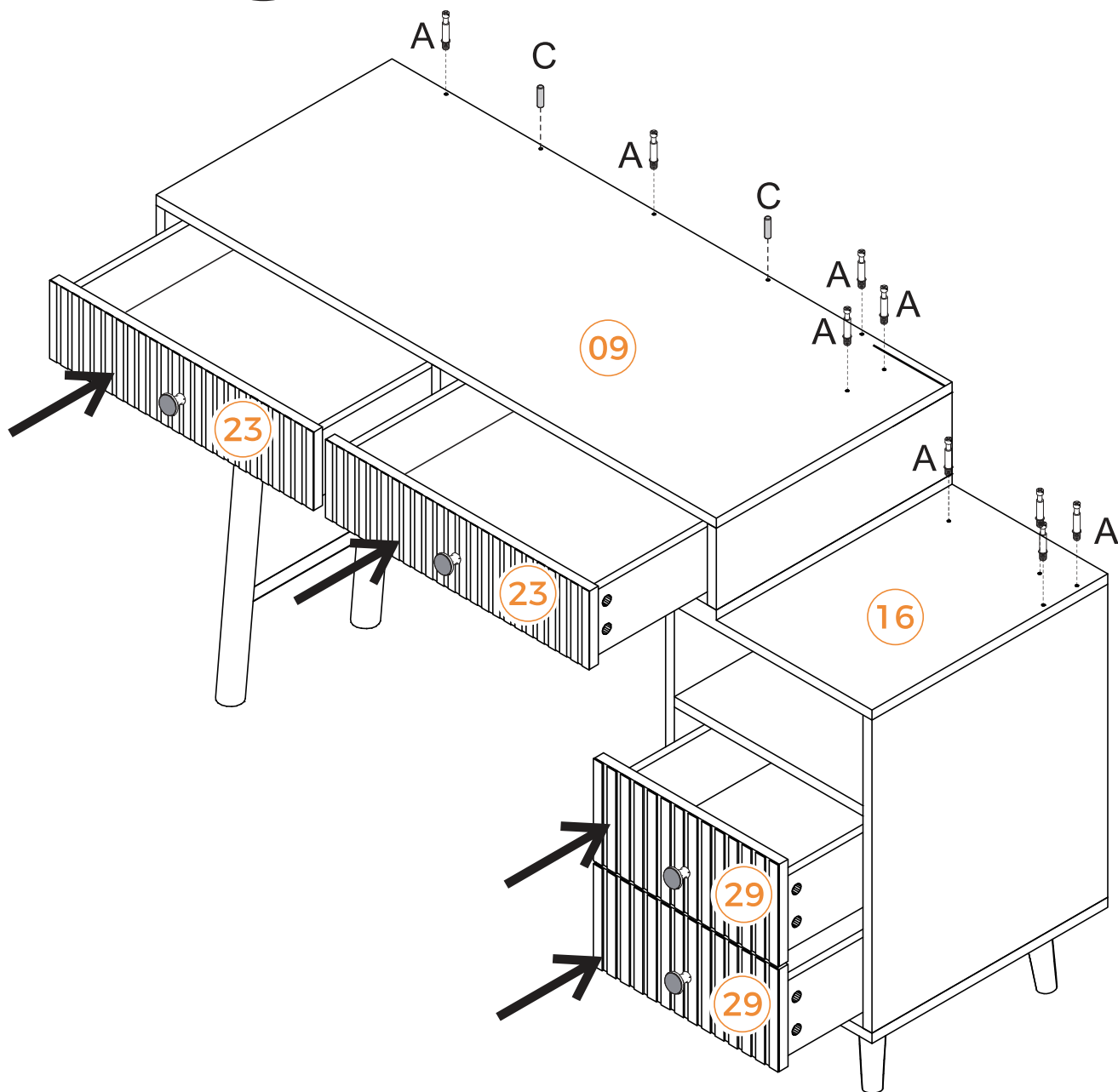



# STEP 17

Please tighten the screws after completing all installation

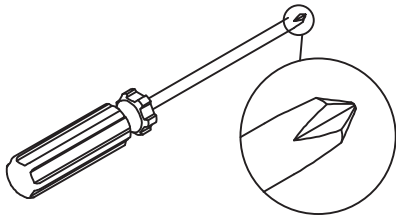
Porfavor, apriete lostornillos despuesde instalar to do



	
M6x35mm	
A	x 6

	
M15x10mm	
B	x 4

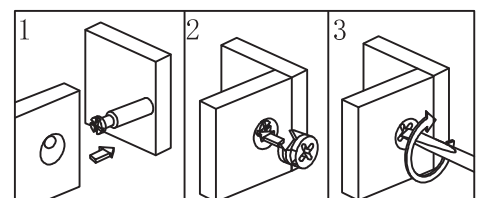
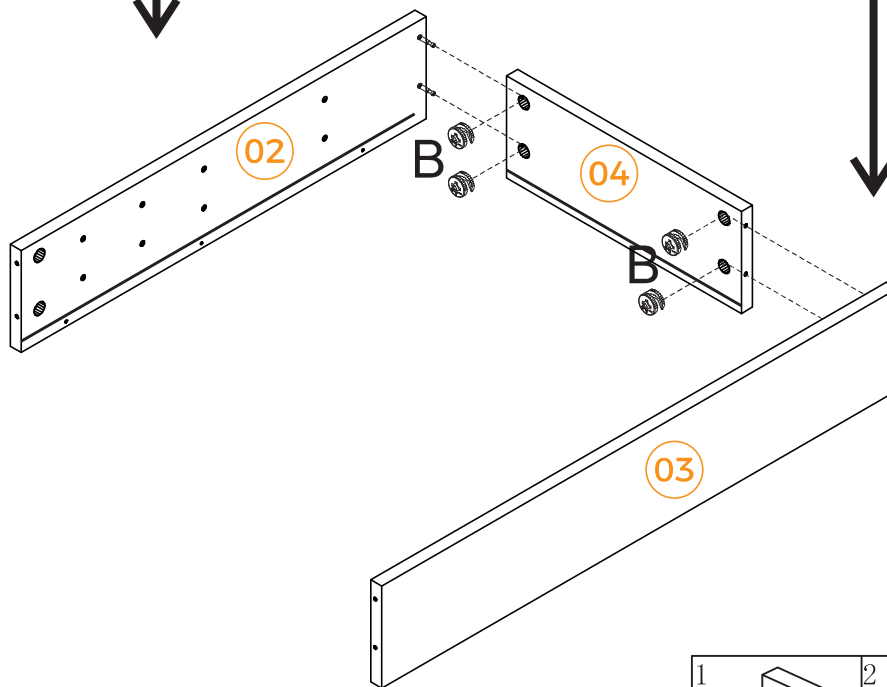
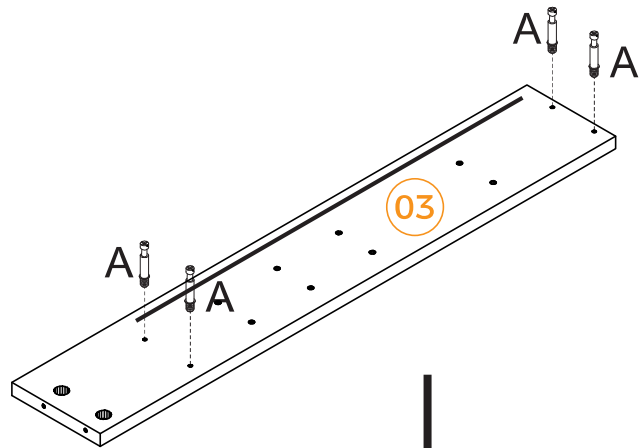
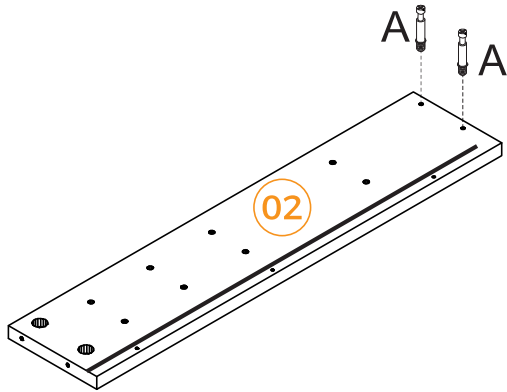

# STEP 18

Please tighten the screws after completing all installation

Porfavor, apriete lostornillos despuesde instalar to do

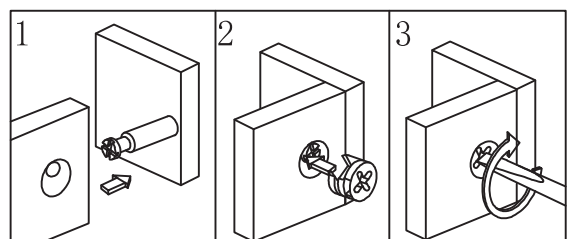
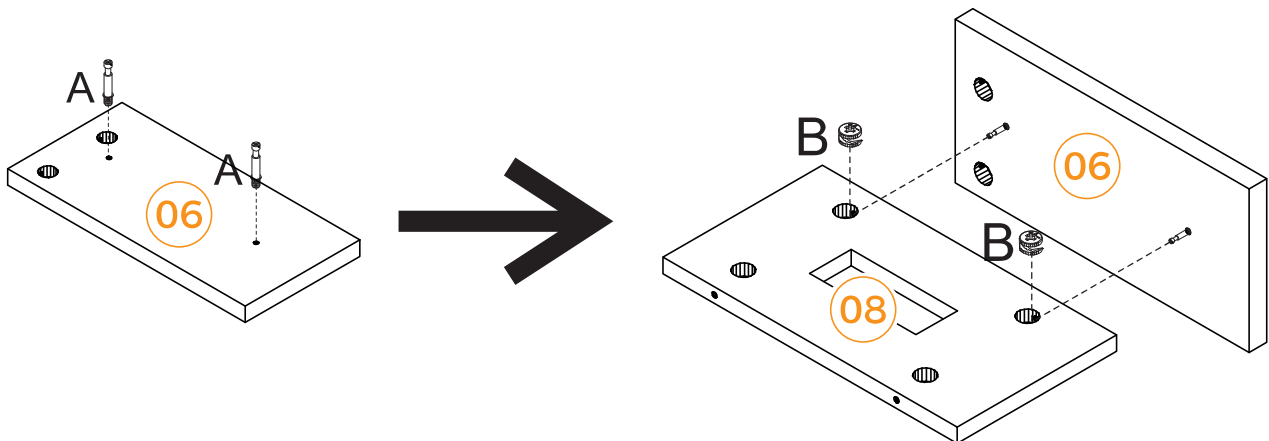
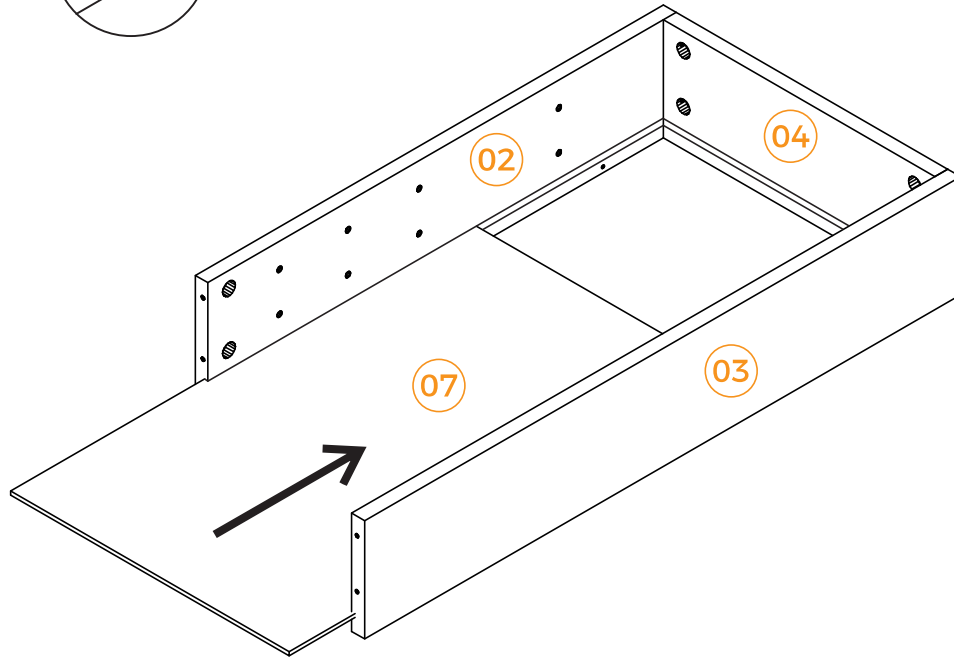
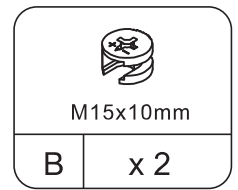
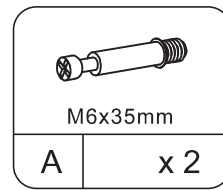
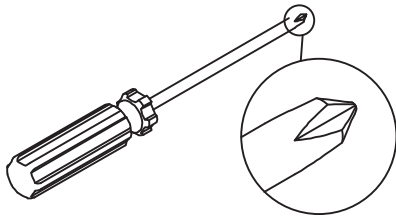

# STEP 19

Please tighten the screws after completing all installation

Porfavor, apriete lostornillos despuesde instalar to do

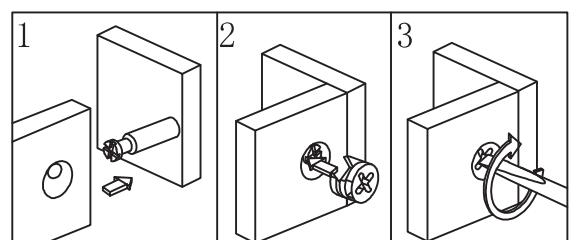
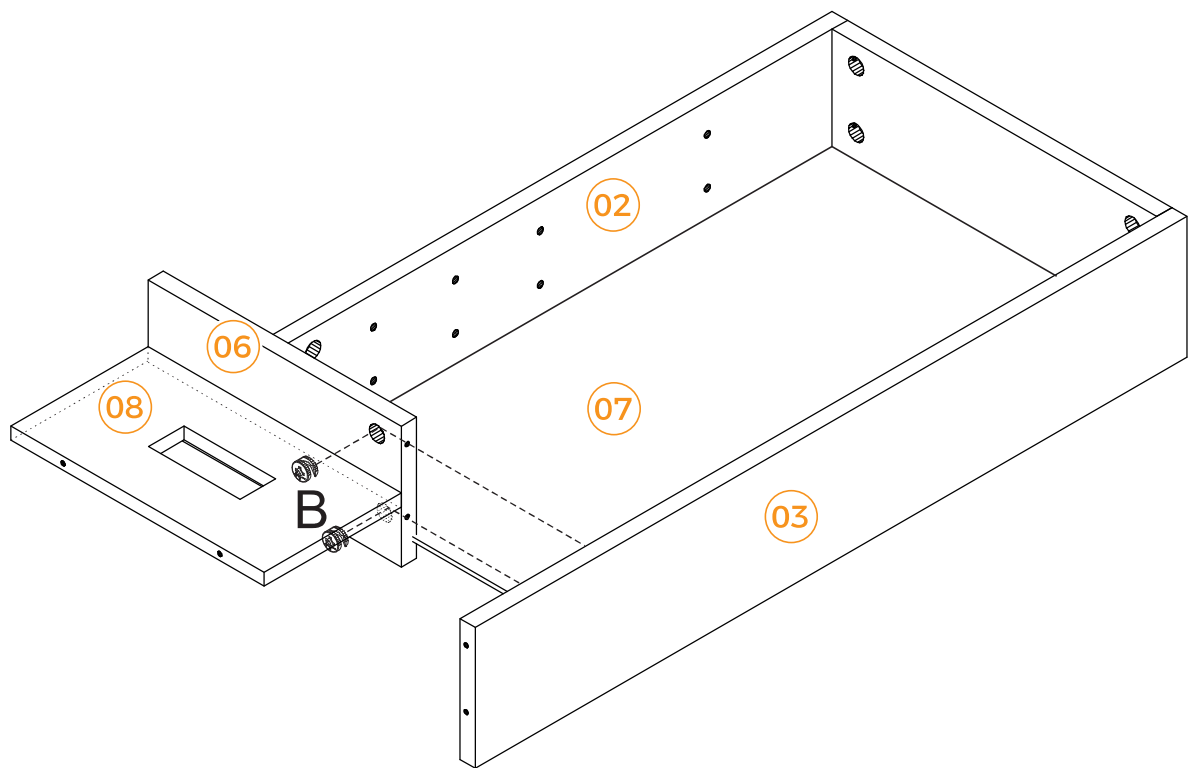
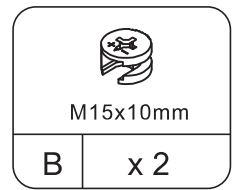
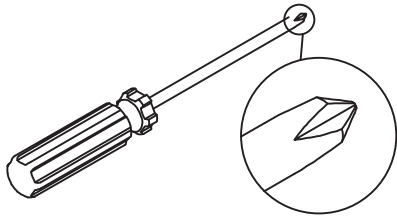

# STEP 20

Please tighten the screws after completing all installation

Porfavor, apriete lostornillos despuesde instalar to do

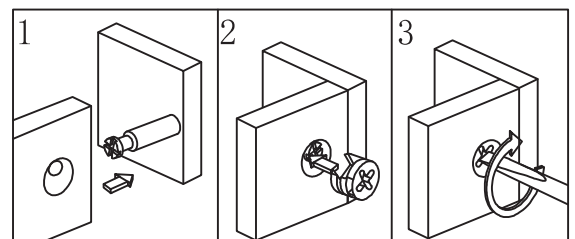
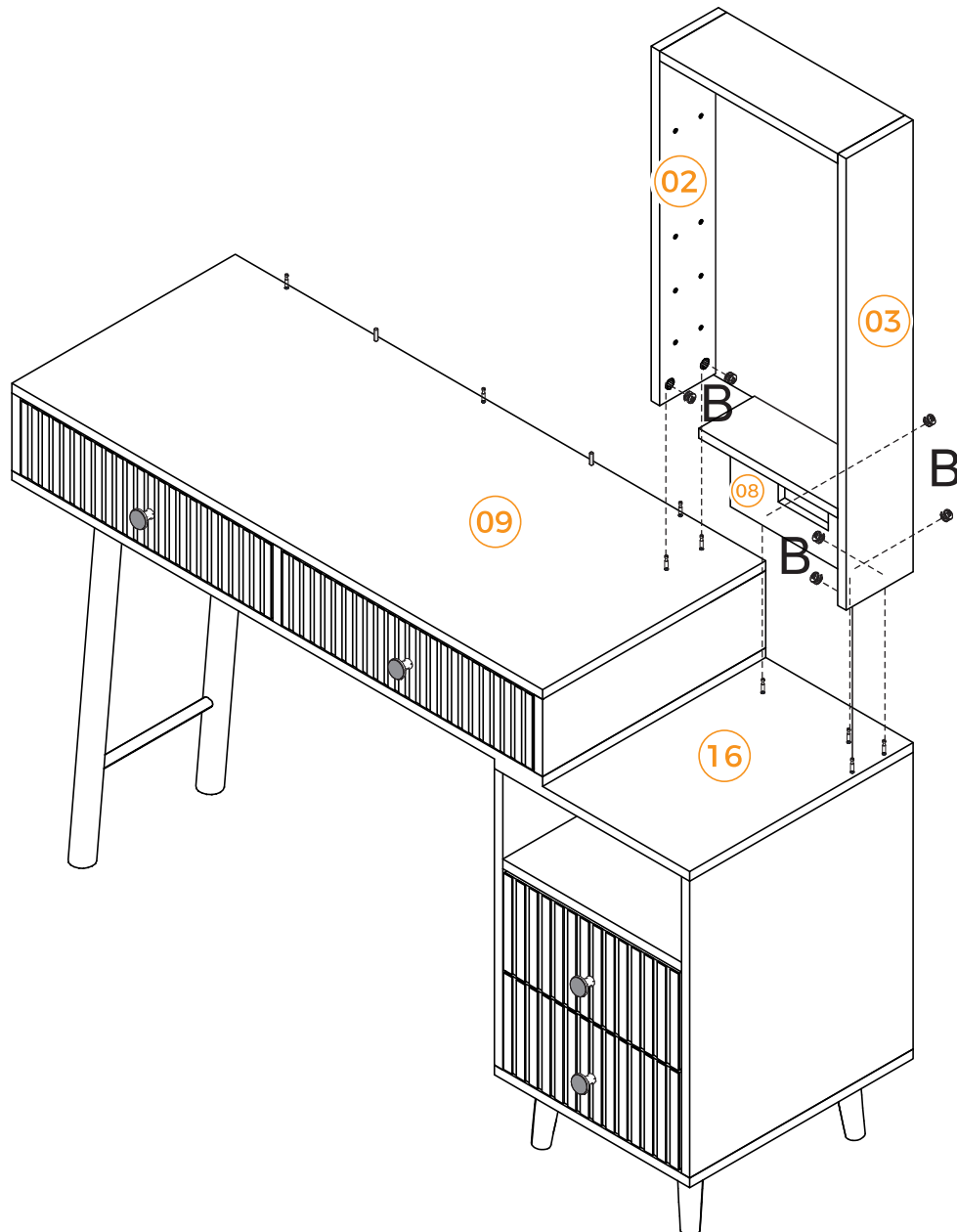
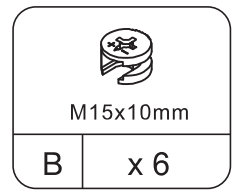
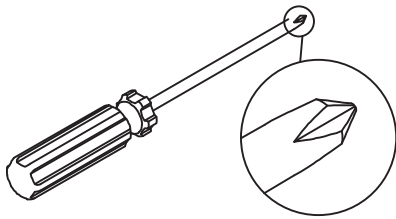



# STEP 21

Please tighten the screws after completing all installation

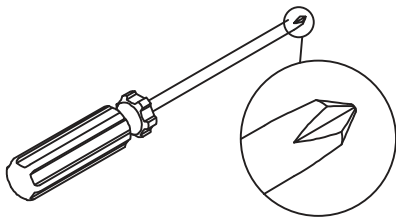
Porfavor, apriete lostornillos despuesde instalar to do



	
M15x10mm	
B	x 3

	
M5x40mm	
D	x 3

	
P	
	x 2

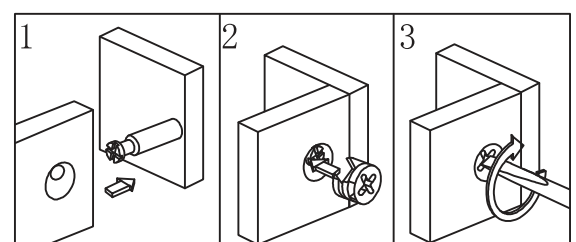
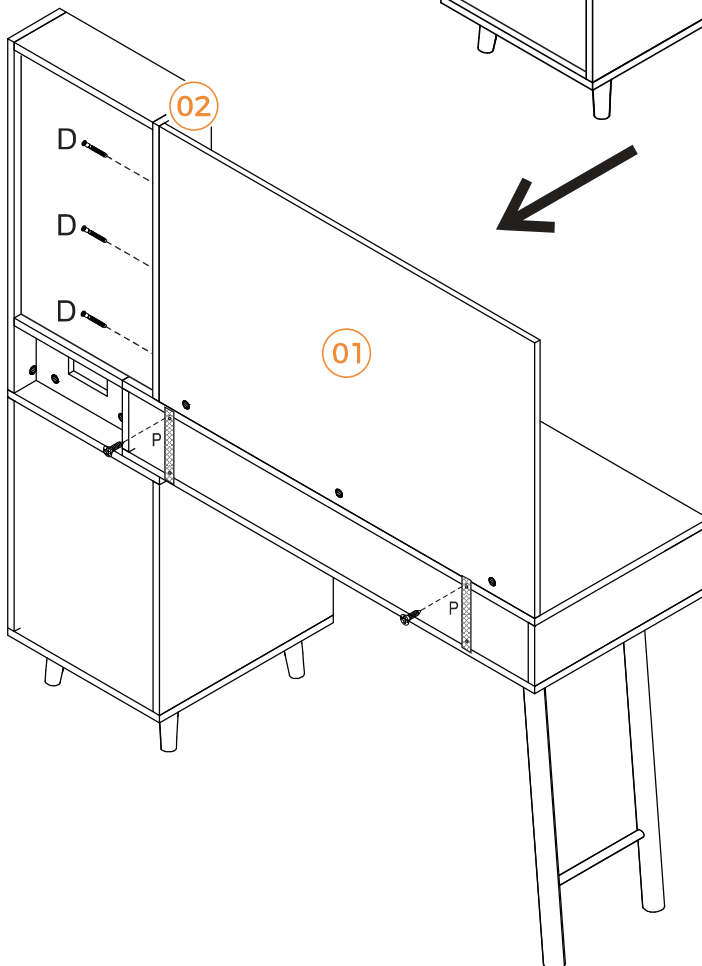
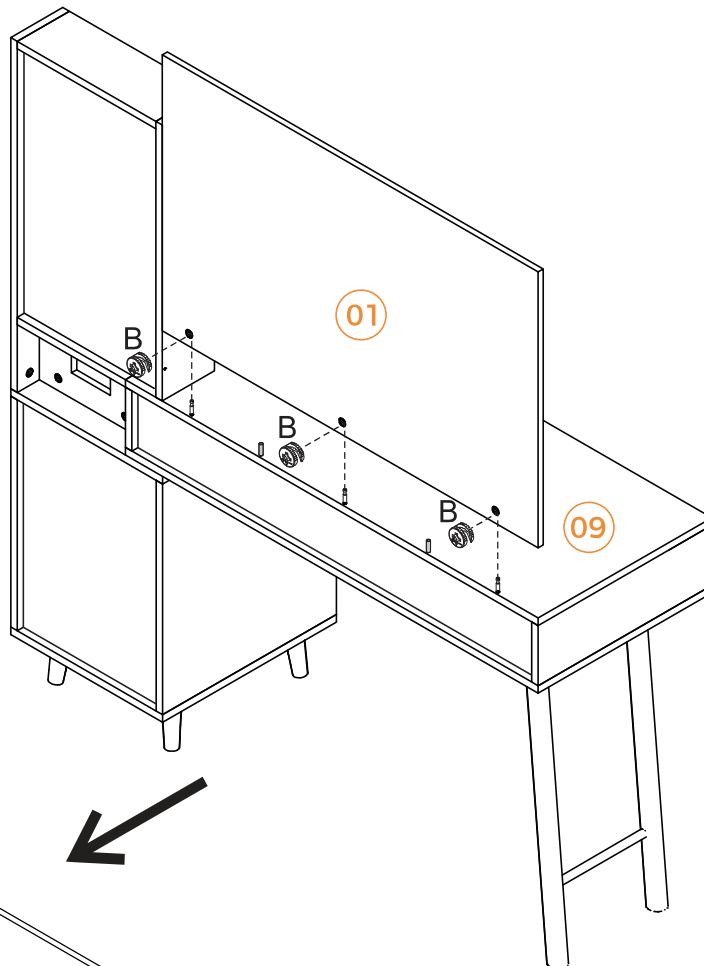

# STEP 22

Please tighten the screws after completing all installation

Porfavor, apriete lostornillos despuesde instalar to do

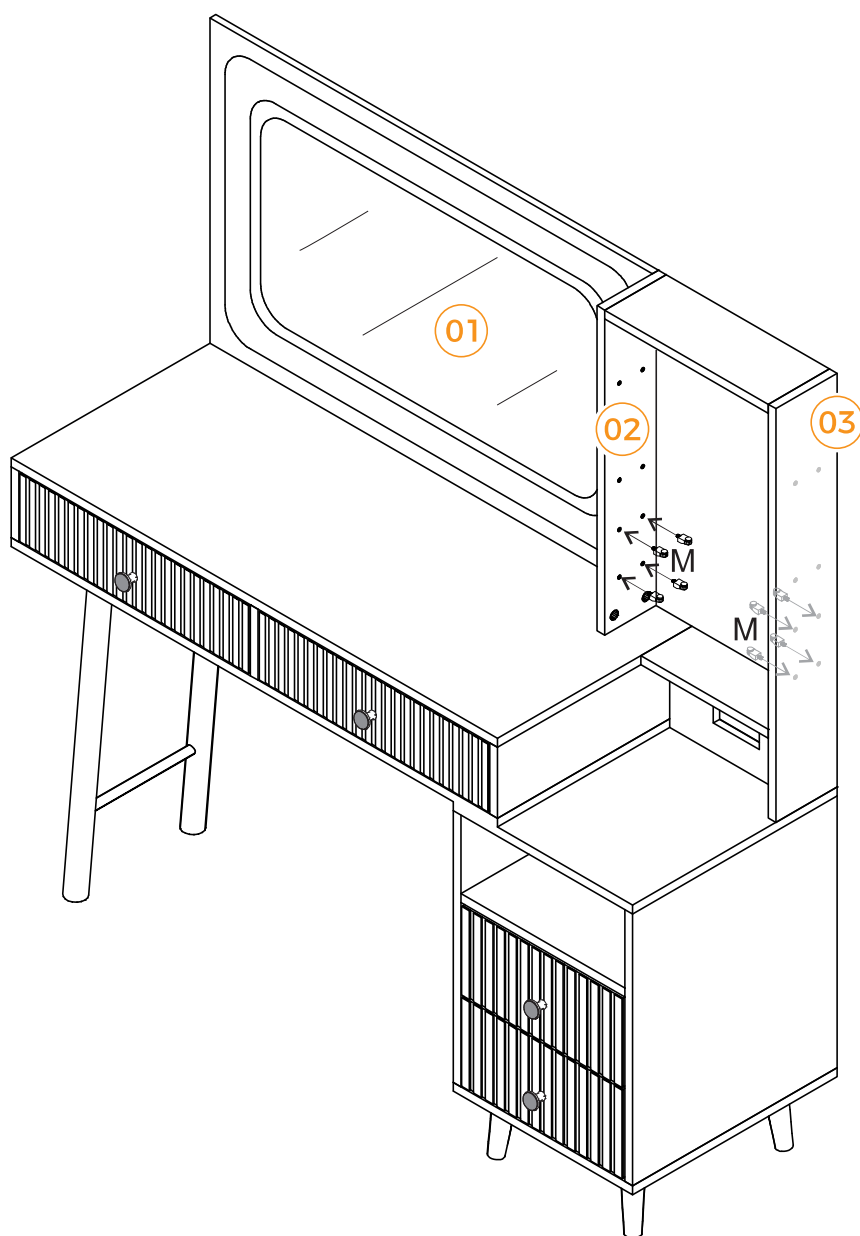
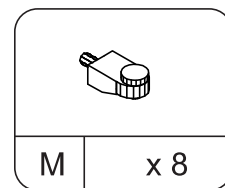

# STEP 23

Please tighten the screws after completing all installation

Porfavor, apriete lostornillos despuesde instalar to do

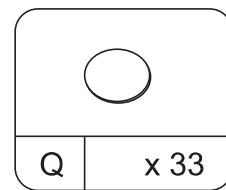
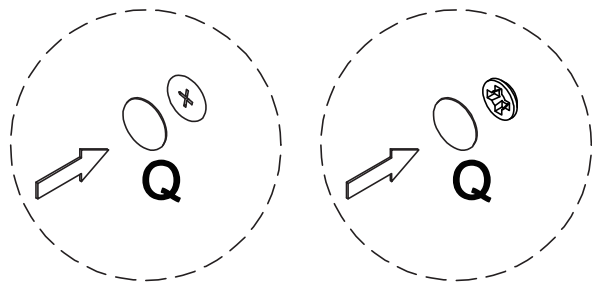

In order to make the product more beautiful, please paste hardware Q on the exposed holes

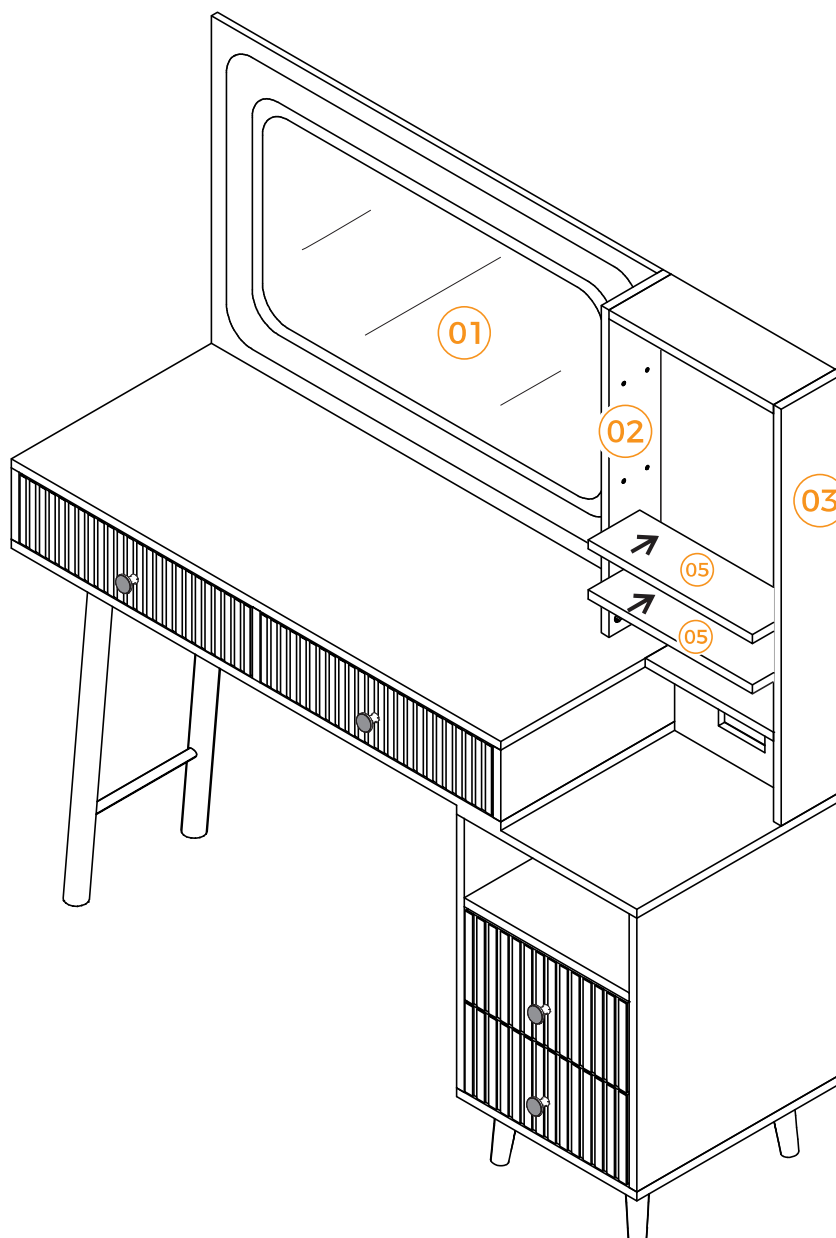

# STEP 24

Please tighten the screws after completing all installation

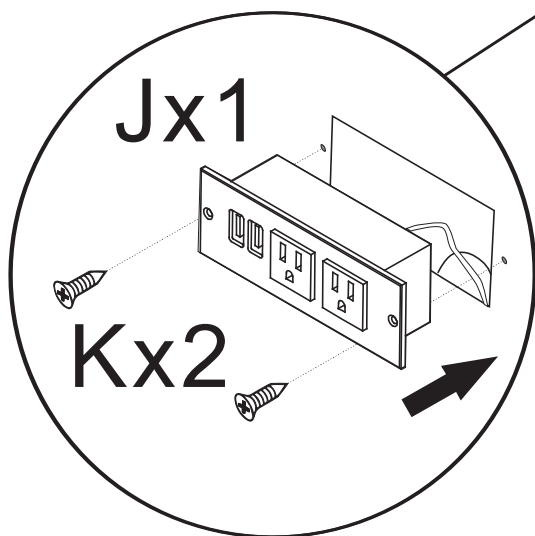
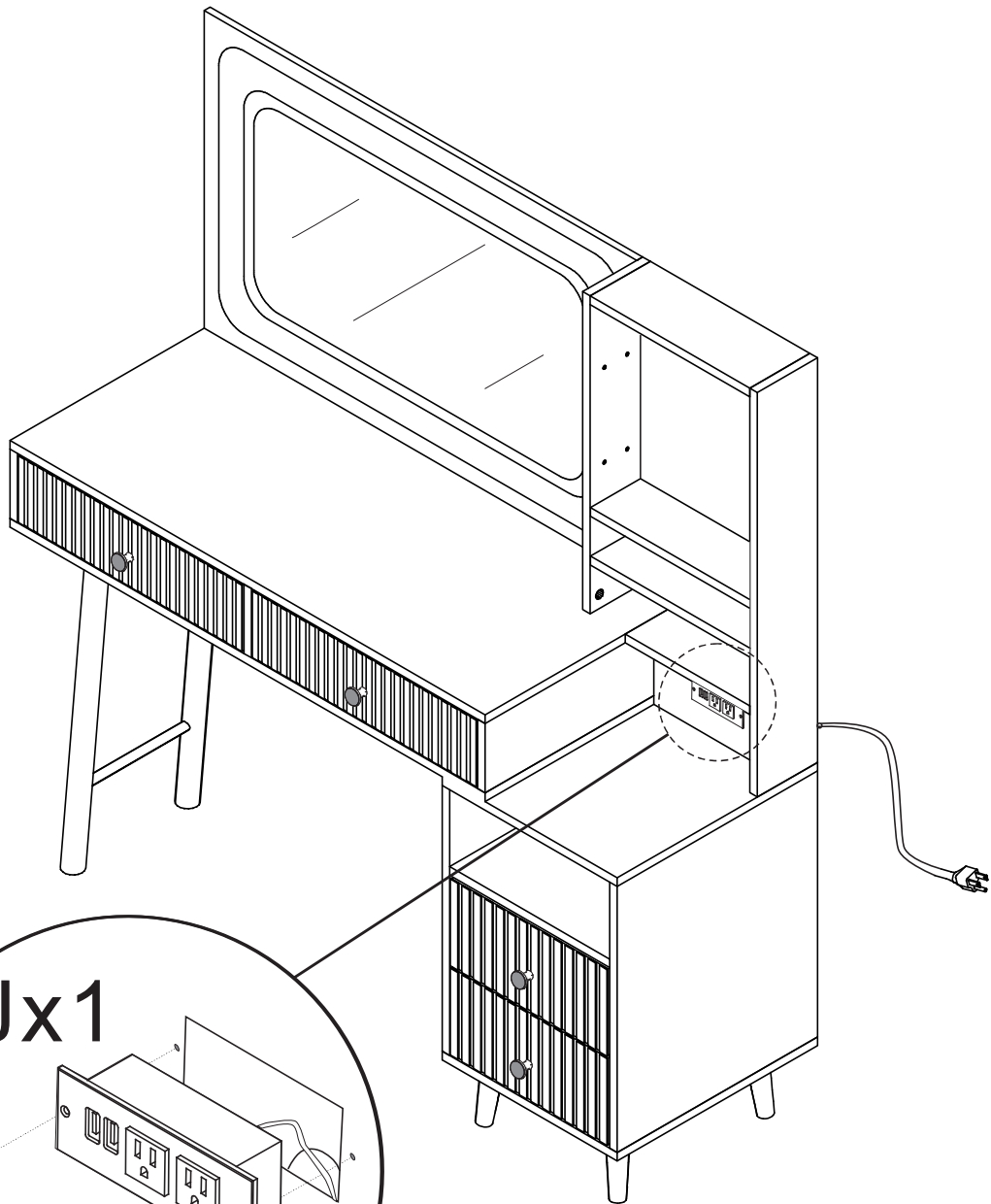
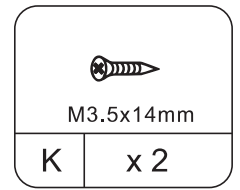
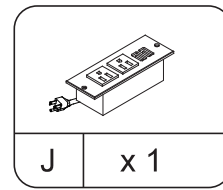
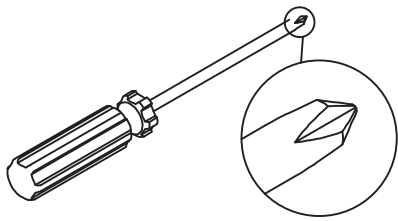

Porfavor, apriete lostornillos despuesde instalar to do



# STEP 25

Please tighten the screws after completing all installation

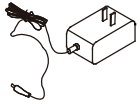
Porfavor, apriete lostornillos despuesde instalar to do

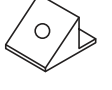
		 M3.5x14mm	
S	x 1	K	x 24
		L	x 2
		R	x 12

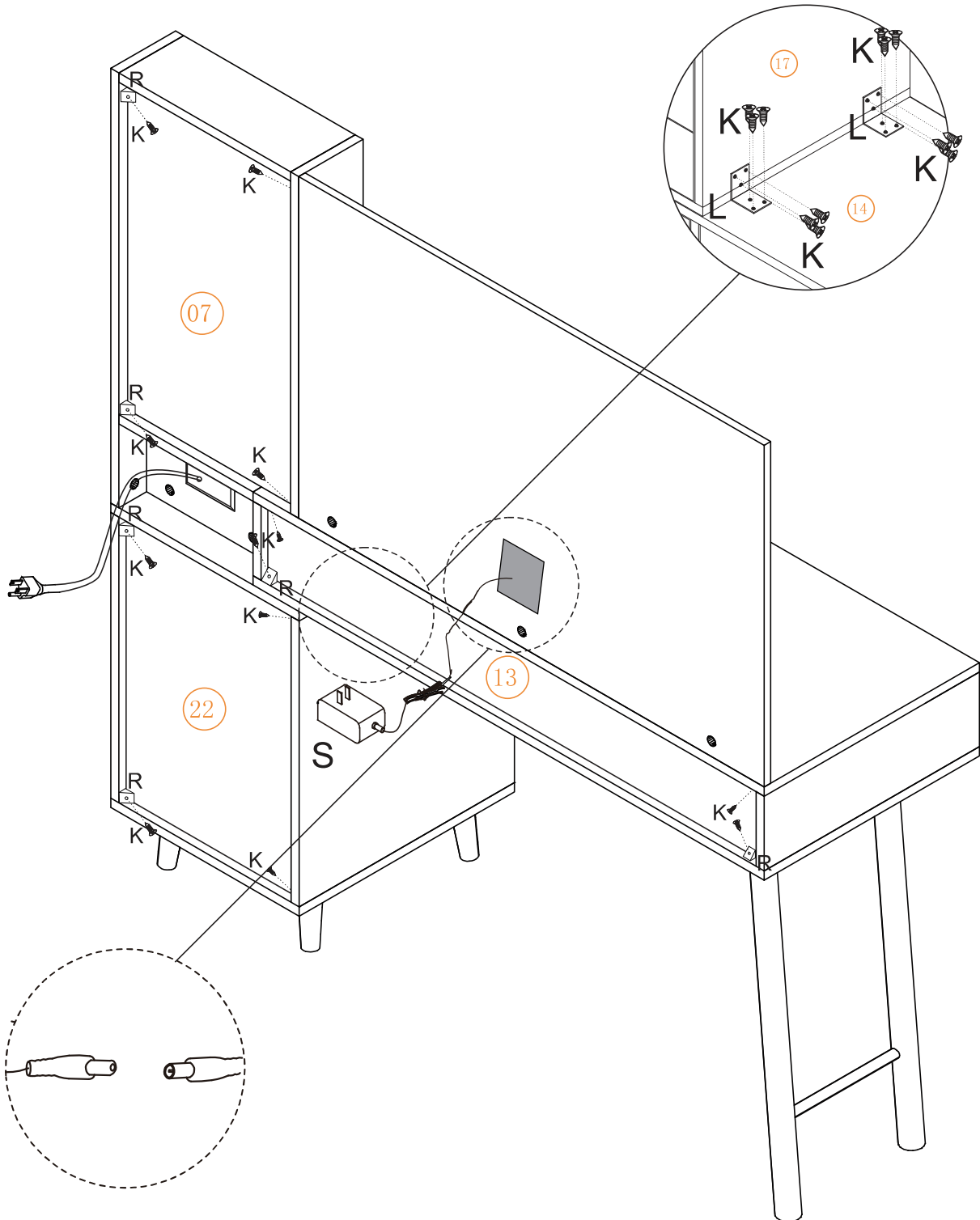

# STEP 26

Please tighten the screws after completing all installation

Porfavor, apriete lostornillos despuesde instalar to do

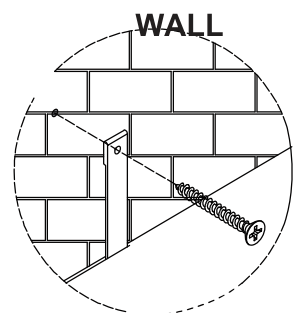
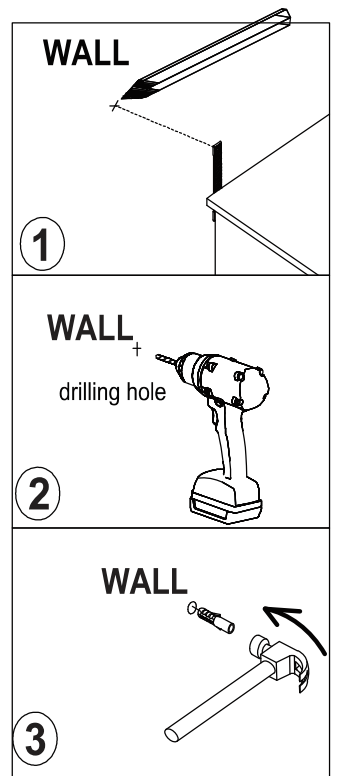
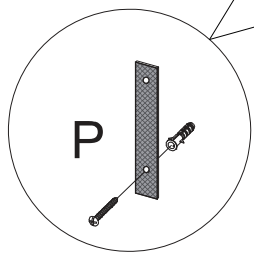
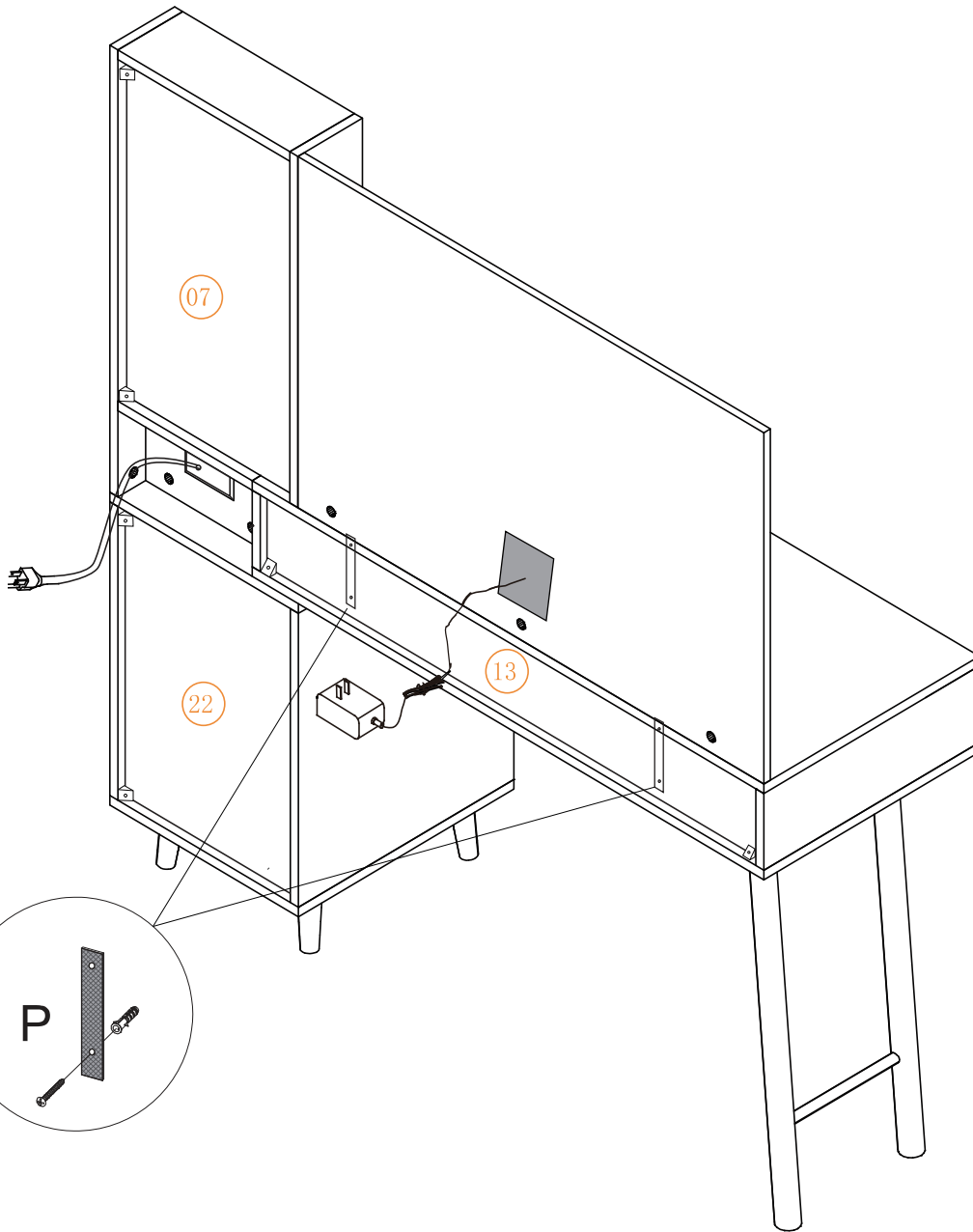
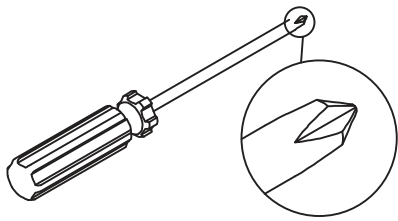
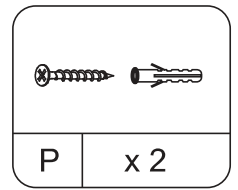

---

# STEP 27

Please tighten the screws after completing all installation

Porfavor, apriete lostornillos despues de instalar to do

---

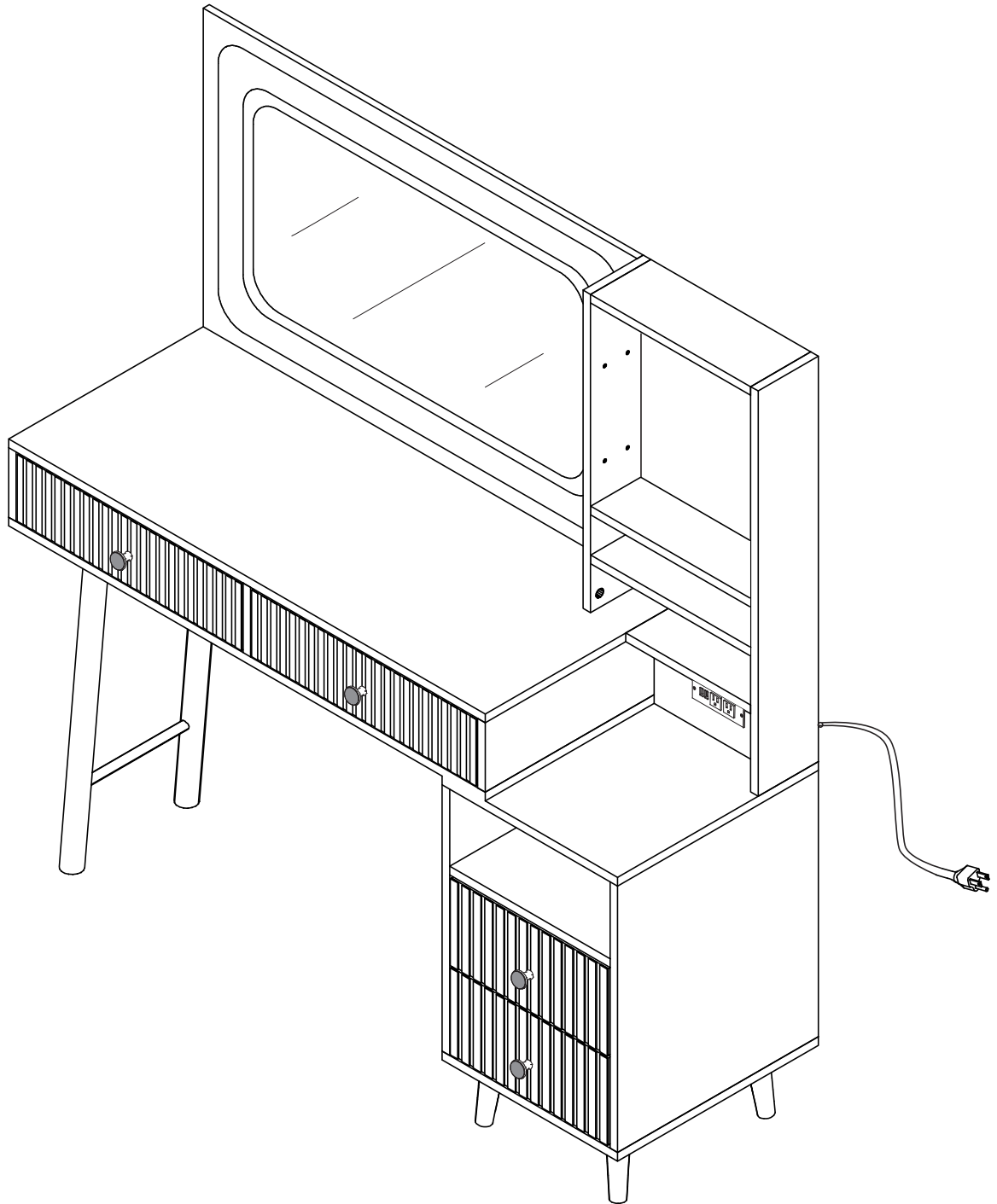



## MAINTENANCE AND CARE

### Prevent Moisture Damage:

Safeguard your laminate furniture by keeping it in a dry environment. Store the furniture away from damp areas and water sources.

### Sunlight Shielding:

Shield your laminate furniture from direct sunlight to prevent color fading and surface deterioration. Consider using curtains or blinds for protection, especially if direct sunlight exposure is unavoidable.

### Regular Care:

Maintain your laminate furniture's appearance by gently wiping surfaces with a damp cloth. Avoid using overly wet cloths or abrasive cleaning tools.

### Avoid Scratches:

Protect the furniture surface from scratches by refraining from placing sharp or hard objects on it. When moving the furniture, be cautious not to scrape the legs against the floor.

### Proper Weight Distribution:

Prevent structural damage by placing heavy objects on stable support surfaces rather than directly on the laminate furniture's surface. This simple step can prolong the life of your furniture.



## MANTENIMIENTO Y CUIDADO

Evite daños por humedad:

Proteja sus muebles laminados manteniéndolos en un ambiente seco. Guarde los muebles lejos de zonas húmedas y fuentes de agua.

Protéjalos de la luz solar:

Proteja sus muebles laminados de la luz solar directa para evitar la pérdida de color y el deterioro de la superficie. Considere el uso de cortinas o persianas como protección, especialmente si la exposición directa a la luz solar es inevitable.

Cuidado regular:

Mantenga el aspecto de sus muebles laminados limpiando suavemente las superficies con un paño húmedo. Evite utilizar paños demasiado húmedos o herramientas de limpieza abrasivas.

Evite los arañazos:

Proteja la superficie del mueble de arañazos evitando colocar objetos afilados o duros sobre ella. Al mover el mueble, tenga cuidado de no raspar las patas contra el suelo.

Distribución adecuada del peso:

Evite daños estructurales colocando objetos pesados sobre superficies de apoyo estables en lugar de directamente sobre la superficie del mueble laminado. Este sencillo paso puede prolongar la vida de sus muebles.



## WARRANTY INFORMATION

**Warranty Coverage:** Our warranty provides protection against manufacturing defects in materials and workmanship for a specified period from the date of purchase, as outlined in the accompanying warranty documentation.

**Exclusions:** The warranty does not cover damages resulting from misuse, negligence, accidents, normal wear and tear, unauthorized repairs or modifications, improper assembly, or failure to adhere to the care and maintenance guidelines provided.

## WARRANTY CLAIM PROCESS

**To initiate a return, please follow these steps:**

1. Log into your account and go to the "Your Orders" section.
2. Locate the order containing the item you wish to return.
3. Contact our customer service for assistance in obtaining a prepaid return label.
4. Once you receive the return label, securely affix it to the package.
5. You can then choose to drop off the package at a designated carrier location or arrange for a pickup.
6. After we receive and inspect the returned product, we will initiate the refund process.
7. The refund will be credited back to the original payment method used during the purchase.
8. Typically, refunds are processed within 3-5 business days.



## INFORMACIÓN SOBRE LA GARANTÍA

**Cobertura de la garantía:** Nuestra garantía proporciona protección contra defectos de fabricación en materiales y mano de obra durante un período determinado a partir de la fecha de compra, como se indica en la documentación de garantía adjunta.

**Exclusiones:** La garantía no cubre los daños resultantes de uso indebido, negligencia, accidentes, desgaste normal, reparaciones o modificaciones no autorizadas, montaje incorrecto o incumplimiento de las directrices de cuidado y mantenimiento proporcionadas. Las directrices de cuidado y mantenimiento proporcionadas.

## PROCESO DE RECLAMACIÓN DE LA GARANTÍA

**Para iniciar una devolución, siga estos pasos:**

1. Accede a tu cuenta y ve a la sección "Tus pedidos".
2. Localiza el pedido que contiene el artículo que deseas devolver.
3. Ponte en contacto con nuestro servicio de atención al cliente para que te ayuden a obtener una etiqueta de devolución prepagada.
4. Una vez que reciba la etiqueta de devolución, fíjela firmemente al paquete.
5. A continuación, puede optar por depositar el paquete en el lugar designado por el transportista o solicitar que lo recojan.
6. Después de que recibamos e inspeccionemos el producto devuelto, iniciaremos el proceso de reembolso.
7. El reembolso se abonará de nuevo al método de pago original utilizado durante la compra.
8. Normalmente, los reembolsos se procesan en un plazo de 3 a 5 días laborables.