

# Assembly Instructions

## Item No. : 51003-WBN-T

Thank you for purchasing our products. Please review the assembly diagram before starting.  
 Note: Insert all screws/bolts loosely first. Once the item is fully assembled, positioned upright, and leveled, then tighten all screws/bolts completely.

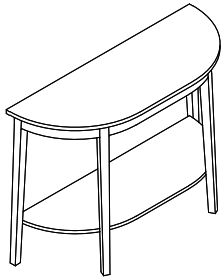

### PARTS LIST

NO.	DESCRIPTION	Q' ty
A	Top Frame	1
B	Shelf	1
C	Front Leg	2
D	Left Back Leg	1
E	Right Back Leg	1

### HARDWARE LIST

NO.	DESCRIPTION	Q' ty	
F	Flat washer	Φ 1/4" * 16mm	16
G	Lock washer	Φ 1/4"	16
H	Screw	Φ 1/4" * 1/2" L	8
I	Screw	Φ 1/4" * 1-3/4" L	4
J	Screw	Φ 1/4" * 2-1/4" L	4
K	Connecting Metal	1-1/4" * 7/8" * 3/4" * 1/8"	4
L	Allen Wrench	4mm	1
M	Screw	Φ 1/4" * 3/4" L	4

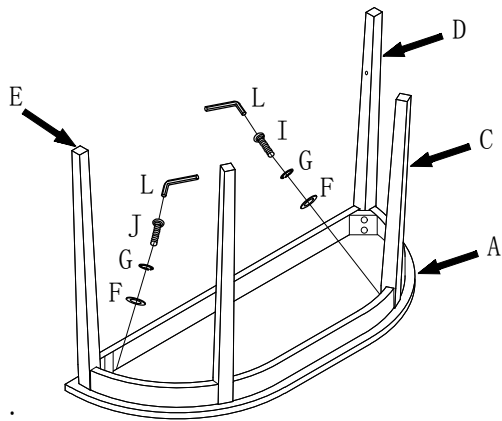

**Step 1:**  
 Place the face frame (A) face down on a flat surface. Secure the 2 legs (D/E) to the face frame (A) with screws (J), spring washers (G) and flat washers (F) in sequence (you need to be careful to differentiate between the left and right legs), then secure the 2 legs (C) to the face frame (A) with screws (I), spring washers (G) and flat washers (F).

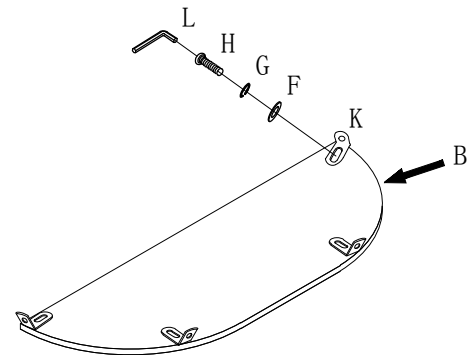

**Step 2.**  
 Place the Base Plate (B) face down on a flat surface. Secure the L-shaped iron piece (K) to the base plate (B) using the screws (H), spring washers (G), and flat washers (F) in the following order.

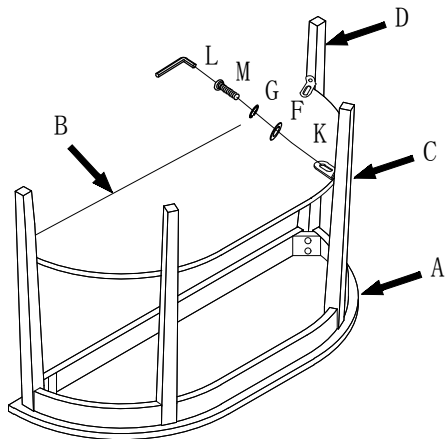

**Step 3.**  
 Place the laminate (B) face down into the slot in the table leg. Secure the laminate (B) to the four legs (C, D, and E) with the screws (M), spring washers (G), and flat washers (F) through the metal L-shaped iron tabs (K), and make sure that all the screws are tightened securely.

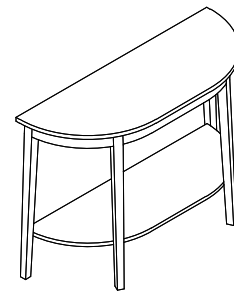

Use fittings according to the actual screw holes, extra fittings are spares