

STEP 4

Attach Panel (B) to the assembled unit with Small Round Leg (7), Round Pole (5) and Screw (3).

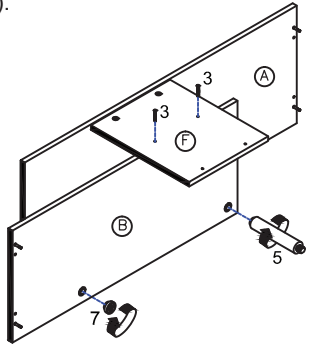

STEP 5

Attach Panel (C) with Small Round Leg (7) and Screw (3).

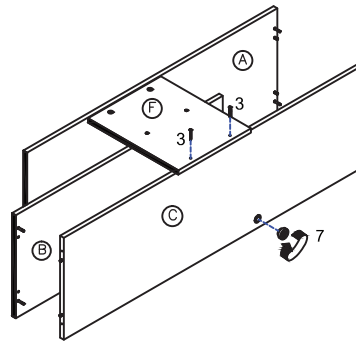

STEP 6

Attach Right Side Panel (E) with Screw (3).

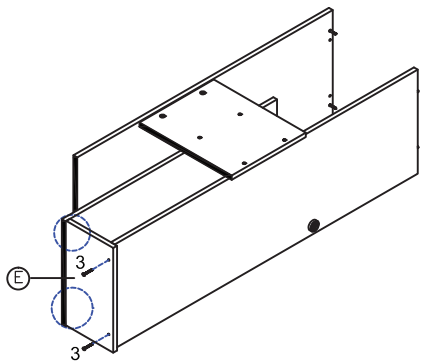

STEP 7

7.1 Attach Left Side Panel (D) with Screw (3) and lock the Mini Fix Cam (2), as shown.
7.2 Cover the Screw with Screw Sticker (8).

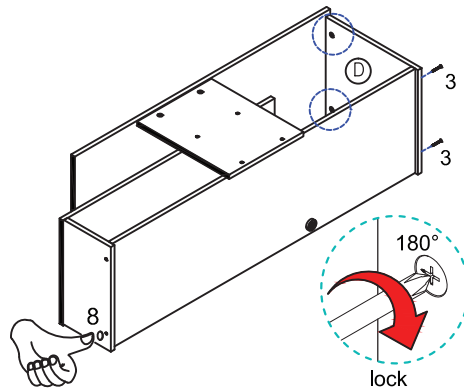

Recommended Maximum Weight

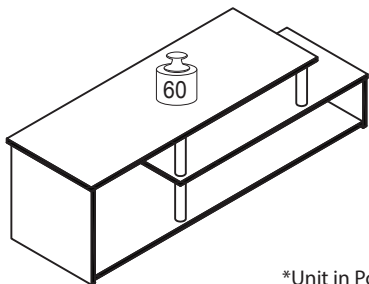

*Unit in Pound(lbs)

WARNING:

>This unit has been designed to support the maximum loads shown. Exceeding these load limits could cause sagging, instability, product collapse, and/or serious injury.

>DO NOT allow children to climb on unit.

>Put heavier items on lower shelves.

Assembly Instruction

Low Rise TV Stand

00:30

Approx. 30 minutes



Recomm. 2 Person

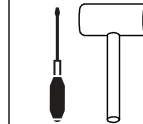

Tool Required

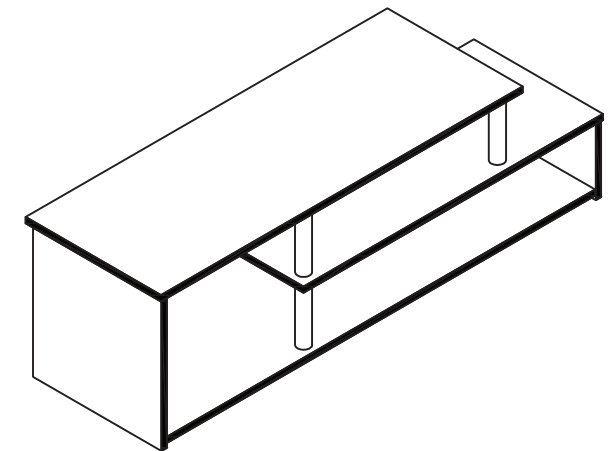

No	Hardware List	Qty
1	Mini Fix Bolt	6pcs
2	Mini Fix Cam	6pcs
3	Screw	8pcs
4	Dowel	8pcs
5	Round Pole	3pcs
6	Insert Cap	2pcs
7	Small Round Leg	2pcs
8	Screw Sticker	4pcs
9	Nail Leg	6pcs

No	Parts List	Qty
A	Top Panel	1pc
B	Shelf Panel	1pc
C	Bottom Panel	1pc
D	Left Side Panel	1pc
E	Right Side Panel	1pc
F	Back Panel	1pc

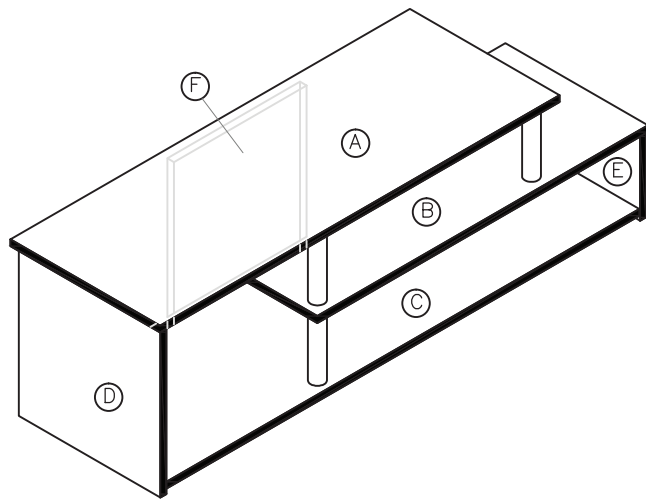

USEFUL HINTS BEFORE YOU START:

1. Read each step carefully before starting.
2. It is important that each step is performed in correct order to avoid difficulties.
3. Identify, sort and count the parts before assembly.
4. Assemble your furniture on packaging cardboard to prevent scratch or damage.
5. Clean the product with mild cleanser using soft damped cloth. Do not use harsh or abrasive cleanser.
6. Using incompatible hardware might cause damage to product.

STEP 1

- 1.1 Insert Mini Fix Bolt (1) into Panel (A&B).
- 1.2 Press Insert Cap (6) into Panel (A) with a little pressure .
- 1.3 Insert Dowel (4) into Panel (C,D&E).
- 1.4 Insert Mini Fix Cam (2) and Nail Leg (9) into Panel (D,E&F), as shown.

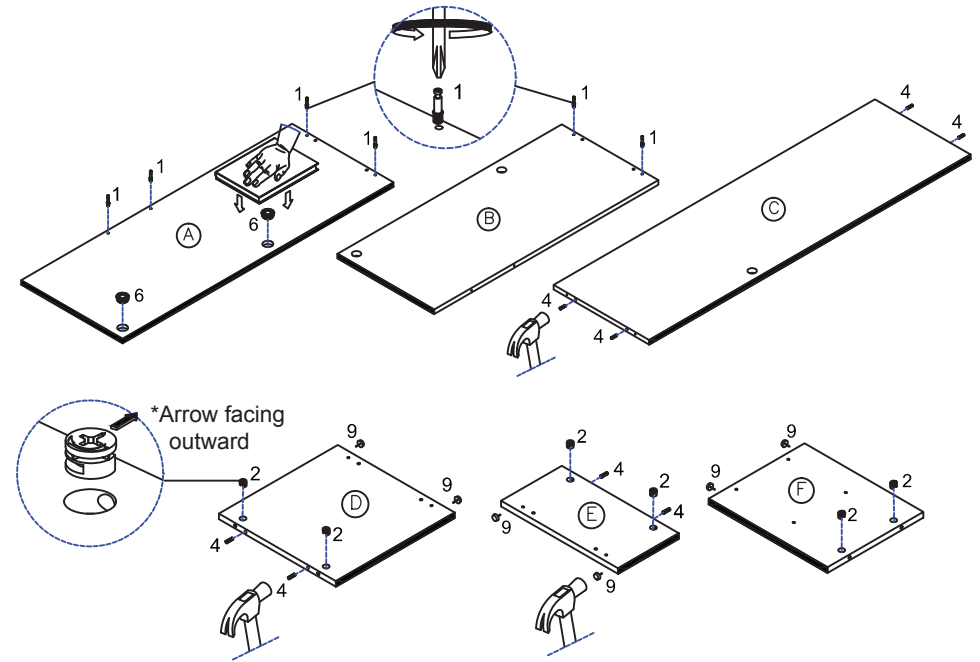

STEP 2

Attach Round Pole (5) to Panel (A).

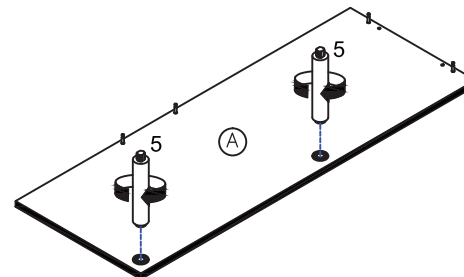

STEP 3

Attach Panel (F) to assembled unit and lock the Mini Fix Cam (2), as shown.

