

General Guidelines

- Please read the following instruction carefully and use the product accordingly.
- Please keep this manual and hand it over when you transfer the product.
- This summary may not include every detail of all variations and considered steps. Please contact us when further information and help are needed

Notes

- The product is intended for indoor use only. The product must be assembled and used in accordance with the provisions of the manual. Personal injury and/or damage to product may occur if products are used outside of their intended purposes and/or if products have been changed/modified from their original design. The seller does not assume any responsibility or liability with respect to any injury/damage caused by incorrect assembly or improper use.
- Keep the product away from fire sources and high temperatures.
- Please assemble the item on a spacious surface and do not place the unwrapped product directly on the ground to avoid product damage.
- Please wear gloves during the assembly and/or disassembly process to avoid scratches from any sharp edges.
- Please match the corresponding part and fitting based on the part number in the manual.
- Periodically inspect screw tightness while the product is in use. If necessary, retighten to ensure structural integrity.
- If you accidentally spill water or another liquid on the surface, immediately wipe clean with a dry towel.
- Please place this item on level, solid ground during use.

Warnings

- It is not intended for use by children under 3 years of age. Children must be under adult supervision to use the product.
- Children should not climb or play on the product in order to avoid tipping over the furniture and causing serious injury.
- During assembly, keep all small parts out of the reach of children. It may be fatal if swallowed or inhaled.
- To avoid the potential dangers of suffocation, please keep all parts and packaging (film, plastic bags, foam, etc.) away from babies and children.

Introduction

- Lisez attentivement ces instructions et utilisez votre produit d'après ce mode d'emploi.
- Conservez ces instructions. Si vous souhaitez offrir ce produit à un tiers, joignez obligatoirement ce mode d'emploi.
- Pour des raisons de clarté, les détails concernant chaque variante ou montage envisageable ne peuvent être tous décrits. Si vous souhaitez obtenir plus d'informations ou si vous rencontrez certains problèmes non traités de manière détaillée dans ces instructions, veuillez nous contacter.

Notes

- Le produit est destiné uniquement à un usage intérieur. Il doit être assemblé et utilisé conformément aux instructions. Les utilisations qui ne correspondent pas à la description ci-dessus ou les transformations de l'article ne sont pas autorisées. Le vendeur ne prend aucune responsabilité des dommages causés par un montage incorrect ou une utilisation non conforme.
- Éloignez le produit de toute source d'incendie et des températures élevées.
- Veuillez assembler le produit sur une surface spacieuse et ne pas placer le produit déballé directement sur le sol pour éviter d'endommager le produit.
- Veuillez porter des gants pendant le montage et le démontage afin de ne pas vous blesser.
- Veuillez faire correspondre la pièce et la ferrure correspondantes en vous basant sur le numéro de pièce figurant dans le manuel.
- Vérifiez régulièrement le serrage des vis. En cas de nécessité, resserrez-les.
- Si vous renversez de l'eau ou un autre liquide sur la surface, essuyez-la immédiatement avec une serviette sèche.
- Veuillez placer le produit sur une surface plane et solide pendant l'utilisation.

Avertissements

- L'usage de ce produit n'est pas recommandé pour l'enfant de moins de 3 ans. Si nécessaire, il doit être sous la supervision de l'adulte.
- Pour éviter des blessures causées par le renversement du produit, il est interdit de monter sur le produit ou le traîner.
- Durant le montage, gardez les enfants loin de la zone de travail. Le produit comprend beaucoup de petites pièces, l'inhalation et l'avalement de pièces ont un risque mortel.
- Pour éviter le danger inconnu (e.g l'étouffement), gardez toutes les pièces et l'emballage (films, sac plastiques, polystyrènes, etc.) hors de la portée des enfants..

IF HAVE THIS ACCESSORY

NOTE DIFFERENT MODELS

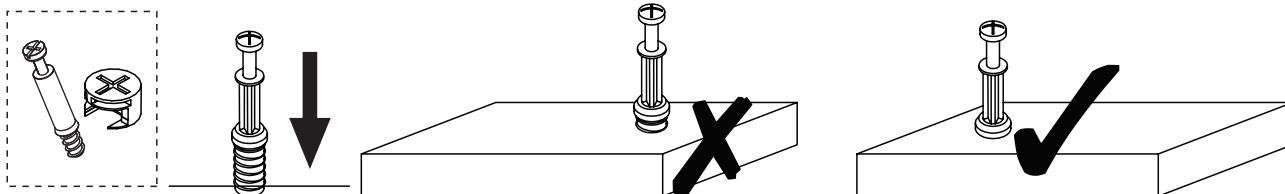

EN_QUICKFIT: Tighten quickfit until shoulder is flush with panel. Do not overtighten or undertighten.

FR_RACCORD RAPIDE: Faites serrer le raccord rapide jusqu'à ce que l'épaulement soit parfaitement encastré dans le panneau. Il ne faut ni trop serrer ni insuffisamment serrer.

ES_QUICKFIT: Apriete quickfit hasta que el hombro se descargue con el panel. NO lo sobreapriete ni lo apriete poco.

PT_AJUSTE RÁPIDO: Aperte o ajuste rápido até estar nivelada com o painel. Não apertar demasiado ou excessivamente.

DE_QUICKFIT: Ziehen Sie den Quickfit fest, bis die Schulter mit der Platte bündig ist. Bitte nicht zu fest oder zu schwach anziehen.

IT_MONTAGGIO RAPIDO: Stringere il montaggio rapido fino a quando la spalla è a filo con il pannello, non stringere troppo o troppo poco.

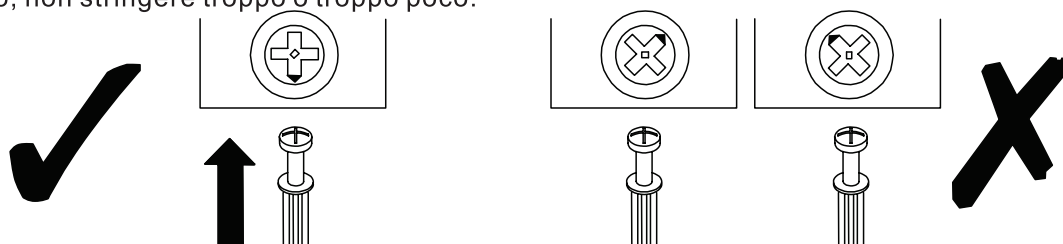

EN_CAM LOCK: When fitting cam lock, ensure starting position is correct before you insert connecting quickfit.

FR_SERRURE BATTEUSE: Avant d'insérer la serrure batteuse, veillez à la bonne orientation avant d'insérer le raccord rapide.

ES_CIERRE DE LA CÁMARA: Cuando instale el cierre de la cámara, asegúrese de que la posición de inicio es correcta antes de que inserte el quickfit conector.

PT_BLOQUEIO: Ao instalar o bloqueio, assegurar-se de que a posição inicial está correcta antes de inserir o encaixe de ligação rápida.

DE_CAM-LOCK: Achten Sie bei der Montage des Cam-Locks auf die richtige Ausgangsposition, bevor Sie den Quickfit einsetzen.

IT_BLOCCAGGIO A CAMMA: Quando si monta il bloccaggio a camma, assicurarsi che la posizione iniziale sia corretta prima di inserire il montaggio rapido di collegamento.

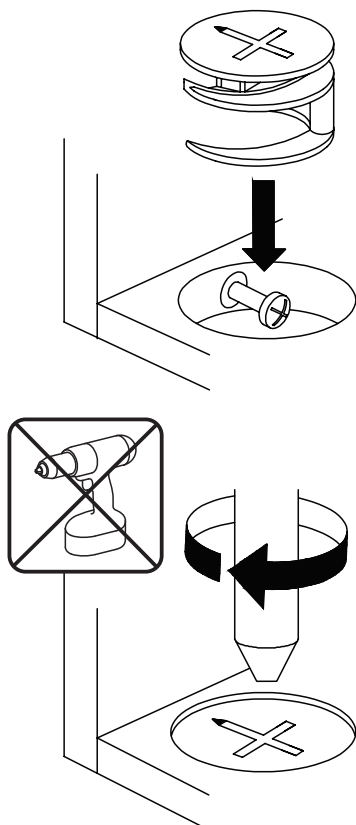

EN_Quickfit head should be in the centre of the cam lock when the two panels are joined.

Cam lock should be inserted before quickfit.

FR_Lorsque les deux panneaux sont assemblés, la tête du raccord rapide doit reposer au centre de la serrure batteuse.

Il faut insérer la serrure batteuse avant le raccord rapide.

ES_El cabezal del quickfit debe estar en el centro del cierre de la cámara cuando se unan los dos paneles.

Se debe insertar el cierre de la cámara antes que el quickfit.

PT_A cabeça de ajuste rápido deve estar no centro da fechadura quando os dois painéis estão unidos.

A fechadura de cames deve ser inserida antes de ser rápida.

DE_Der Quickfit-Kopf sollte sich in der Mitte des Cam-Locks befinden, wenn die beiden Platten zusammengefügt sind.

Der Cam-Lock sollte vor dem Quickfit eingesetzt werden.

IT_La testa del montaggio rapido deve trovarsi al centro del bloccaggio a camma quando i due pannelli sono uniti.

Il Bloccaggio a Camma deve essere inserito prima del montaggio rapido.

EN_Turn cam lock clockwise to tighten.

FR_Faites tourner la serrure batteuse dans le sens des aiguilles d'une montre pour la resserrer.

ES_Gire el cierre de la cámara en sentido horario para apretarlo.

PT_Rodar o bloqueio no sentido dos ponteiros do relógio para o apertar.

DE_Drehen Sie den Cam-Lock im Uhrzeigersinn, um ihn festzuziehen.

IT_Ruotare il bloccaggio a camma in senso orario per stringere.



01
STEP

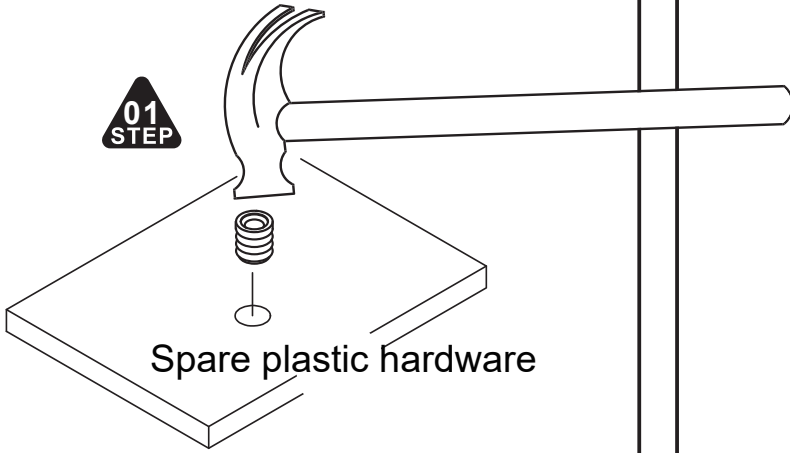

Spare plastic hardware



02
STEP

A1

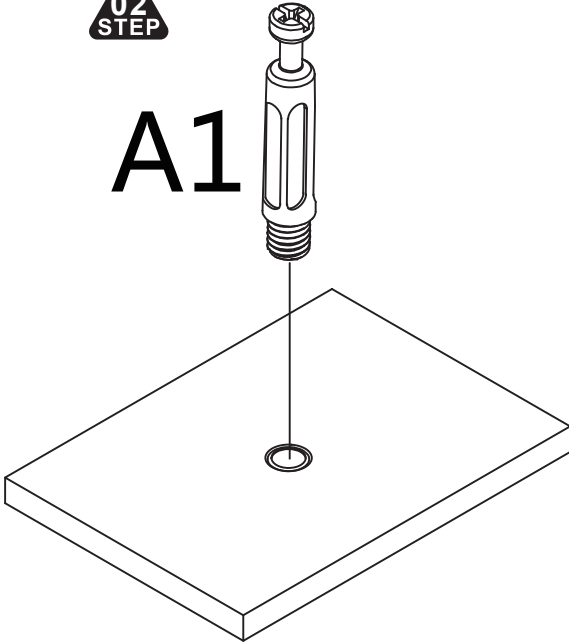

A1

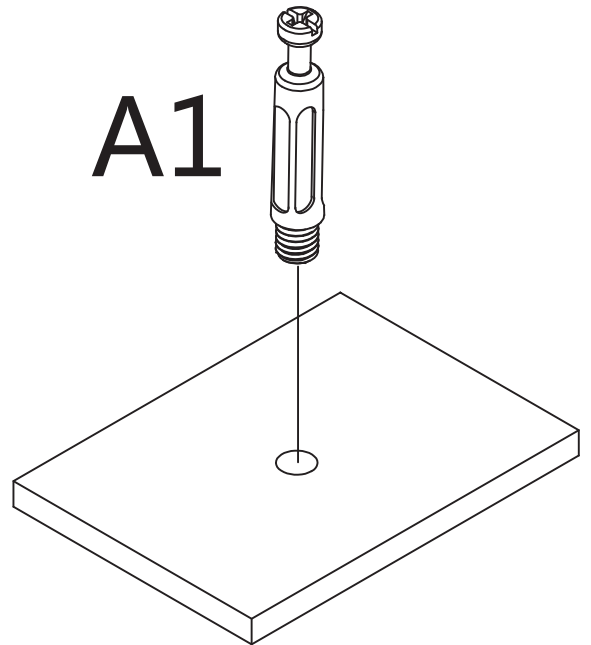

PACKING DETAILS: TOTAL 1 BOX

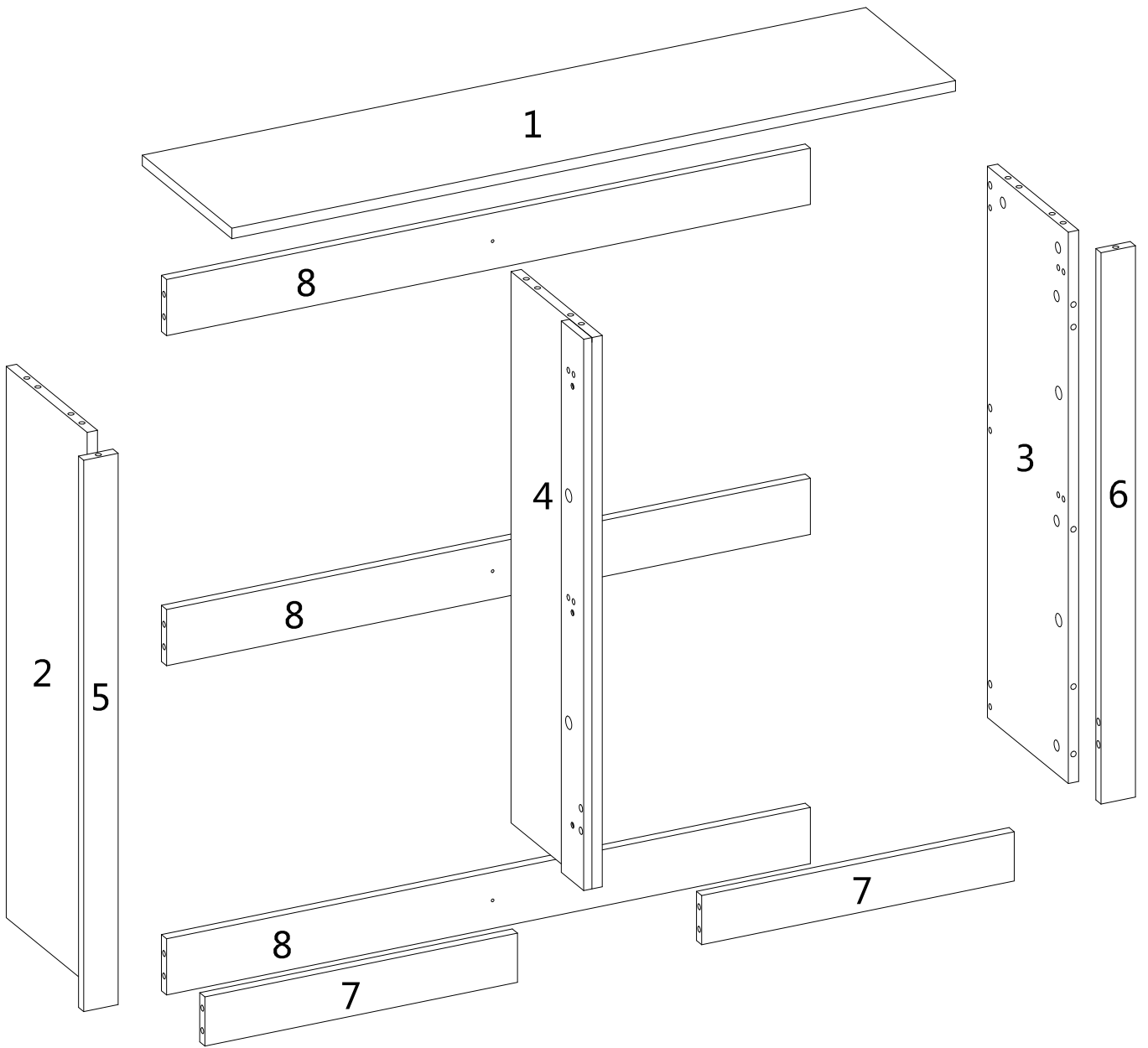

X4

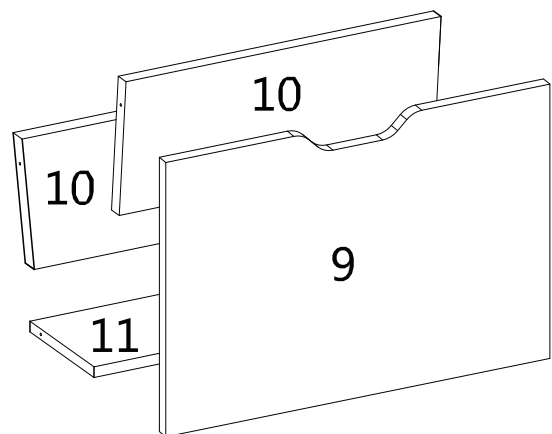

A

Ø15*9.5mm

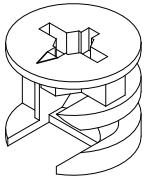

A2

A1

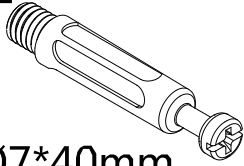

Ø7*40mm

28PCS

B

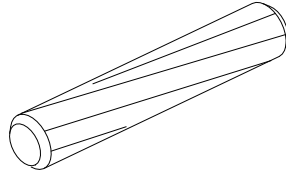

Ø8*30mm

16PCS

C

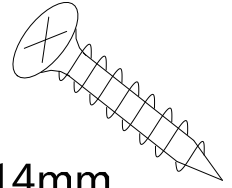

Ø3.5*14mm

56PCS

D

Ø3.5*25mm

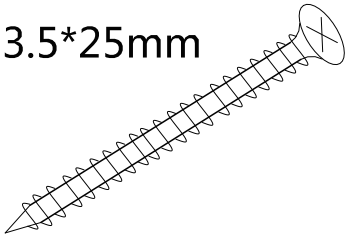

3PCS

E

E1

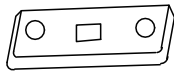

E5

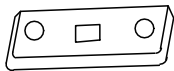
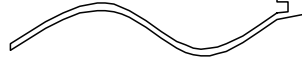

E2

E3

E4

2PCS

F

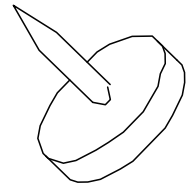

10PCS

G

G1

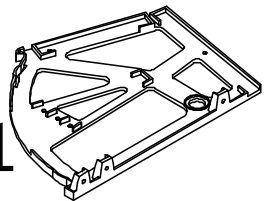

G2

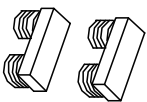
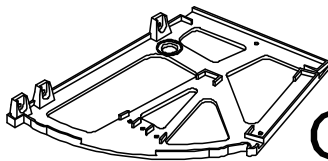

G3



G4

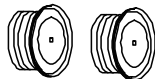

G5

4PCS

H

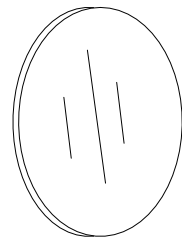

28PCS

1

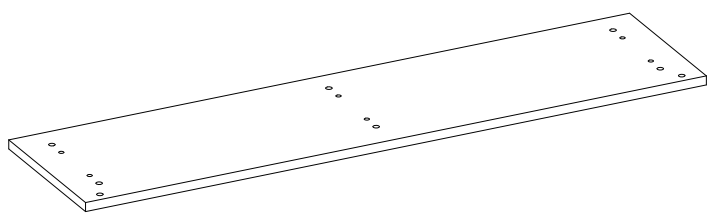

1051*260mm

2

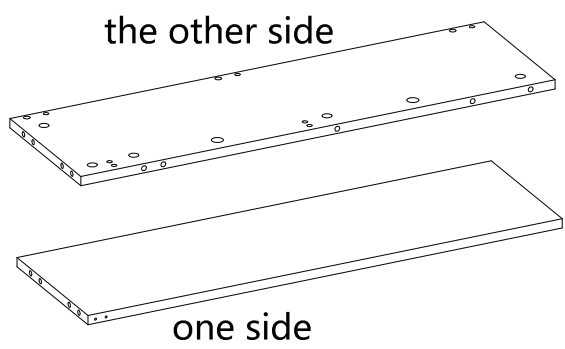

785*235mm

3

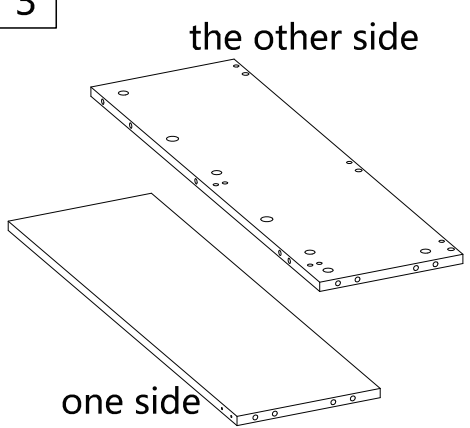

785*235mm

4

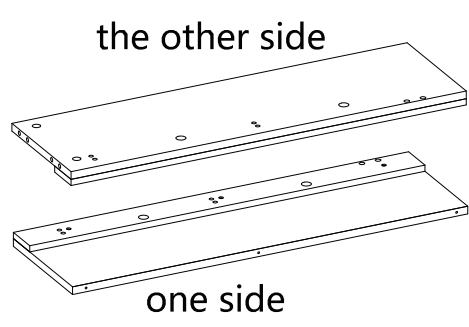

785*235mm

5

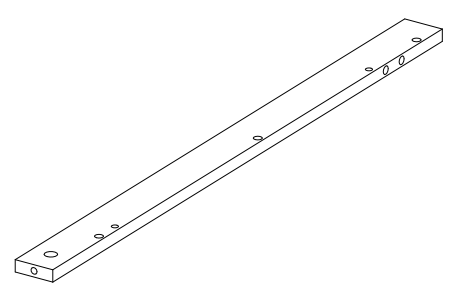

785*50mm

6

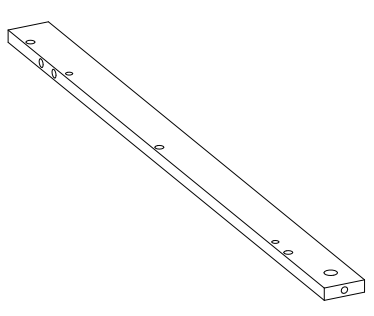

785*50mm

7

X2

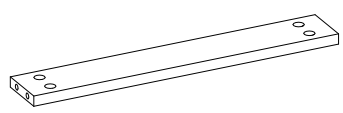

454*70mm

8

X3

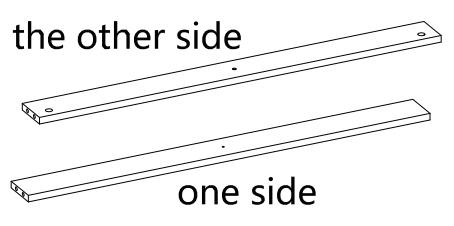

935*80mm

9

X4

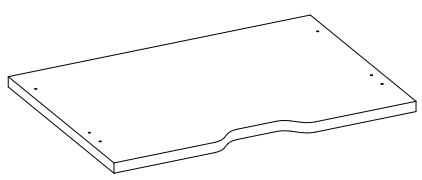

450*315mm

10

X8

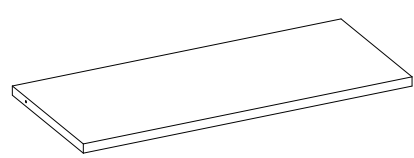

444*142mm

11

X4

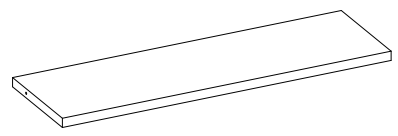

444*85mm

STEP 1

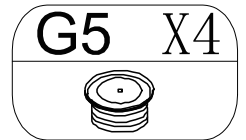
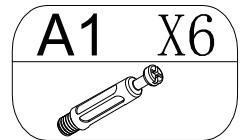
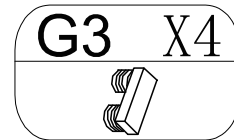
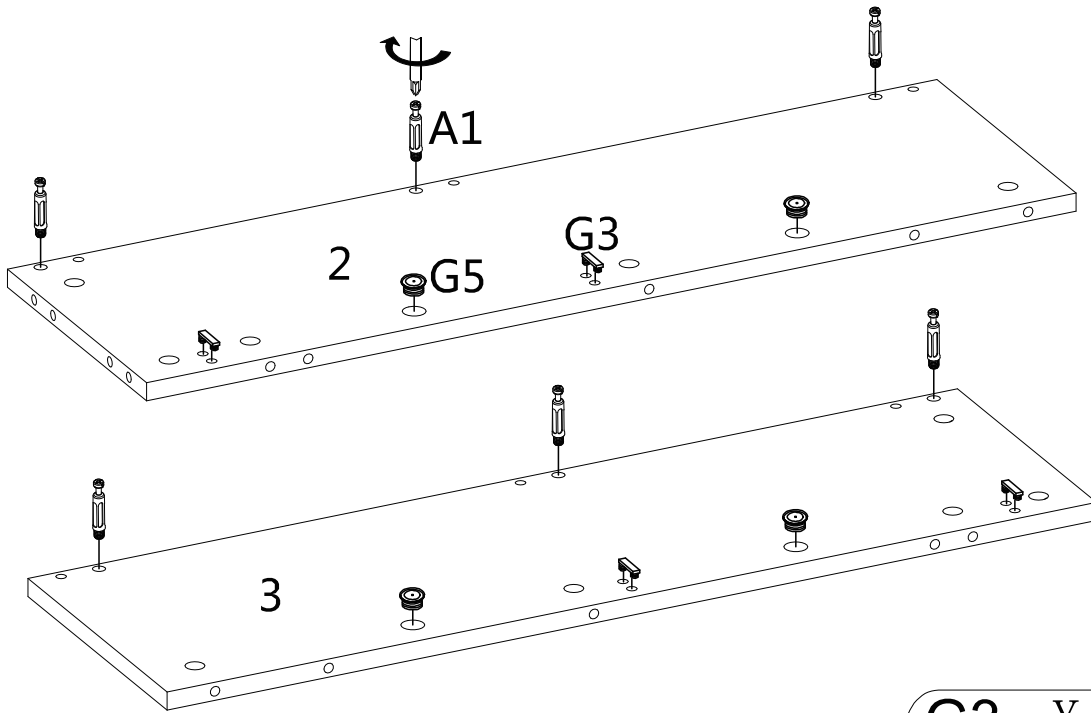
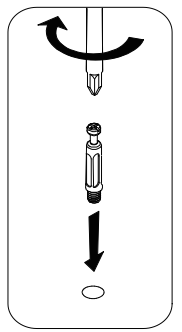
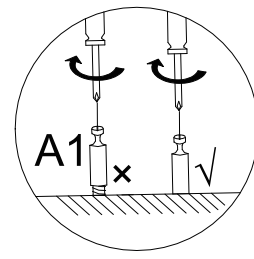

STEP 2

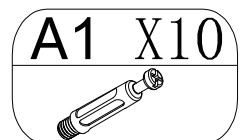
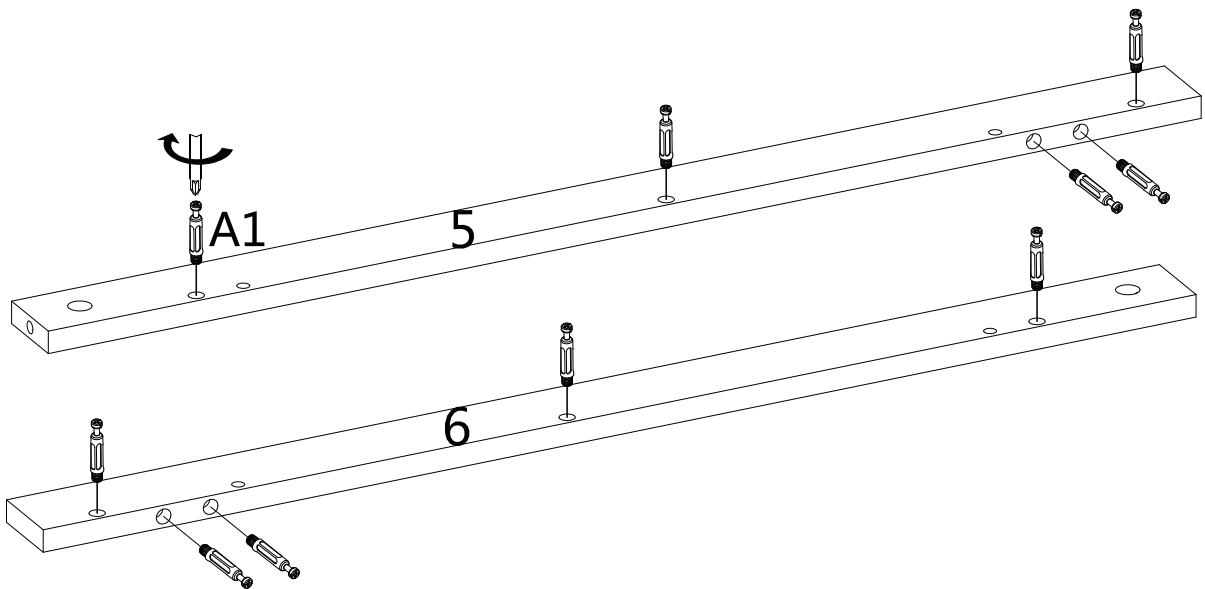

STEP 3

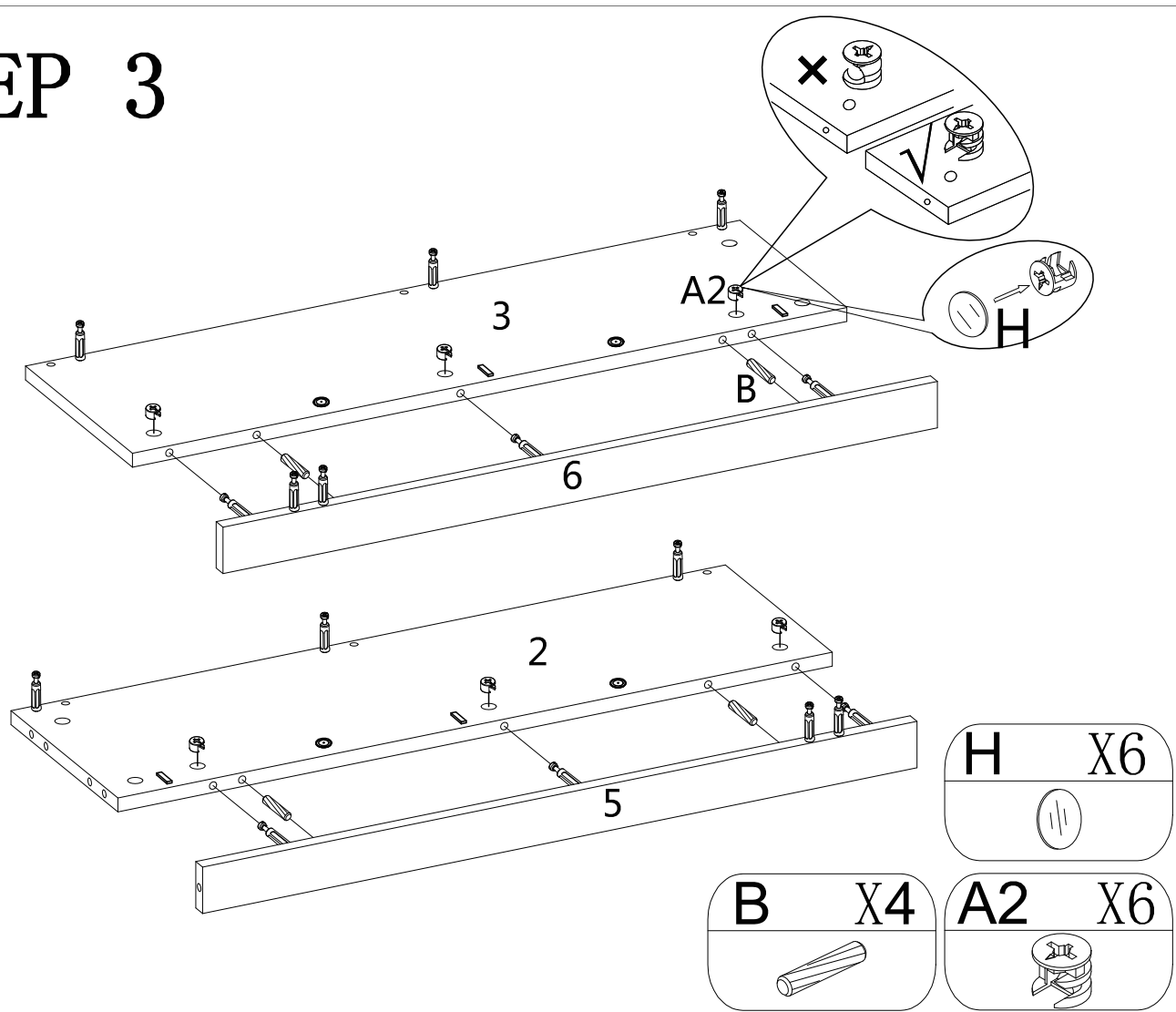

STEP 4

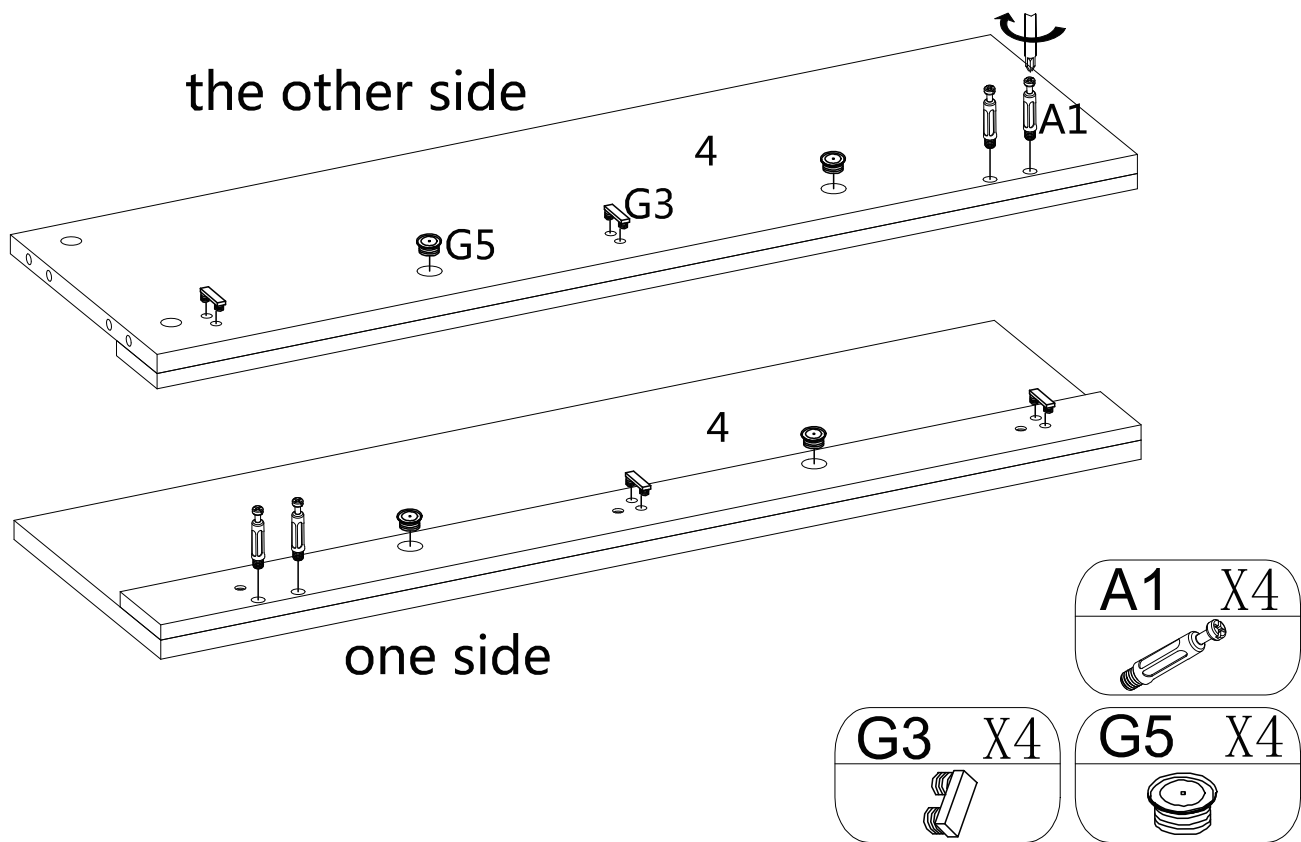

STEP 5

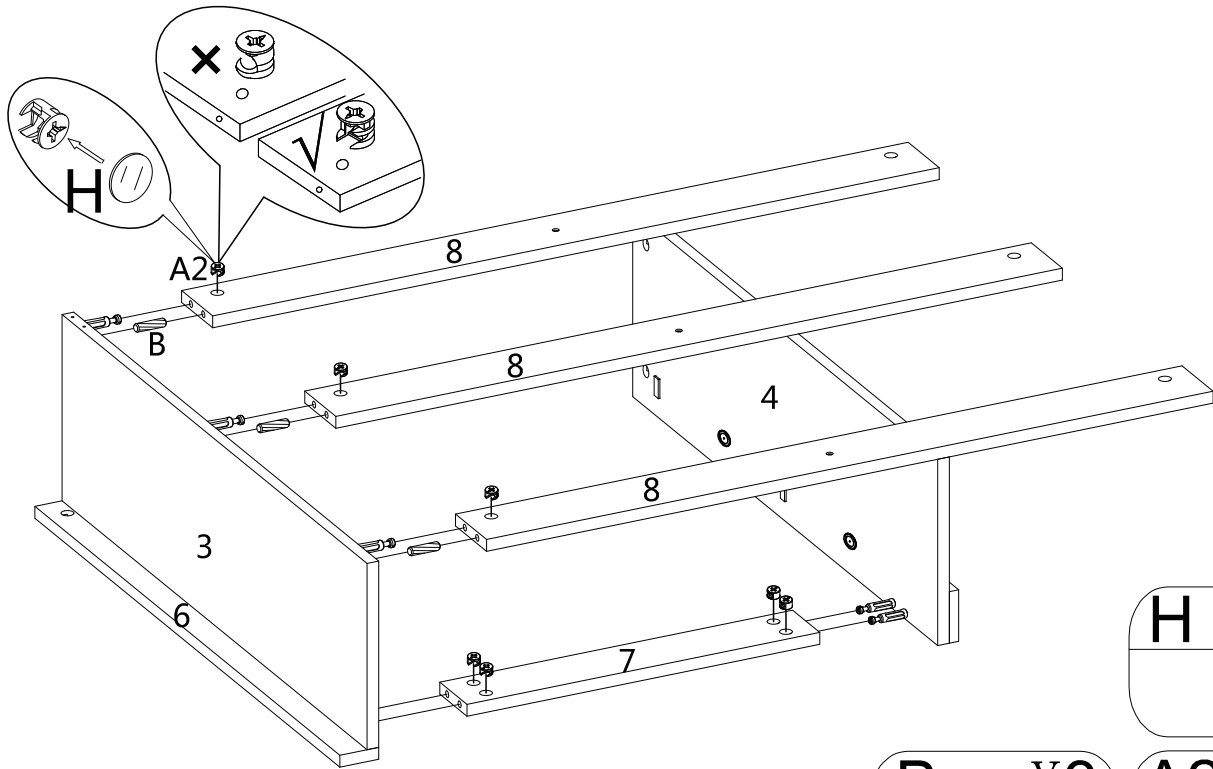

H	X7
B	X3
A2	X7

STEP 6

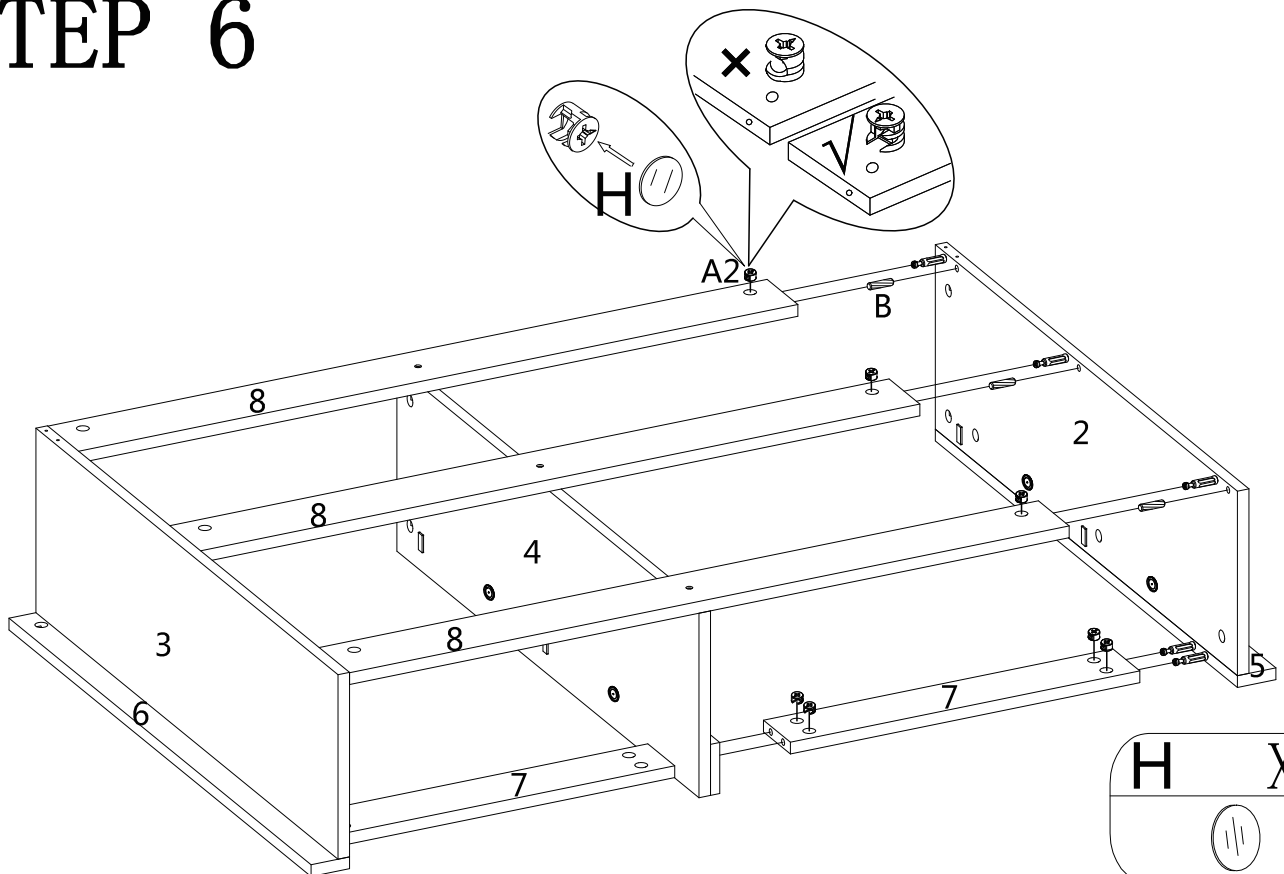

H	X7
B	X3
A2	X7

STEP 7

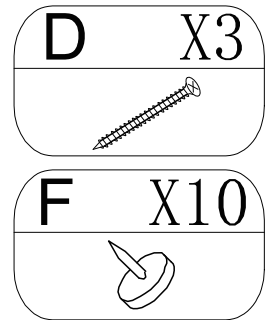
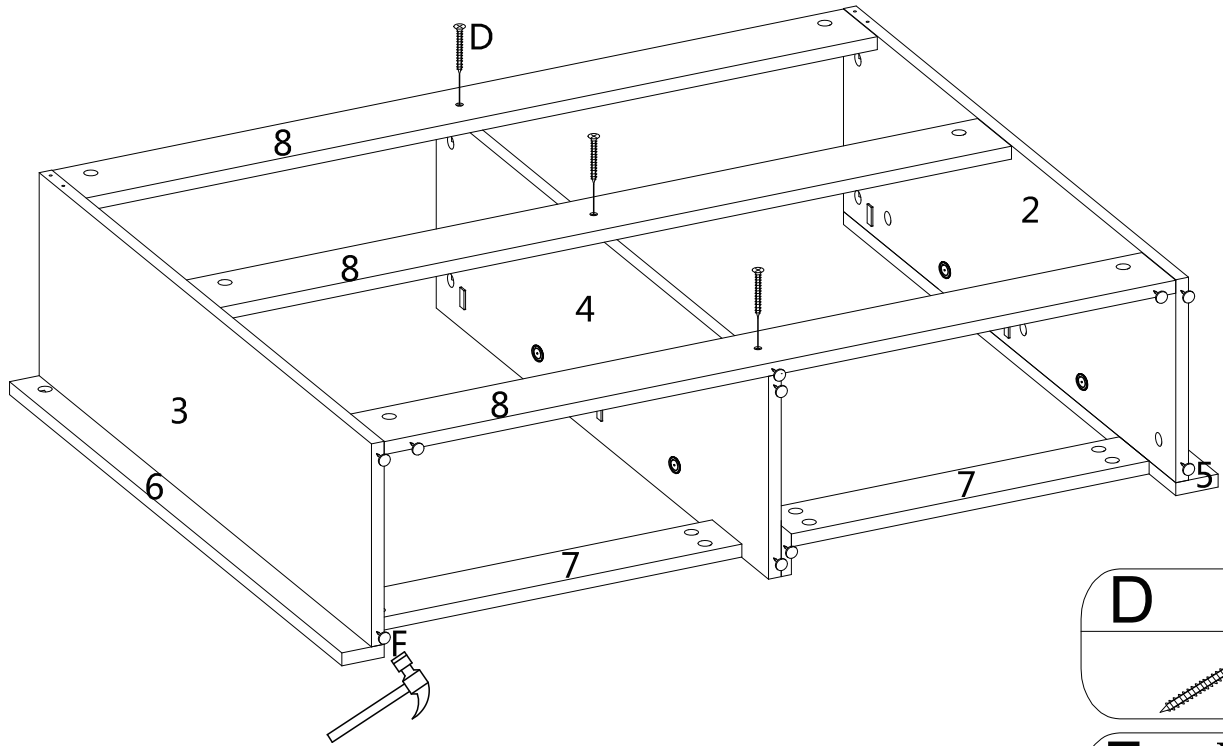

STEP 8

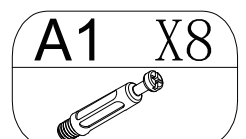
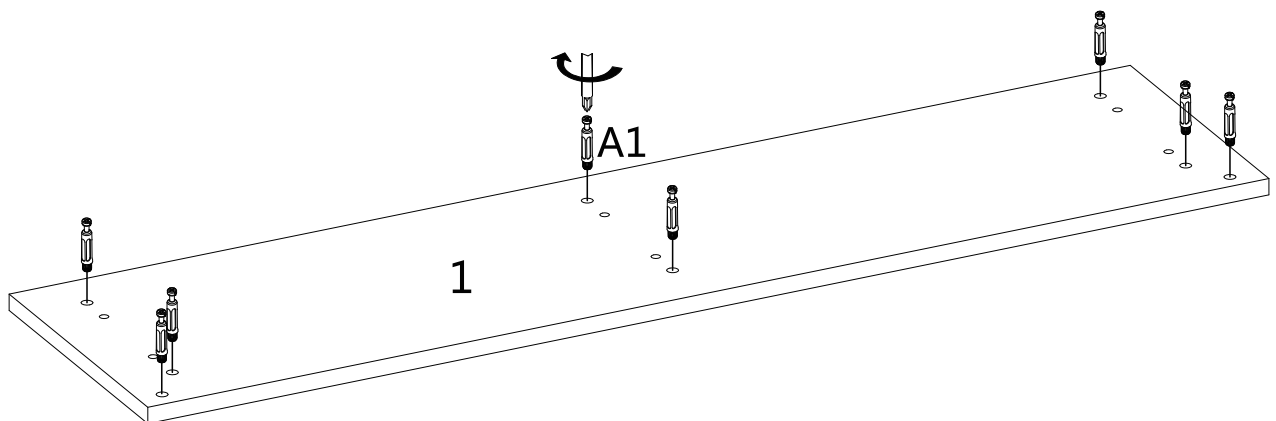
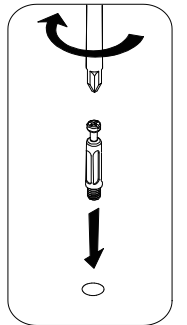
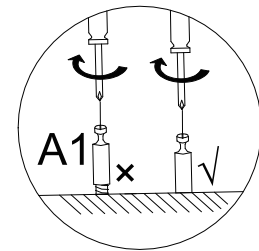

STEP 9

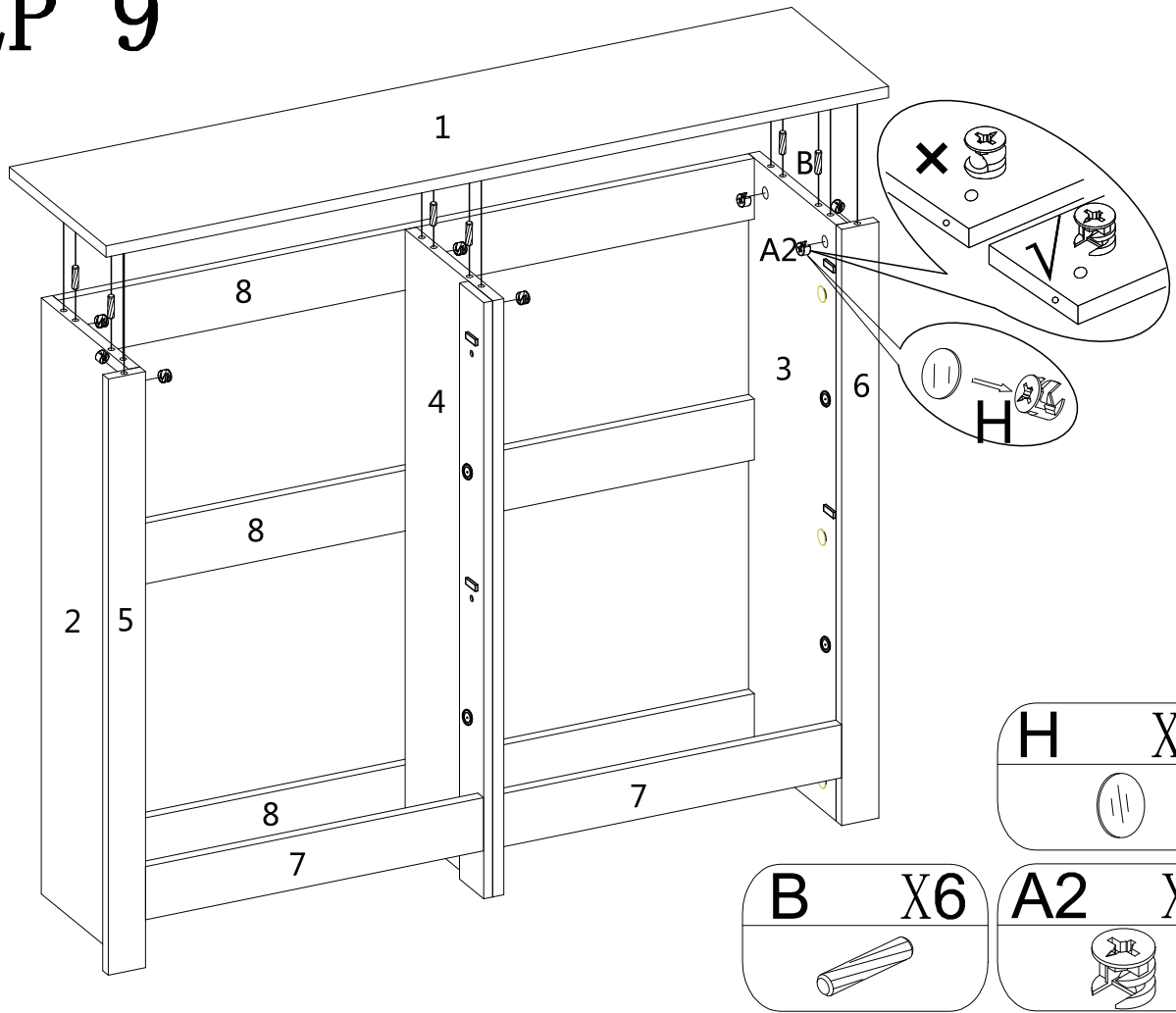

STEP 10

X4

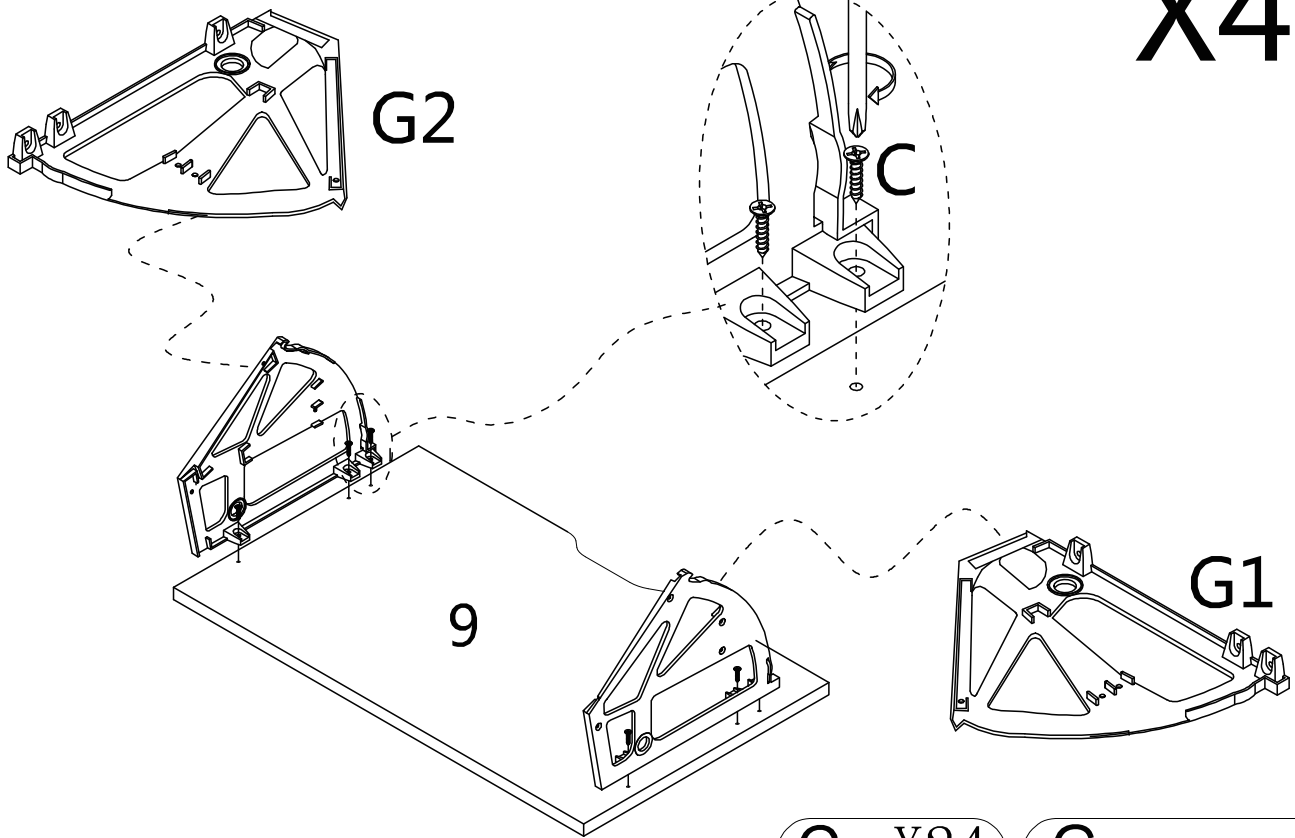

C X24	G X4

STEP 11

X4

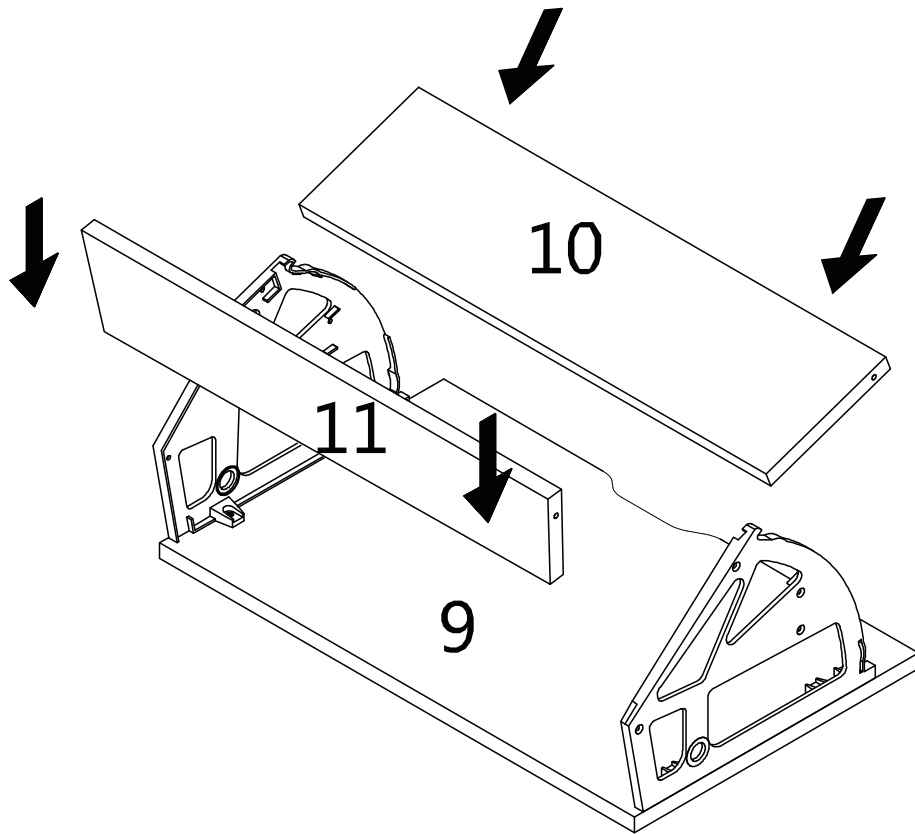

STEP 12

X4

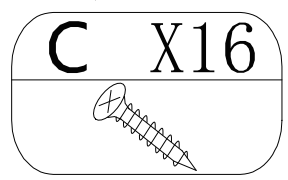
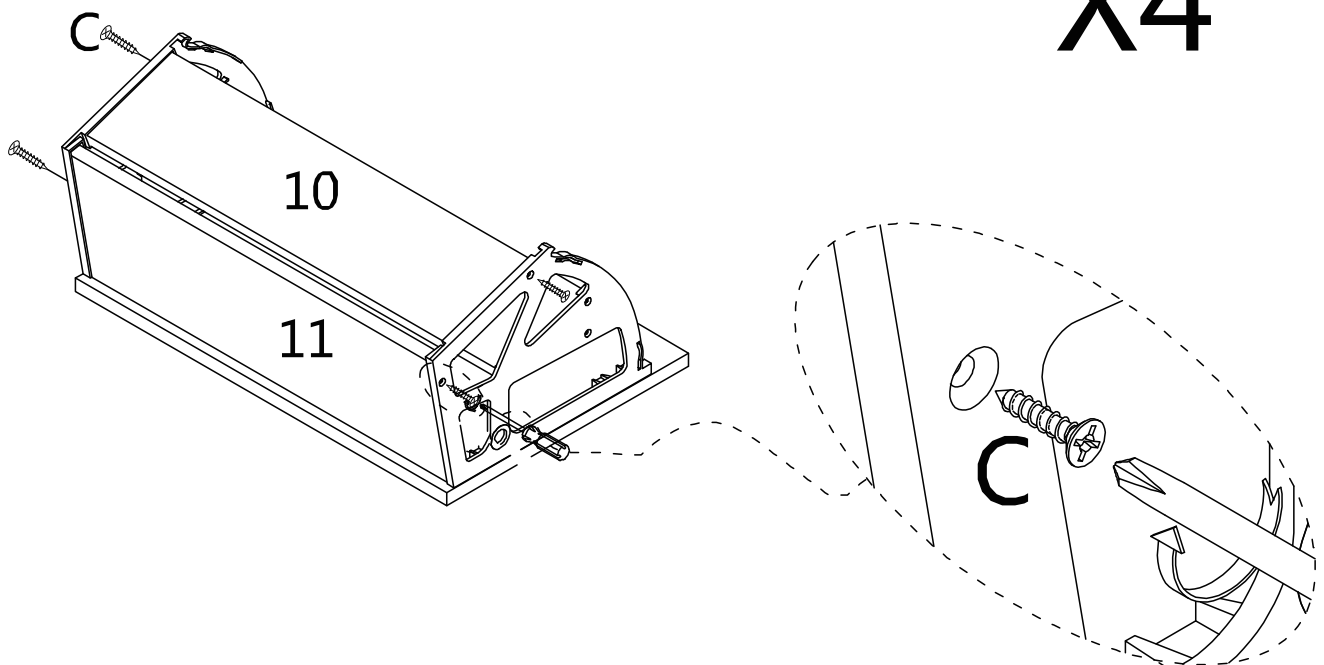

STEP 13

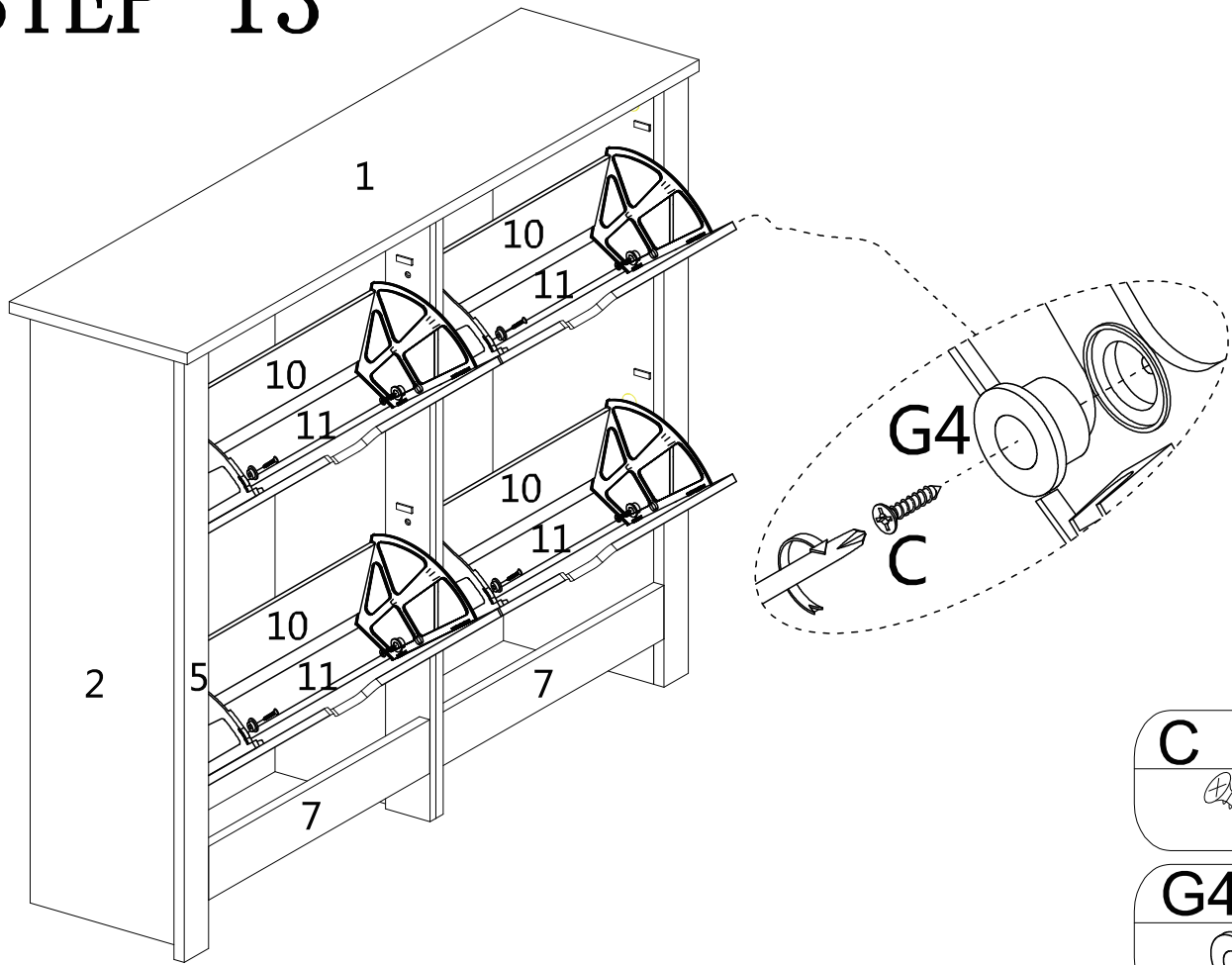

STEP 14

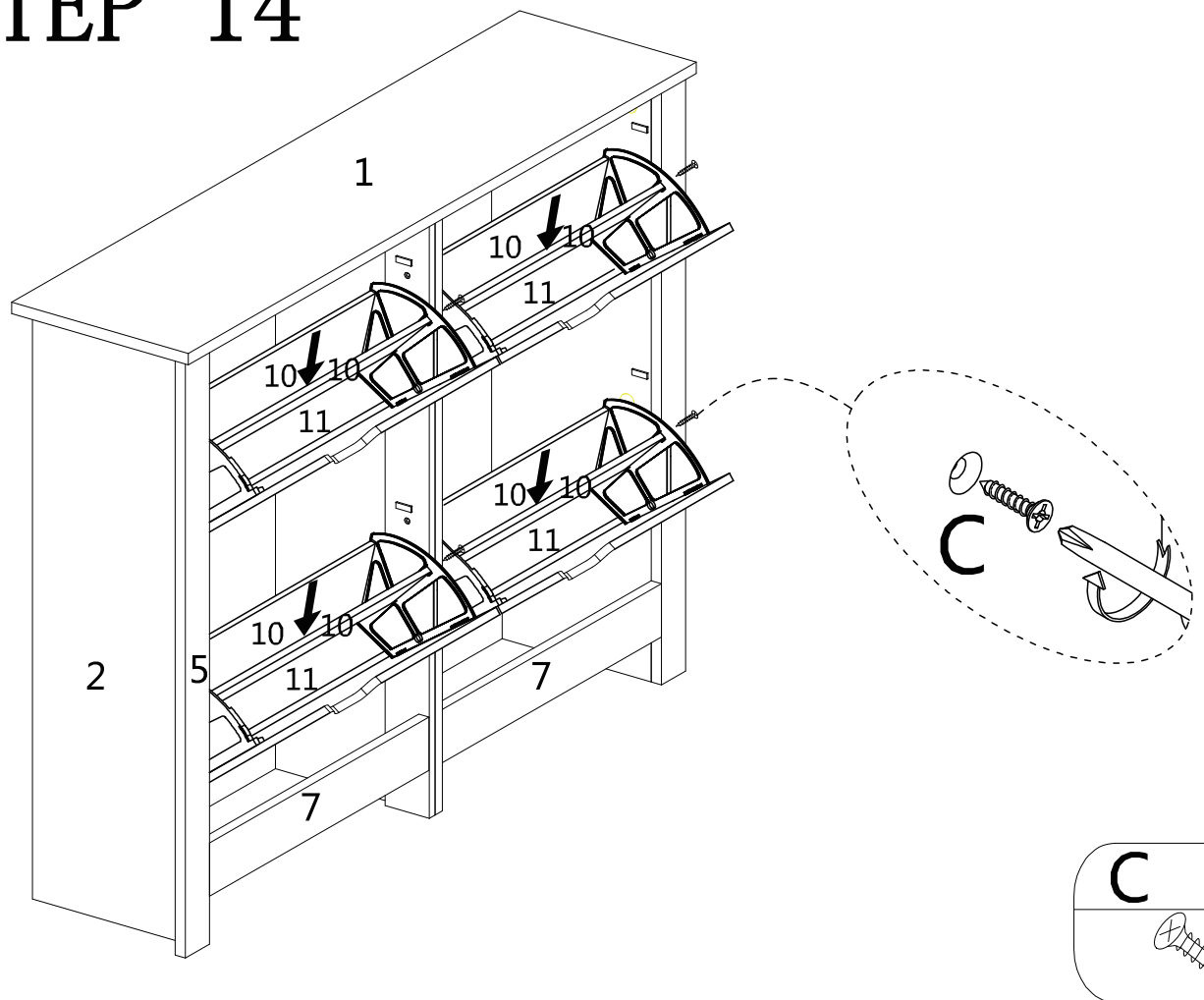

STEP 15

