

# sideboard

Product ID. 7PCF2

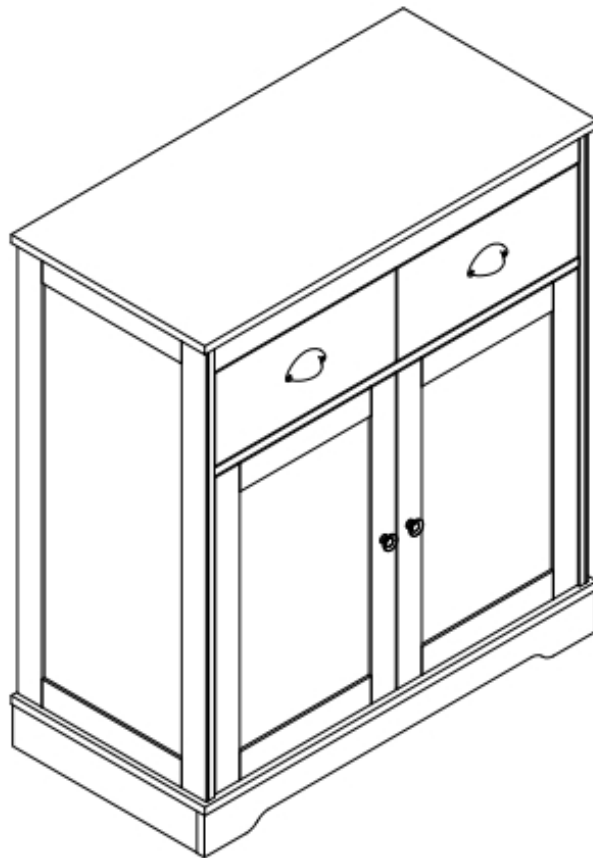

Scan for Support  
[support@garvee.com](mailto:support@garvee.com)









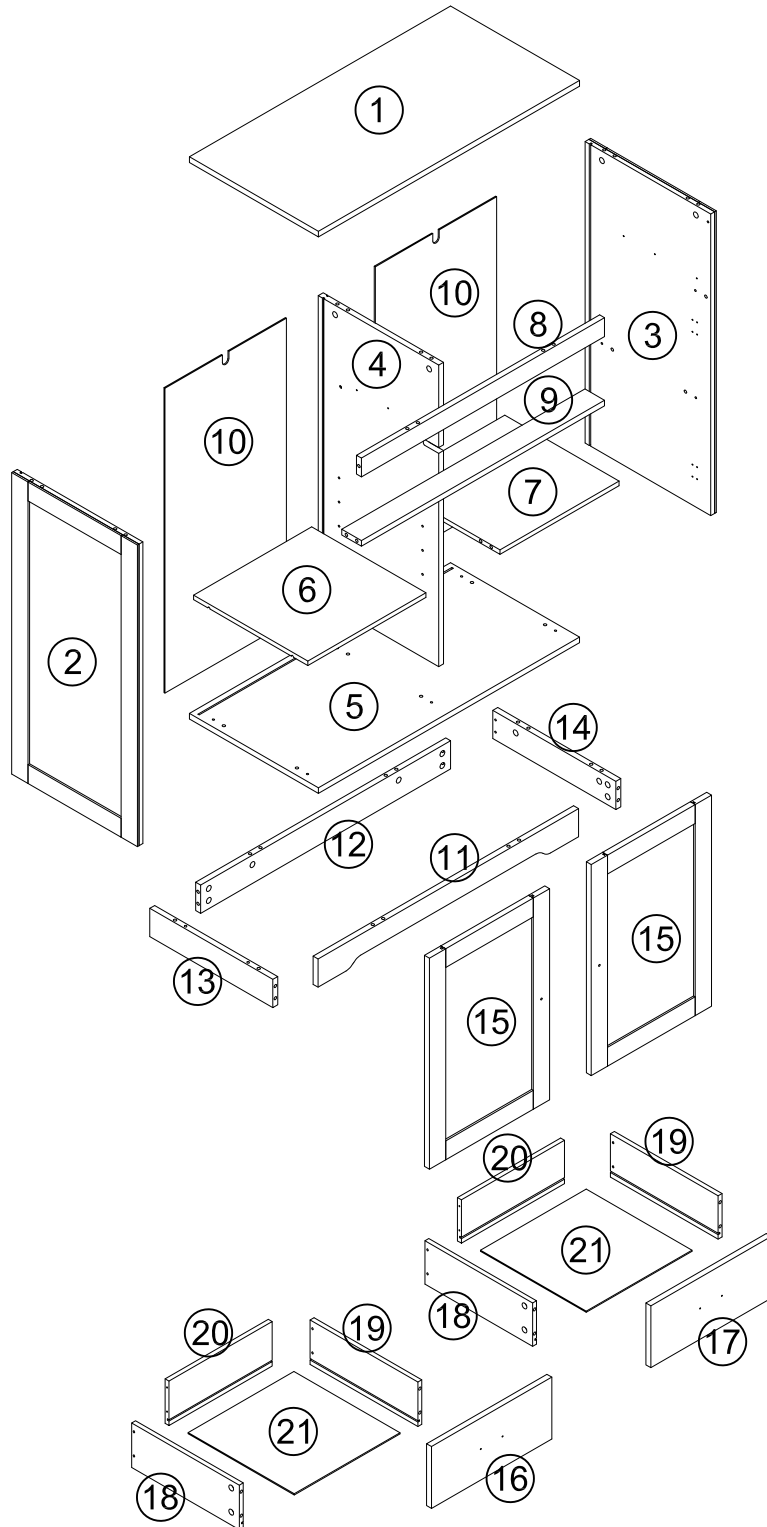







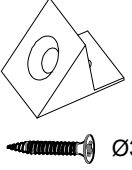
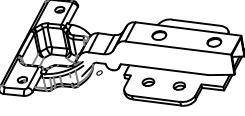

Distributed by  
**GARVEE**.com

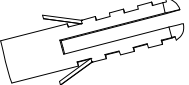
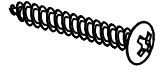
V251126VLKO

Parts List (EN) / Teile Liste (DE)

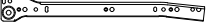



## Parts List (EN) / Teile Liste (DE)

<p><b>A</b></p>  <p>Ø6*32mm    40+2PCS</p>	<p><b>B</b></p>  <p>Ø15*9.5mm    40+2PCS</p>	<p><b>C</b></p>  <p>Ø8*30mm    28+2PCS</p>	<p><b>D</b></p>  <p>Ø3.5*12mm    48+2PCS</p>
<p><b>E</b></p>  <p>Ø4*40mm    14+2PCS</p>	<p><b>F</b></p>  <p>2PCS</p>	<p><b>G</b></p>  <p>M4*20mm    2PCS</p>	<p><b>H</b></p>  <p>Ø3*14mm</p> <p>8+1PCS</p>
<p><b>I</b></p>  <p>4PCS</p>	<p><b>J</b></p>  <p>73*24*15mm    2PCS</p>	<p><b>K</b></p>  <p>2PCS</p>	<p><b>L</b></p>  <p>Ø4*32mm    2PCS</p>
<p><b>M</b></p>  <p>Ø4*12mm    2PCS</p>	<p><b>N</b></p>  <p>4PCS</p>	<p><b>O</b></p>  <p>Ø3*14mm    4PCS</p>	<p><b>P</b></p>  <p>2PCS</p>
<p><b>CL</b></p>  <p>300mm    2PCS</p>	<p><b>CR</b></p>  <p>300mm    2PCS</p>	<p><b>DL</b></p>  <p>300mm    2PCS</p>	<p><b>DR</b></p>  <p>300mm    2PCS</p>

# Assembly Steps (EN) / Montageschritte (DE)

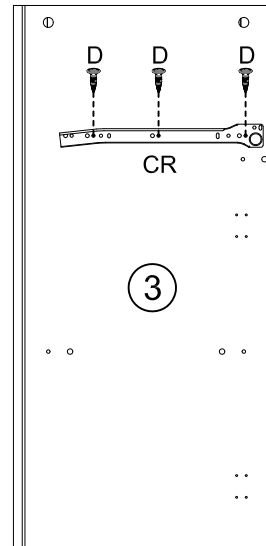
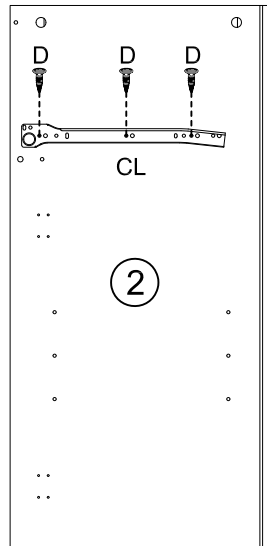
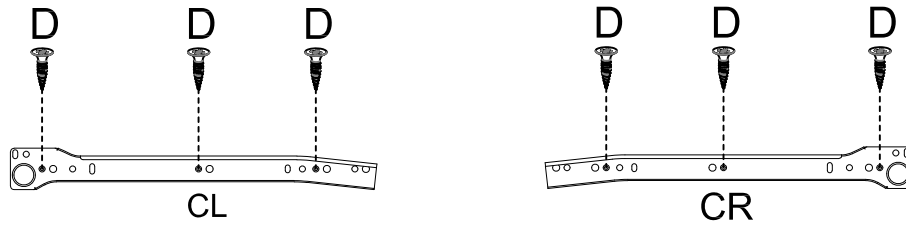

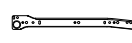
## Step:1

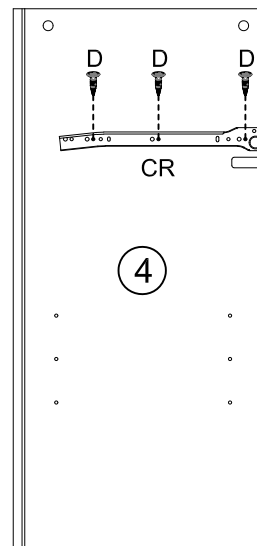
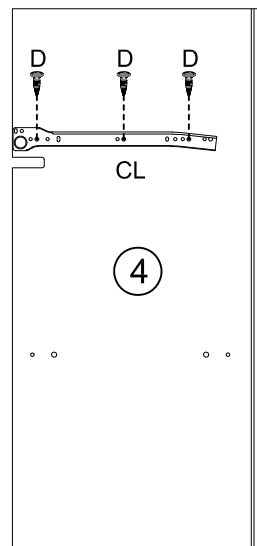
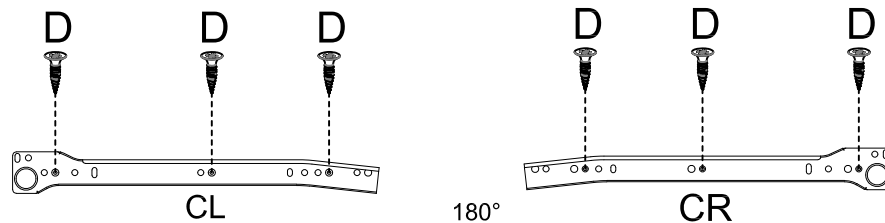

	CL x 1PCS
	CR x 1PCS
	D x 6PCS

## Step:2

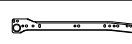
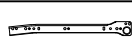

	CL x 1PCS
	CR x 1PCS
	D x 6PCS

# Assembly Steps (EN) / Montageschritte (DE)

## Step:3

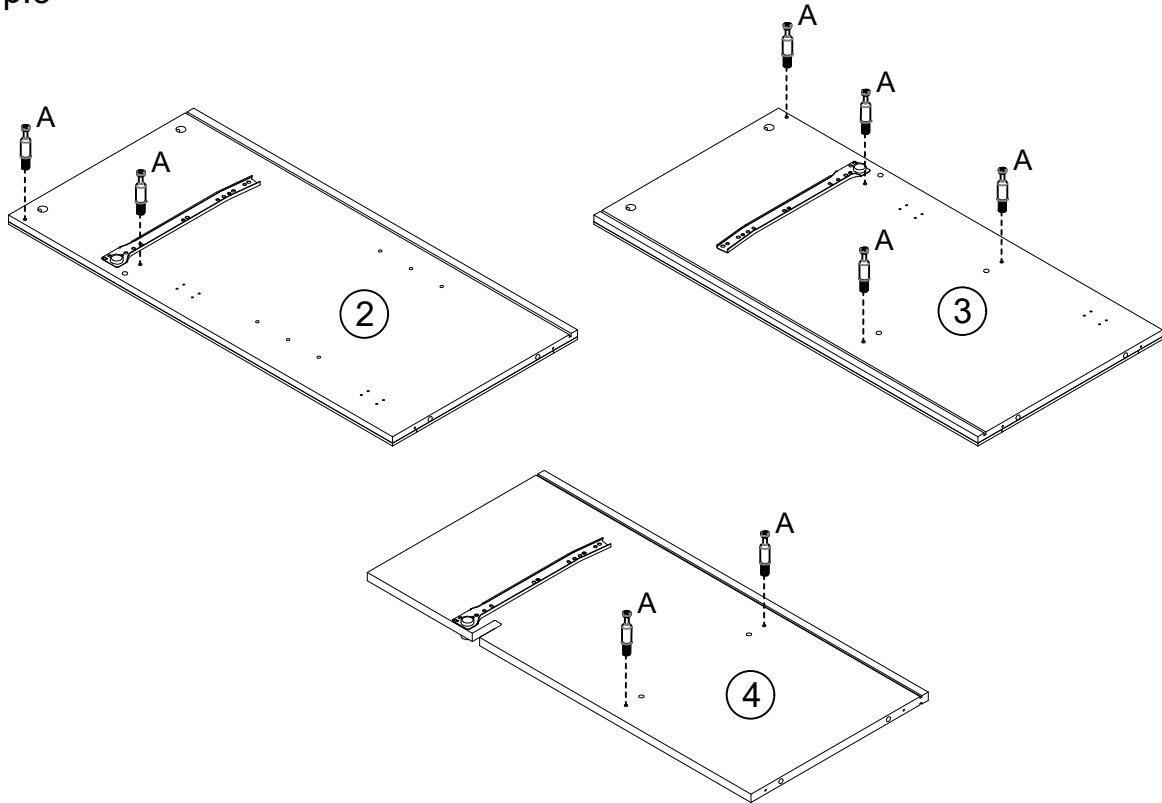

A x 8PCS

## Step:4

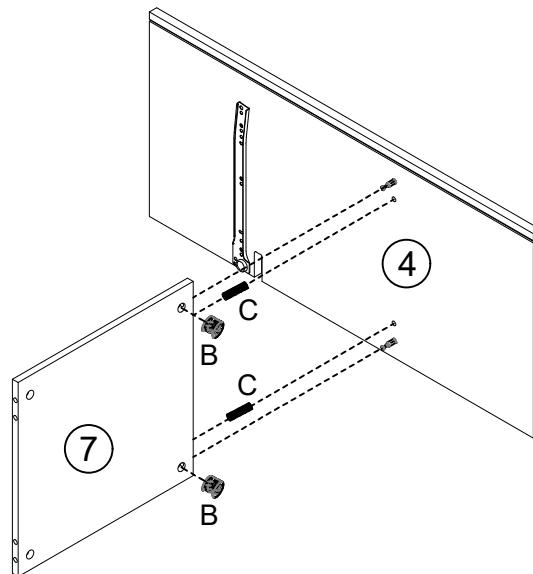

B x 2PCS



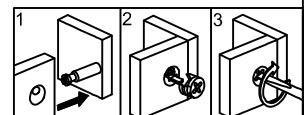

C x 2PCS

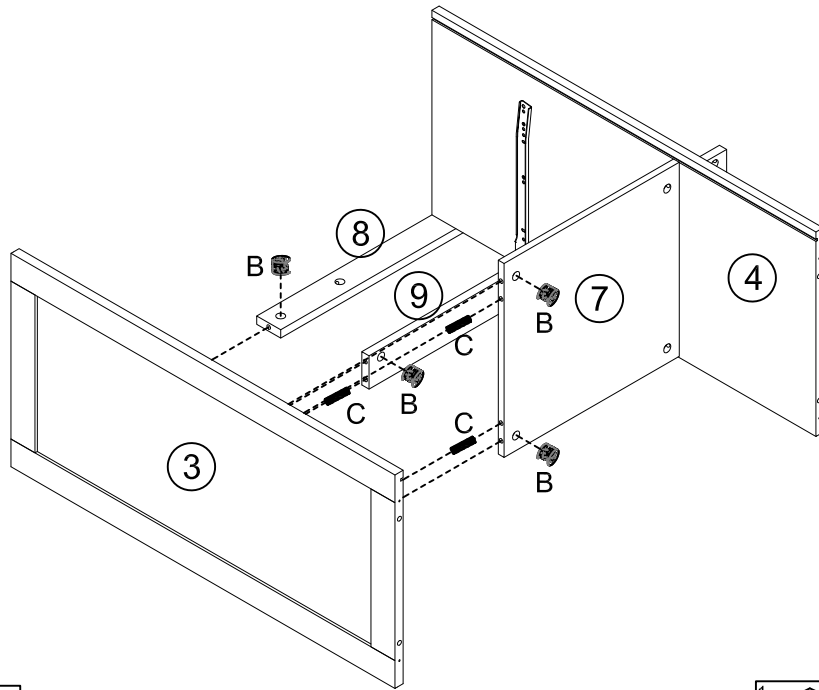

# Assembly Steps (EN) / Montageschritte (DE)

## Step:5



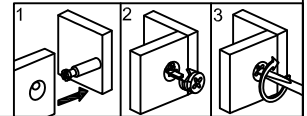

	B x 4PCS
	C x 3PCS

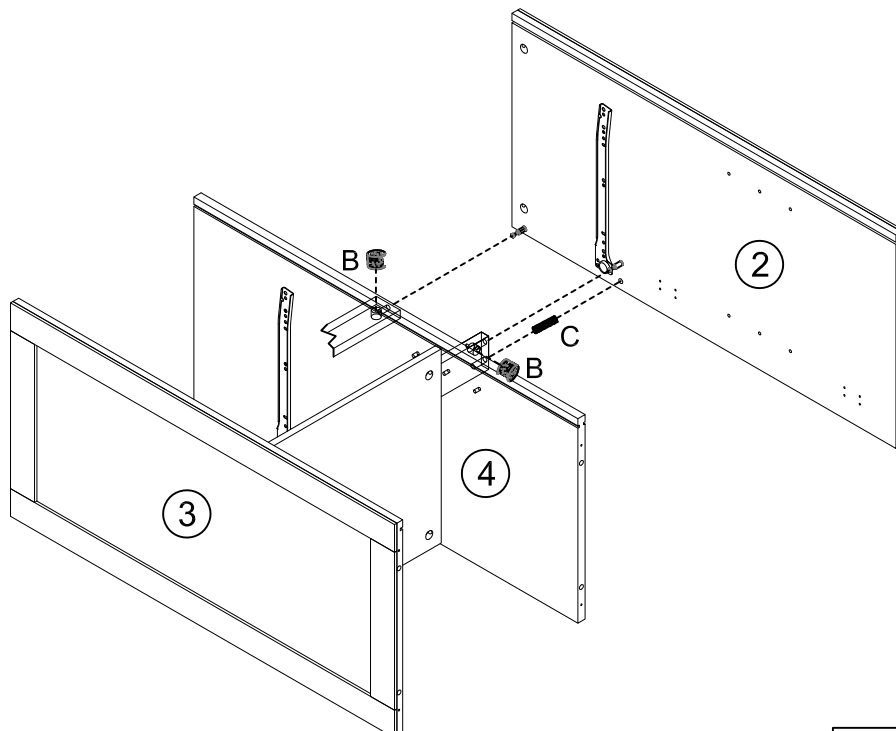

## Step:6





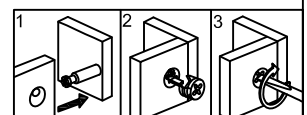

	B x 2PCS
	C x 1PCS

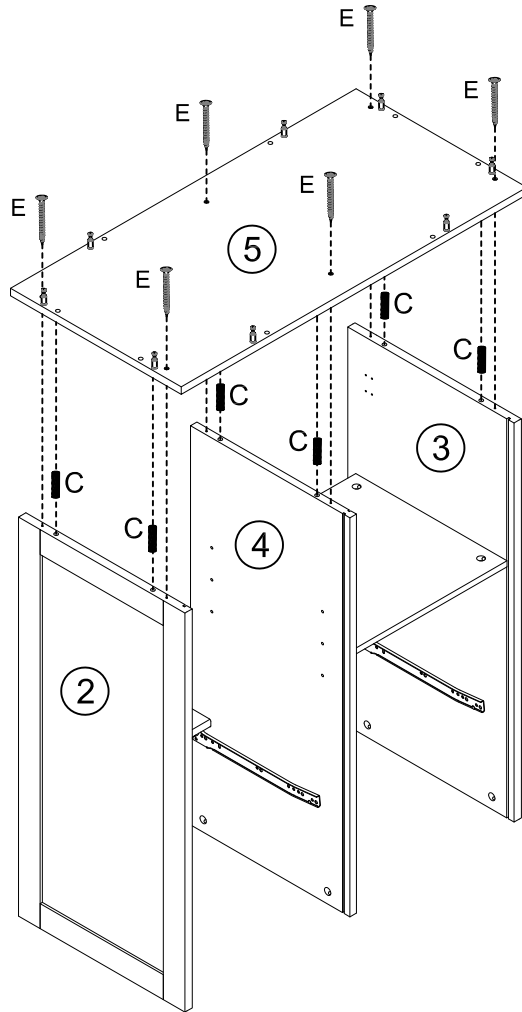
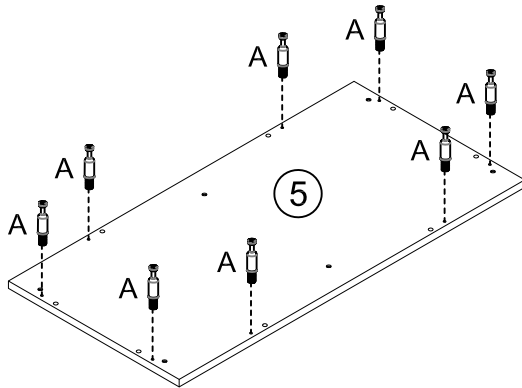

# Assembly Steps (EN) / Montageschritte (DE)



## Step:7

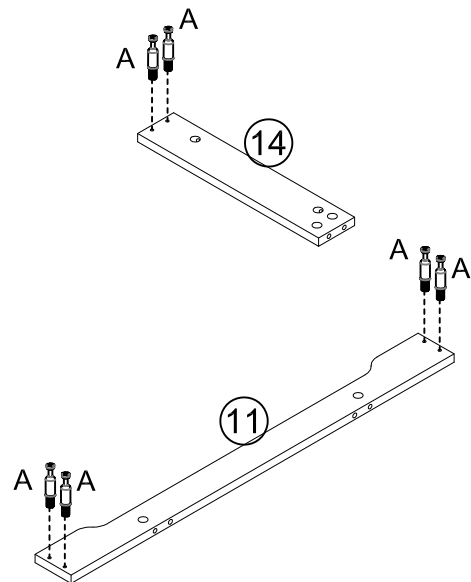
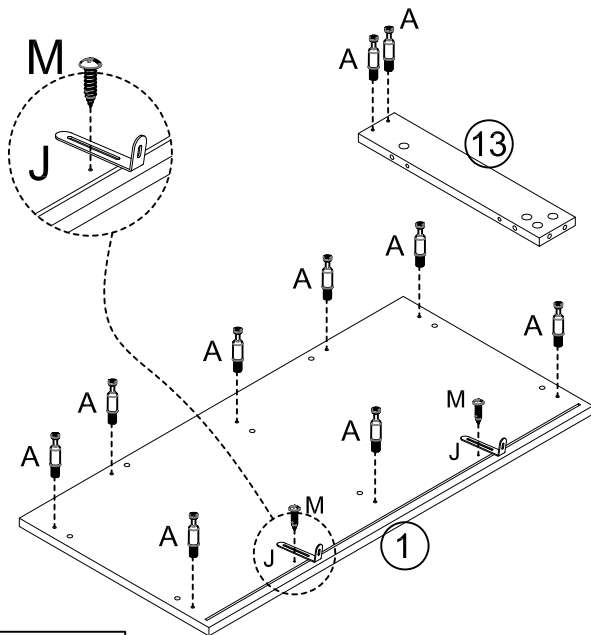

	A x 8PCS
	C x 6PCS
	E x 6PCS

## Step:8



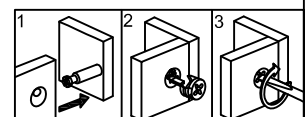

	A x 16PCS
	M x 2PCS
	J x 2PCS

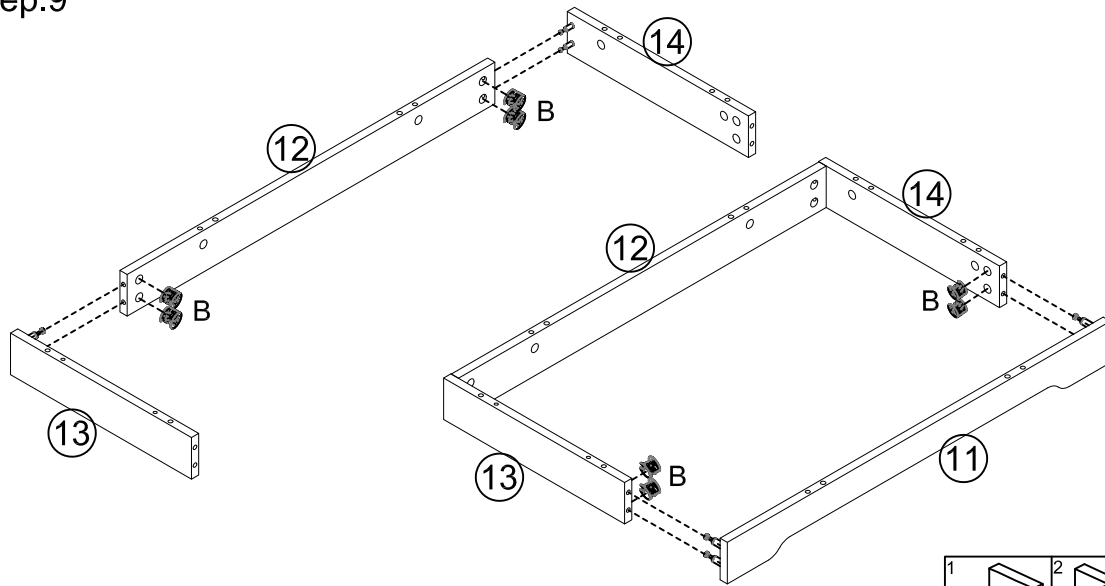

# Assembly Steps (EN) / Montageschritte (DE)

Step:9



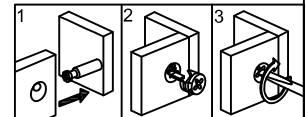

	B x 8PCS
---	----------

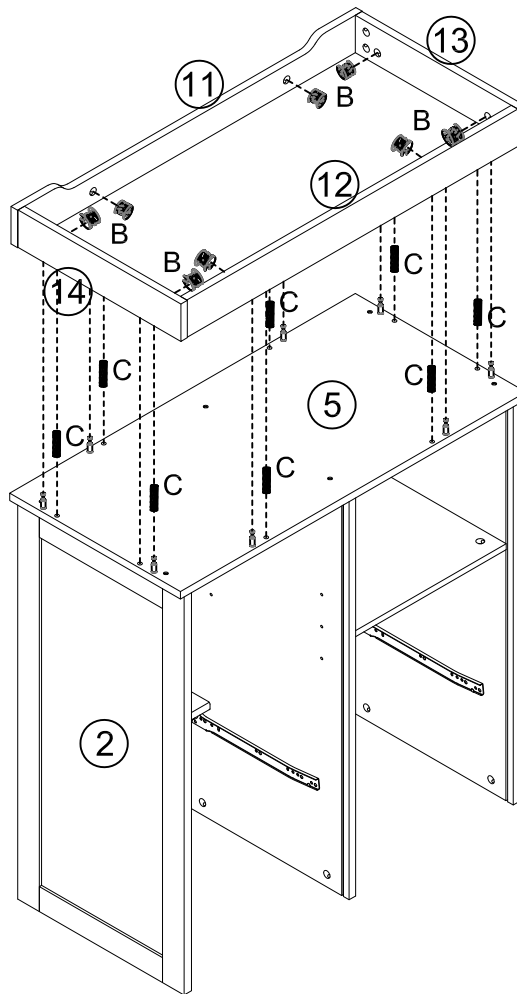

Step:10



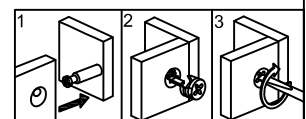

	B x 8PCS
	C x 8PCS

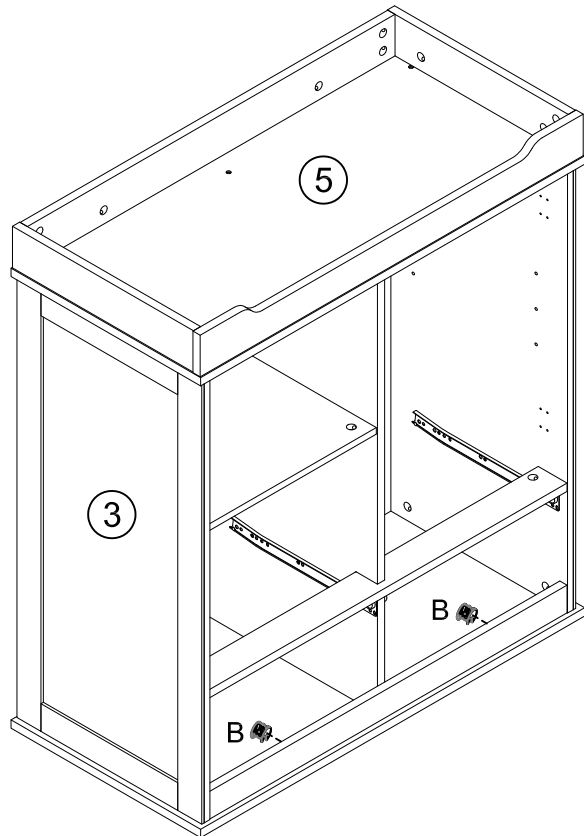
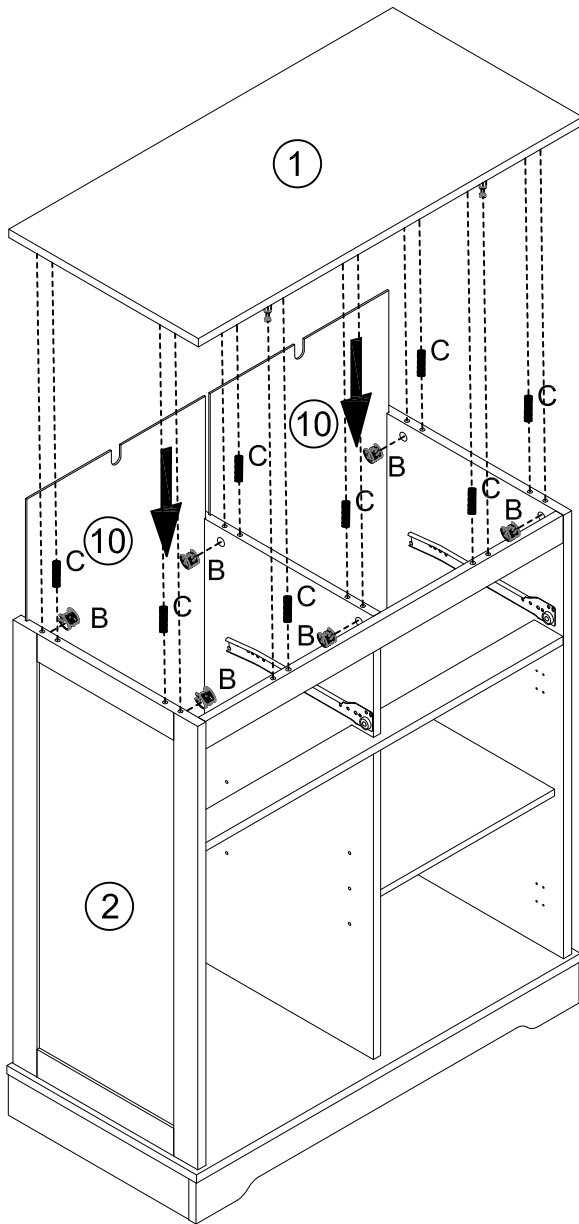

# Assembly Steps (EN) / Montageschritte (DE)

Step:11



	B x 8PCS
	C x 8PCS

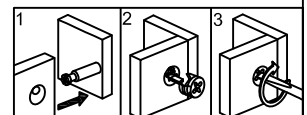

# Assembly Steps (EN) / Montageschritte (DE)

Step:12

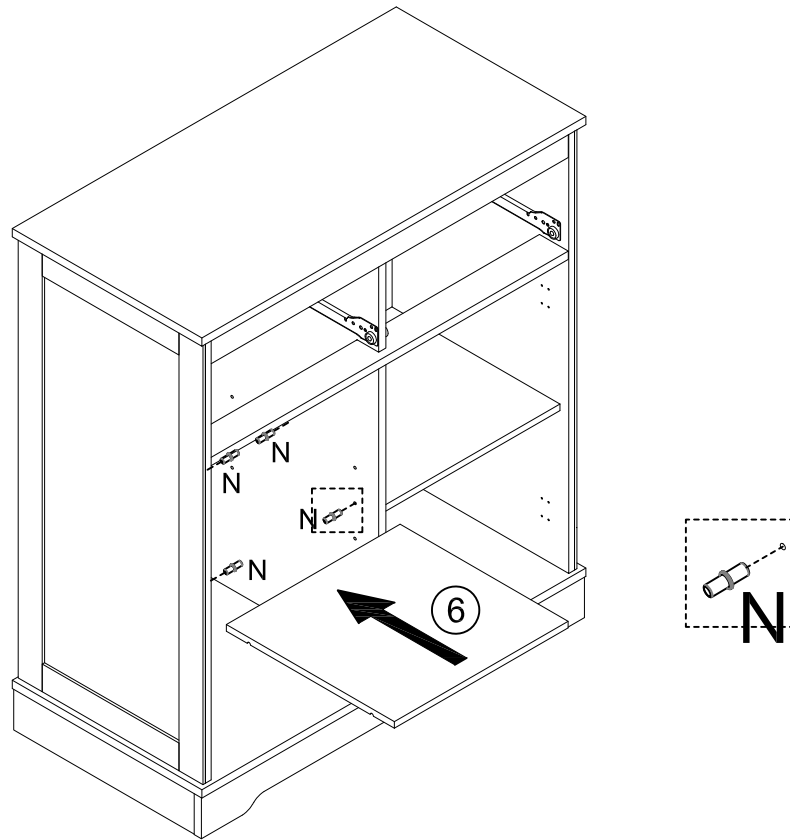

N x 4PCS

Step:13

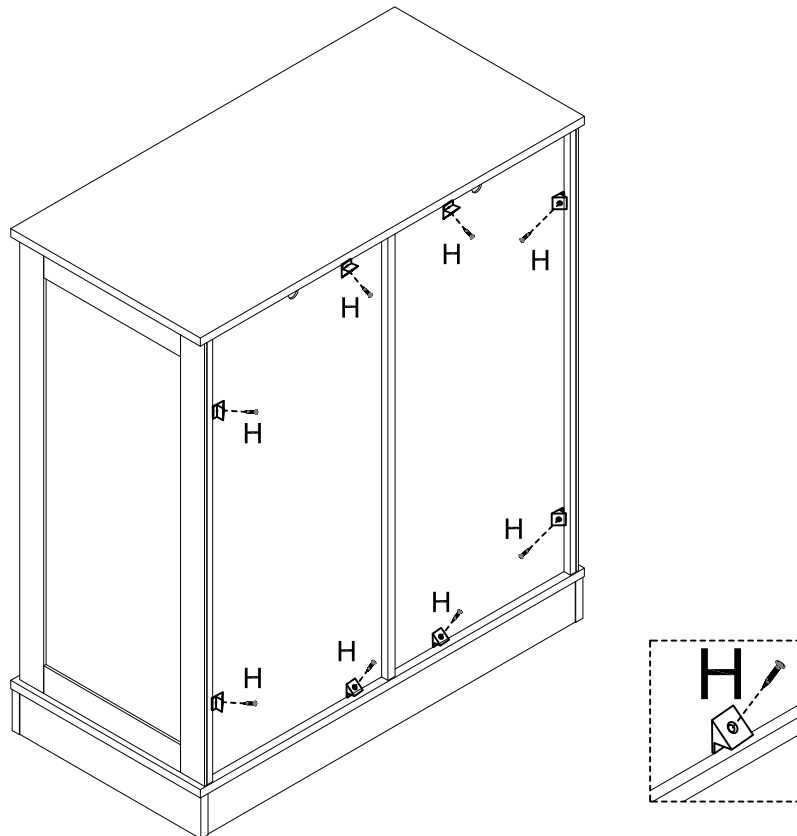

H x 8PCS



H x 8PCS

# Assembly Steps (EN) / Montageschritte (DE)

Step:14 Drill a hole on the wall at the required position for

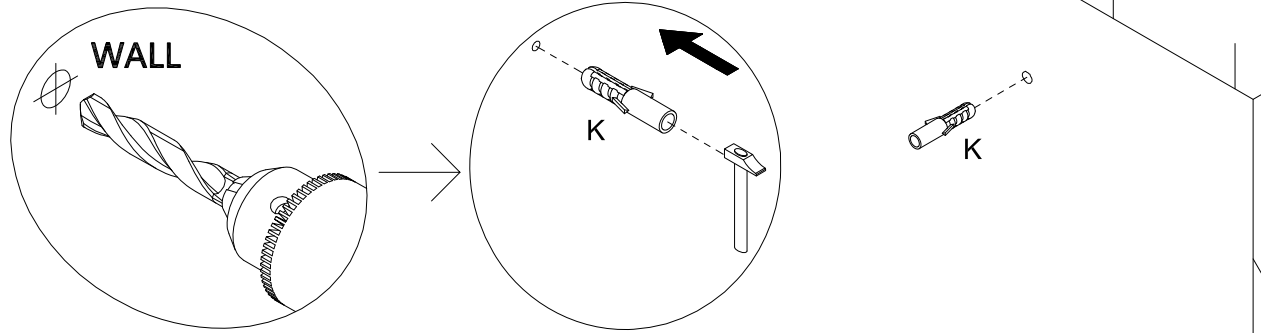

Kx 2PCS

Step:15

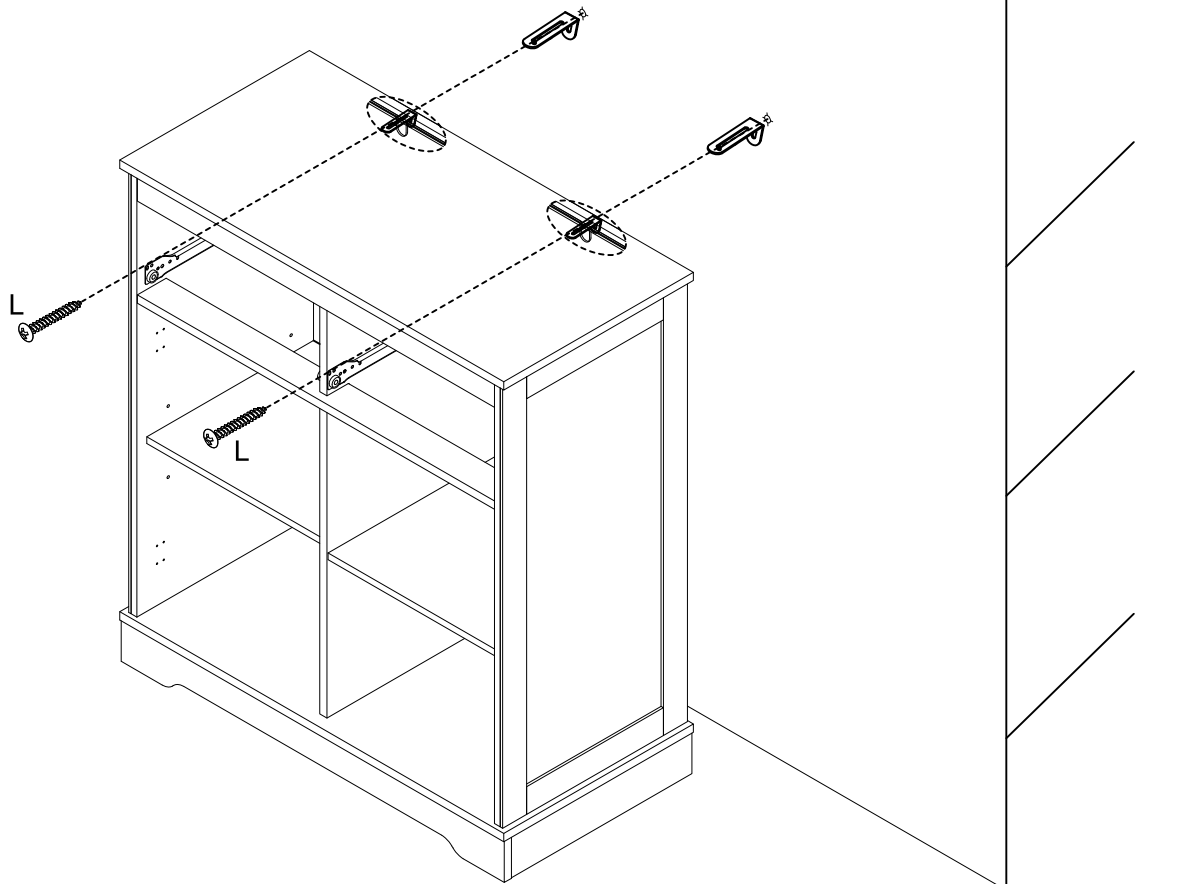

L x 2PCS

# Assembly Steps (EN) / Montageschritte (DE)

Step:16

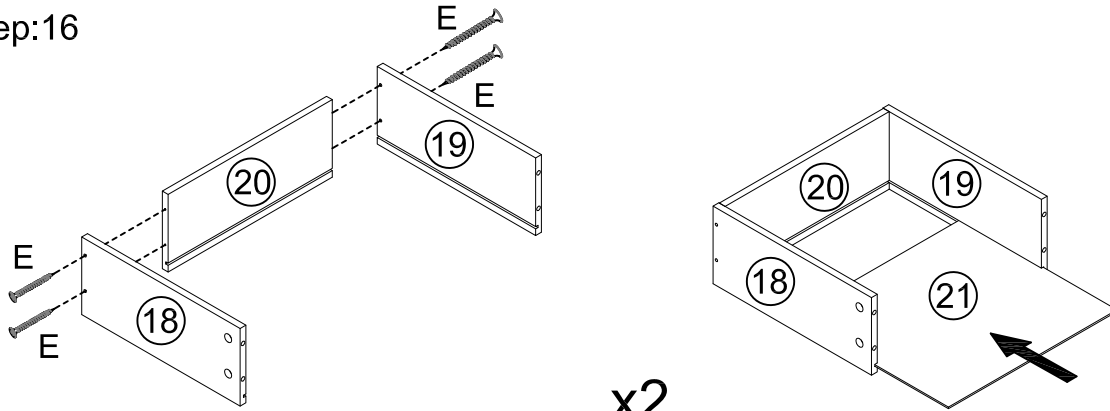



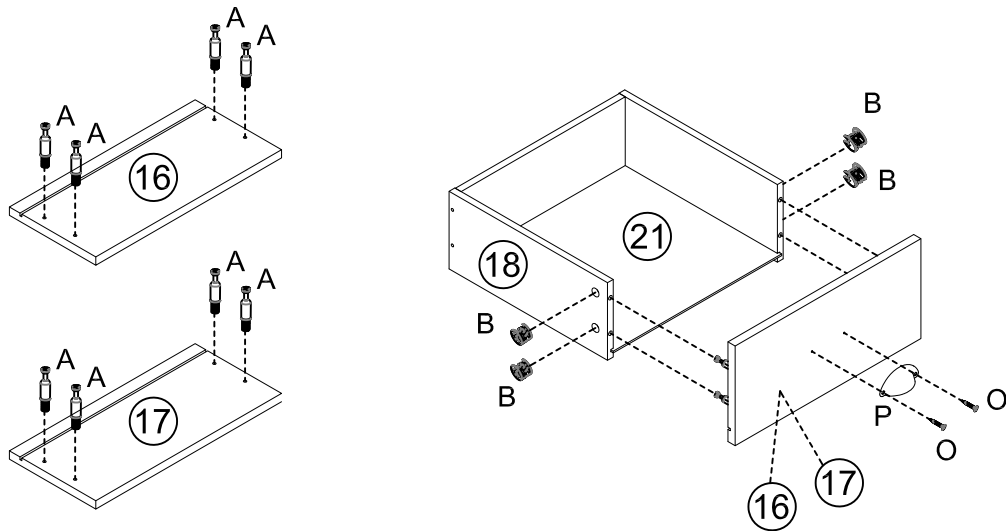

x2

	E x 8PCS
---	----------

Step:17



x2

	A x 8PCS		O x 4PCS
	B x 8PCS		P x 2PCS

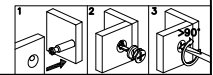

Step:18

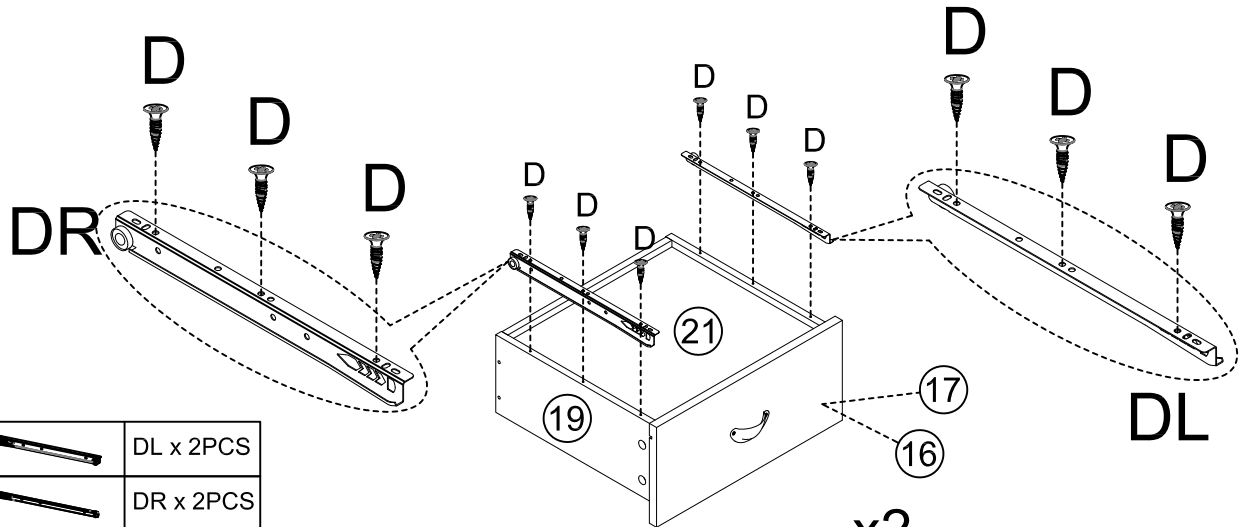

x2

	DL x 2PCS
	DR x 2PCS
	D x 12PCS

# Assembly Steps (EN) / Montageschritte (DE)



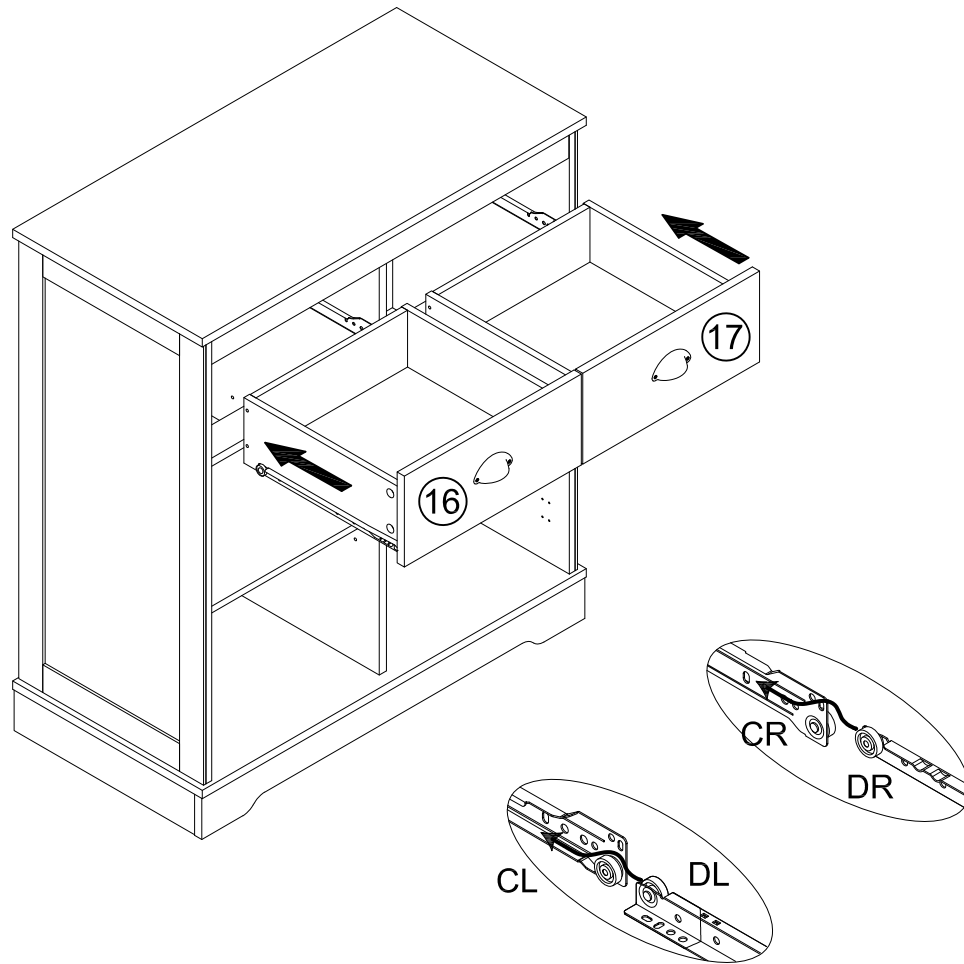

Step:19

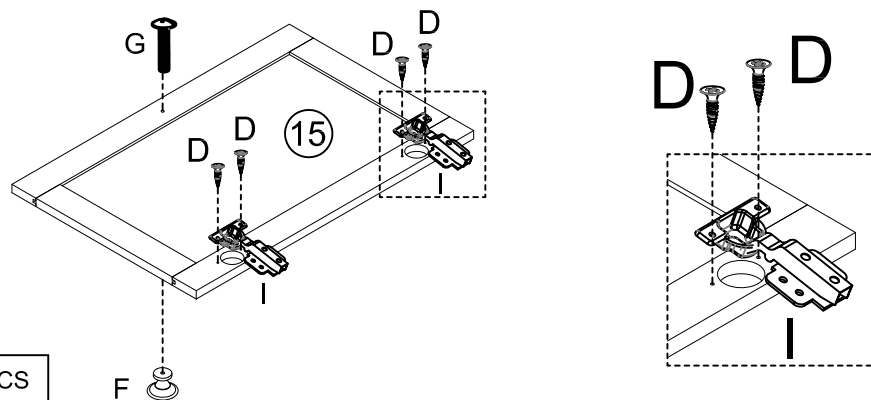

Step:20



x2

	D x 8PCS
	F x 2PCS
	G x 2PCS
	I x 4PCS

Step:21

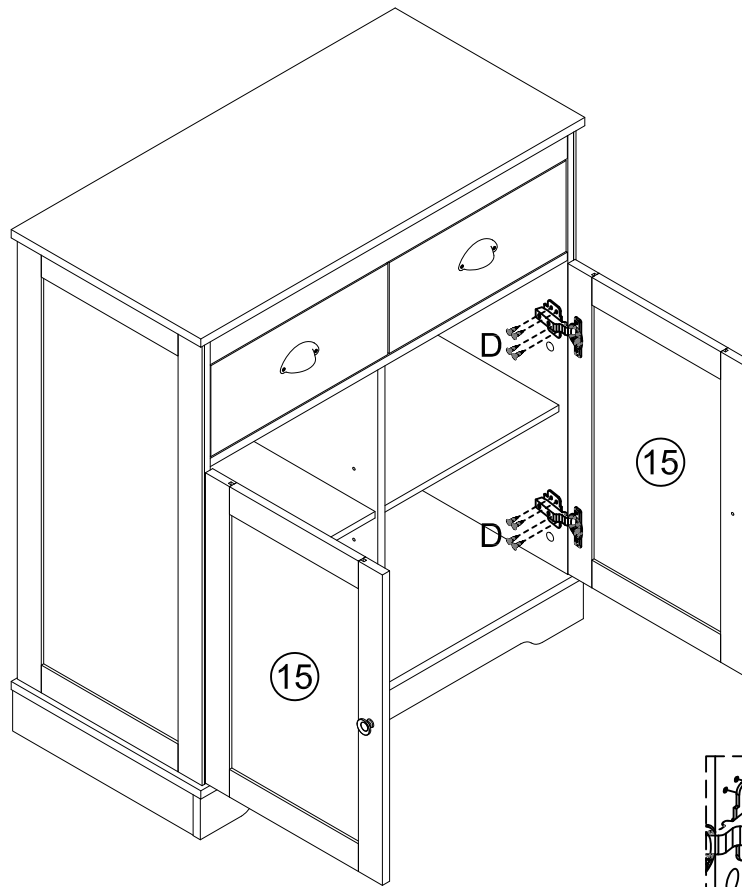

Installation method of hinge

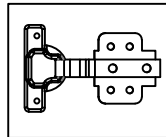

Tighten the lead holes

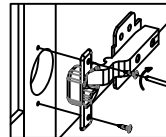

Align at the lead hole and don't twist it tightly

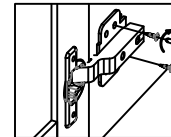

Adjustment of front and back

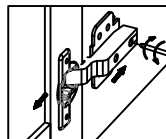

Adjustment of left and right

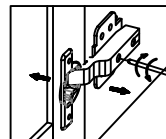

Tighten after proper adjustment up and down

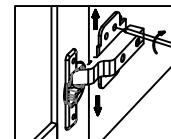

D x 16PCS