

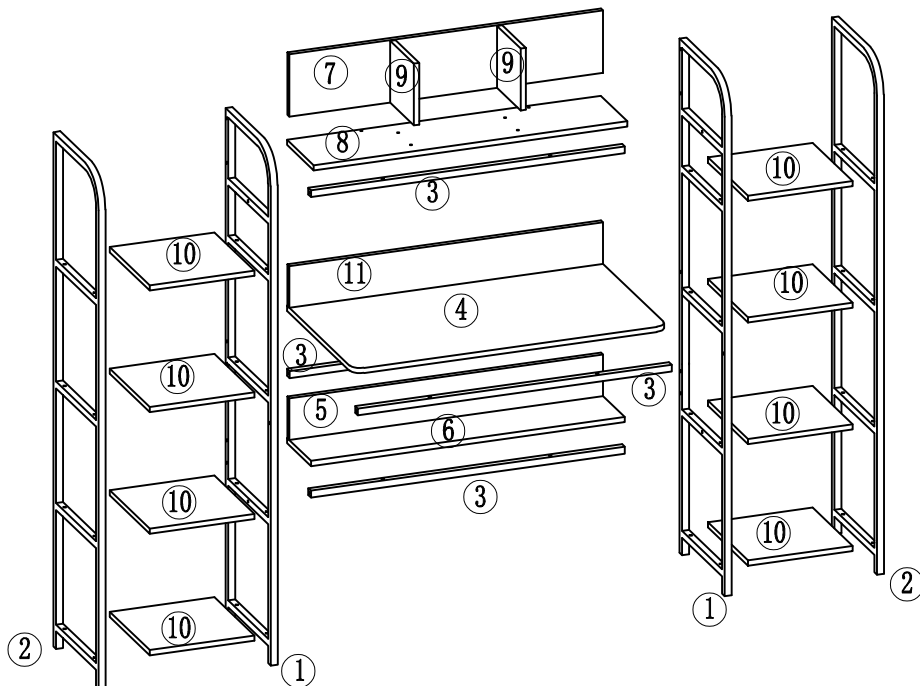

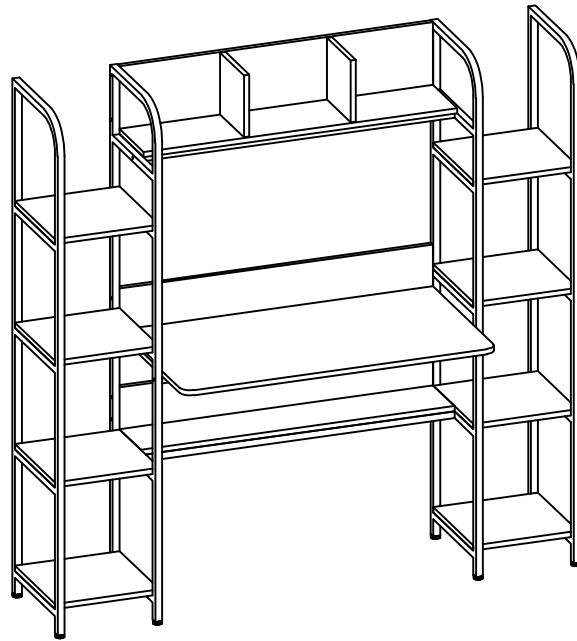

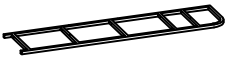









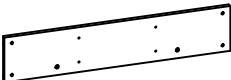



ASSEMBLY INSTRUCTIONS

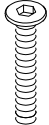

Part List

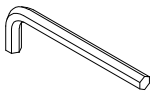
				
① x2Pcs	② x2Pcs	③ x4Pcs	④ x1Pc	⑤ x1Pc
				
⑥ x1Pc	⑦ x1Pc	⑧ x1Pc	⑨ x2Pcs	⑩ x8Pcs
				
⑪ x1Pc				

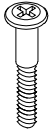
Hardware List

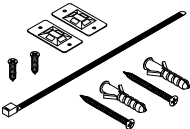
				
Ax6Pcs	Bx6Pcs	M6x50 Cx12Pcs	M6x30 Dx40Pcs	Ex12Pcs
				
Fx1Pc	M6 Gx8Pcs	Hx8Pcs	Kx1Pc	M6x35 Lx8Pcs
				
Mx1Pc				

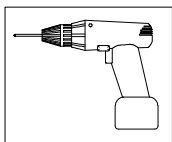

PLEASE BE CAREFUL. DO NOT DAMAGE THE HOLE POSITION WHEN YOU USE POWER TOOLS !

Step 1

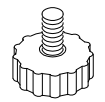

M6
Gx8Pcs

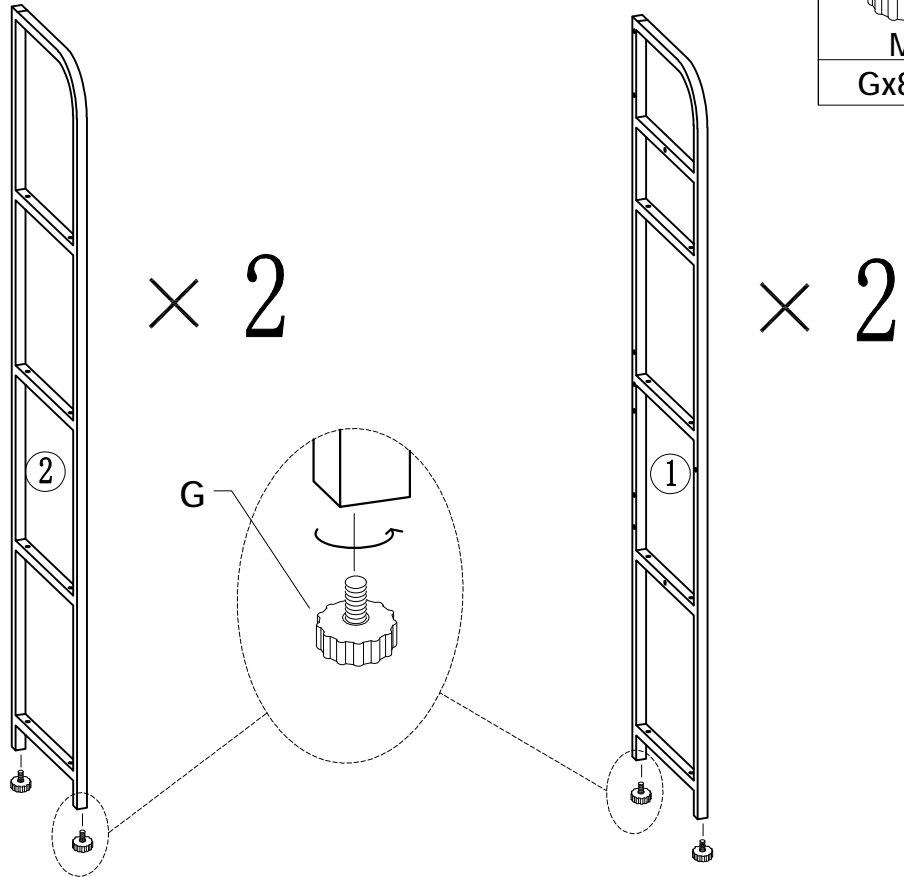

Step 2

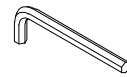

Fx1Pc



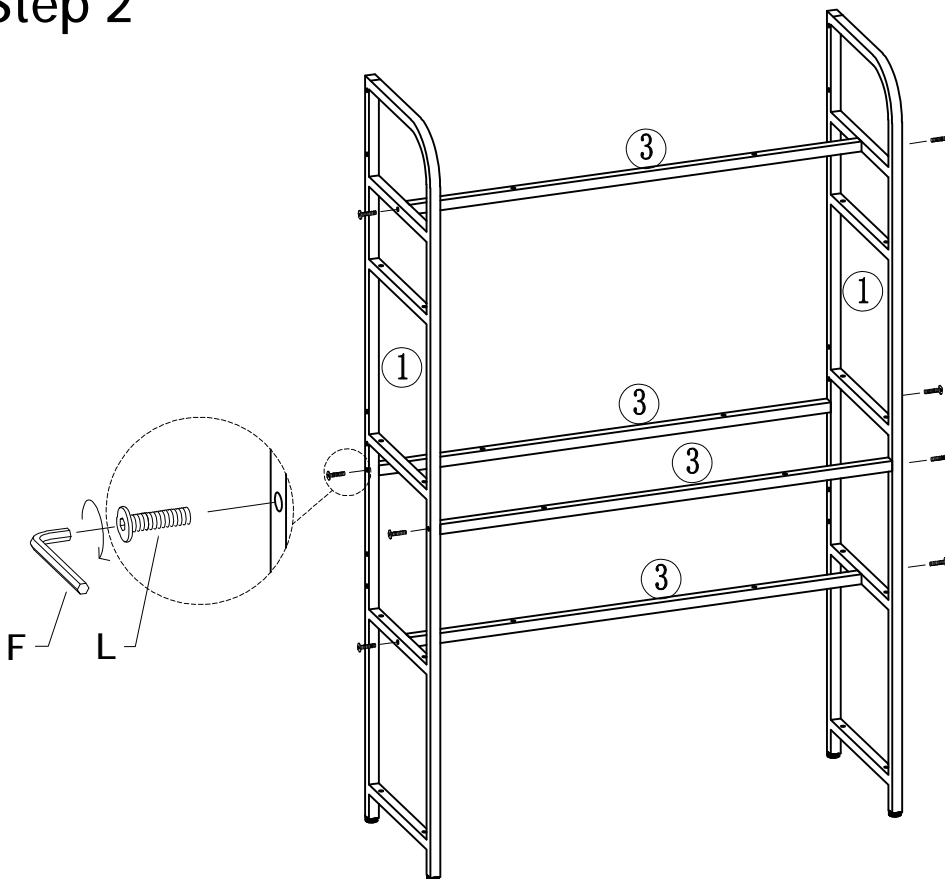

M6x35
Lx8Pcs

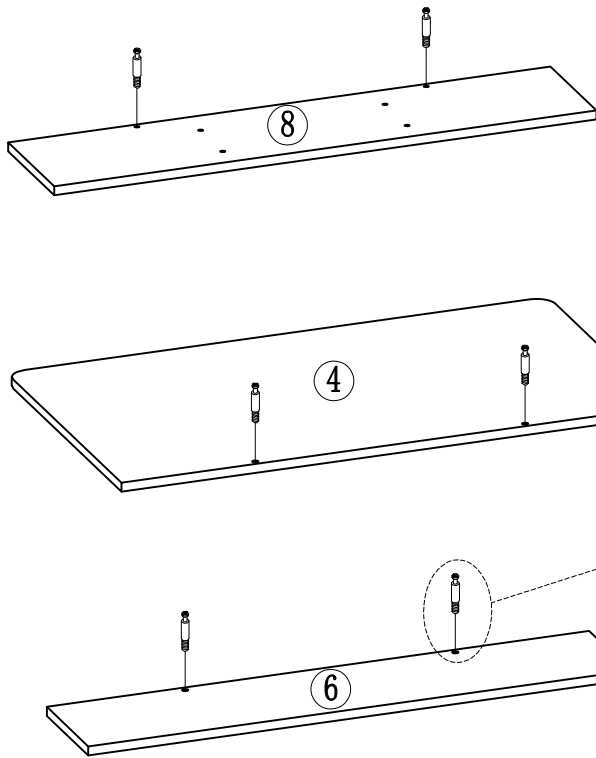

Step 3





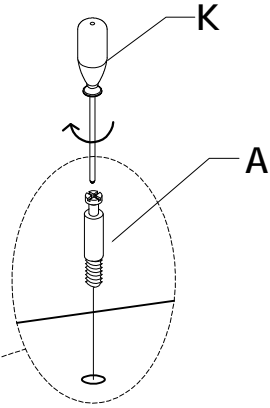

	
Kx1Pc	Ax6Pcs

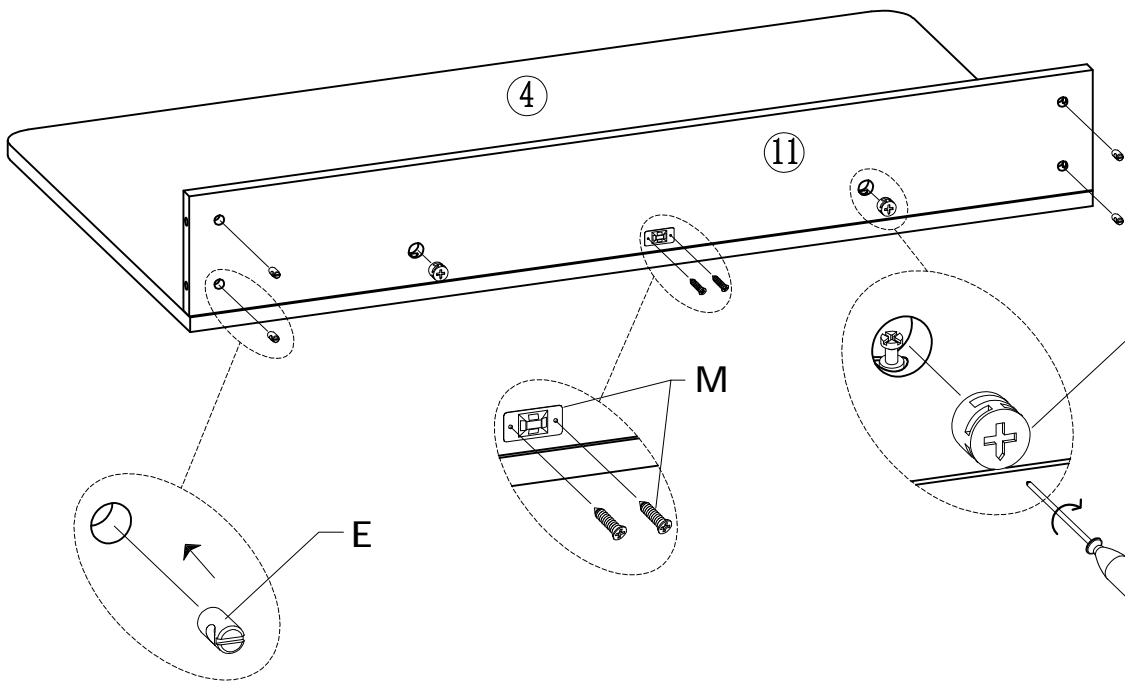

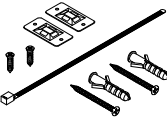
Step 4

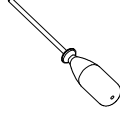

			
Mx1Pc	Ex4Pcs	Kx1Pc	Bx2Pcs

Step 5



Ex4Pcs



Kx1Pc



Bx2Pcs

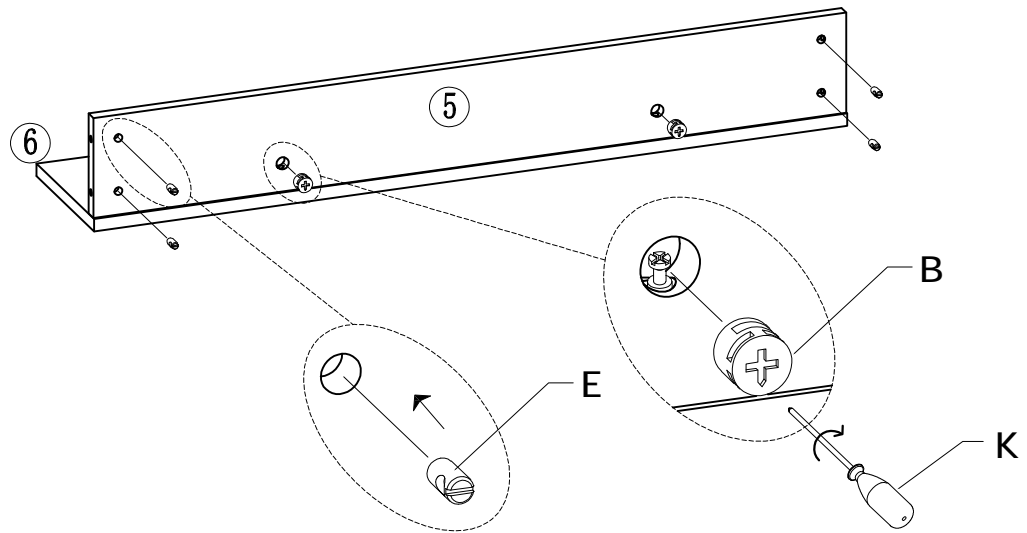

Step 6

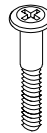

Hx8Pcs



Ex4Pcs

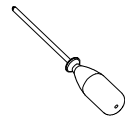

Kx1Pc



Bx2Pcs

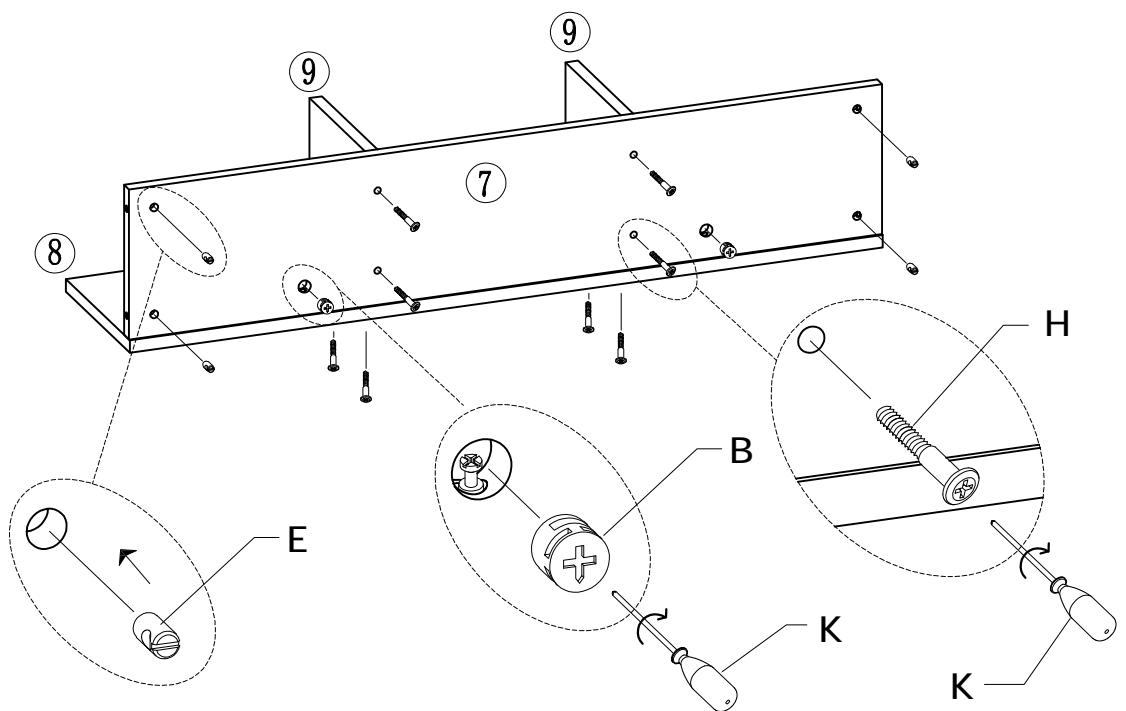

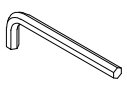
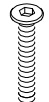

Step 7

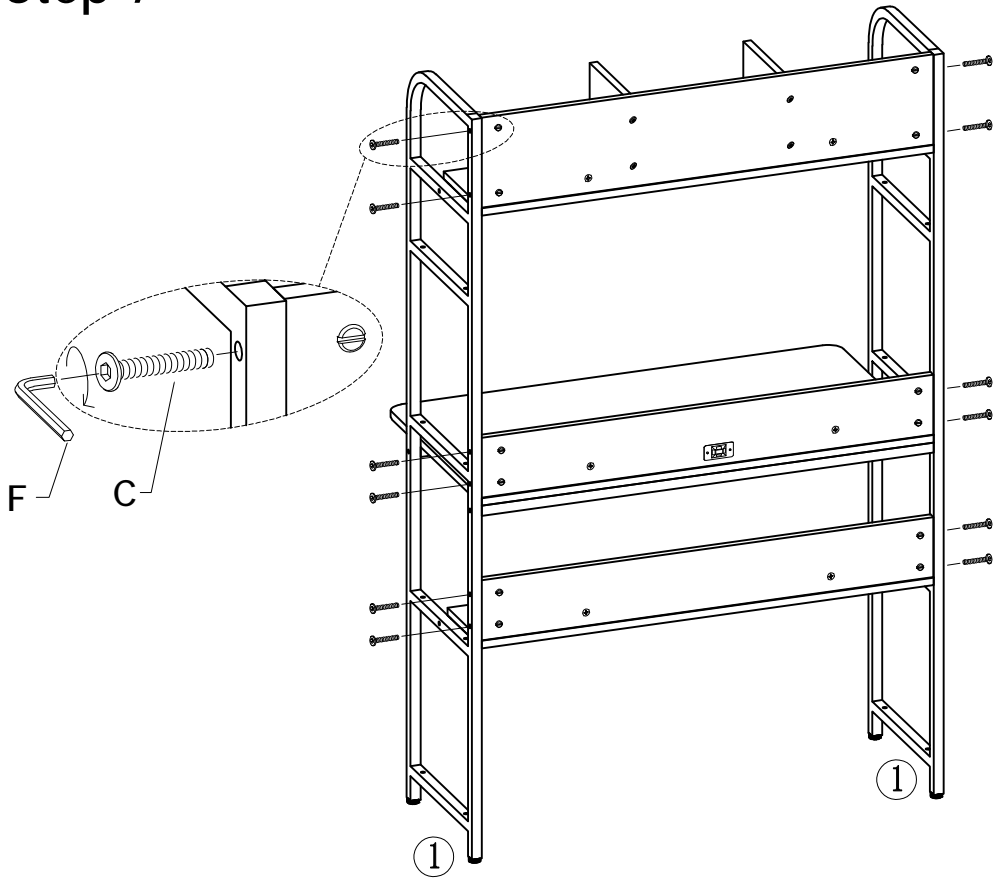
	
Fx1Pc	M6x50 Cx12Pcs



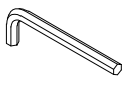

Step 8

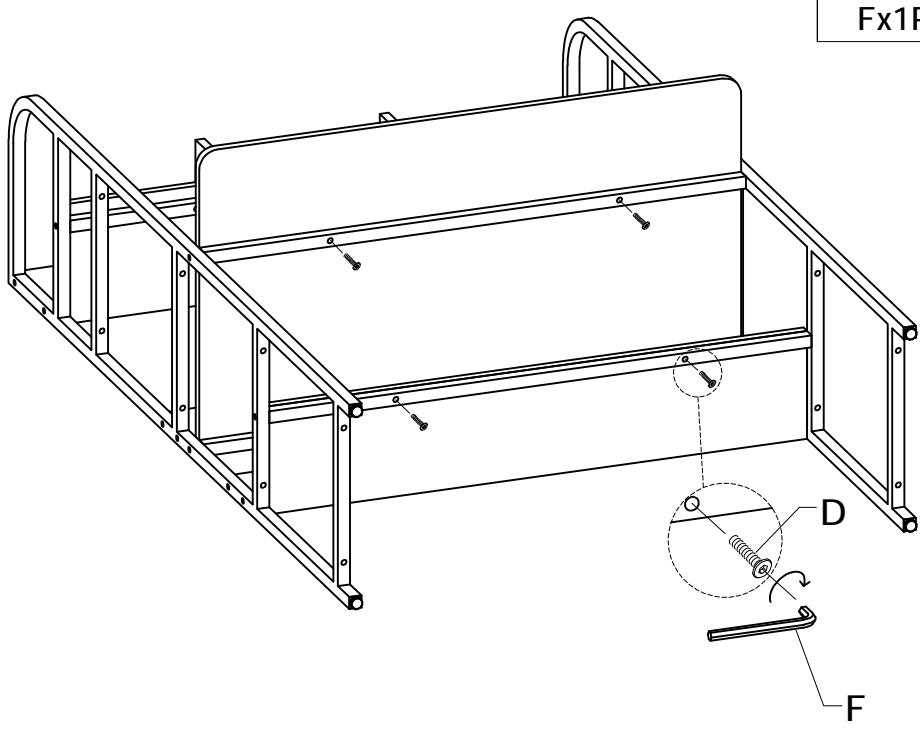
	
Fx1Pc	M6x30 Dx8Pcs

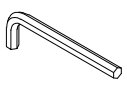

Step 9

	
Fx1Pc	M6x30 Dx32Pcs

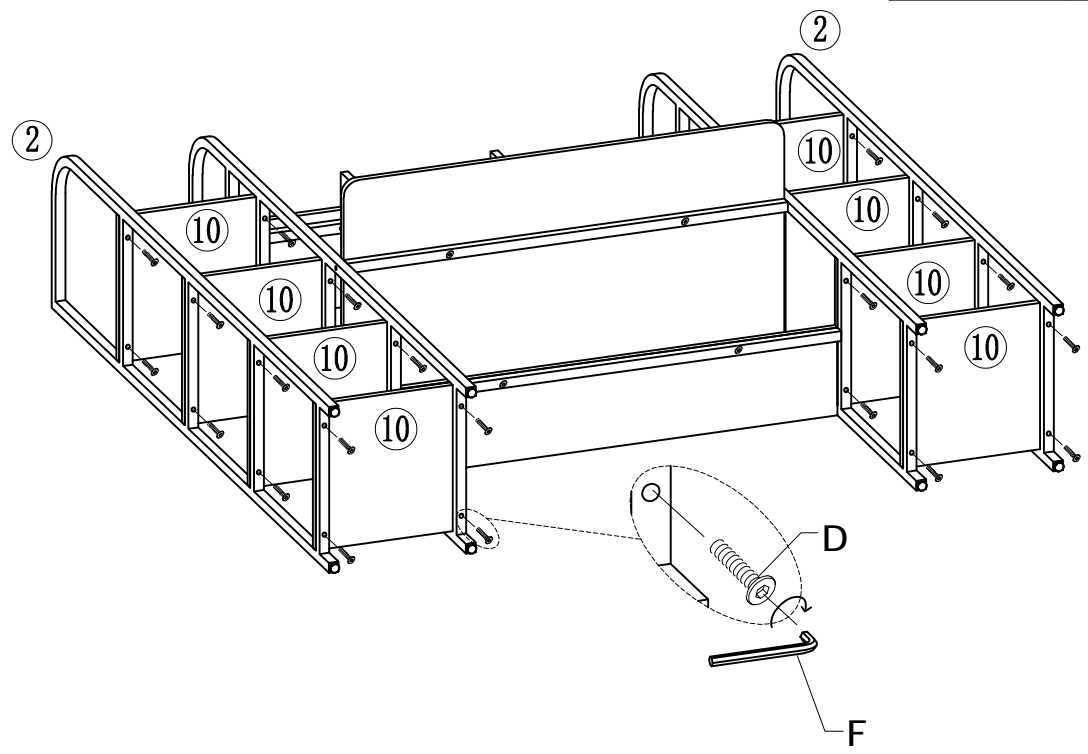

Step 10

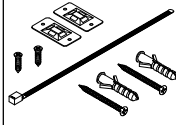
Mx1Pc

