

ASSEMBLY INSTRUCTIONS

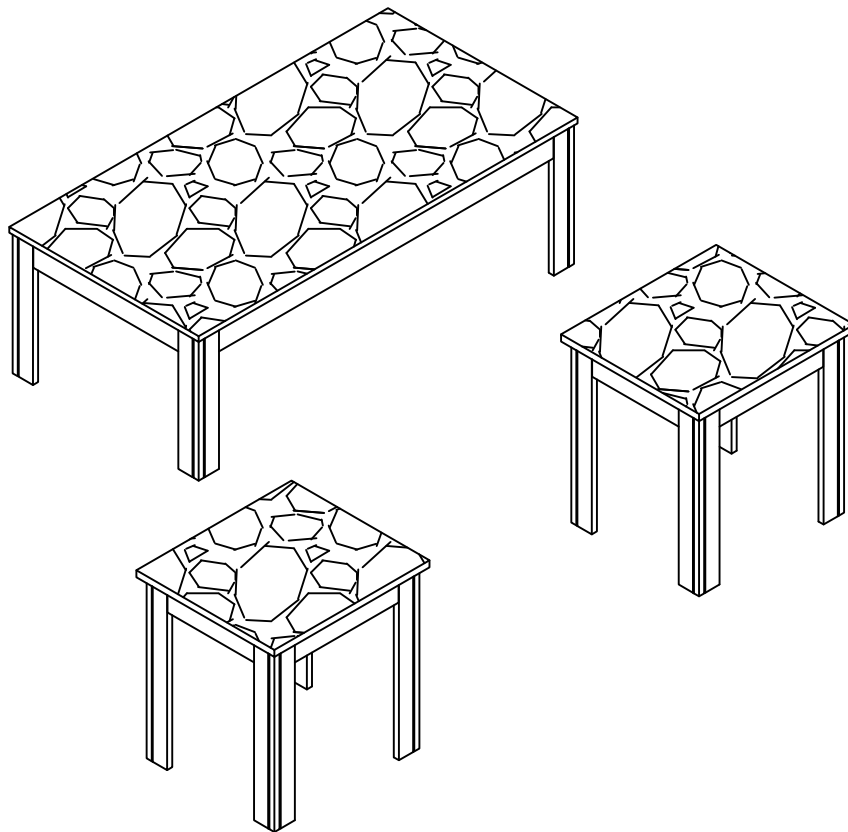

3 Pc Set

ASSEMBLY INSTRUCTIONS

ASSEMBLY TIPS:

- 1.Remove hardware from box and sort by size.
- 2.Please check to see that all hardware and parts are present prior to start of assembly.
- 3.Please follow attached instructions in the same sequence as numbered to assure fast & easy assembly.



Warning !!

1. Don't attempt to repair or modify parts that are broken or defective. Please contact the store immediately.
2. This product is for home use only and not intended for commercial establishment.



ASSEMBLY TIME

30 MINUTES

PARTS IDENTIFICATION

(A) WOOD TOP-COFFEE TABLE

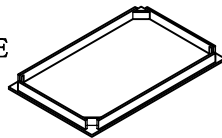

1 PC

(C) WOOD TOP-END TABLE

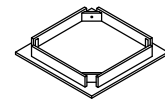

2 PCS

(B) LEG-COFFEE TABLE

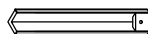

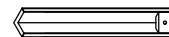

4 PCS

(D) LEG-END TABLE



8 PCS

HARDWARE IDENTIFICATION

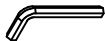
1	WASHER	ø5/16*22mm		12pcs
2	LOCK WASHER	ø5/16mm		12pcs
3	BOLT	ø5/16*2-1/4"mm		12pcs
4	ALLEN WRENCH	5mm		1pc

ASSEMBLY INSTRUCTIONS

STEP 1

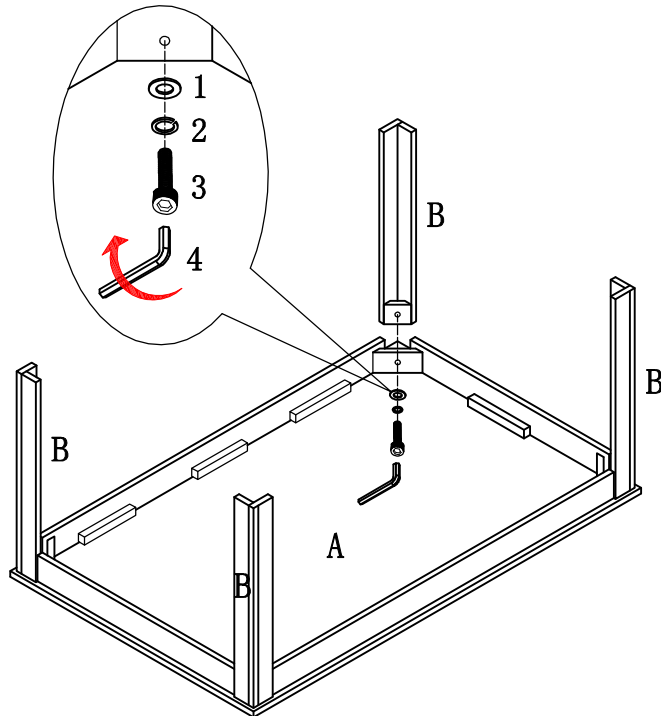

STEP 2

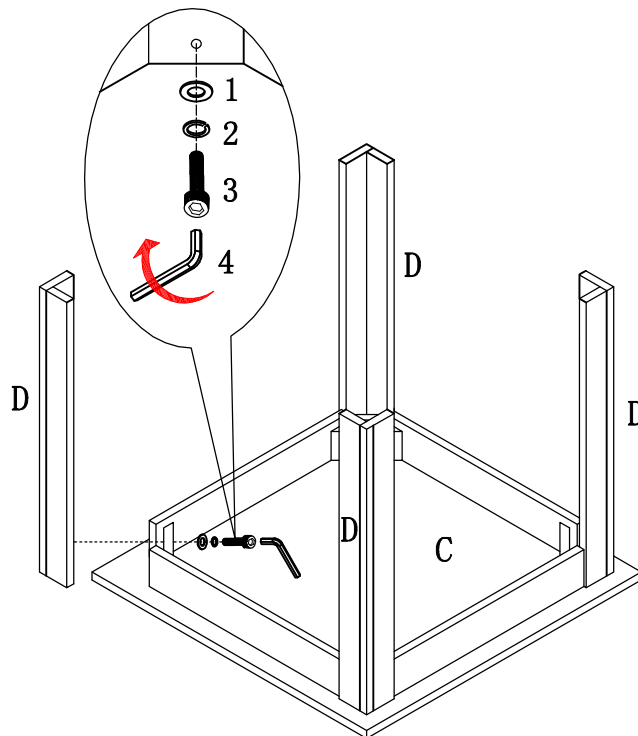

DIMENSION

