

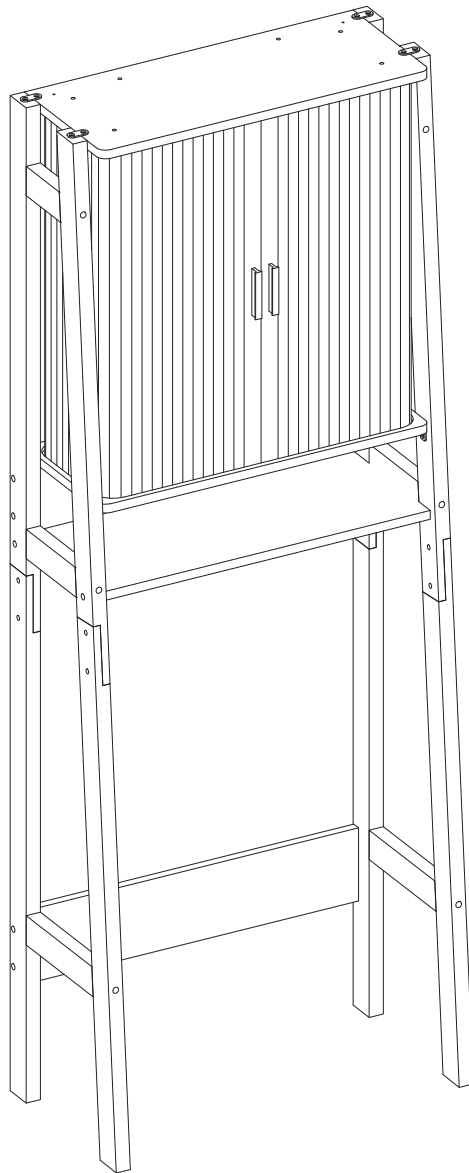

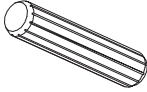

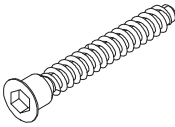

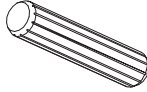
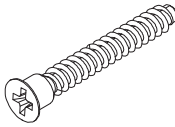
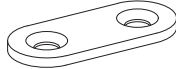
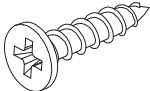

Assembly Instructions

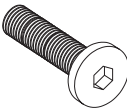

Part List

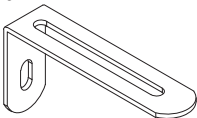
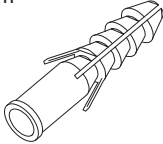
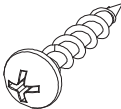
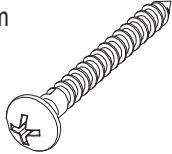
<p>No. A Quantity: 32+2 PCS Dowel ø8x30mm</p> 	<p>No. B Quantity: 24+2 PCS Screw ø6x48mm</p> 	<p>No. C Quantity: 16+1 PCS Dowel ø6x30mm</p> 	<p>No. D Quantity: 16+1 PCS Screw ø5x48mm</p> 
<p>No. E Quantity: 4 PCS 36x16x2mm</p> 	<p>No. F Quantity: 8+1 PCS Screw ø3.5x12mm</p> 	<p>No. G Quantity: 2 PCS</p> 	<p>No. H Quantity: 2 PCS Handle</p> 
<p>No. I Quantity: 4+1 PCS Screw M4x10mm</p> 	<p>No. J Quantity: 8 PCS Bolt M6x20mm</p> 	<p>No. K Quantity: 4 PCS Bolt M6x12mm</p> 	<p>No. L Quantity: 2 PCS Hex Key 4mm</p> 
<p>No. M Quantity: 2 PCS L-Shaped anti tipping iron bar 76x15x30mm</p> 	<p>No. N Quantity: 2 PCS Plastic Expansion ø8x40mm</p> 	<p>No. O Quantity: 2 PCS Screw ø4x14mm</p> 	<p>No. P Quantity: 2 PCS Screw ø4x38mm</p> 
<p>No. Q Quantity: 24+2 PCS Sticker ø20mm</p> 	<p>No. R Quantity: 8 PCS</p> 	<p>No. S Quantity: 4 PCS ø5x19mm</p> 	

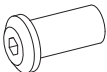
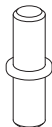
Product structure

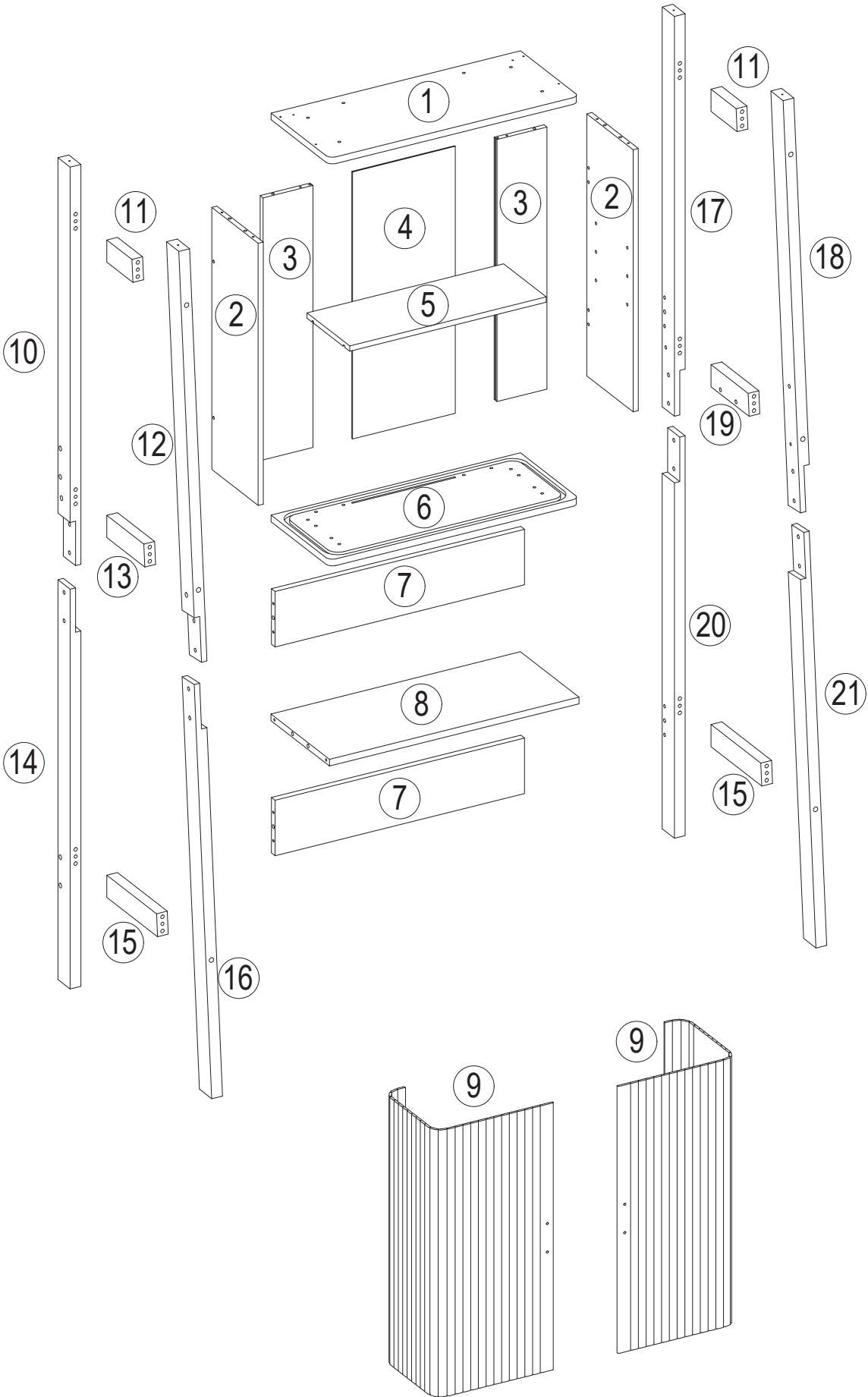

STEP 1

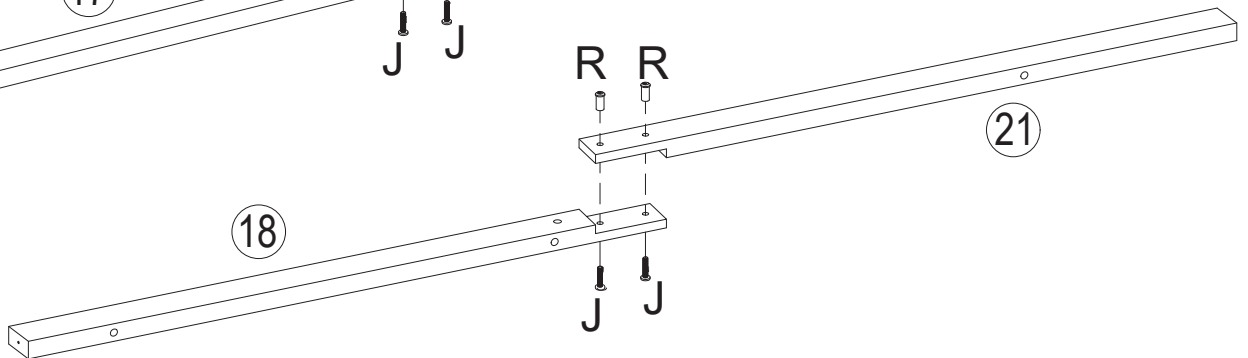
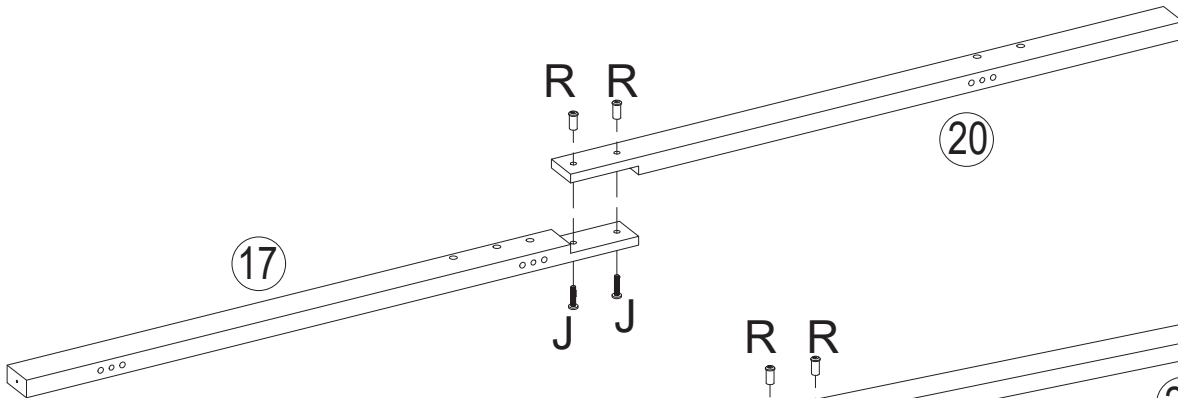
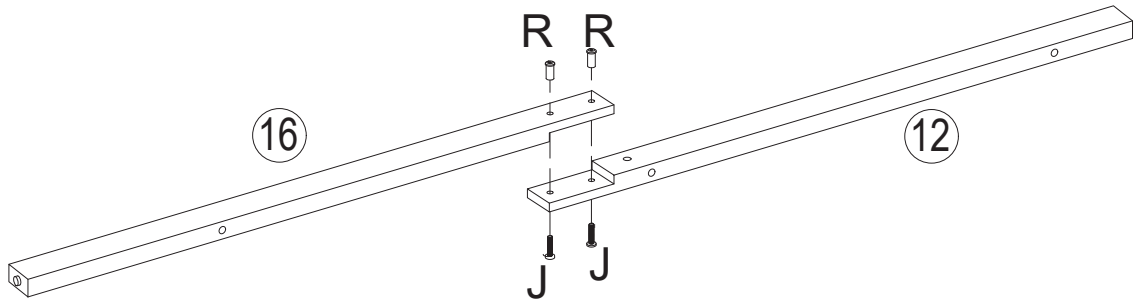
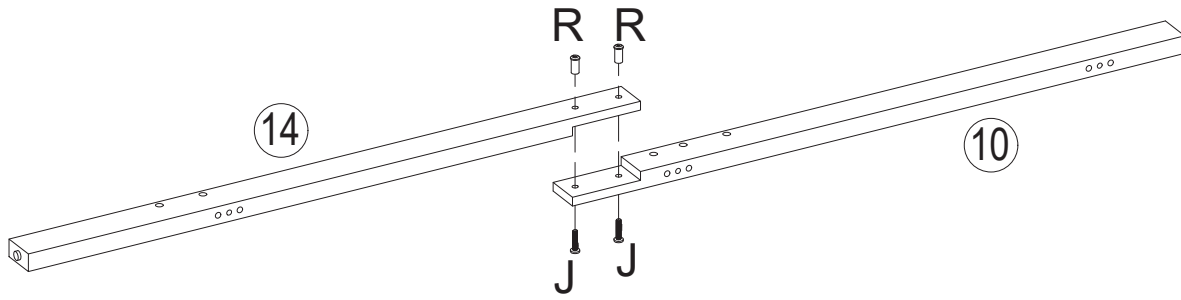

No. J
Quantity: 8 PCS
Bolt
M6x20mm

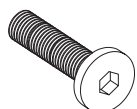

No. R
Quantity: 8 PCS

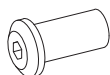

No. L
Quantity: 2 PCS
Hex Key
4mm



STEP 2

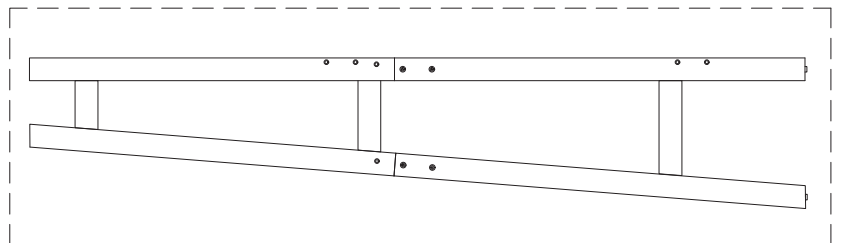
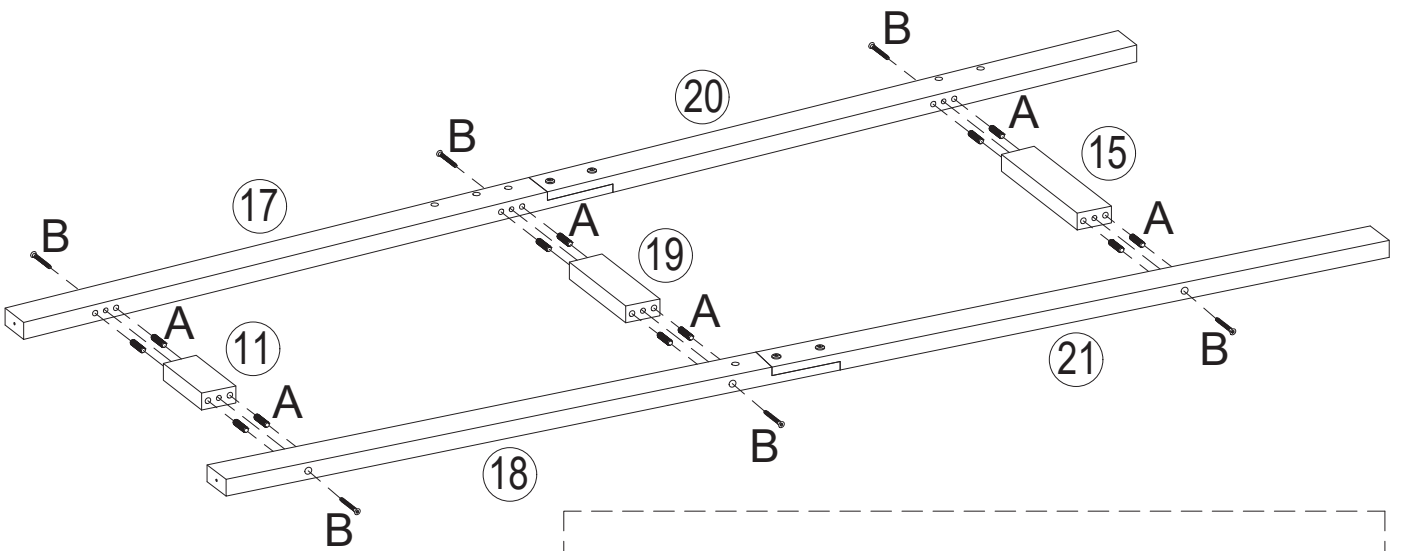
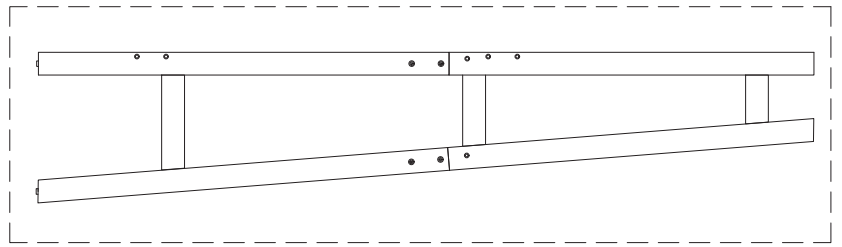
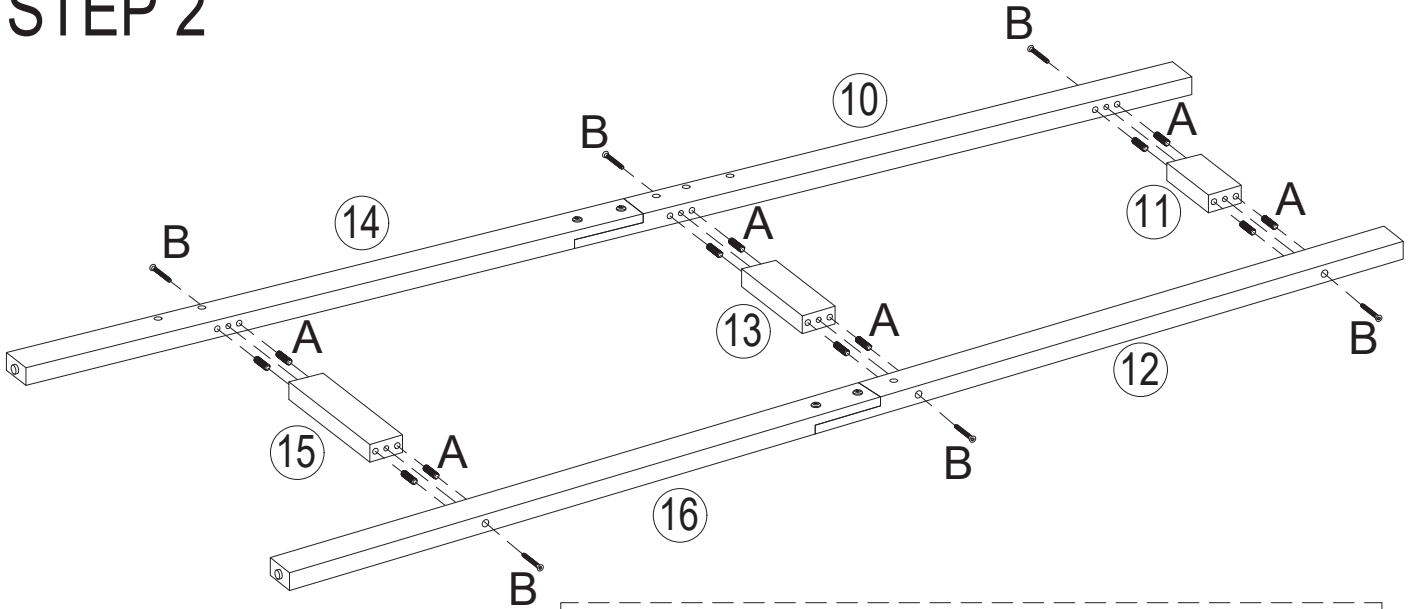

No. A
Quantity: 24 PCS
Dowel
ø8x30mm

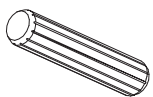

No. B
Quantity: 12 PCS
Screw
ø6x48mm

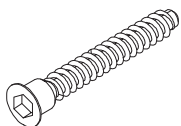

No. L
Quantity: 1 PCS
Hex Key
4mm



STEP 3

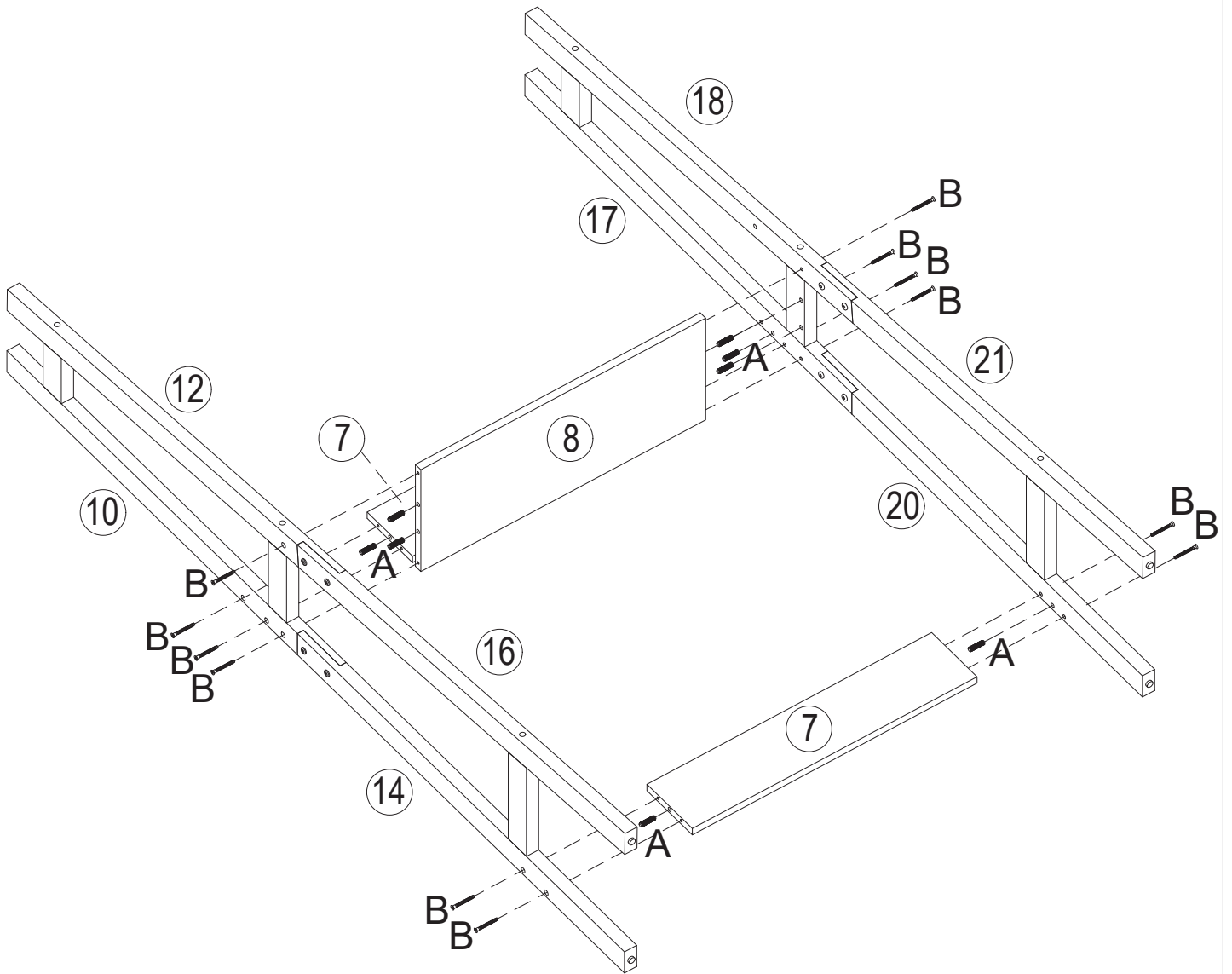

No. A
Quantity: 8 PCS
Dowel
ø8x30mm

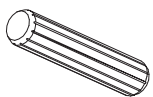

No. B
Quantity: 12 PCS
Screw
ø6x48mm

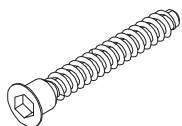

No. L
Quantity: 1 PCS
Hex Key
4mm



STEP 4

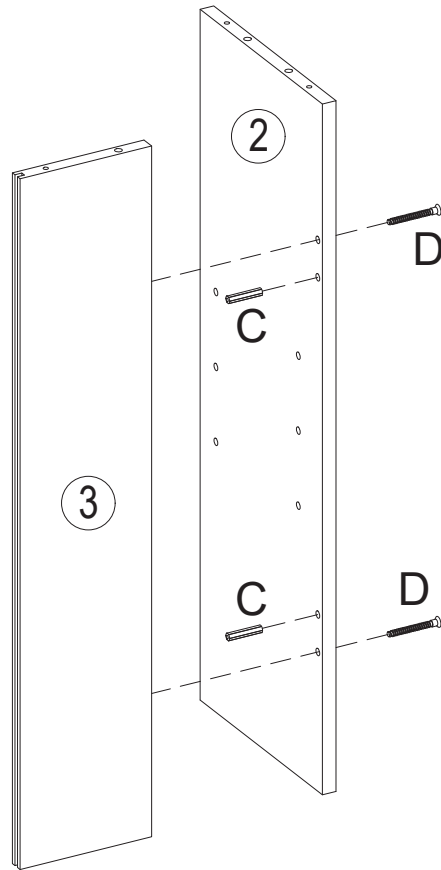

x2

No. C
Quantity: 4 PCS
Dowel
ø6x30mm

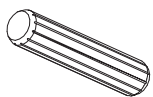

No. D
Quantity: 4 PCS
Screw
ø5x48mm

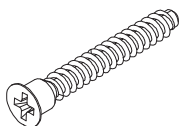

STEP 5

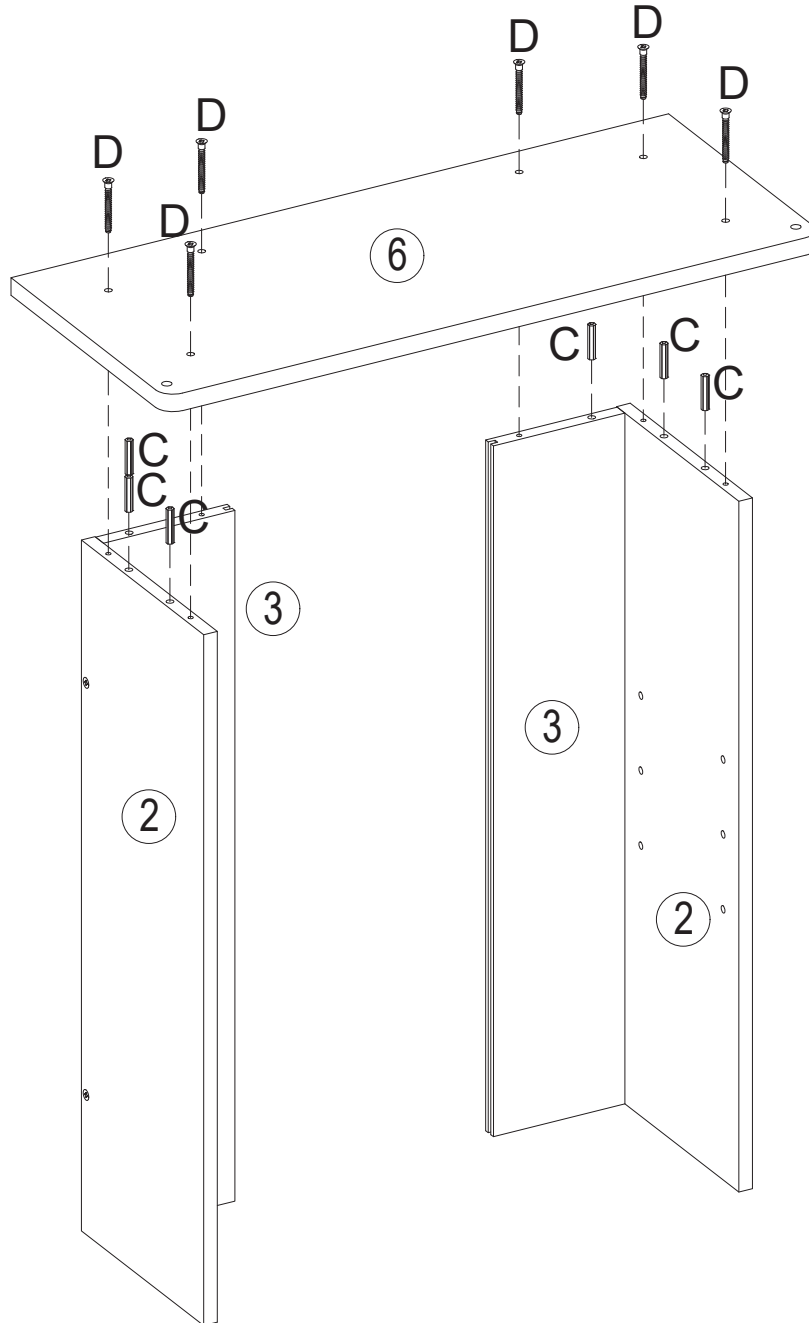

No. C
Quantity: 6 PCS
Dowel
ø6x30mm

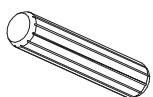

No. D
Quantity: 6 PCS
Screw
ø5x48mm

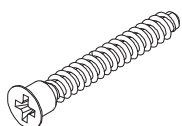

STEP 6

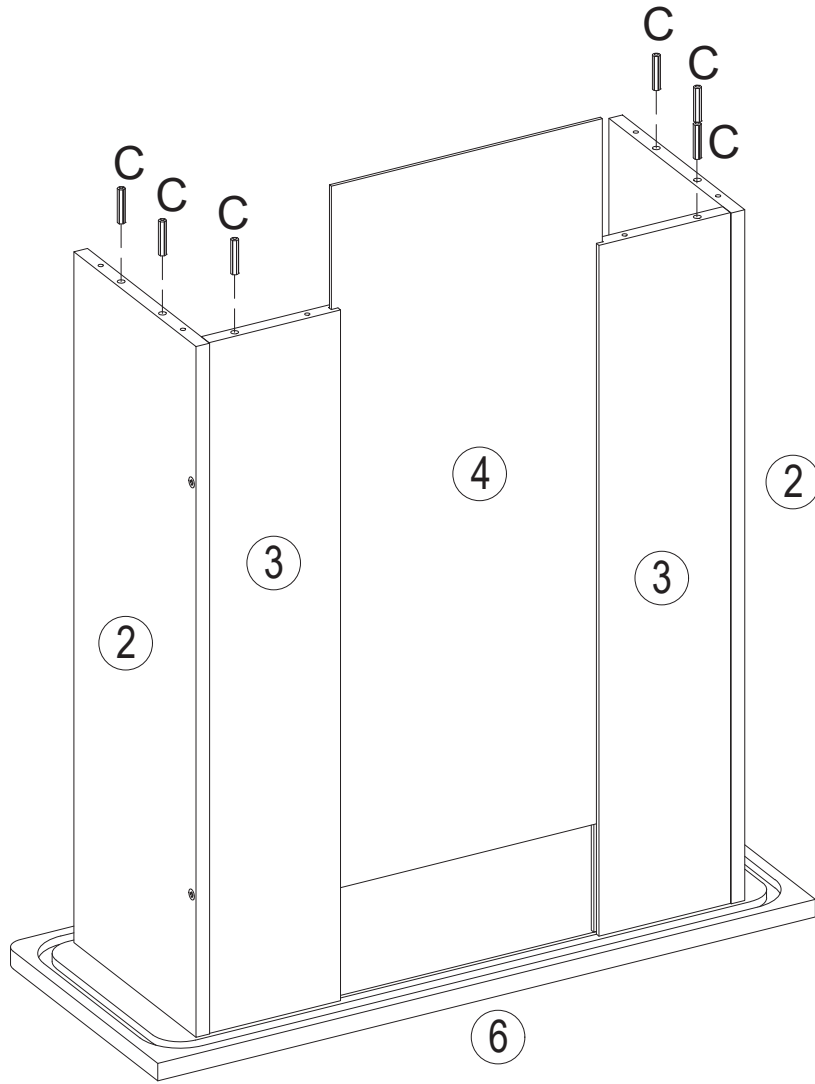

No. C
Quantity: 6 PCS
Dowel
ø6x30mm

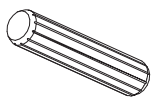

STEP 7

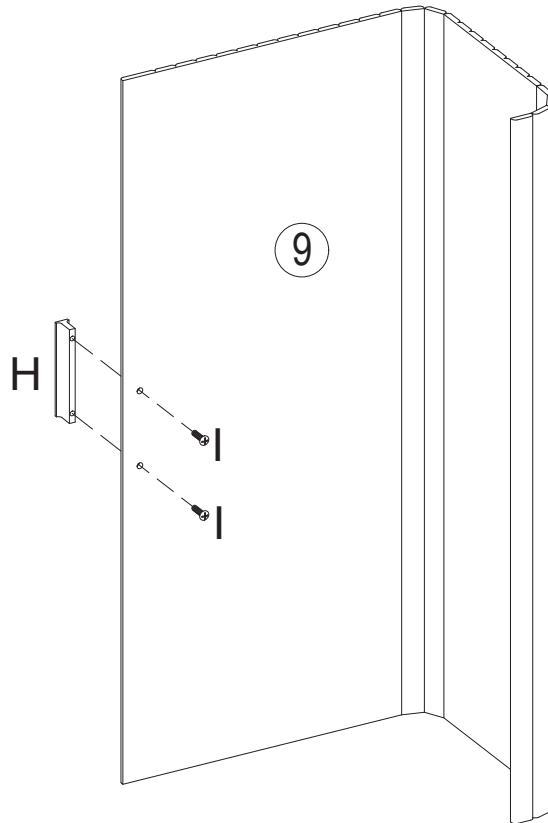

x2

No. H
Quantity: 2 PCS
Handle



No. I
Quantity: 4 PCS
Screw
M4x10mm

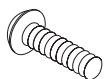

STEP 8

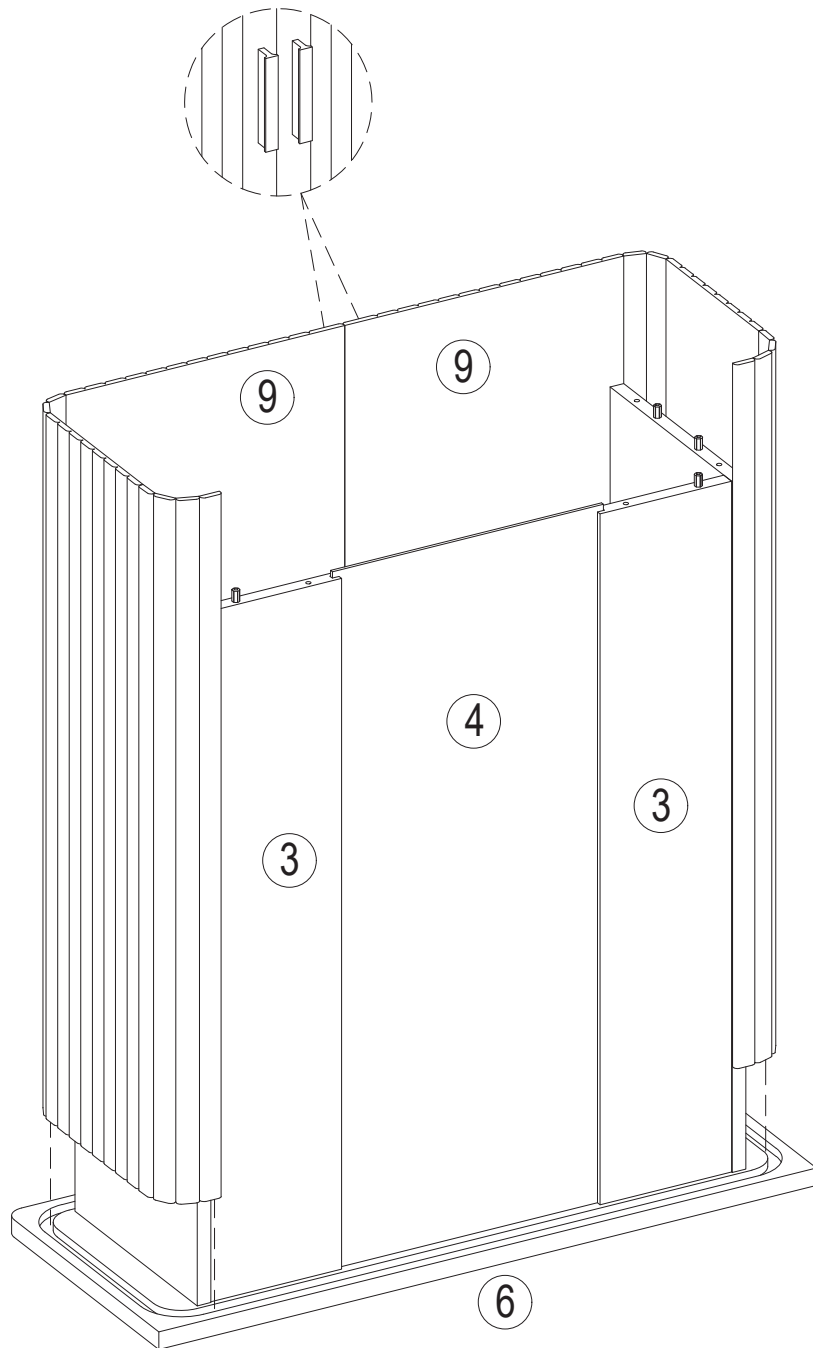

Make sure the sliding door is properly inserted into the groove to ensure smooth operation.

STEP 9

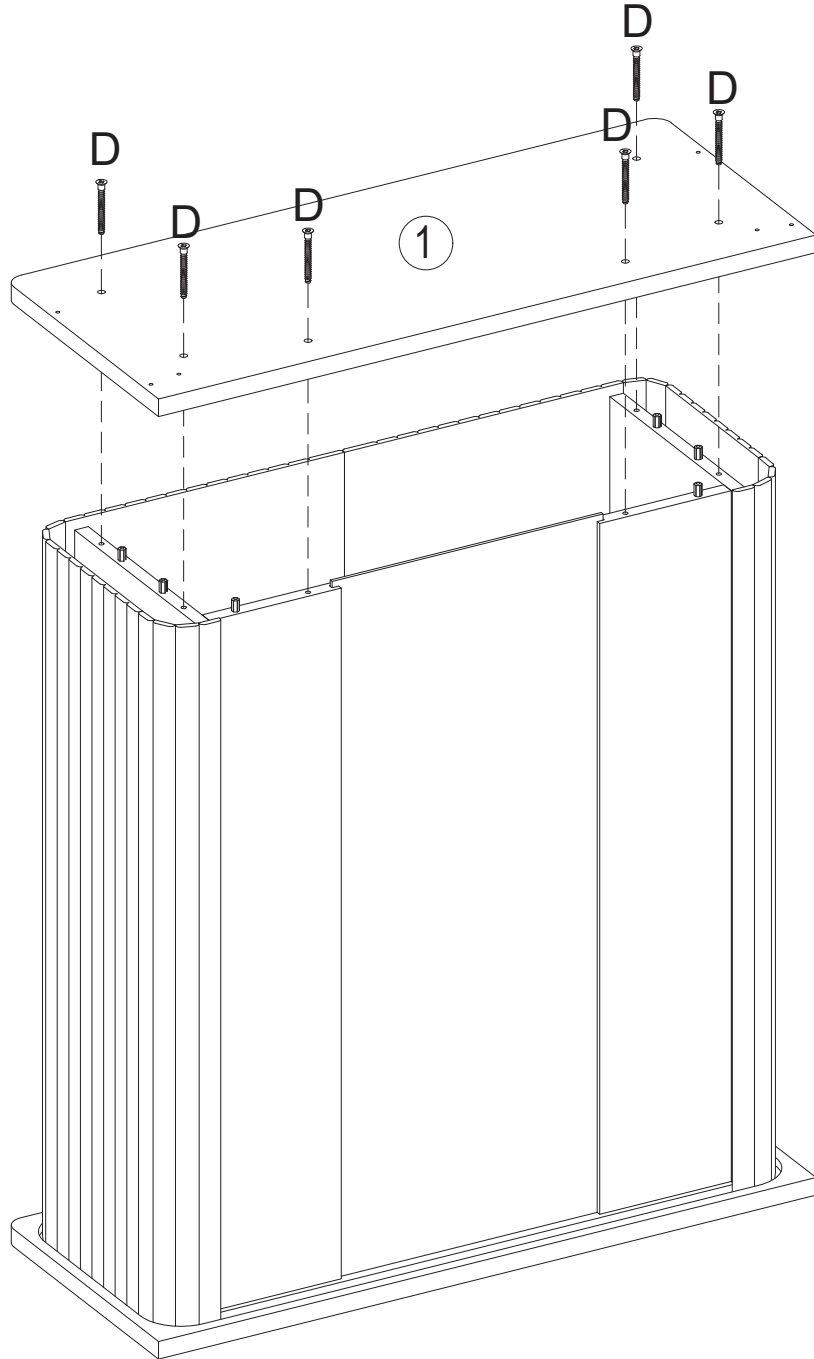

No. D
Quantity: 6 PCS
Screw
ø5x48mm

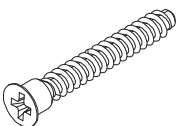

STEP 10

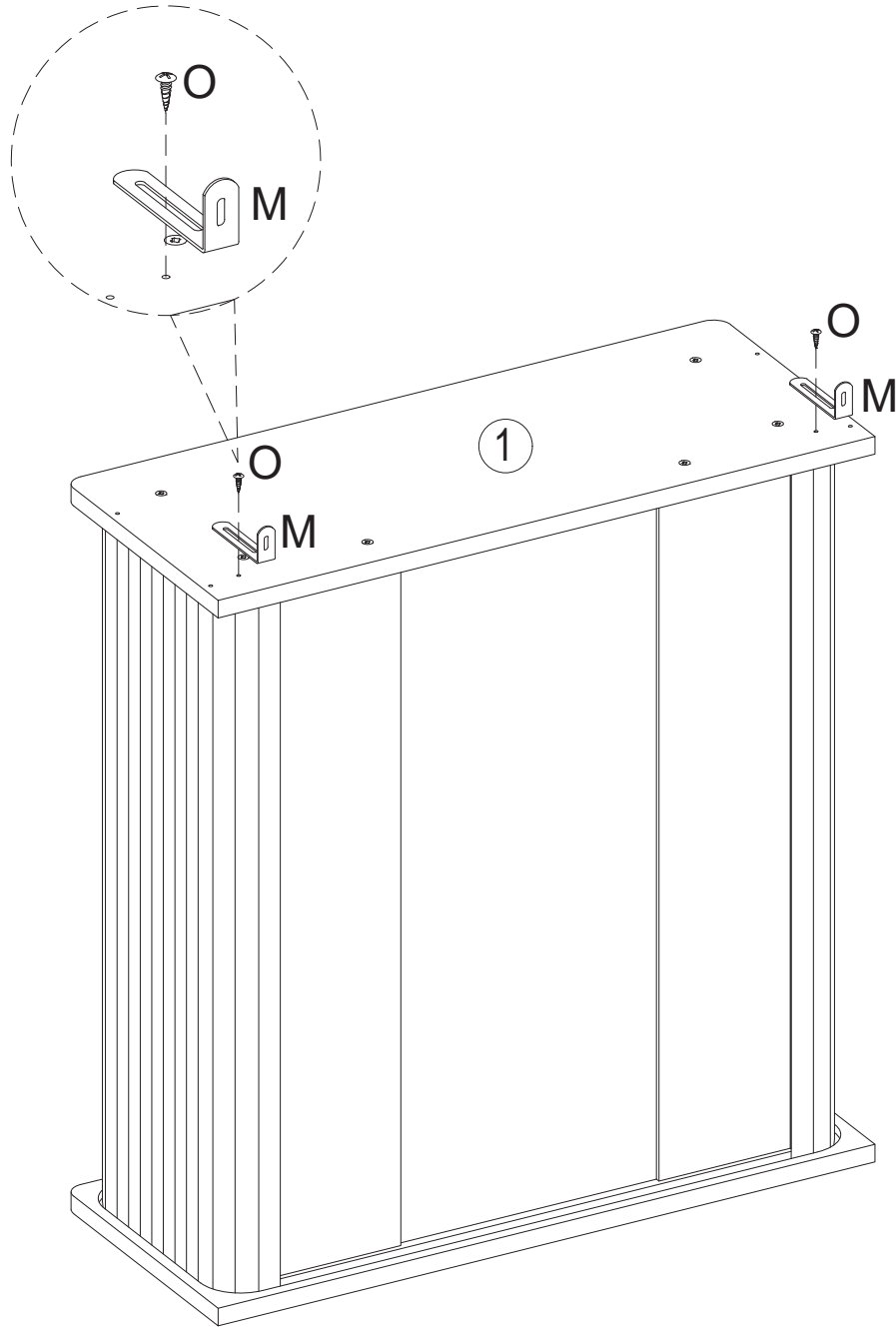

No. M

Quantity: 2 PCS
L-Shaped anti tipping iron
bar
76x15x30mm

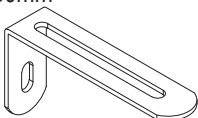

No. O

Quantity: 2 PCS
Screw
ø4x14mm

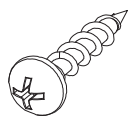

STEP 11

Tighten All bolt #K to 80% first.
After completing Step12,
tighten All bolt completely.

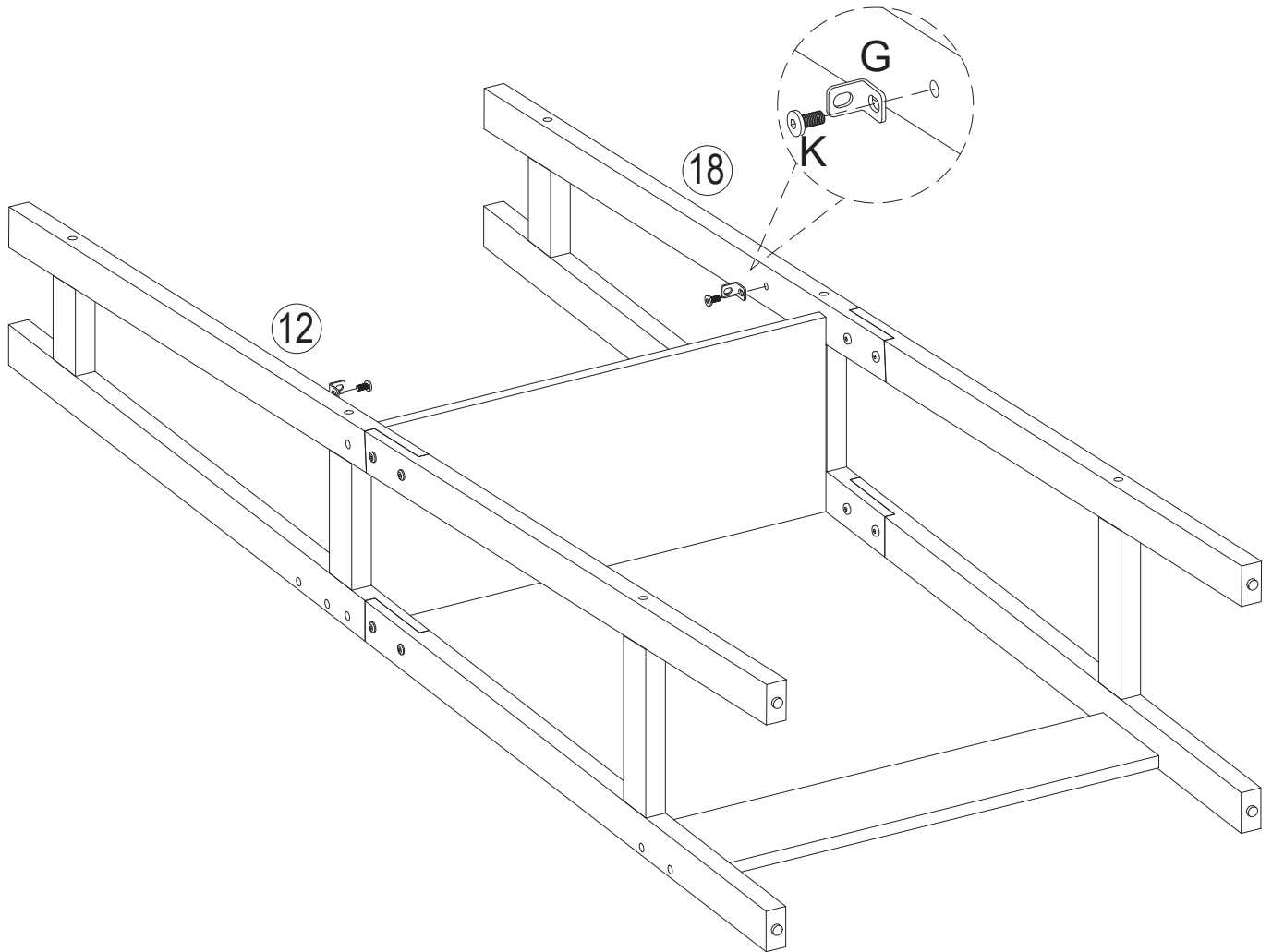

No. G
Quantity: 2 PCS



No. K
Quantity: 2 PCS
Bolt
M6x12mm

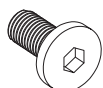

No. L
Quantity: 1 PCS
Hex Key
4mm



STEP 12

NOTE:
Tighten all Bolt #K

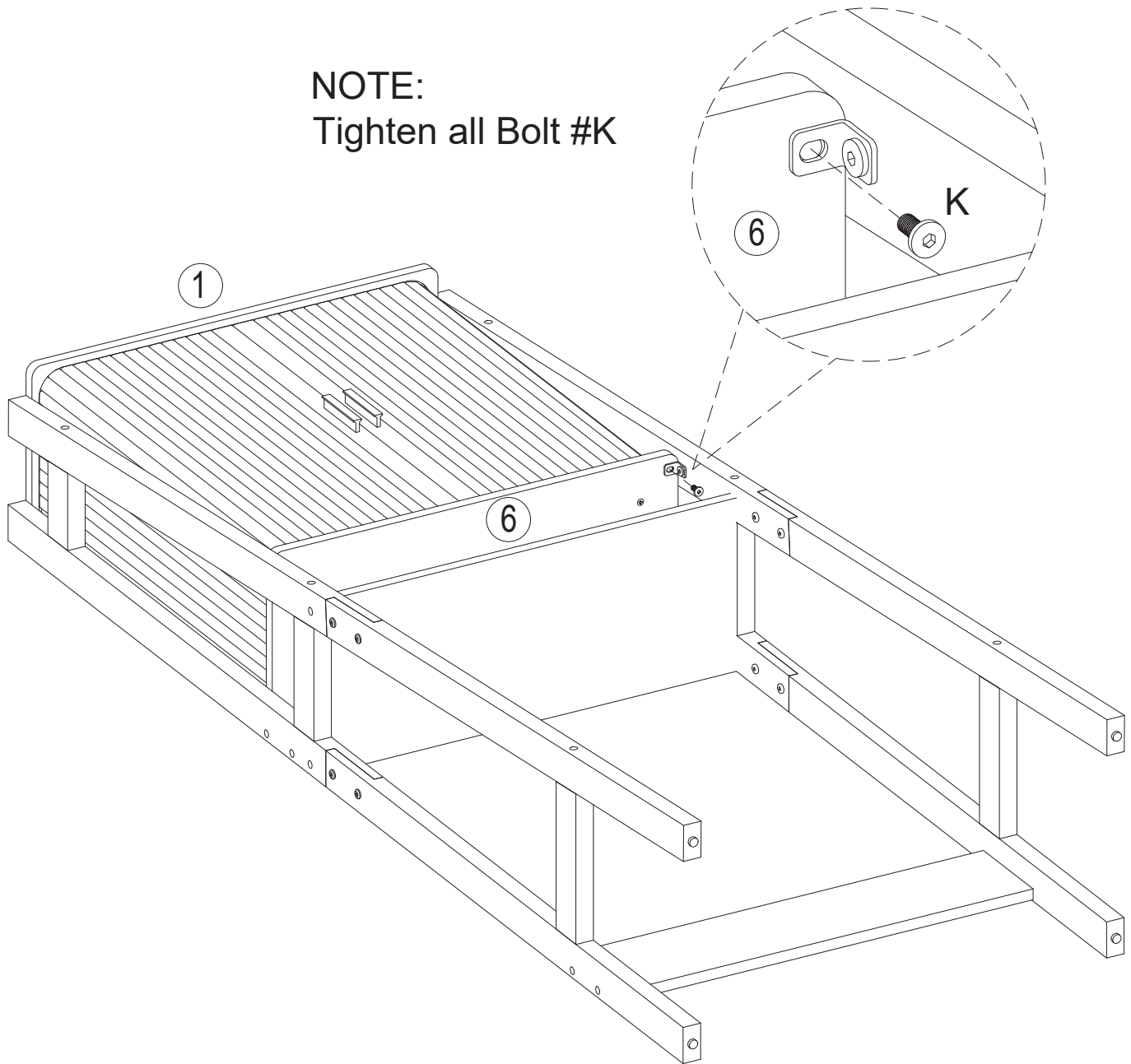

No. K
Quantity: 2 PCS
Bolt
M6x12mm

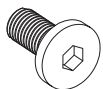

No. L
Quantity: 1 PCS
Hex Key
4mm



STEP 13

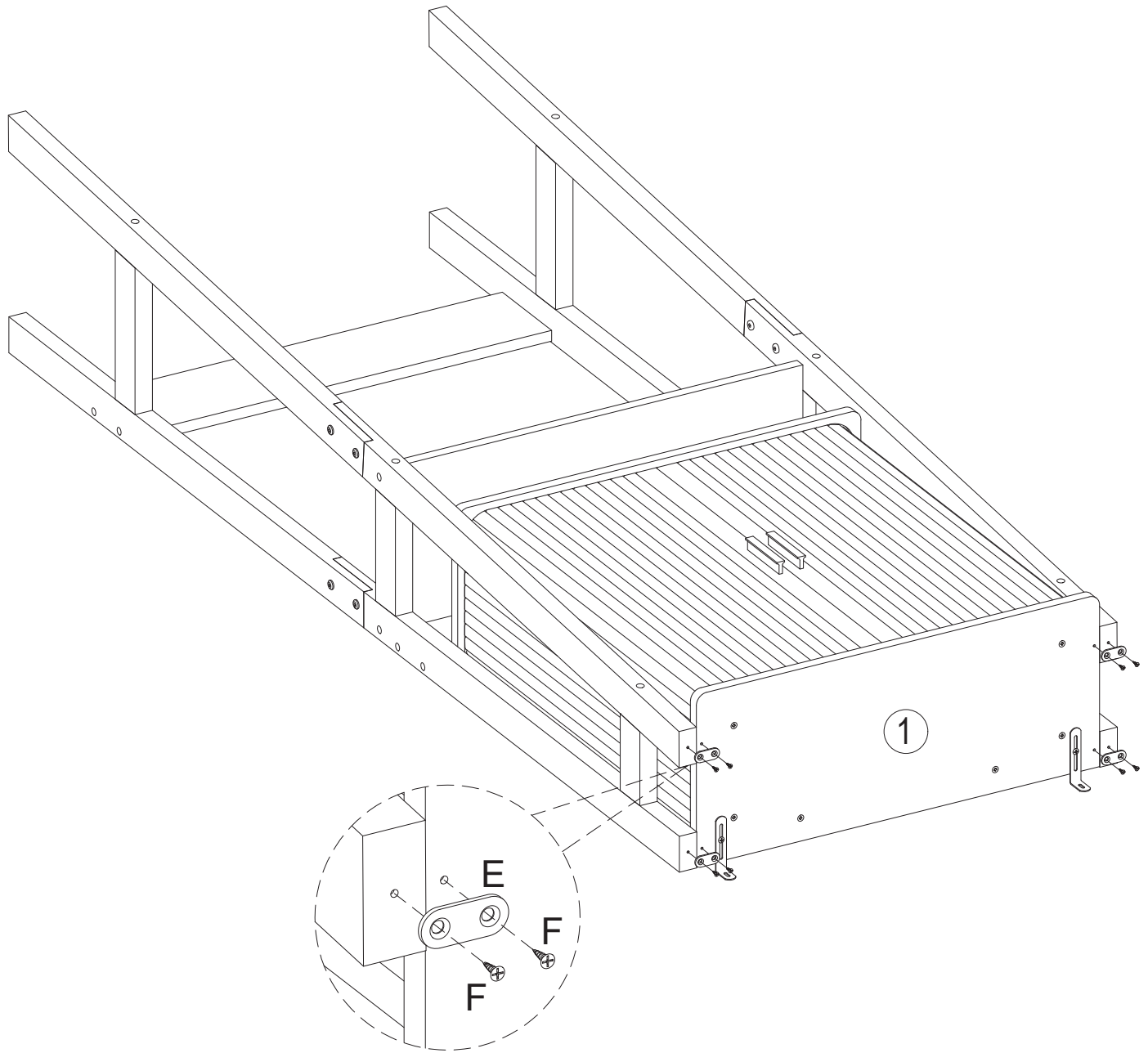

No. E
Quantity: 4 PCS
36x16x2mm

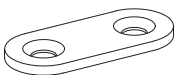

No. F
Quantity: 8 PCS
Screw
ø3.5x12mm

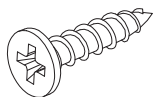

STEP 14

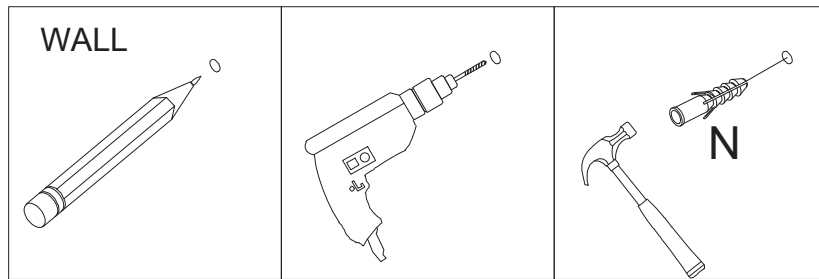

No. N
Quantity: 2 PCS
Plastic Expansion
ø8x40mm

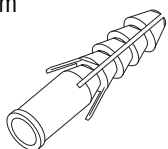

No. P
Quantity: 2 PCS
Screw
ø4x38mm

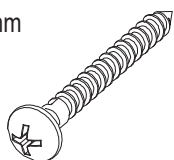

STEP 15

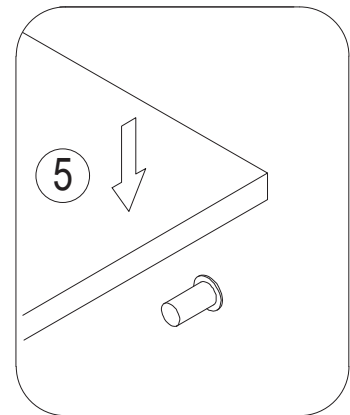
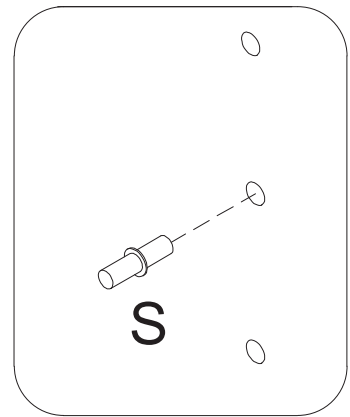
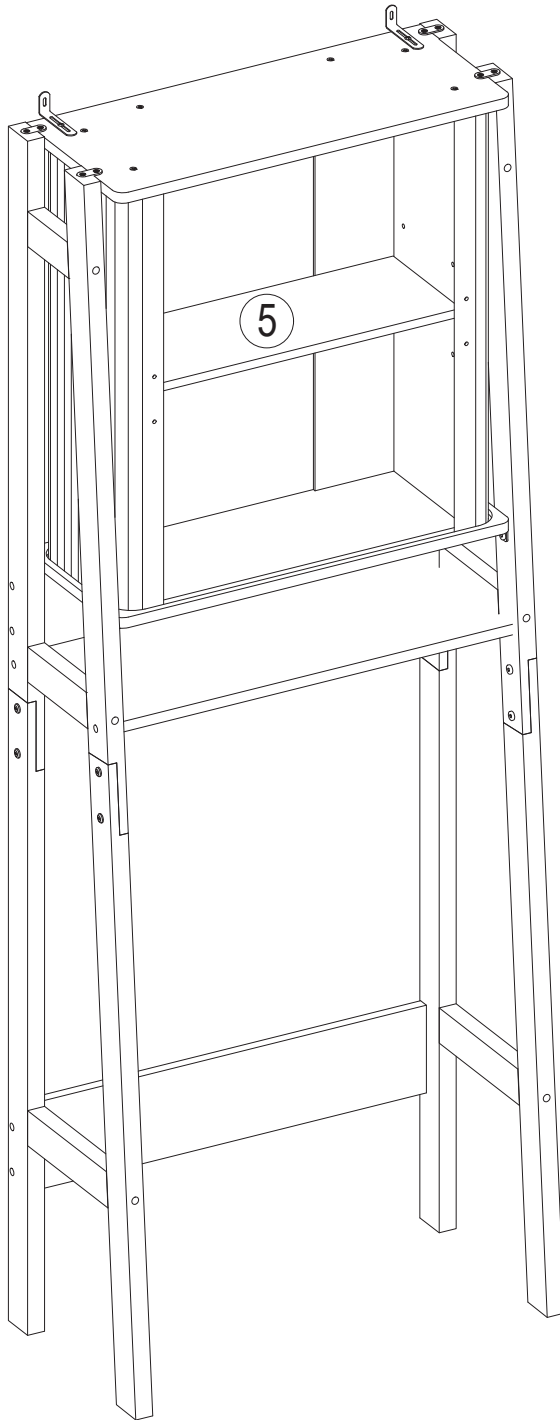
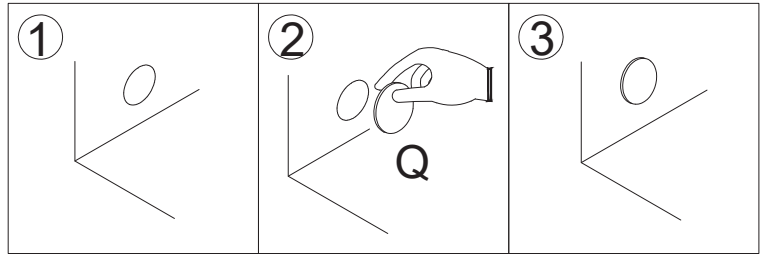

No. S
Quantity: 4 PCS
ø5x19mm

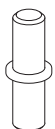

No. Q
Quantity: 24 PCS
Sticker
ø20mm



STEP 16

