

















ASSEMBLY INSTRUCTIONS

Caution: Please read instructions thoroughly before unpacking assembly parts. Sharp, exposed staple tips can cause injury. Therefore, for your protection, please remove any exposed staples used in packing.

Please keep all hardware parts out of the reach of children.

1. We recommend that you should assemble this product with the assistance of another person; this will make assembly easier and will help to eliminate damage to the product or injury to persons during assembly.
2. Be sure to check all packing materials carefully for small parts that may have come loose inside the carton during shipment.
3. Please do not over tighten screws or bolts.
4. Please put all parts on a non-abrasive floor before assembly, and follow the assembly steps to assemble your newly purchased product correctly and efficiently.

Components List :			
NO.		DESCRIPTION	Q' TY
A		HB Right Leg	1pc
B		HB Left Leg	1pc
C		Headboard	1pc
D		Wood stretcher	1pc
E		Footboard	1pc
F		Side rail	2pcs
G		Slat	4pcs
H		Support Leg	8pcs

Hardware List				
NO.	DESCRIPTION	SIZE	SKETCH	Q' TY
1	Flat Washer	8*19*2mm		8pcs
2	Spring Washer	8mm		16pcs
3	Allen Bolts	1/4"*1-9/16"		2pcs
4	Allen Bolts	5/16"*1-9/16"		6pcs
5	Allen Key	4*30*80mm		1pc
6	Allen bolt	5/16" * 3"		8pcs
7	Half moon washer	Ø5/16"		8pcs
8	Hex Nut	Ø5/16"*12mm		8pcs
9	Wrench	12mm		1pc
10	Wood Screw	#8*1-1/4"		8pcs

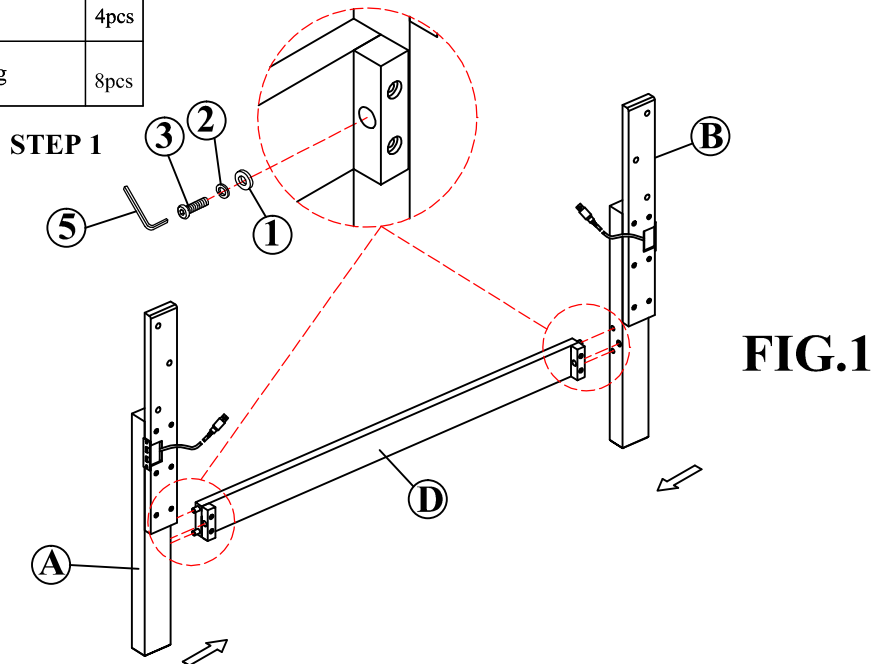

STEP 1: Attach the Wood Stretcher (D) to both Headboard Legs (A&B) using provided hardware as shown on FIG.1

ASSEMBLY INSTRUCTIONS

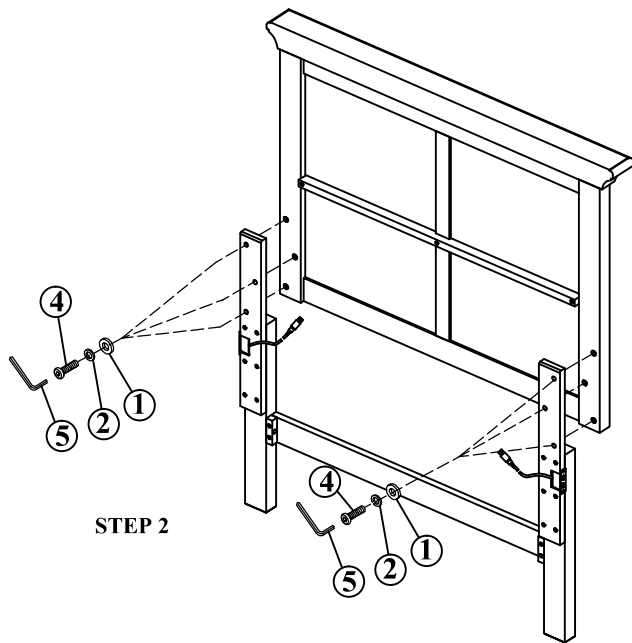

STEP 2: Attach the Headboard (C) to the Legs assembly (A,B&D) using provided hardware as shown on FIG.2

FIG.2

STEP 3: Attach both Bed Rails (F) to the Headboard assembly (A,B,D&C) using the provided hardware as shown on FIG.3

STEP 3: Attach both Bed Rails (F) to the Footboard (E) using the provided hardware as shown on FIG.4

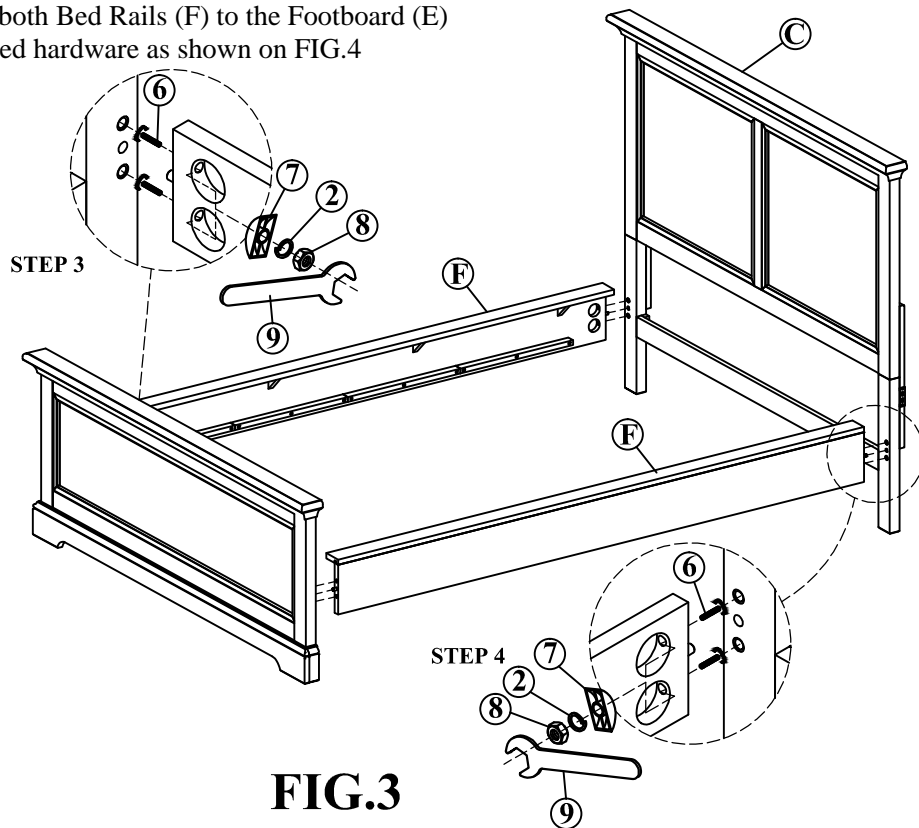

FIG.4

FIG.3

ASSEMBLY INSTRUCTIONS

STEP 5: Attach Support Legs (H) to Slats (G) as shown on FIG.5.
STEP 6: Attach Slats with Support legs (G&H) to the Side Rail (F) using the provided hardware as shown on FIG.6

