

# INSTALLATION INSTRUCTIONS

L516L – PULSAR L



## Read and understand these instructions before installation

This product is intended for installation in accordance with the National Electric Code and local regulations. To assure full compliance with local codes and regulations, check with your local electrical inspector before installation.

To prevent electrical shock, turn off electricity at fuse box before proceeding.

No consumer serviceable parts. Contact factory if service is required.

For use in dry locations only.

**Retain these instructions for maintenance reference.**

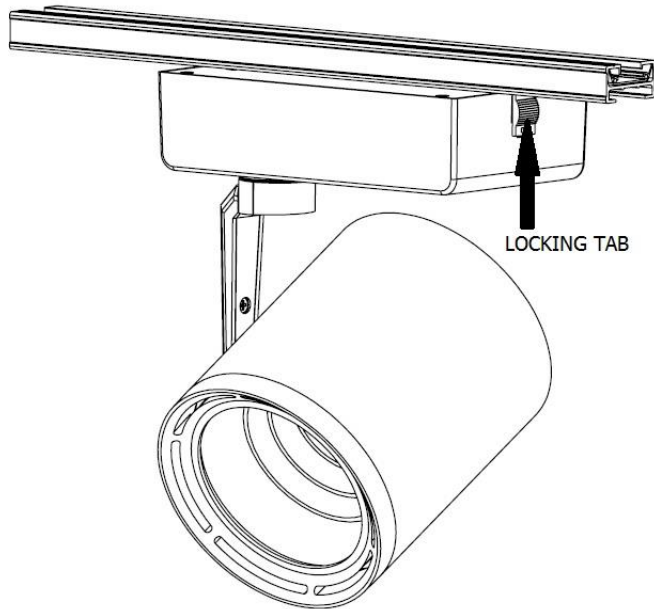

## INSTRUCTIONS FOR ATTACHING LUMINAIRE TO TRACK

1. Disengage LOCKING TAB by pulling it downward.
2. With LOCKING TAB disengaged, rotate the luminaire 90° clockwise until it is in position.
3. Release LOCKING TAB, make certain it is locked.

## INSTRUCTIONS FOR REMOVING LUMINAIRE FROM TRACK

1. Disengage LOCKING TAB by pulling it downward.
2. With LOCKING TAB disengaged, rotate the luminaire 90° counterclockwise and then remove.

## NOTE

- See below for system specific orientation.
- Consult factory for compatibility to other manufacturer's track system.
- If you encounter resistance when rotating the adaptor, check orientation of adaptor to track.

## CAUTION

RISK OF ELECTRICAL SHOCK

DAMAGE TO TRACK AND ADAPTOR IF ORIENTATION IS INCORRECT

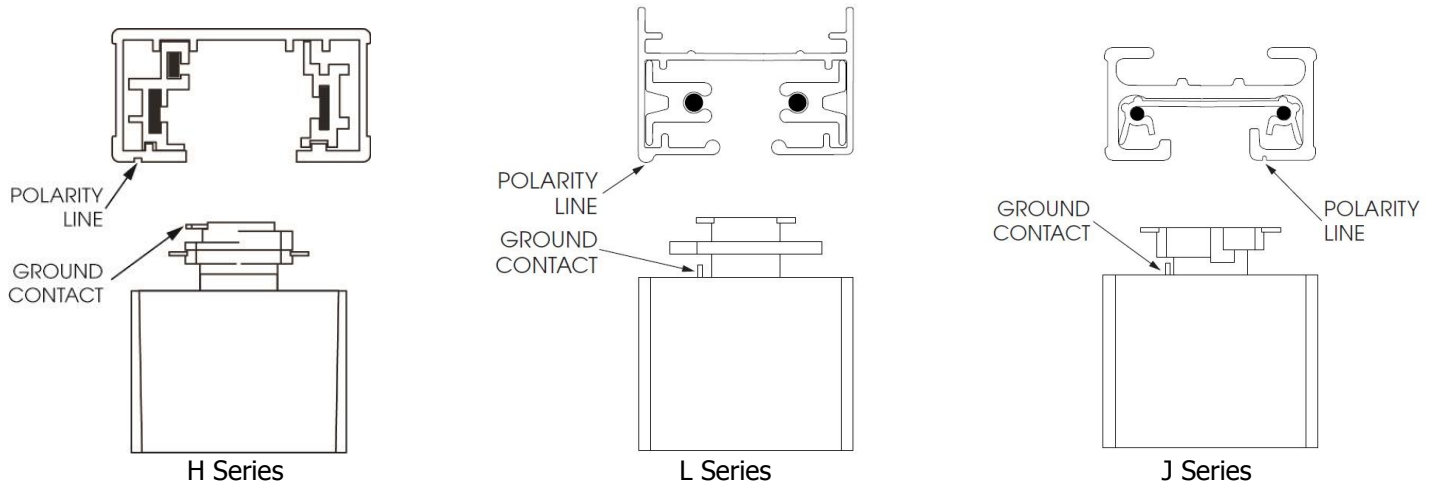

# INSTALLATION INSTRUCTIONS

L516L – PULSAR L

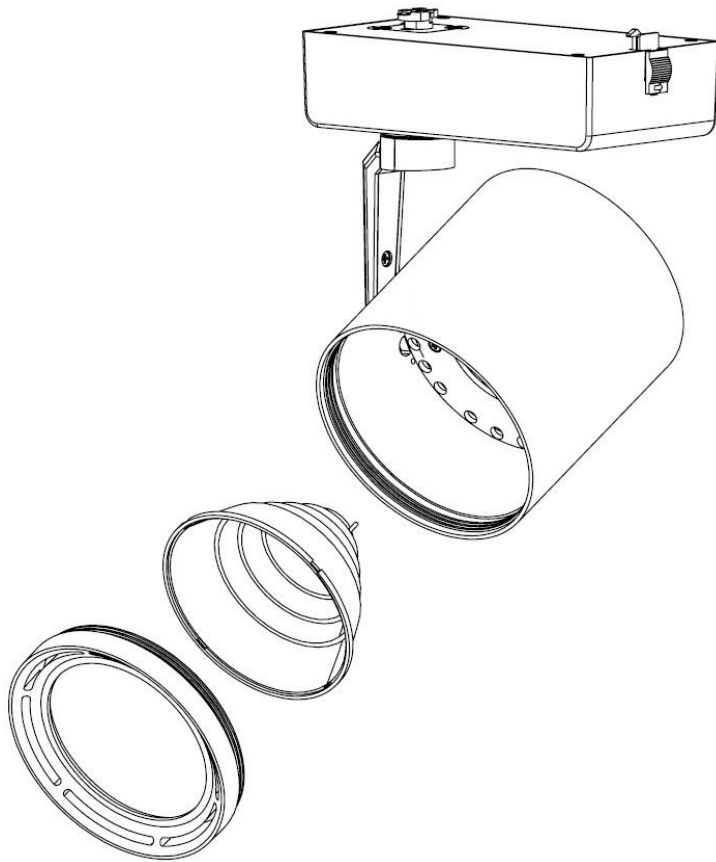

## INSTRUCTIONS FOR INSTALLING REFLECTOR

1. Remove FRONT RING from luminaire by rotating it counterclockwise.
2. Drop in REFLECTOR. Ensure it is seated properly with LED centered and two pins aligned.
3. Reattach FRONT RING by rotating clockwise.