

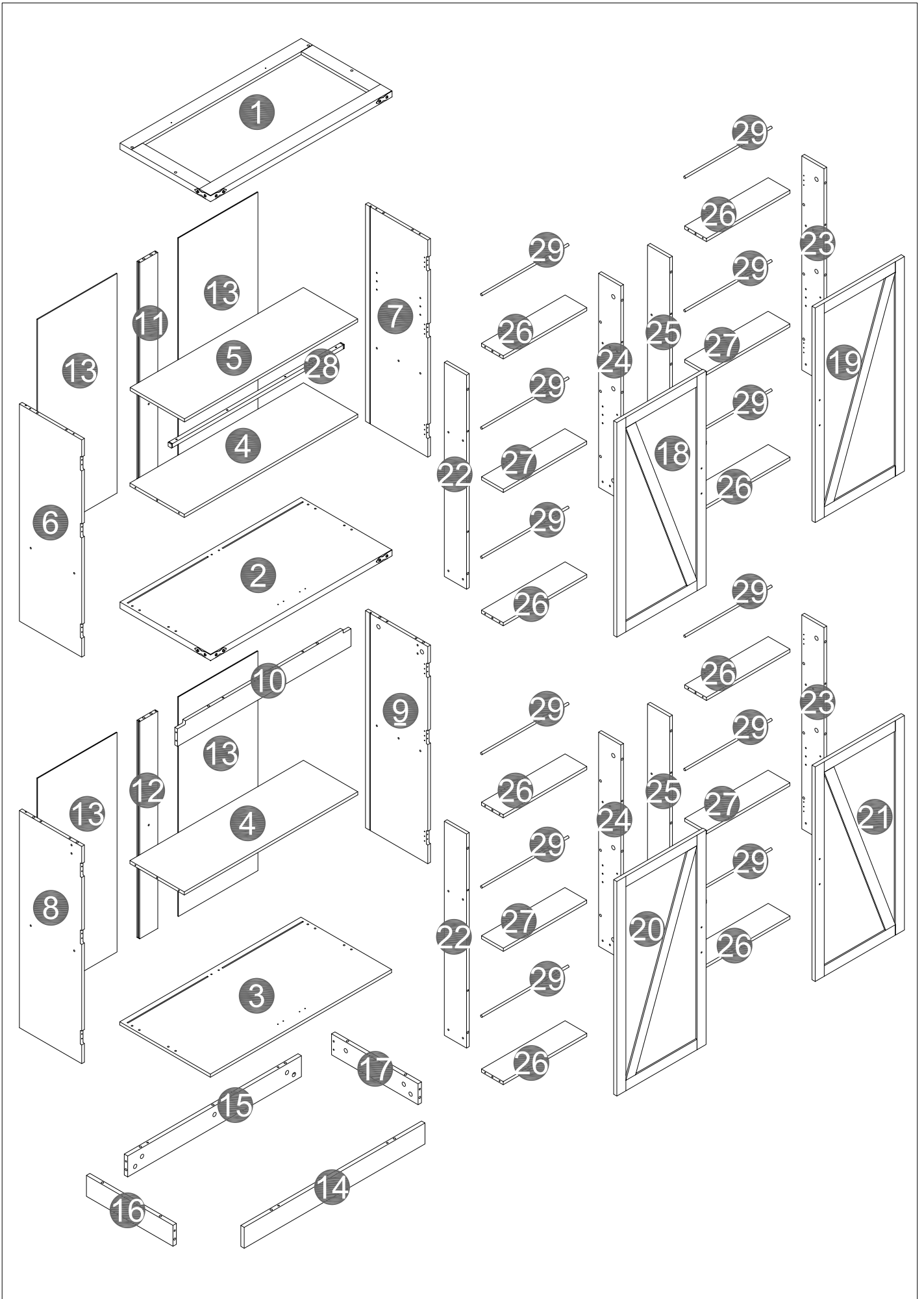

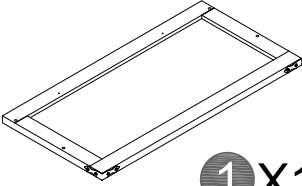

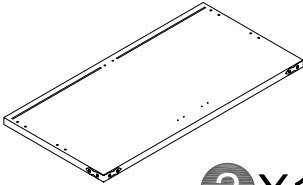

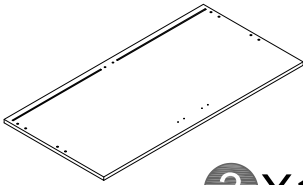

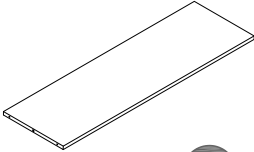
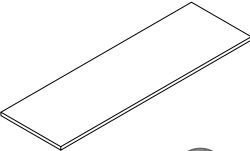
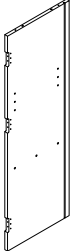
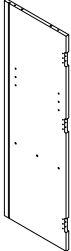
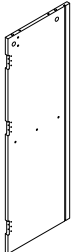

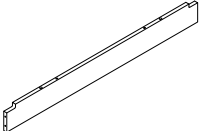

For convenience and safety,
we recommend two people to assemble.

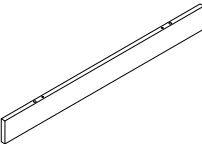
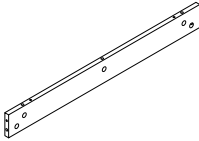
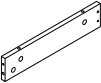
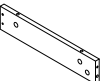
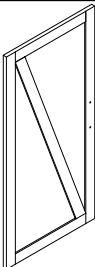
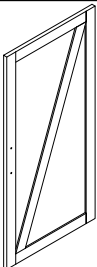
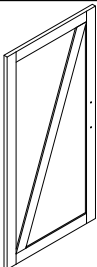
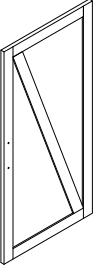

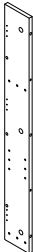
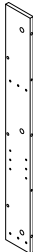
PARTS LIST

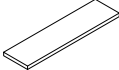
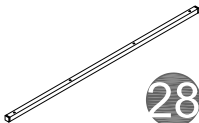
 1 X1	 2 X1	 3 X1	 4 X2
 5 X1	 6 X1	 7 X1	 8 X1
 9 X1	 10 X1	 11 X1	 12 X1
 13 X4	 14 X1	 15 X1	 16 X1
 17 X1	 18 X1	 19 X1	 20 X1
 21 X1	 22 X2	 23 X2	 24 X2
 25 X2	 26 X8	 27 X4	 28 X1
			 29 X12

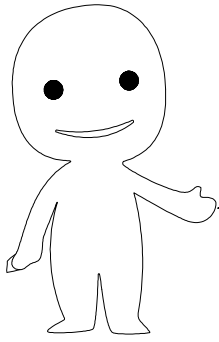

Please prepare the following tools

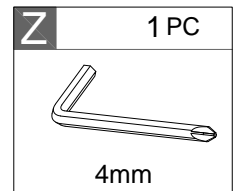
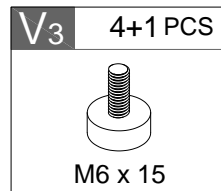
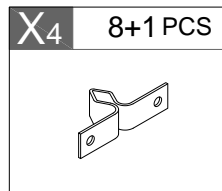
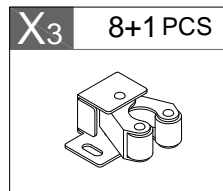
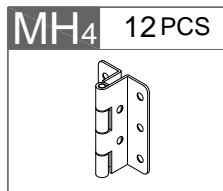
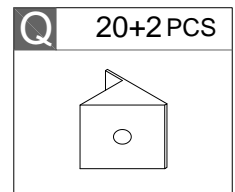
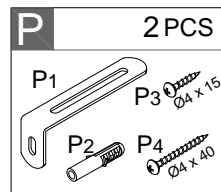
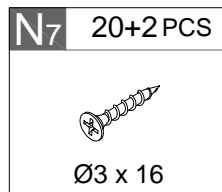
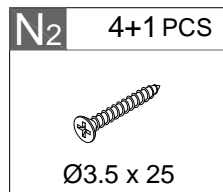
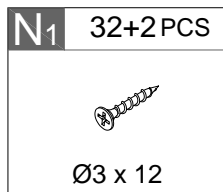
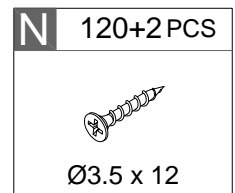
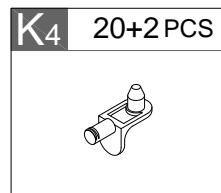
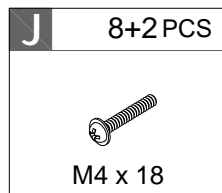
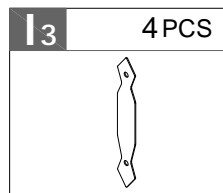
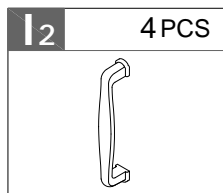
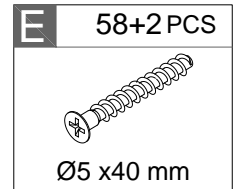
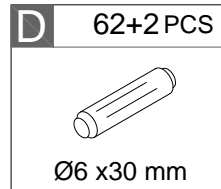
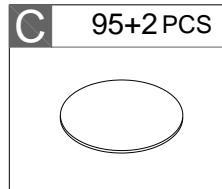
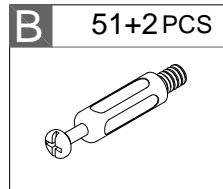
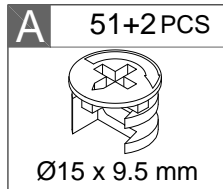
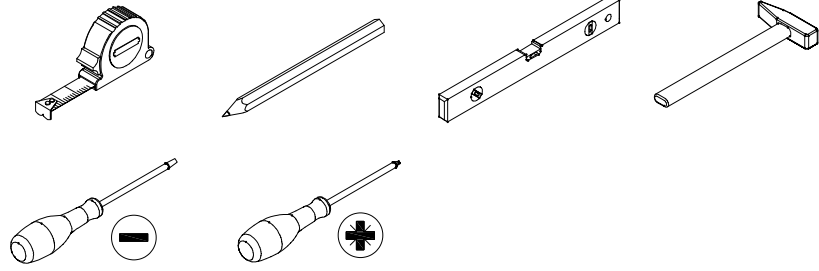

Tips: The number after "+" represents the spare hardware.

IMPORTANT NOTES:



The item you are purchasing is a large furniture product that requires a large number of components to assemble.

Please take all parts boxes out of the packaging and place them in order. So that you can follow the steps in the installation manual to find the corresponding parts box and quantity of need when installing. Please do not take too many parts to prevent the parts from scattering.

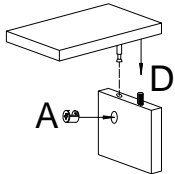
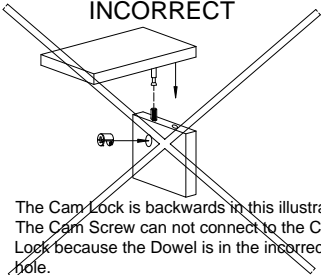
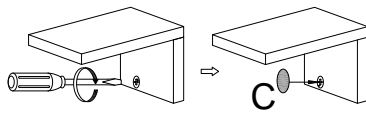
Please be patient and follow the instructions step by step for installation. If you have any problems during the installation process, you can ask our customer service to help you solve them!

Cam Lock/Dowel Placement Supplement		
<p>CORRECT 1</p>  <p>When inserting the Cam lock, make sure that the open End of the cam Lock faces the Cam Screw Entry. The Dowel will be inserted in the hole NEXT to the Cam Lock/Cam Screw hole.</p>	<p>INCORRECT 2</p>  <p>The Cam Lock is backwards in this illustration. The Cam Screw can not connect to the Cam Lock because the Dowel is in the incorrect hole.</p>	<p>3</p>  <p>To tighten, turn the Cam Lock CLOCKWISE until the arrow or "△" signs point AWAY from the connected board.</p> <p>*NOTE: DO NOT USE AN AUTOMATIC SCREWDRIVER TO TIGHTEN CAM LOCKS, DO NOT OVER-TIGHTEN.</p>

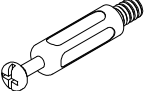
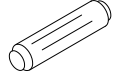
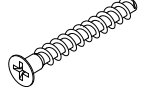
1

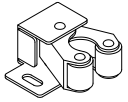
B	2 PCS	D	6 PCS	E	12 PCS	N₁	4 PCS	X₃	2 PCS
									

Note the gap orientation.

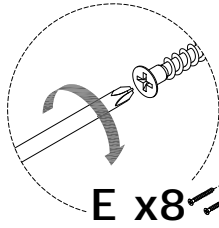

E x8



10

D x2

4

9

Note that the part with holes is at the lower side.



First, insert wooden dowel **D** into the designated side hole, followed by the installation of other components.



D x4

3

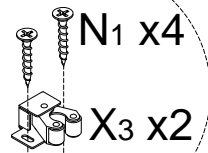

N₁ x4

X₃ x2



B x2

3

E x4

2

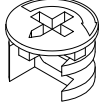
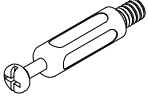
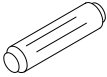
A	4 PCS	B	4 PCS	D	4 PCS
					

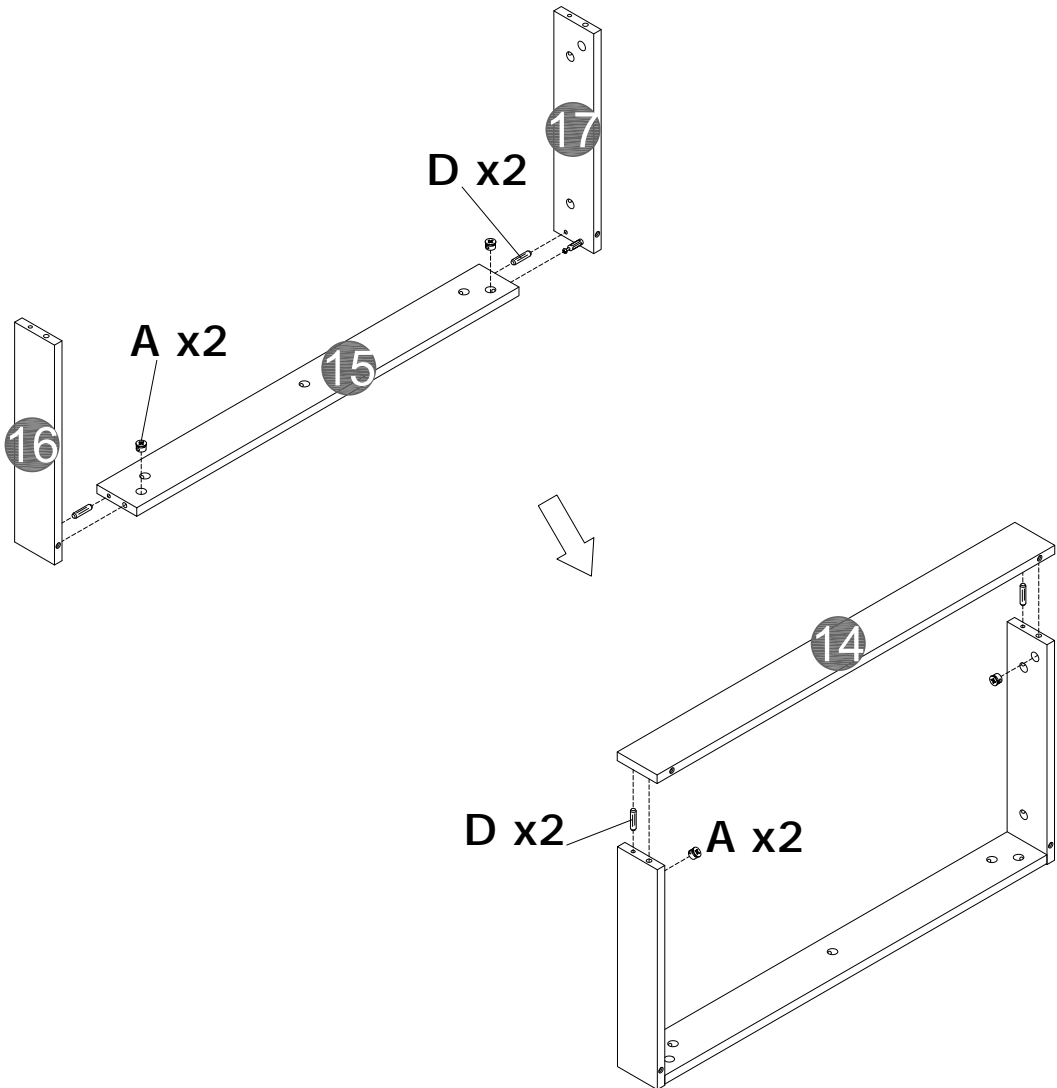
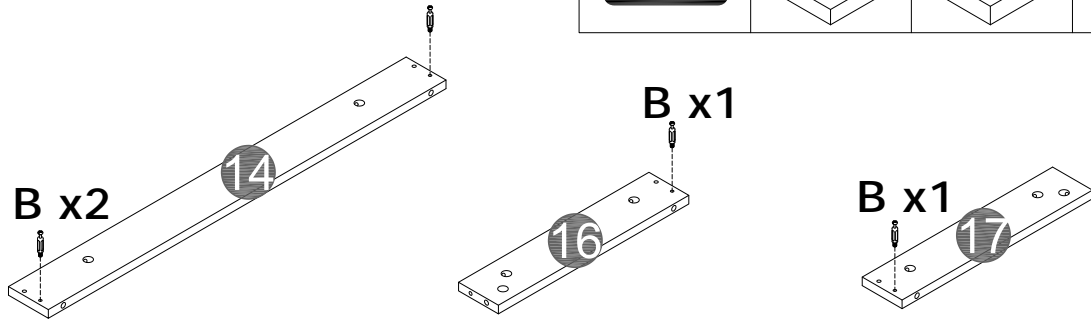
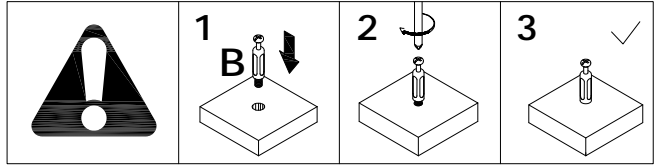



A	9 PCS	B	9 PCS	D	4 PCS

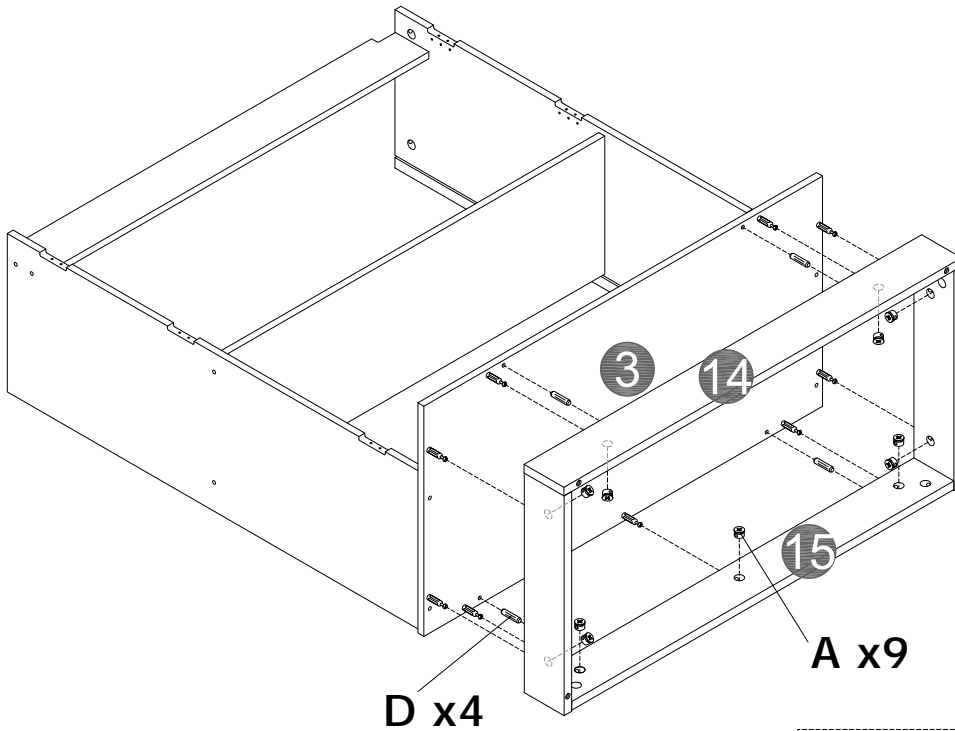
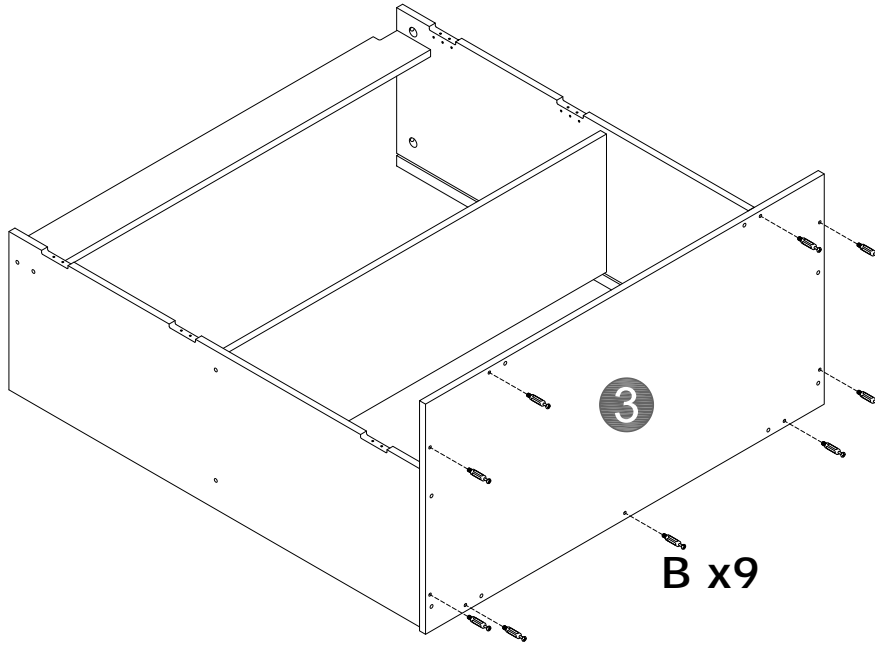

 Note the front and rear sides of the bottom frame.

4

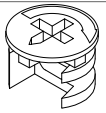
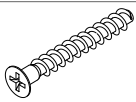
A	2 PCS	E	1 PC
			

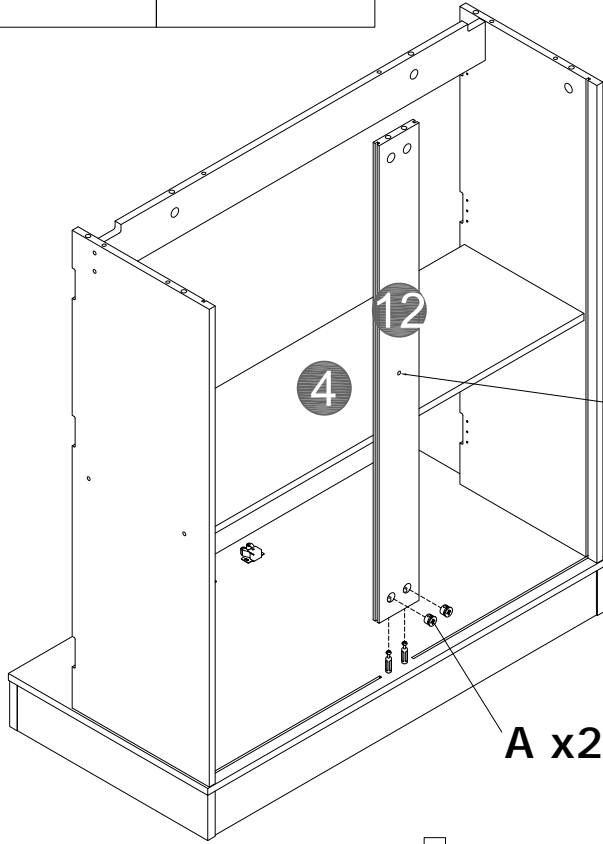

Note: The hole positions on Board 12 correspond to those on Board 4.

A x2

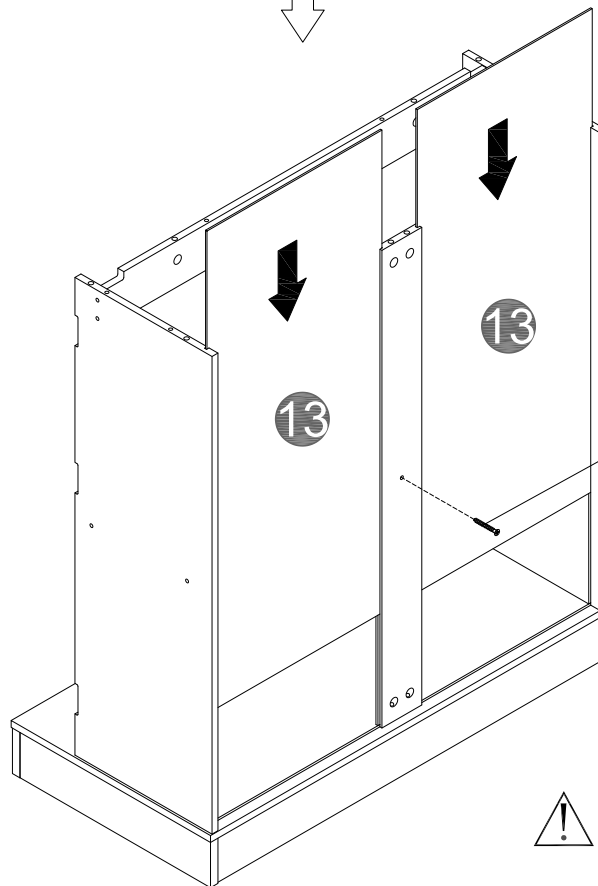



E x1

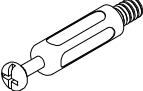
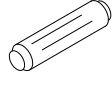
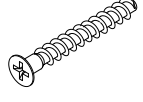

Ensure the back board is inserted into the slot.

5

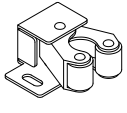
B	2 PCS	D	6 PCS	E	8 PCS	N₁	4 PCS	X₃	2 PCS
									

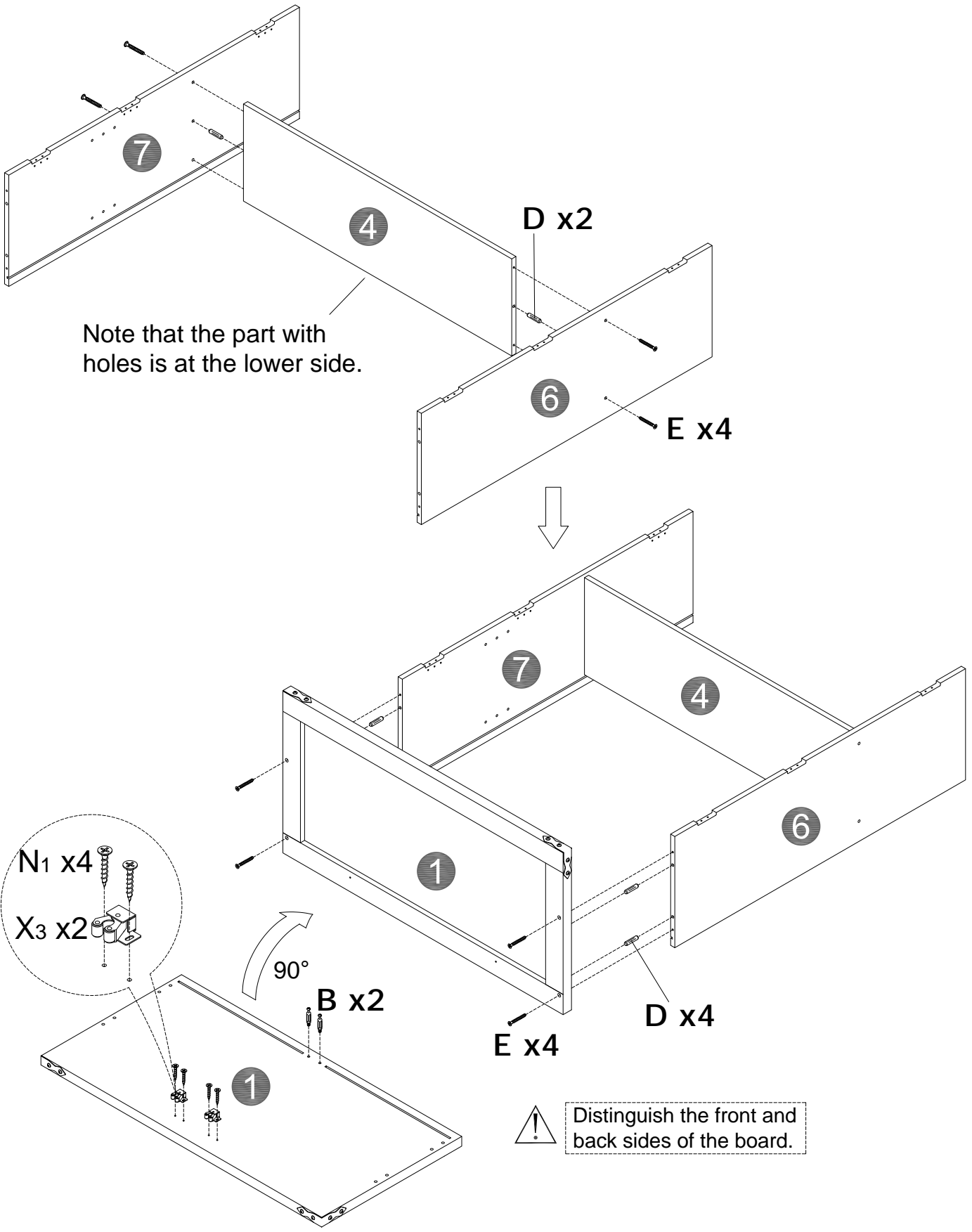

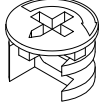
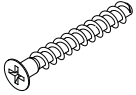

A	2 PCS	E	1 PC
			

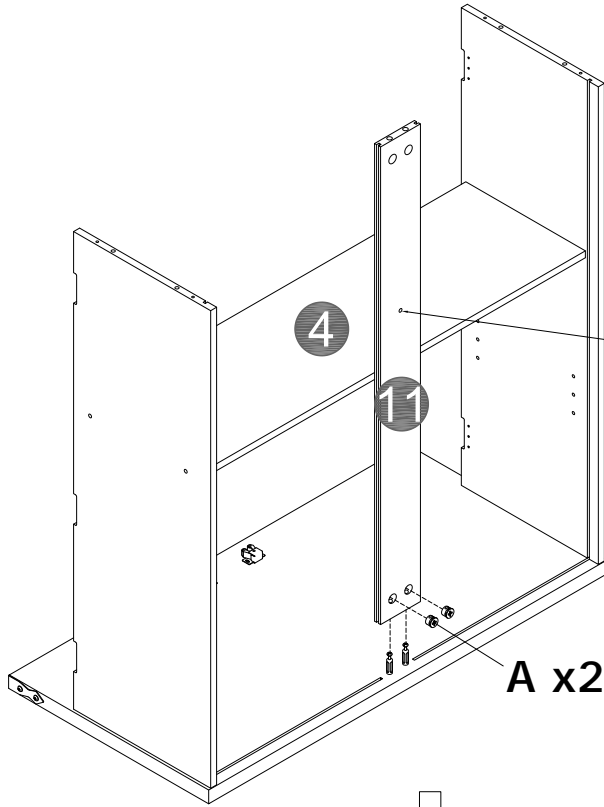

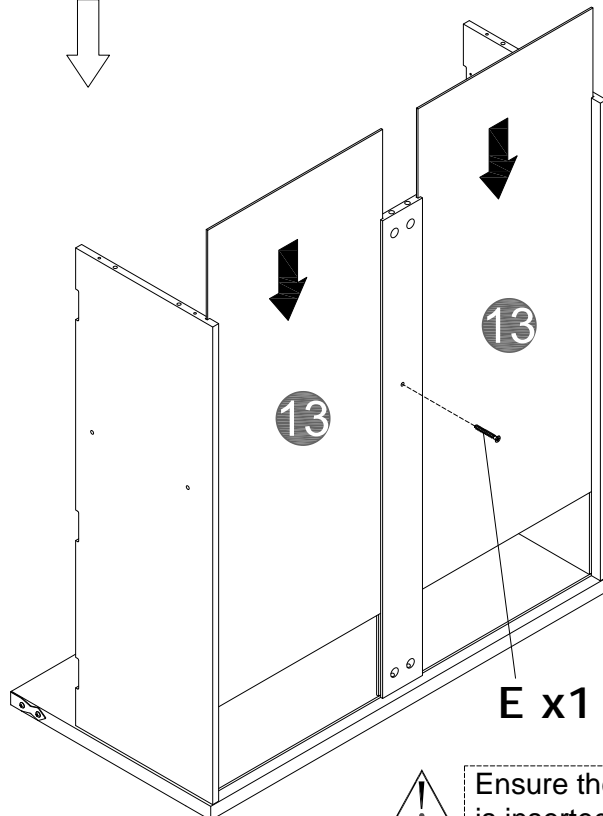

Note: The hole positions on Board 11 correspond to those on Board 4.

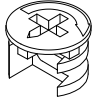
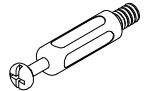
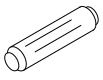
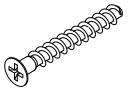

Ensure the back board is inserted into the slot.

7

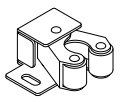
A	2 PCS	B	10 PCS	D	4 PCS	E	4 PCS	N₁	8 PCS	X₃	4 PCS
											

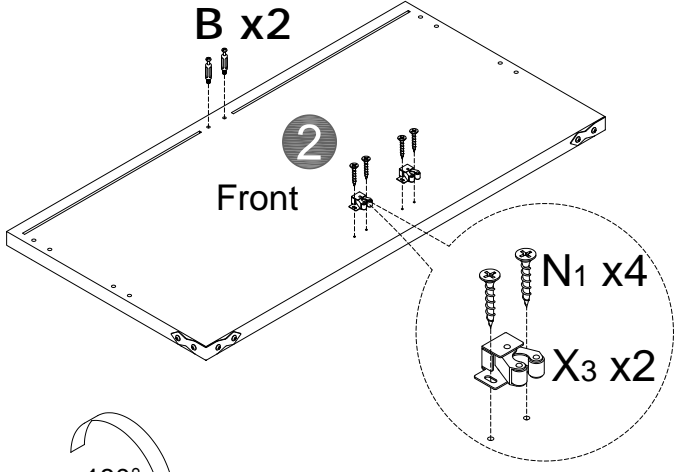

180°

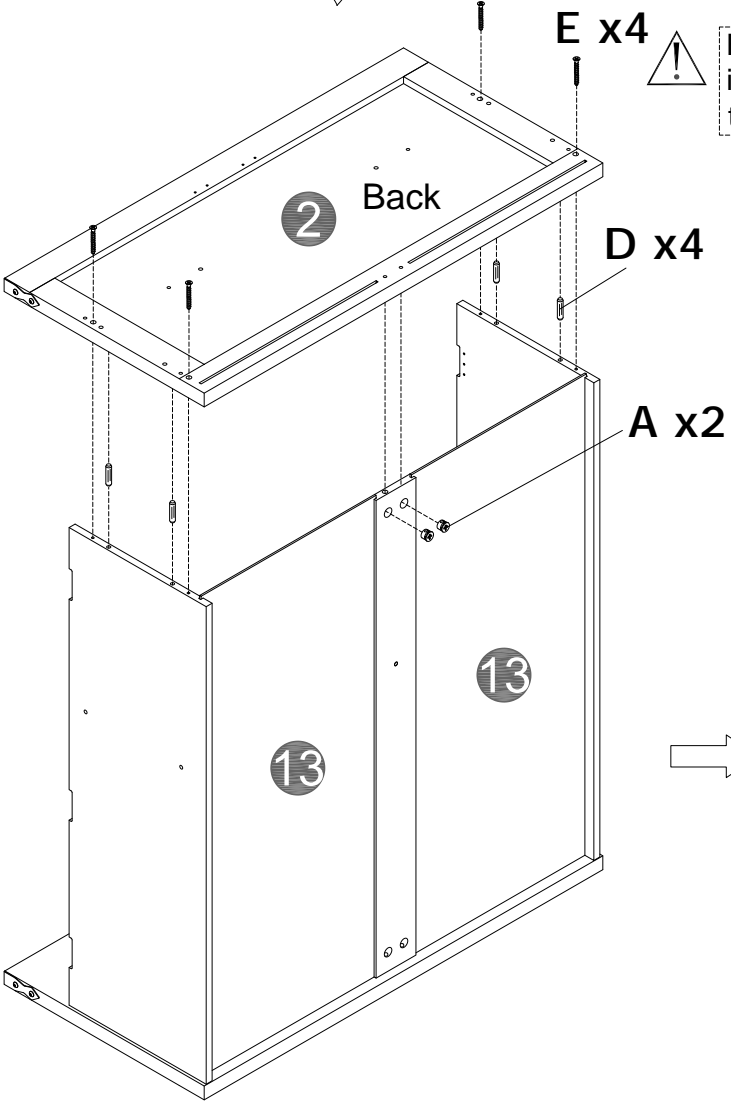

! Ensure the back board is inserted into all four slots, then tighten the screws.

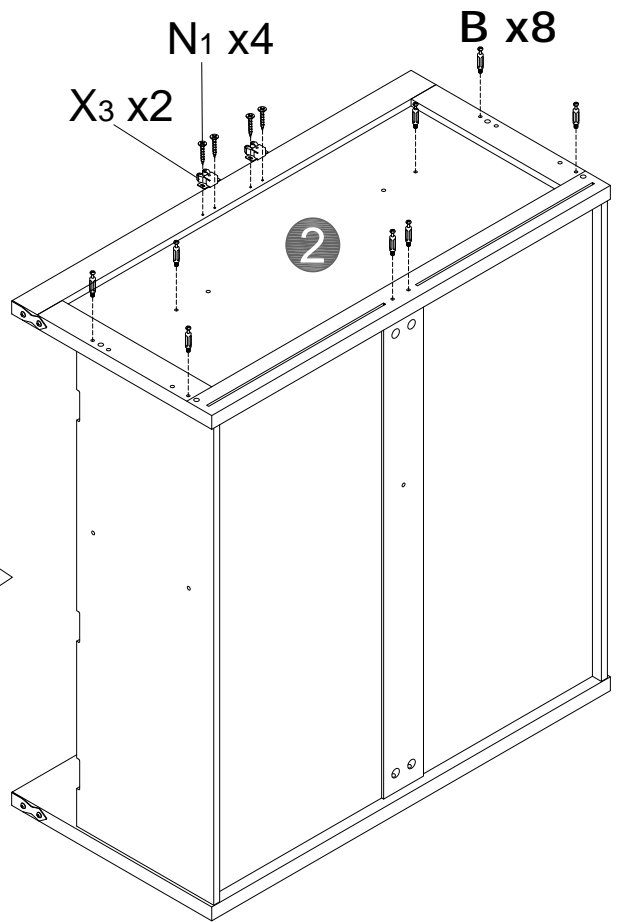



A	8 PCS	D	6 PCS	V ₃	4 PCS

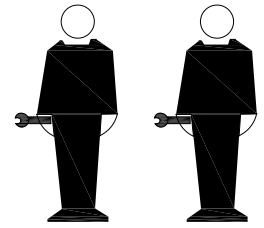

This step requires two people to complete

This step is difficult to install.
Note: Make sure that board 13 is inserted into the groove of board 2 and then fasten A.

use foam to cushion the bottom of the backplane.

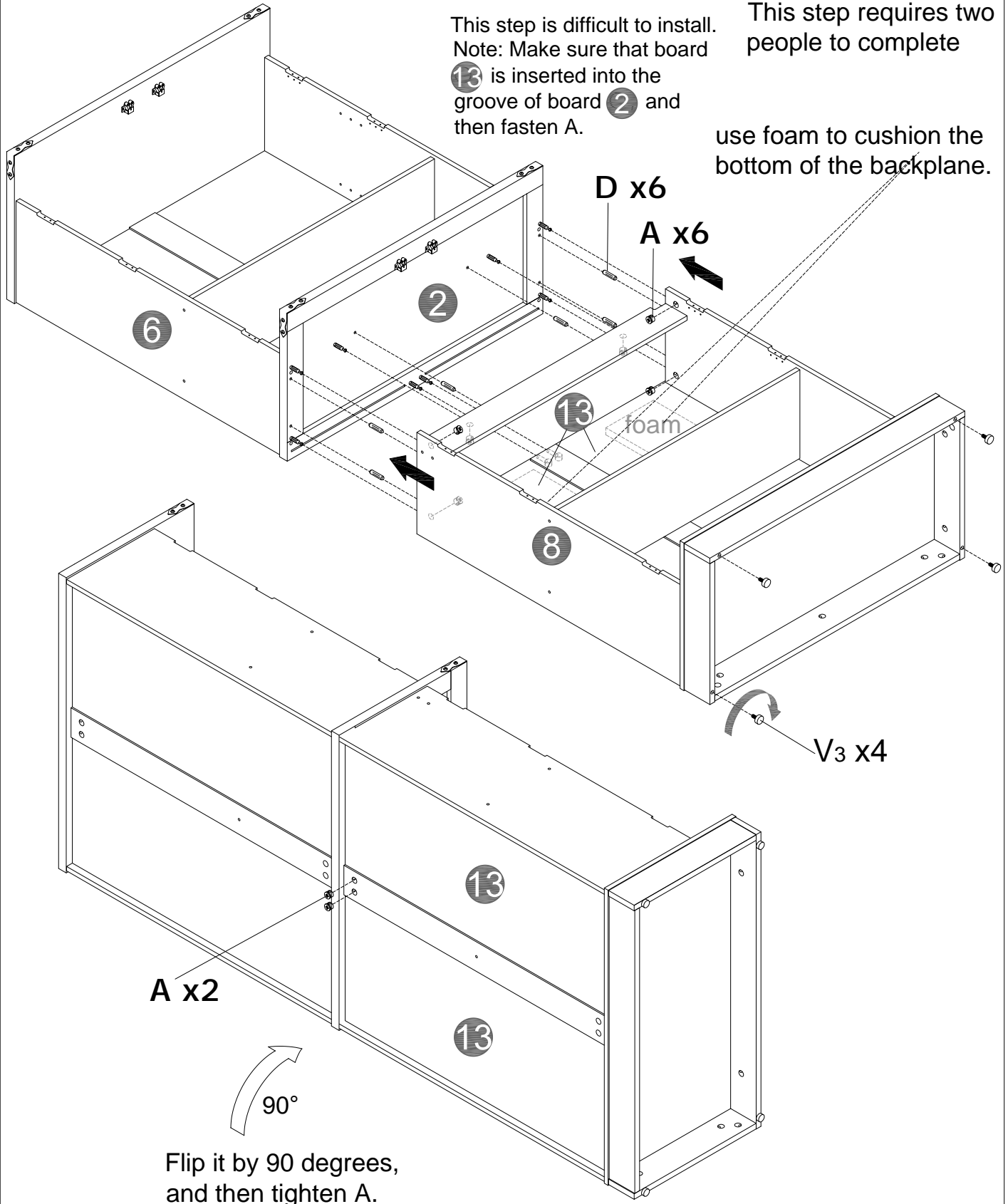



Flip it by 90 degrees,
and then tighten A.

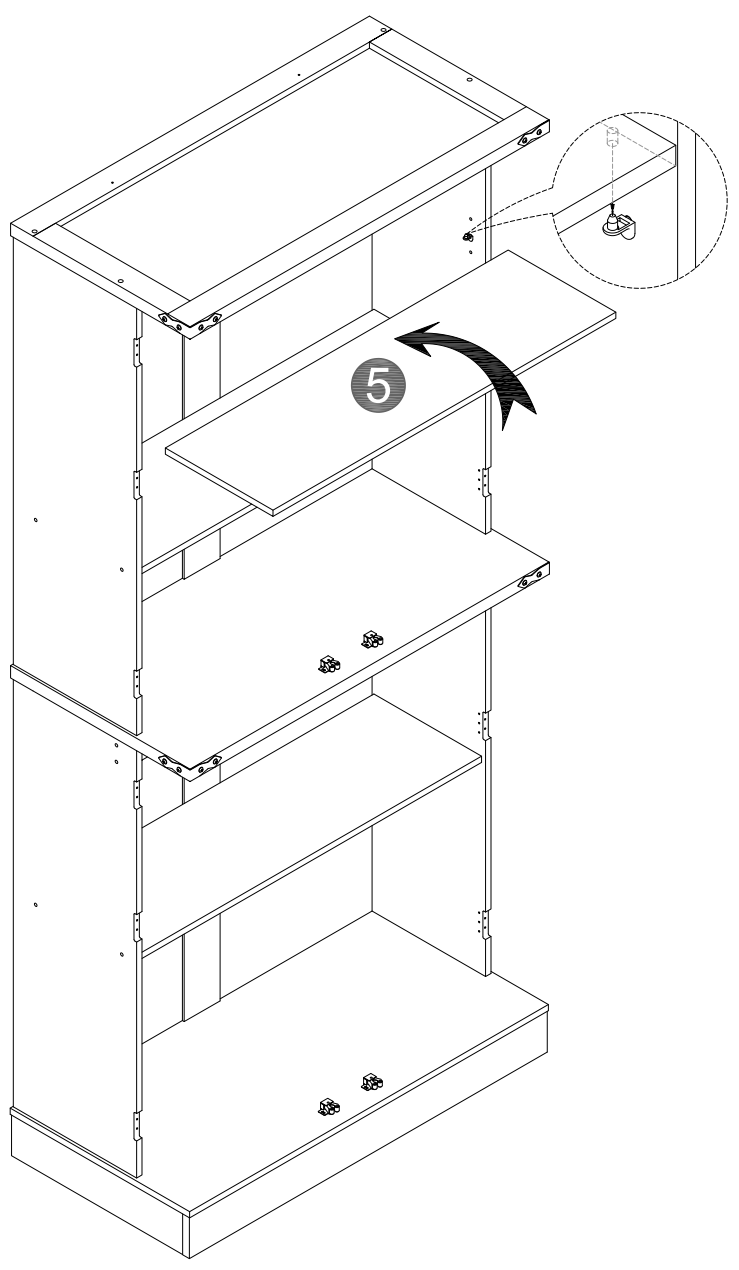
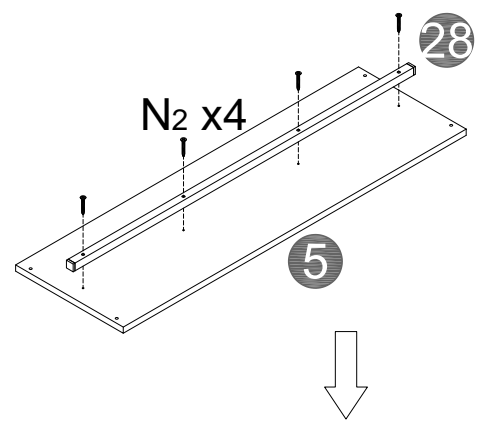
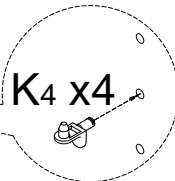
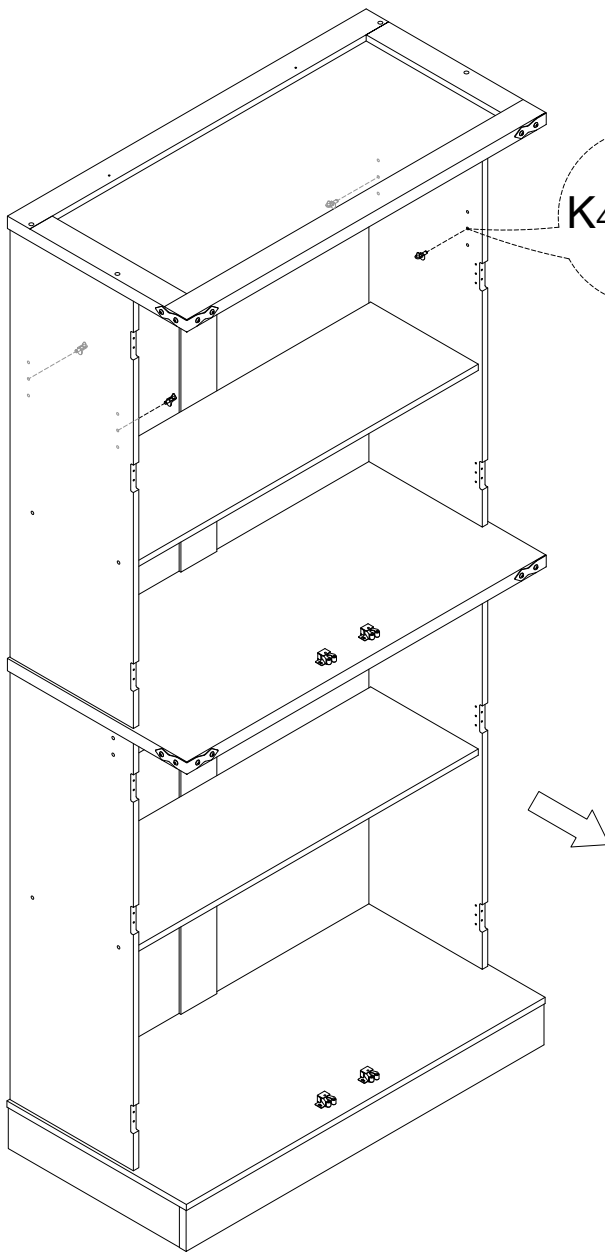

K4	4 PCS	N2	4 PCS



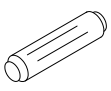
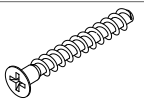

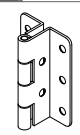

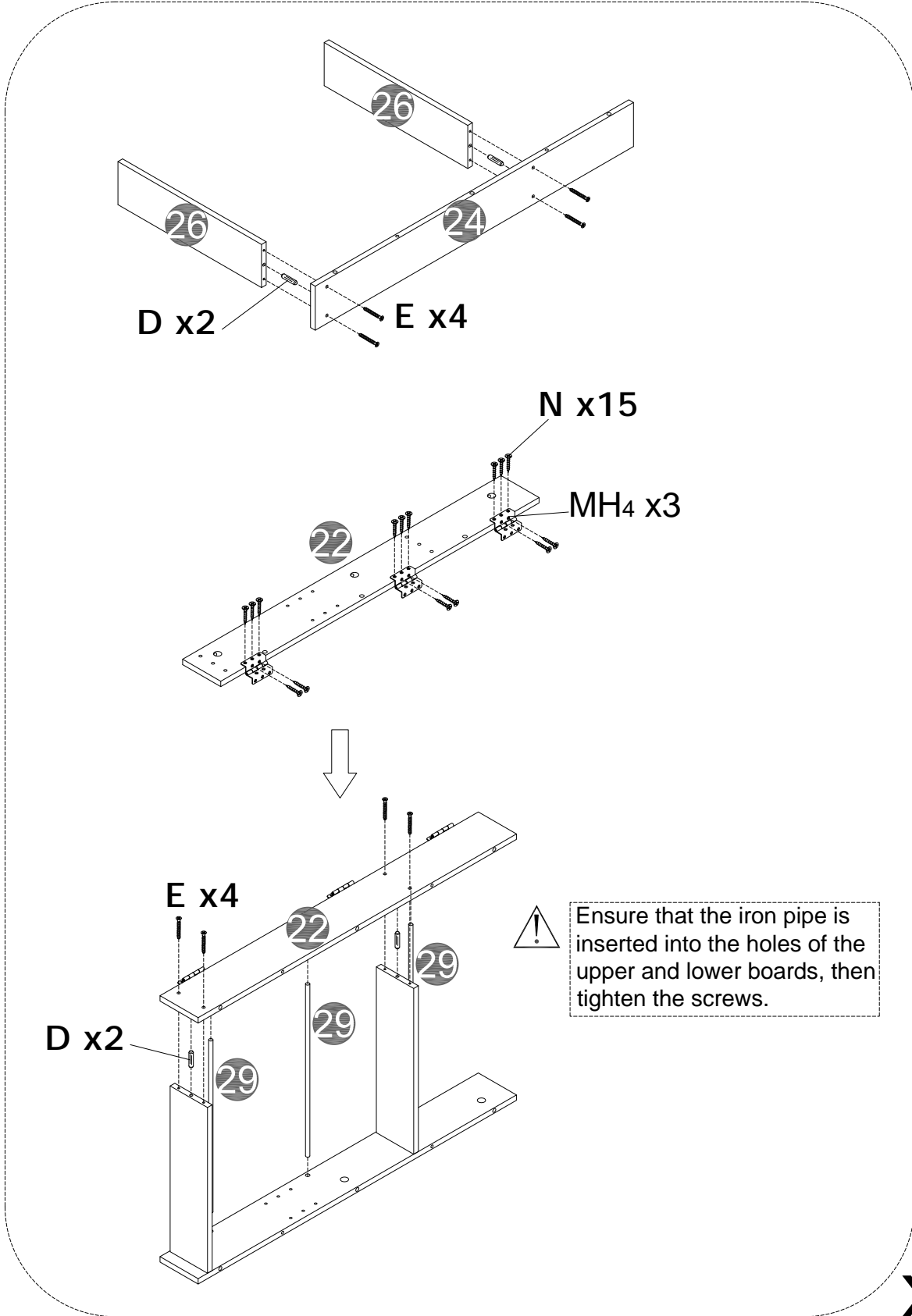

10

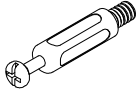
D	8PCS	E	16PCS	N	30PCS	MH4	6PCS
							



1 1

B	12 PCS	I₂	2 PCS	I₃	2 PCS	J	4 PCS	N₁	8 PCS	X₄	4 PCS
											

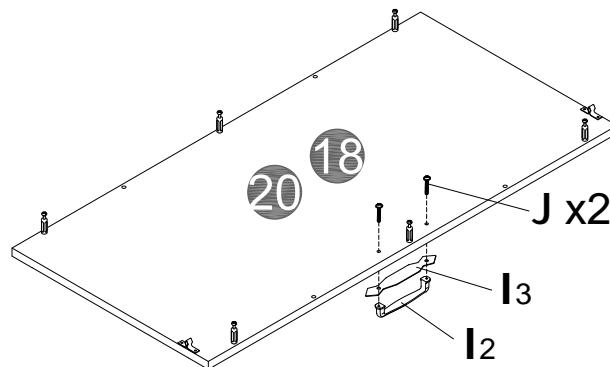
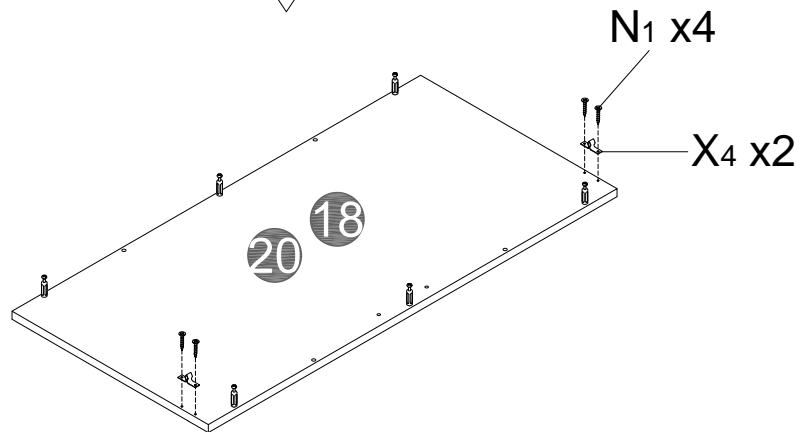
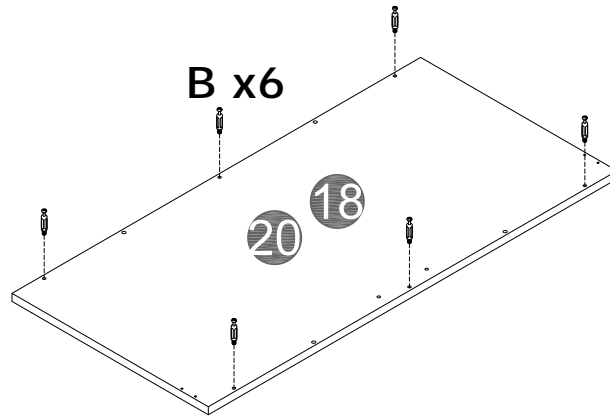

12

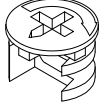
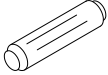

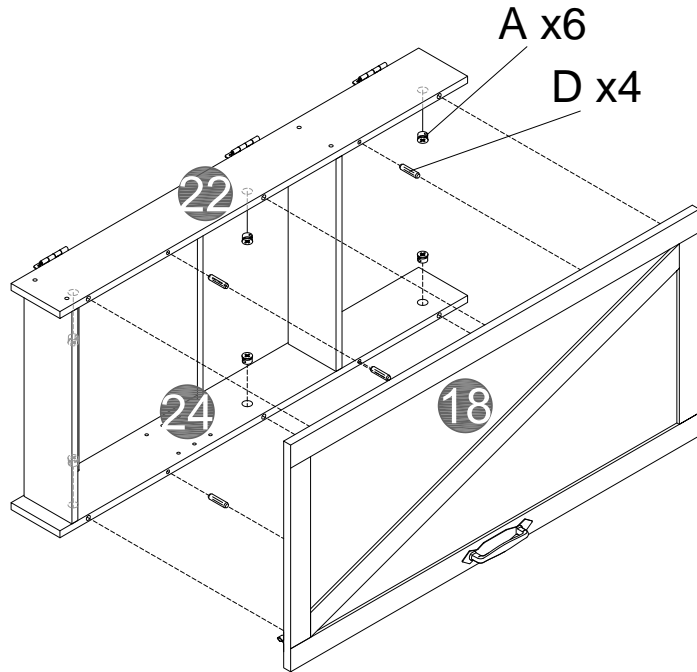
A	12 PCS	D	8 PCS
			

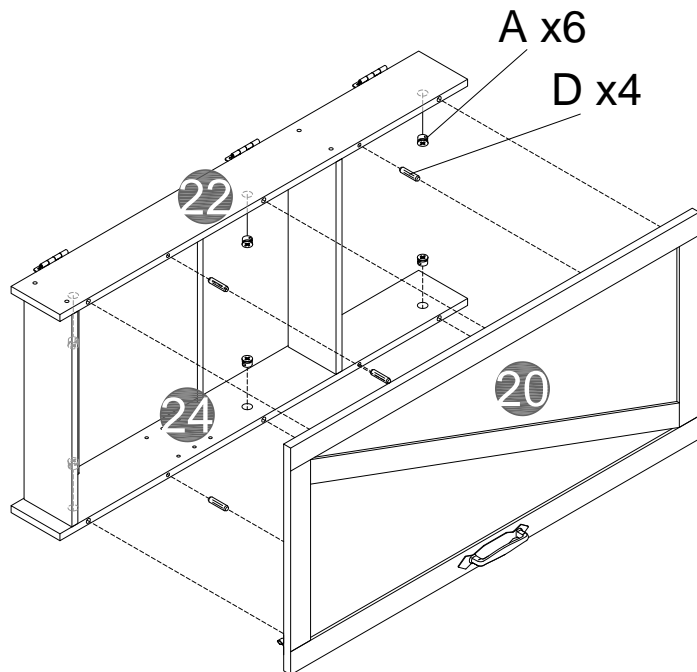

Note: Board 24 and the door board handle must be on the same side.

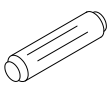
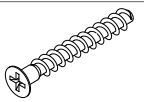

13

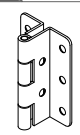
D	8PCS	E	16PCS	N	30PCS	MH4	6PCS
							

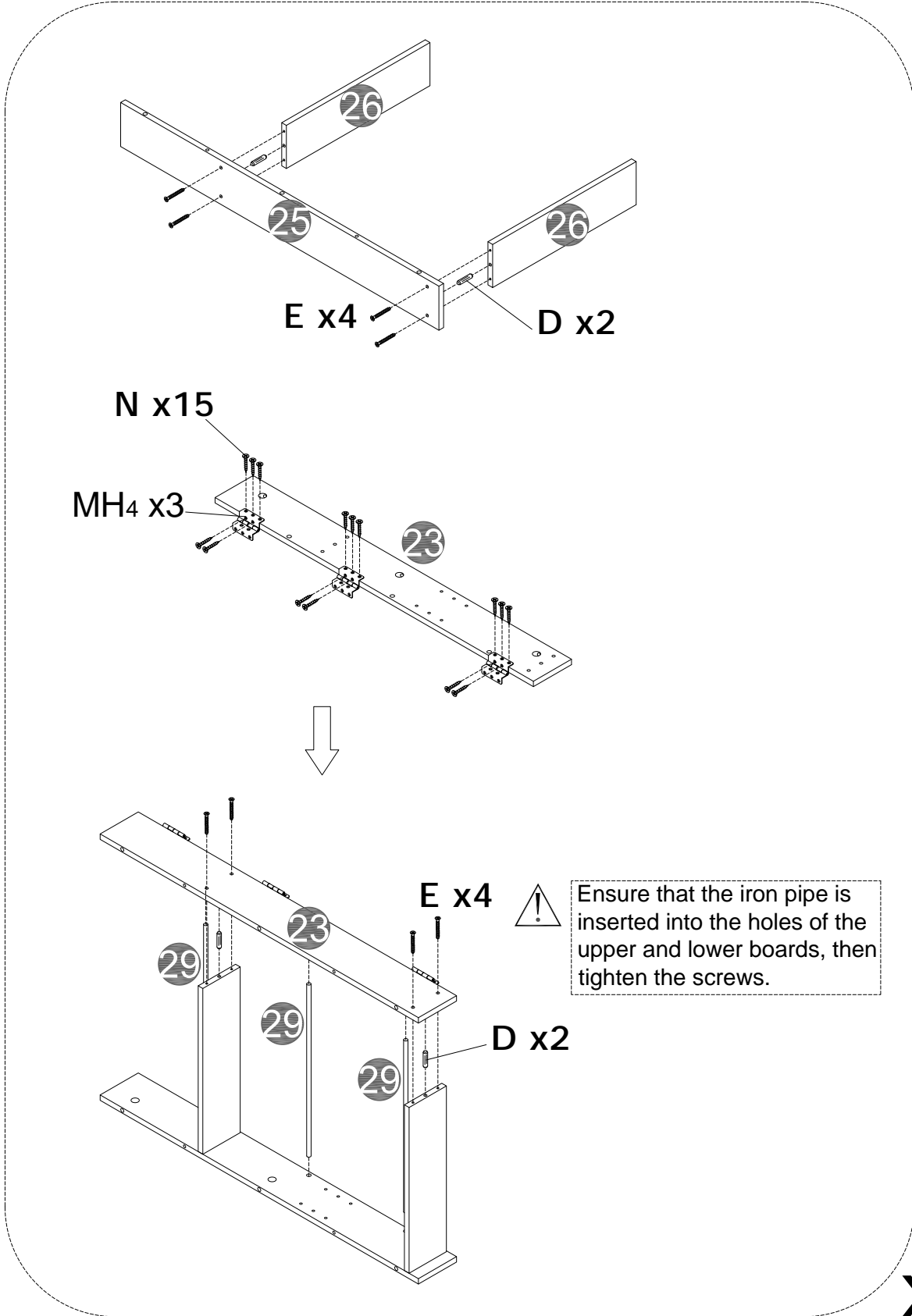

14

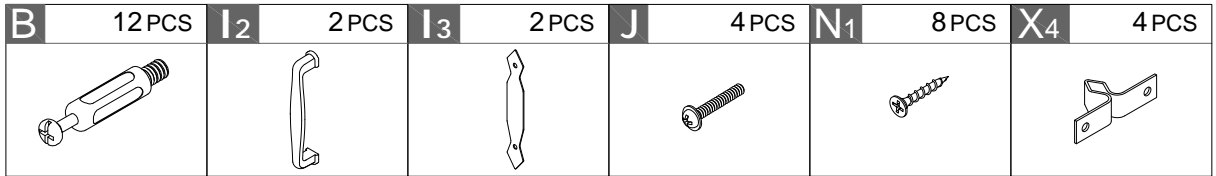
B	12 PCS	I₂	2 PCS	I₃	2 PCS	J	4 PCS	N₁	8 PCS	X₄	4 PCS
											

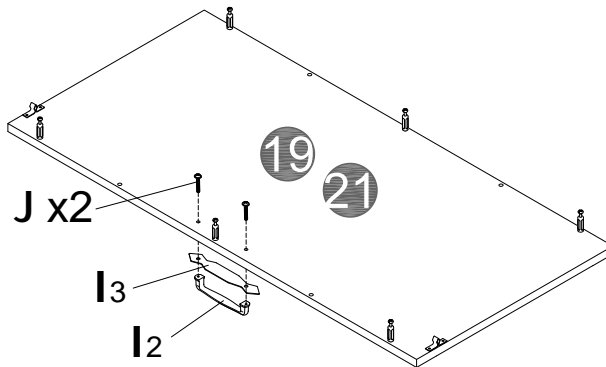
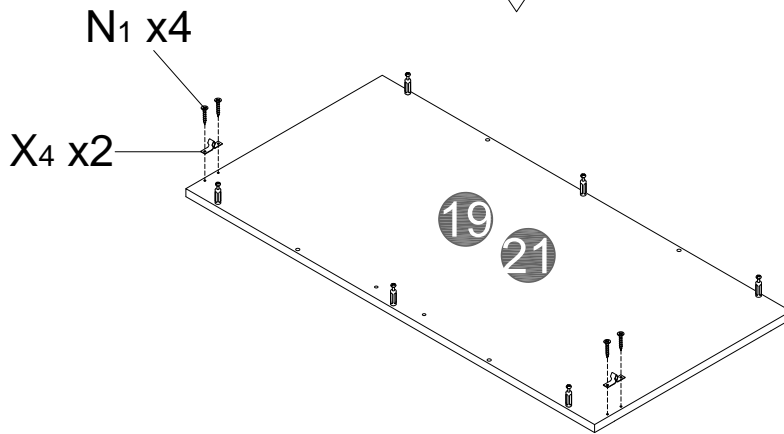
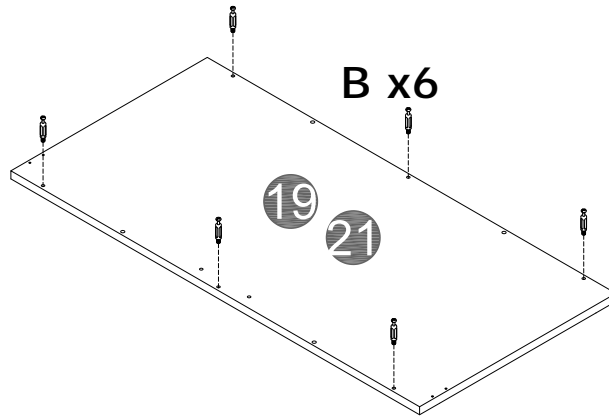

15

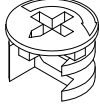
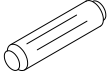
A	12 PCS	D	8 PCS
			

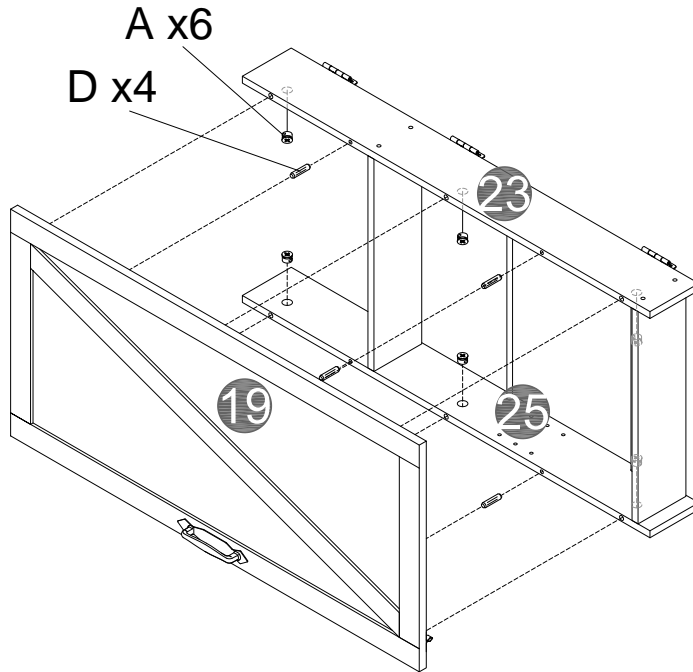

Note: Board **25** and the door board handle must be on the same side.

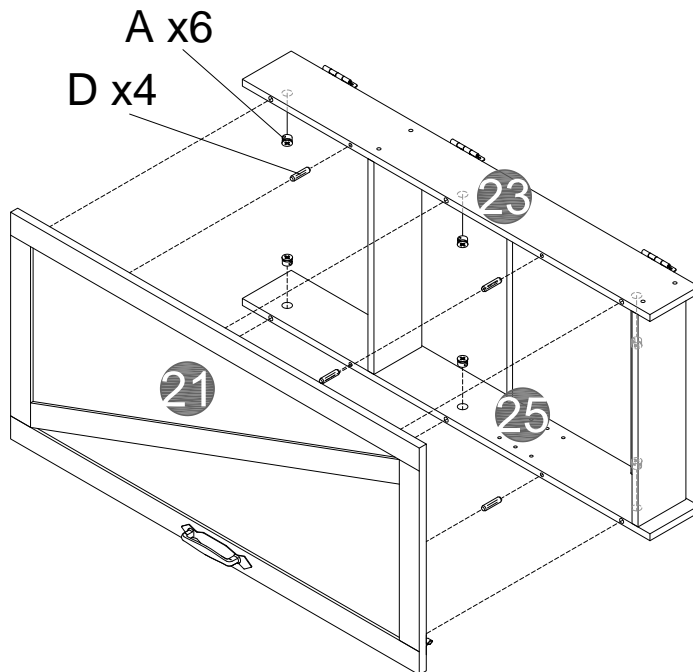

16

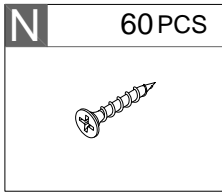

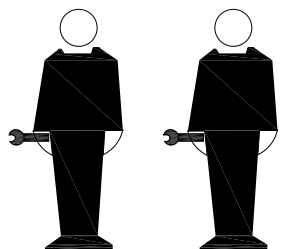
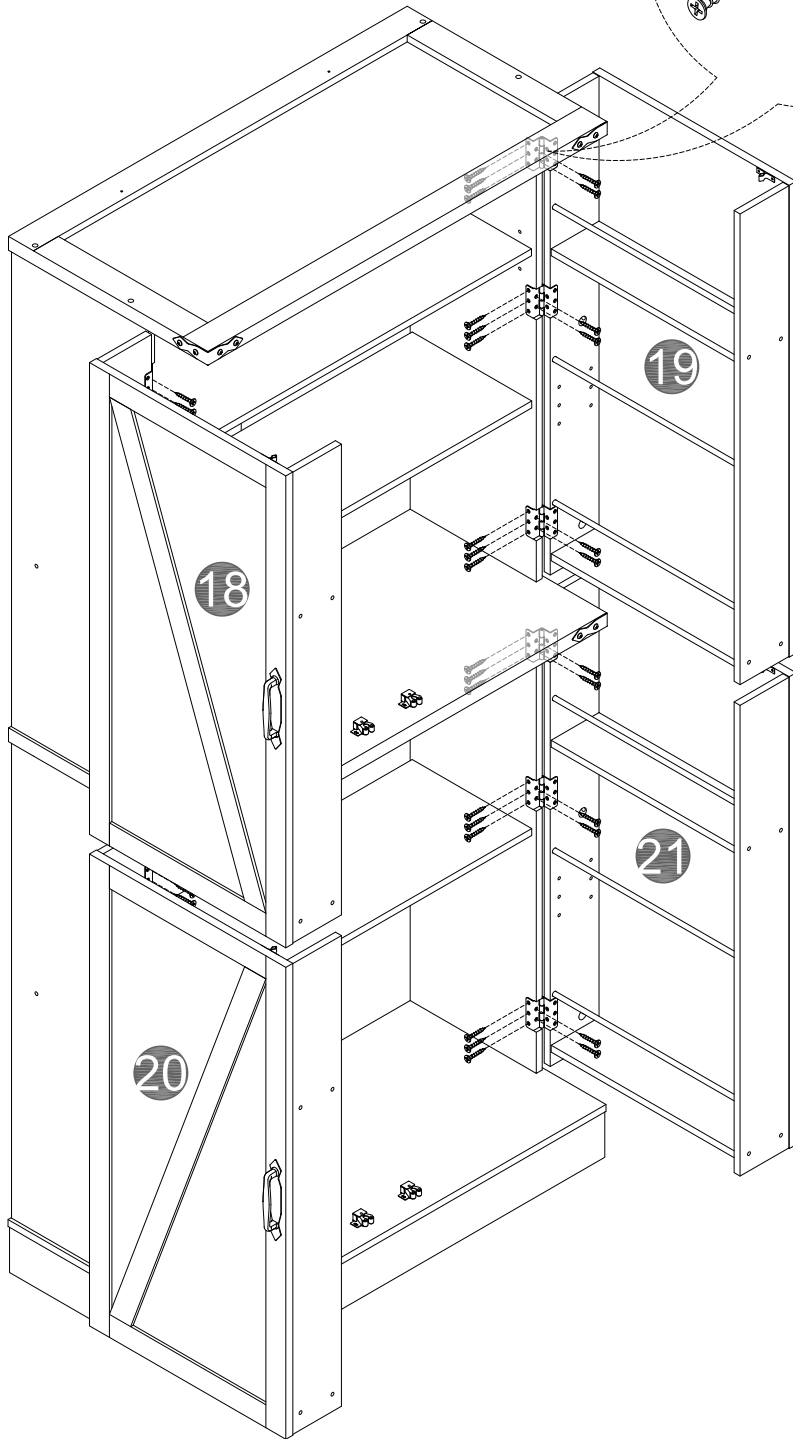
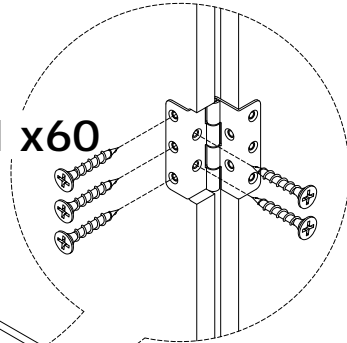

N x60



This step requires two people to complete

17

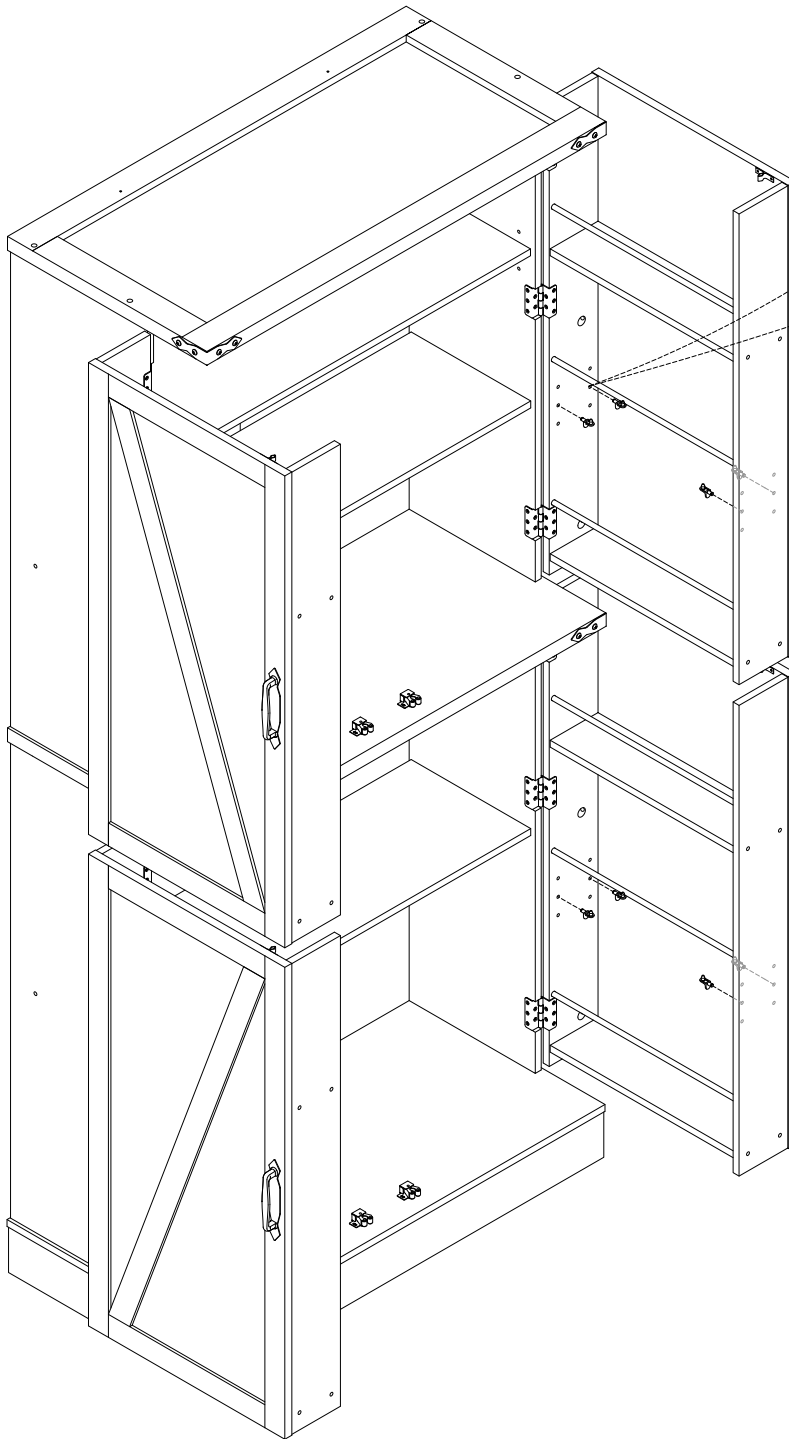
K4 16PCS



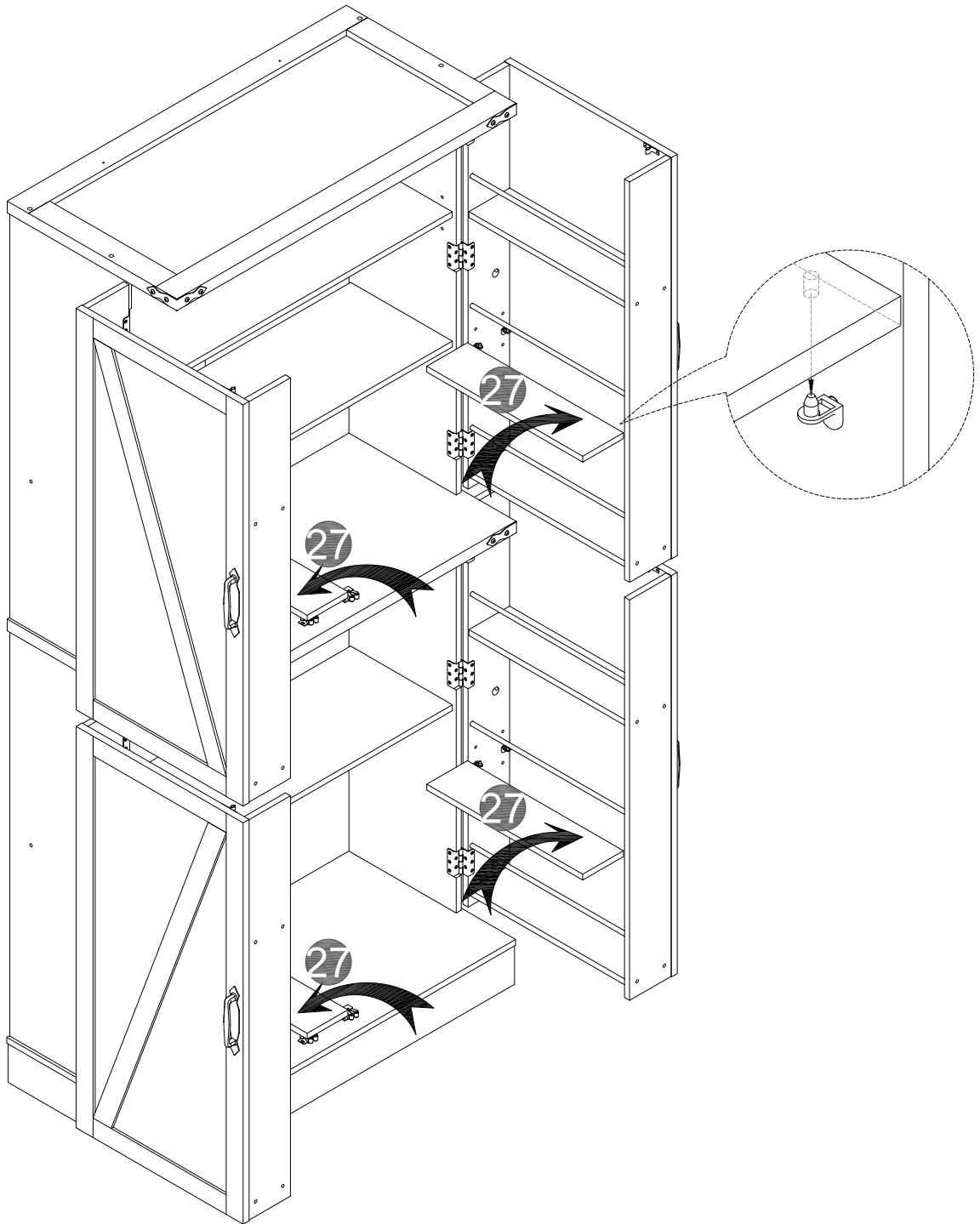

K4 x16

18

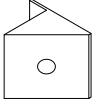

19

Q	20 PCS	N7	20 PCS
			

Installing back board fasteners can improve the overall stability of the furniture. It ensures the verticality of the furniture and that the door boards are level, so that the gaps are uniform.

Also, you can adjust the level of the cabinet by using the adjustable feet at the bottom of the furniture to make the gaps between the cabinet door boards even.

During the adjustment process, you should first place the furniture in the position where it is needed. Otherwise, when you move it to that position after adjustment, you may encounter an uneven floor.

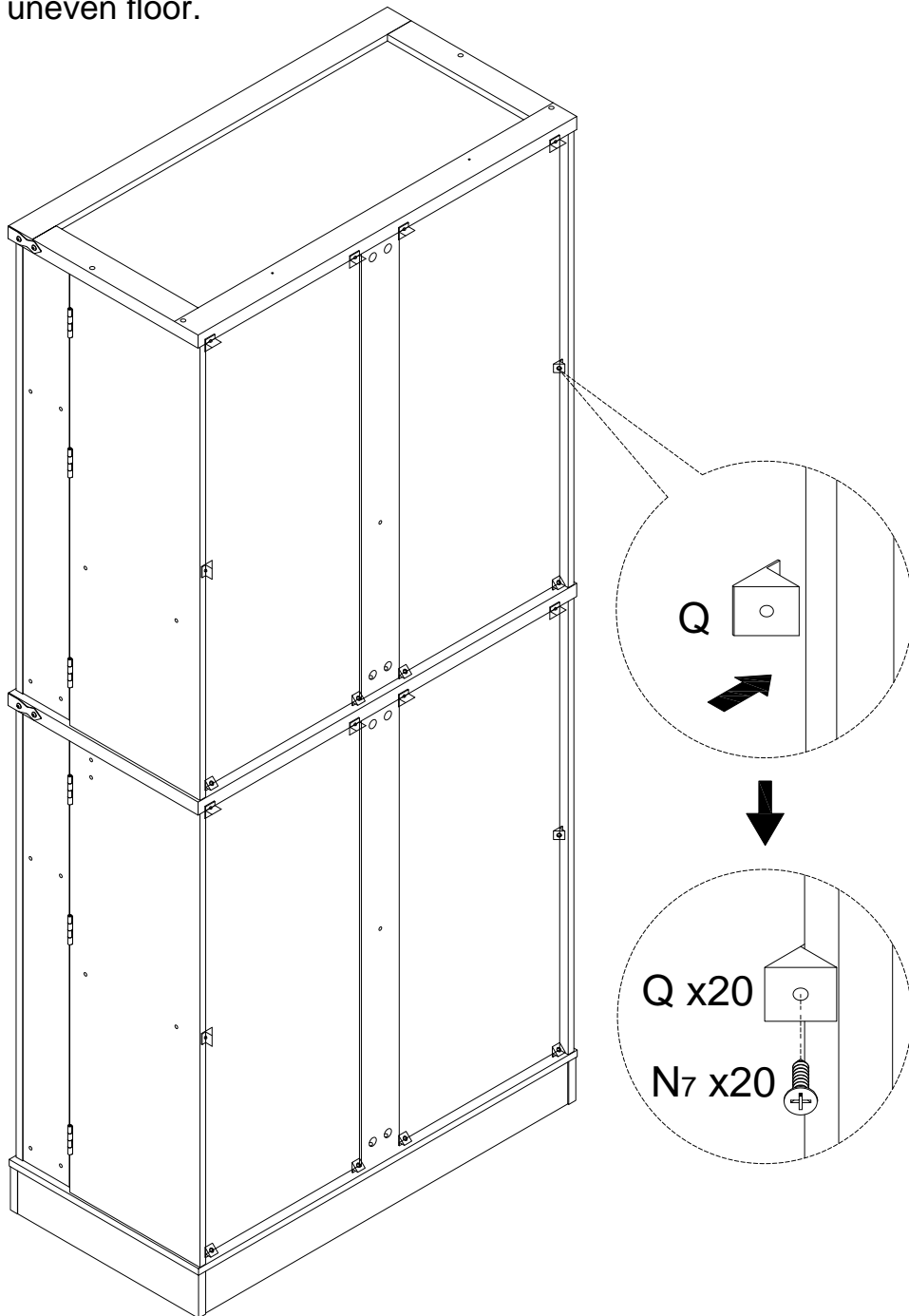

20

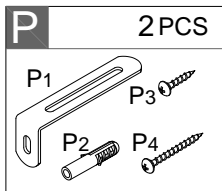

 **Warning:** If you overturn the furniture, it may cause serious or fatal crushing injuries. We have a wall connection device attached, please use it to hold the furniture following these instructions.

1. Mark the corresponding hole positions where you want to place the furniture;
2. Use a impact drill to drill holes and pay attention to avoid wires and water pipes;
3. Knock the expansion pipes into the wall holes;
4. Place the furniture in the corresponding position and tighten the wall connection device with screws.

