

ASSEMBLY INSTRUCTIONS

- Wooden Love Seat

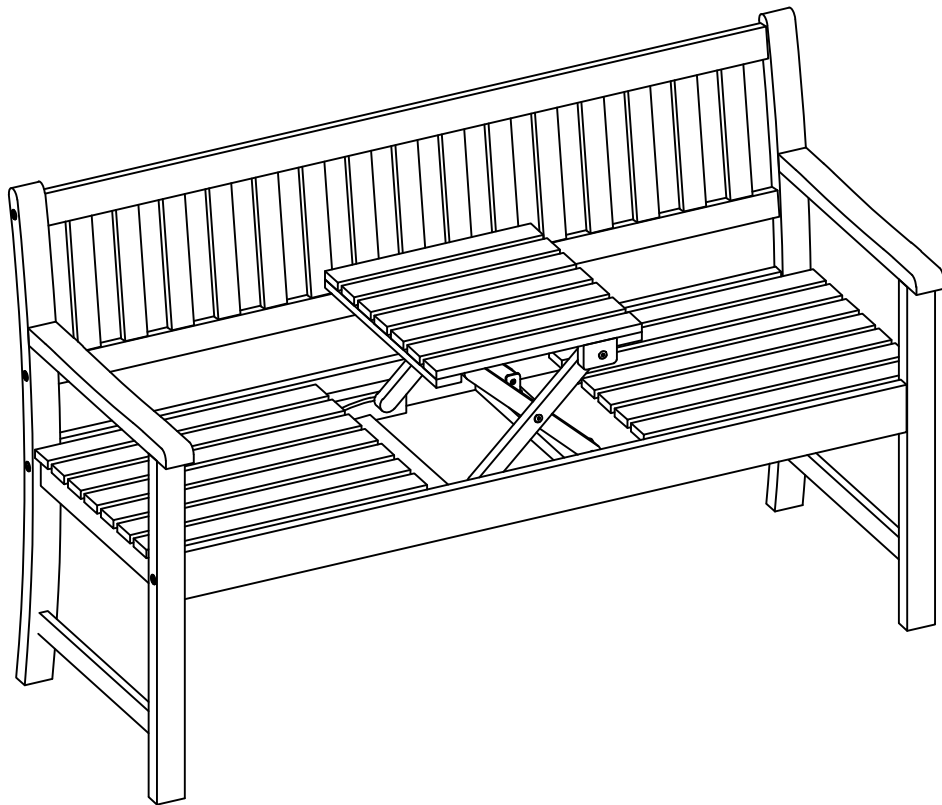

Parts

Check and make sure you get the components on the list, contact us for any missing

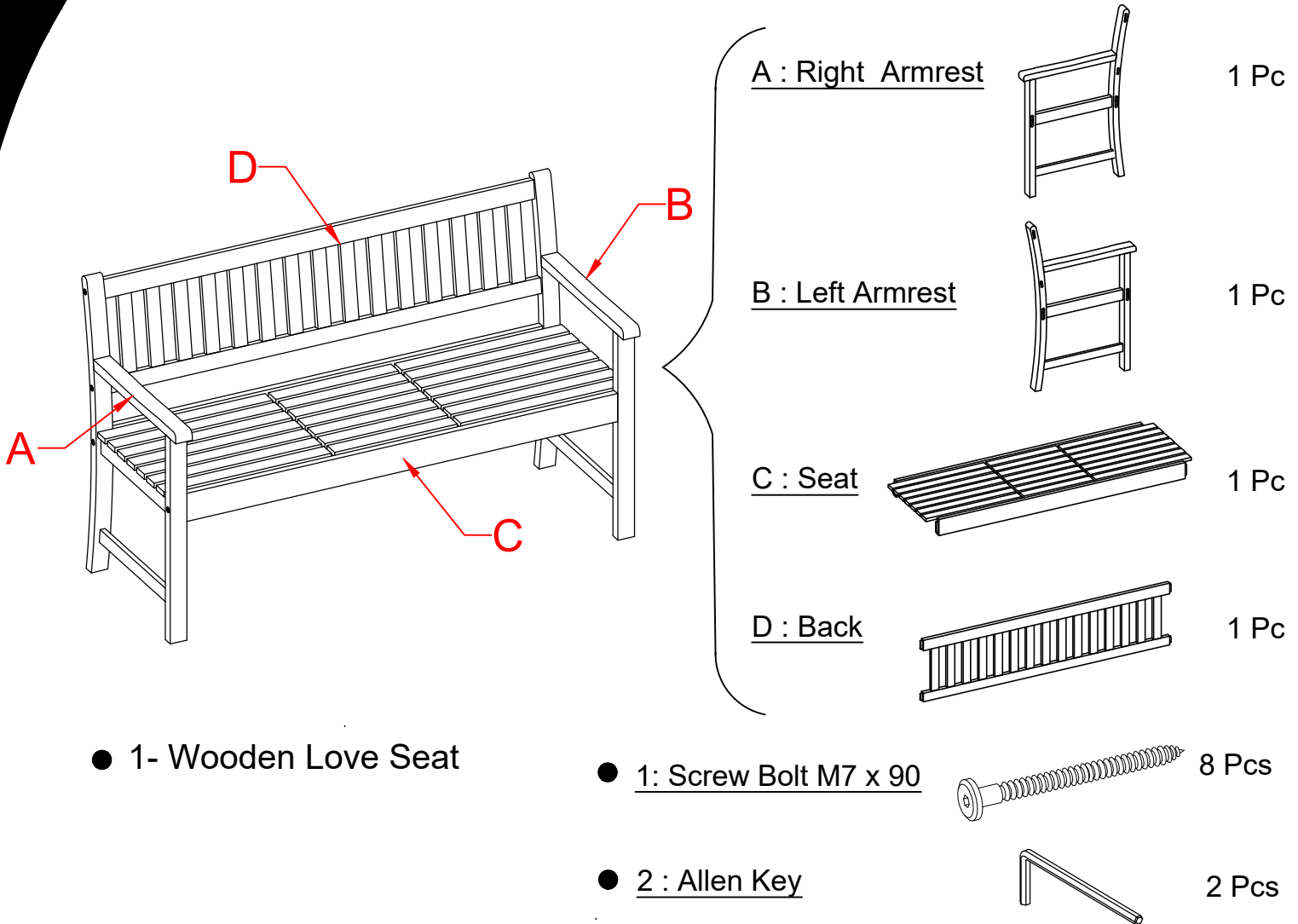

Notice:

1. **50% Tighten before fixing all screws, Allen wrench is recommended instead of an electric drill.**
2. **Place the item on a flat ground to adjust and make sure it remains stable.**
3. **Tighten up all screws with tools gradually.**
4. **If the screws are not aligned with holes during assembly, please loosen all the other screws to 50% and continue the assembly process.**
5. **If the item is not stable, please loosen all the screws, adjust it on a flat ground and tighten up all screws again.**
6. **Note : If one or some screws are fully tightened during assembly, chances are the others will not be aligned with holes. In addition, all the holes are designed to be relatively larger to provide more space for the adjustment of the screws.**



For successful installation, When installing, please do not tighten the screws once, when the screws are all installed, a unified tighten all the screws

Assembly steps

For successful installation, When installing, please do not tighten the screws once, when the screws are all installed, a unified tightten all the screws

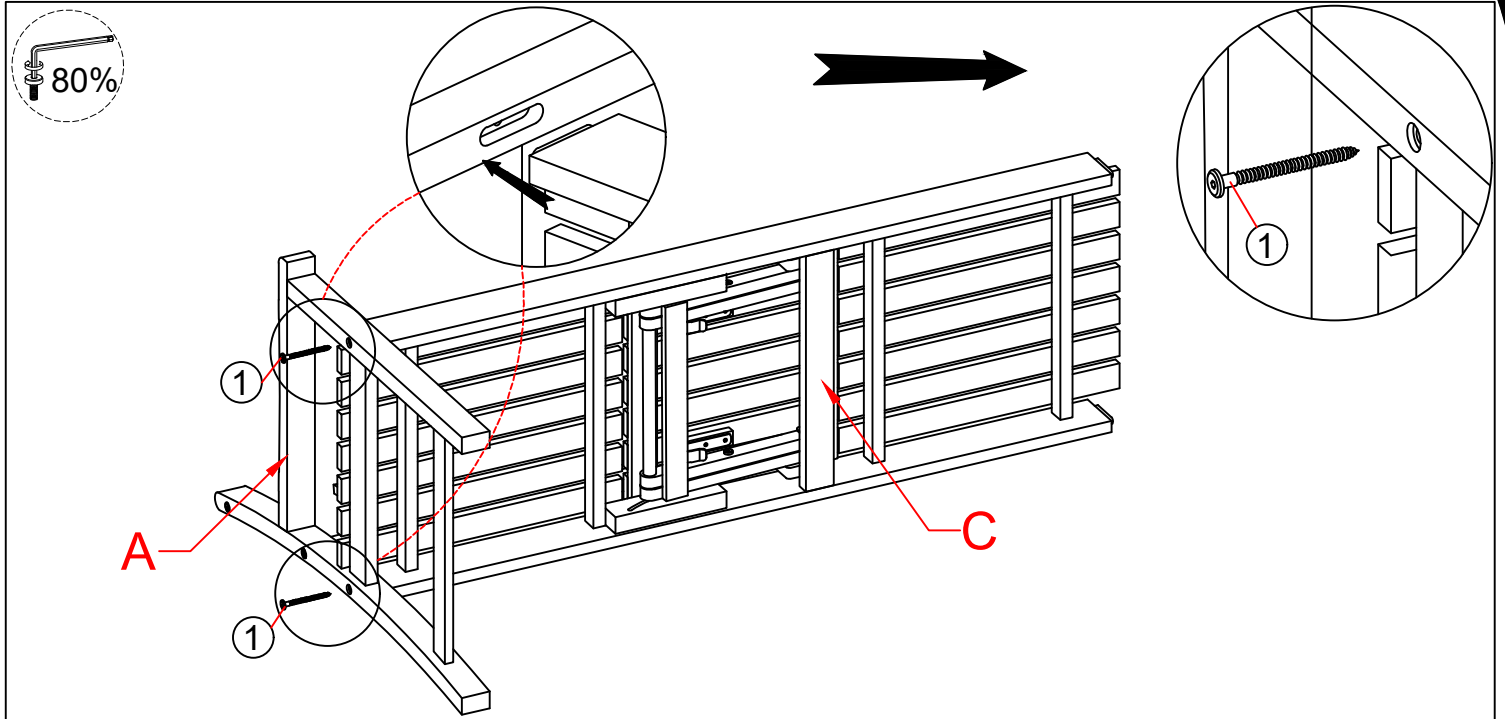

Step 1: Connect Right Armrest (A) & Seat (C), tighten Bolt (1) with Allen Key (2).

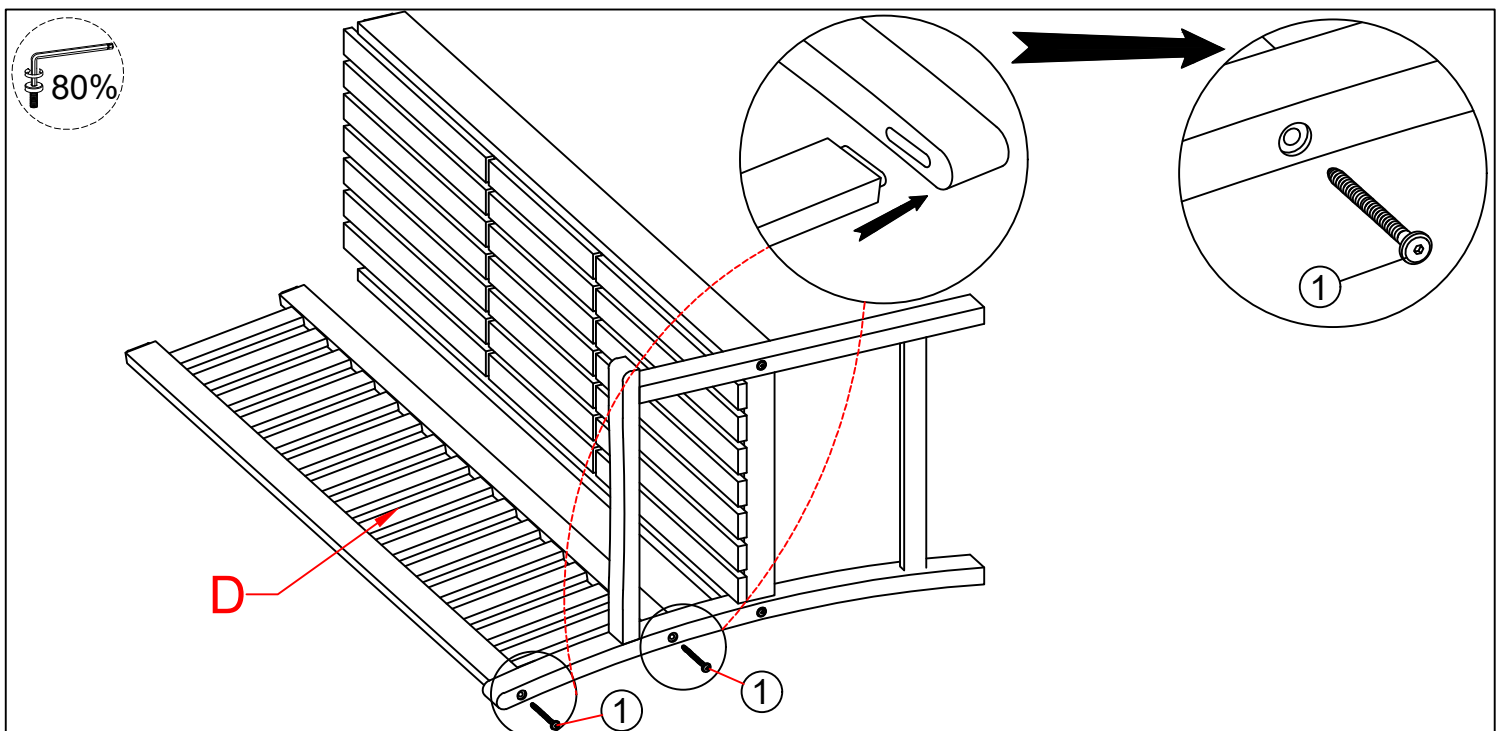

Step 2: Connect The Part from Step 1 & Back (D), tighten Bolt (1) with Allen Key (2).

Assembly steps

Tips : DO NOT tighten any screws until all the parts are put together.

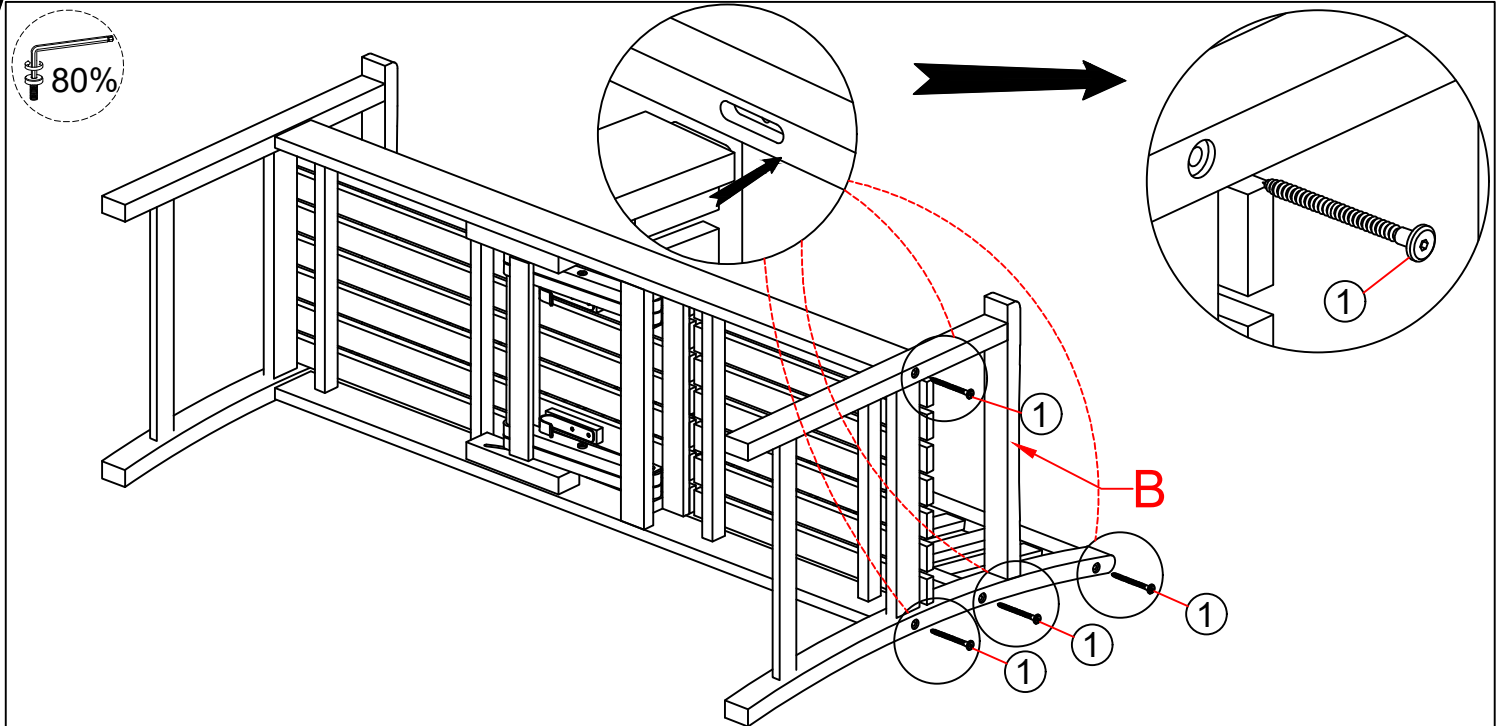

Step 3: Connect The Part from Step 2 & Left Armrest (B), tighten Bolt (1) with Allen Key (2).



STEP4 : Put the Love Seat upright and make sure all legs are level, then firmly tighten Bolts with Allen Key (2) to finish Love Seat .