

Assembly Instructions

Please check the package quantity first.

2-seater sofa contains 1 cartons A.

3-seater sofa contains 1 cartons A and 1 carton B.

4-seater sofa contains 1 cartons A and 2 cartons B.

Carton A

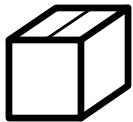

Base 2PCS	Armrest 2PCS	Backrest 2PCS	Cushion 2PCS	Pillow 2PCS	M6 Screw 8PCS	M6 Gasket 8PCS	3CM Leg 8PCS	M5 Screws 8PCS

Carton B

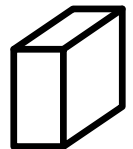

Base 1PC	Backrest 1PC	Cushion 1PC	Pillow 1PC	M6 Screw 2PCS	M6 Gasket 2PCS	3cm Leg 4PCS	M5 Screws 4PCS

Step 1: Flip the sofa base over, unzip it and remove all the parts.

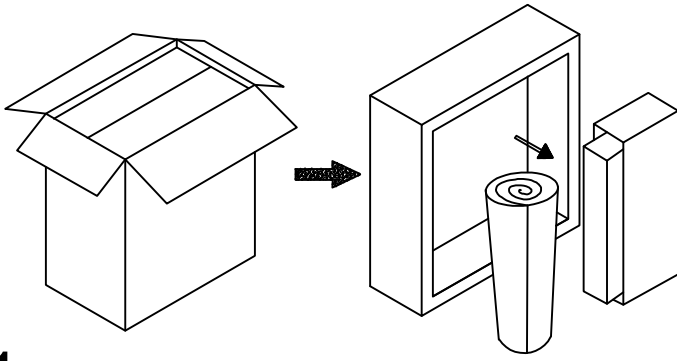

1

Step 2: Install the legs using screws and a screwdriver.

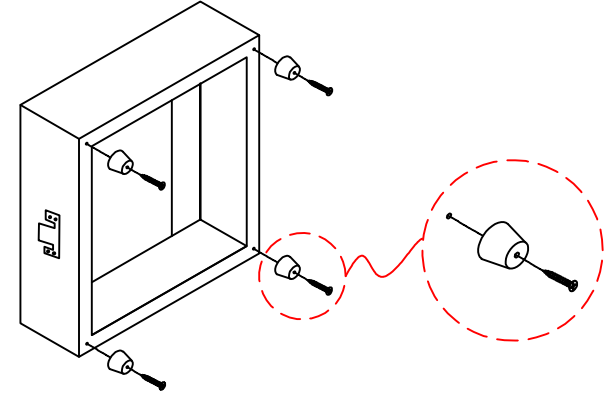

2

Step 3: Use screws and screwdriver to install the armrests and backrest. (the middle position does not require armrests)

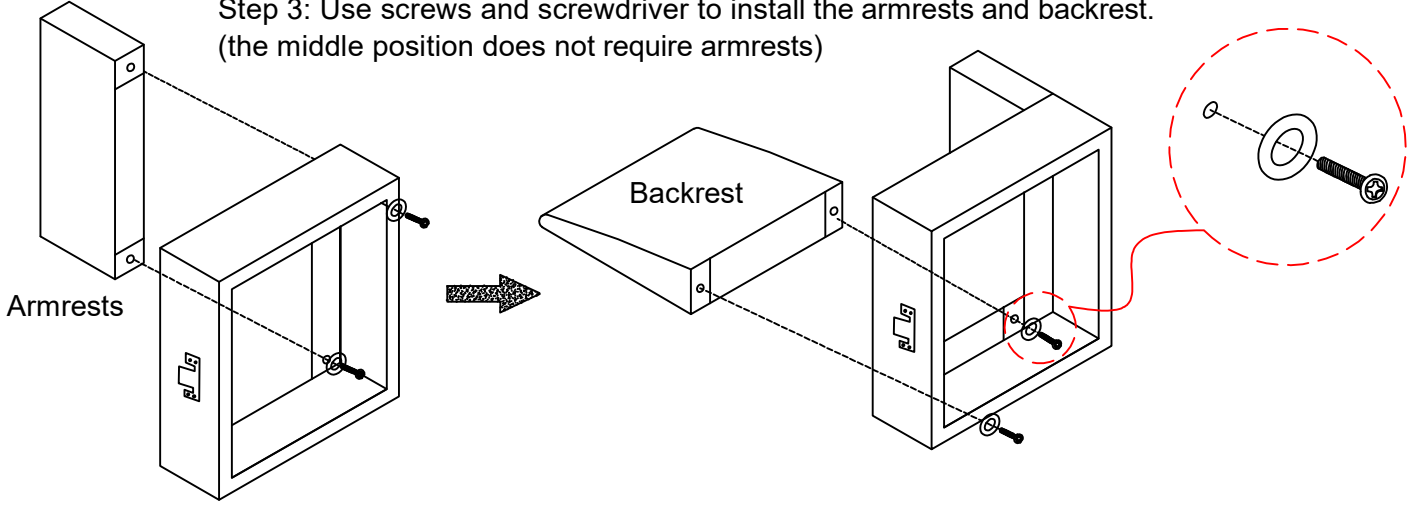

3

Step 5: Unpack the cushions and soft bags to unzip them and place them on the seat.

Note: Due to vacuum packaging and transportation of the soft bag, the sponge filled inside will take 24-48 hours to return to its softest state.

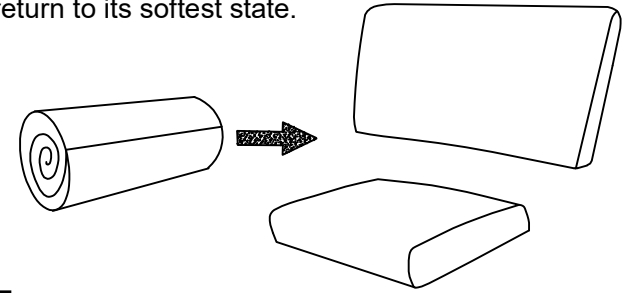

5

Step 4: Fasten the sofa together using the connectors between the seats.

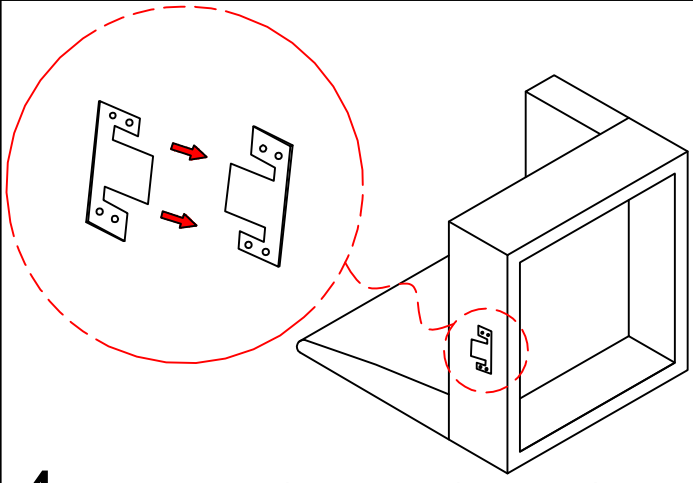

4

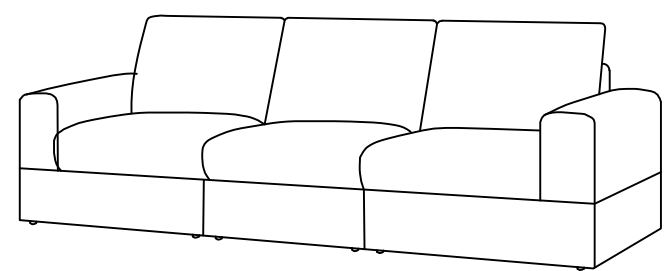
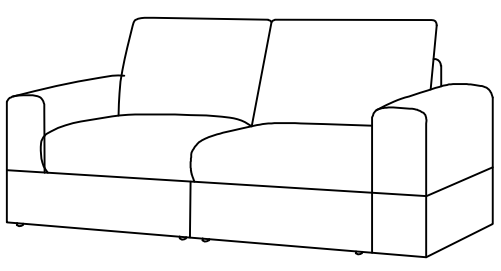

6

FINISH!