

ASSEMBLY INSTRUCTIONS

IMPORTANT SAFETY INFORMATION!

- **We recommend the wearing of non-slip protective gloves throughout the assembly process. We also recommend the wearing of steel capped protective shoes, protective head gear, safety glasses and full length clothing. If step ladders are to be used we recommend one person holds the ladder whilst the other is using them. If necessary a third person should be used. Do not attempt to erect the building in windy conditions. Follow any safety precautions quoted by the manufacturer for any equipment you use.**
- **Every precaution has been taken to ensure that your building has no element incorrectly placed or possibly hazardous. However prior to use please check for raised grain or splinters and sand if necessary. Check that all elements are secure against reasonable force.**

Windows And doors

- **UNDER NO CIRCUMSTANCES MUST THE DOOR**
- **OR WINDOW FRAMES BE NAILED TO THE LOGS**
- **Timber is a live material and the logs expand and contract and must be free moving within the door and window units .**



Tools required

- . Hammer
- . Rubber mallet
- . Spirit level
- . Stepladder
- . Battery-powered drill/screwdriver
- . 8mm drill
- . 3mm drill
- . Tape measure
- . Gloves
- . Sharp knife and saw
- . string

IMPORTANT!

1. **Check all components before commencing with the construction of your**
2. **Keep all timber dry or your building will not fit together.**
3. **We also recommend that you seal the corner log joints with silicone sealant (not supplied).**
4. **We recommend a minimum of two people required for assembly.**
5. **Read through all the instructions before constructing your pine lodge.**
6. **You will see there is a set of lettered drawings showing each side of the building. You will find these letters printed at one end of each log or in the slot.**

PLEASE NOTE

Wood is a natural product and is therefore prone to changes in appearance, including some warping, movement and splitting, particularly during unusual climatic conditions (long hot or wet spells of weather). As a natural occurrence this is not covered by a guarantee.

Preparation of base

Prior to assembly a suitable perfectly flat concrete base must be provided
Actual floor area [see drawings](#).

It should be at least the same size as the main building without the returns that stick out at the corners (180mm less than the external dimensions on stable ground or the same size as the external dimensions including returns on unstable ground- consult a local expert for advice. It should have a very slight fall to prevent water laying on it. We do not recommend slab and / or shingle bases as an uneven base or subsequent settling will cause excessive strain and may damage your building and invalidate your warranty

Treatment/care of your pine lodge

All timber must be dry to apply the timber treatment.

Treat with a suitable decorative wood finish immediately. We recommend that you treat the door and window glazing rebates and beading with a top quality timber treatment before assembly and treat the entire building as soon as assembly is complete, we further recommend that all pieces are treated and again within 3 months of assembly and again at least annually or as frequently as the instructions on the product used recommends.

Note the back of the door and window units unscrew so they can be removed for painting
We would also remind you that you would rarely (if ever) be able to re-treat the underside of the floor boards following assembly.

We strongly recommend that the underside of the floor is treated an absolute minimum of twice.
The floor bearers are pressure treated and don't need to be treated although you may if you wish.
We also recommend that you seal the external corner joints (figE2) with silicone sealant (not supplied)

Parts list

PLEASE LAY OUT PARTS AND CHECK OFF AGAINST THE CHECK LIST

IMPORTANT!

The only parts that require cutting are the angled eaves edgings , final roof and floor boards and the skirting.

DO NOT CUT ANYTHING ELSE

A Windows

1. Decide how you wish to have your windows opening, LH ,RH or top opening.
2. Place one hinge on the inner rebate part of the window; approx. One hinge width along from the rebate edge on the long side. The rounded part of the hinge should sit above the outer edge of the window. Screw the inner piece into position (fig. A1 & A2)using the pre drilled holes in the hinge and 3 x 25mm screws.
3. Repeat with the other hinge. And close the hinges together.

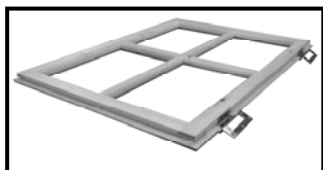

Fig A1 example

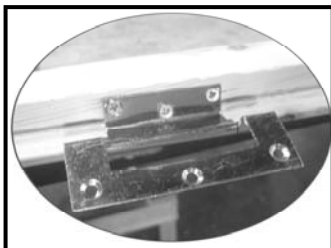

Fig A2

4. Place the window into the aperture. Secure the window to the frame using 3x25mm screws per hinge.
5. **Fitting the draught excluder. This must be done before fitting the casement stays and latches.**



Fig A3

6. Lay the assembled window unit with the opening insert downwards onto your work surface (Fig A3).
7. Position the draught strips so the rubber is against the opening insert and fix with 3x25mm oval nails per strip (Fig A3).
8. At the bottom of each window place a casement stay on top of the draught excluder strip. Visually judge the position of the stay so it looks central. Use a pin to judge how high to position the stay. Fix using 2 x 25mm screws (Fig A4).

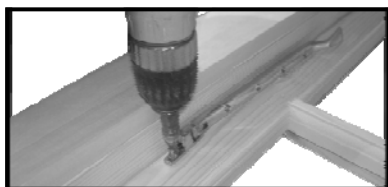

Fig A4

9. Stand the window up so it easier to fix the pins for the casement stays

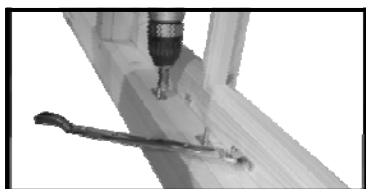

Fig A5

10. Position the first pin so it fits into the first hole on the stay making sure it holds the window tight. Carefully remove the stay holding the pin in position, secure pin using 2 x 25mm screws (Fig A5) . Repeat for other pins.

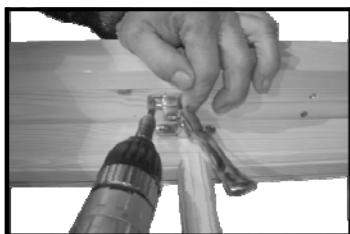

Fig A6

11. Half way up the window insert place the side latch on top of the draught excluder.
12. Use the pin to correctly place the lever and secure using 2x25mm screws for each part (Fig A6).

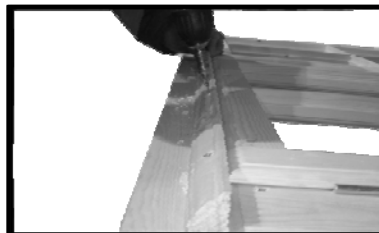

Fig A7

13. Fix the drip bar at the top of the window, there is a thin groove in one of the flat edges this needs to be facing the bottom of the building. Pre-drill seven holes and secure approx. 5mm above window inserts using 7 x 40mm screws.(figA7)

B Double door assembly

1. Refer to letter codes in the table on the front page **AND LARGE DRAWING**.
2. Lay out the parts **DA** and **DB** as in fig B1
3. The 25mm edge to your work surface , Parts **DB** must be inside parts **DA**.
4. Screw together at each corner, 10mm in from the edge (ensuring each corner is flush) with 2x50mm screws (fig B2).

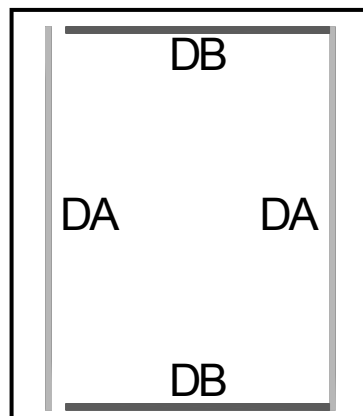

Fig B1

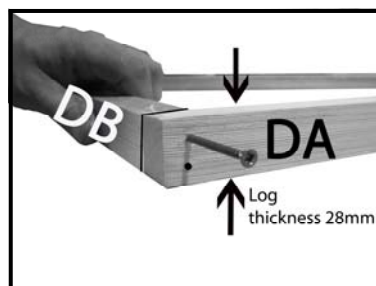

Fig B2

5. **REF.** This frame is set out similar to the pre-constructed window frame.

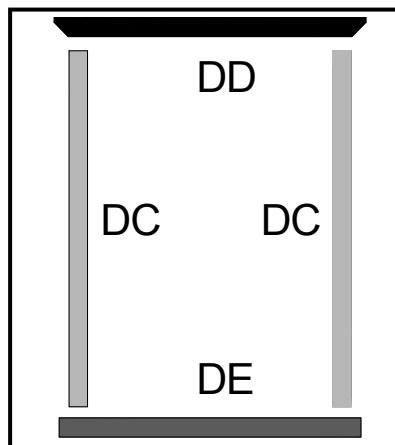

Fig B3

6. Layout parts **DC**, **DD** & **DE** as in fig B3
7. Mark the first hole position 30mm from each end of part **DC** and then the rest at approximately 200mm centres.
8. Note the **DC**, **DD** & **DE** pieces fitted to the opposite side must be drilled offset to this side to ensure the screws miss each other.

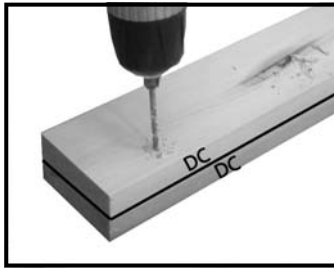

Fig B4

9. Place the other DC part underneath and drill through both pieces with a 3mm drill (fig B4)

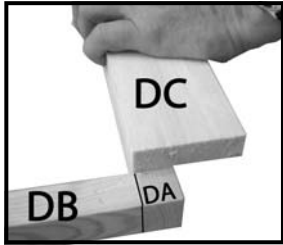

Fig B5

10. Place one of the DC parts on top of the DA parts level with the inside of the frame (fig B5)

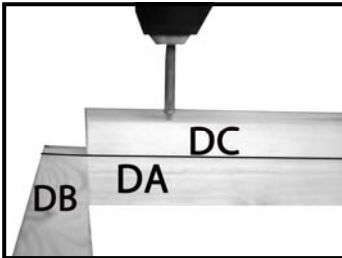

Fig B6

11. Fix to part DC to DA with 40mm screws (fig B6 & B7) important fix at both ends first ensuring that they stay flush then the screws in between again ensuring that parts DA & DC are flush as you go.

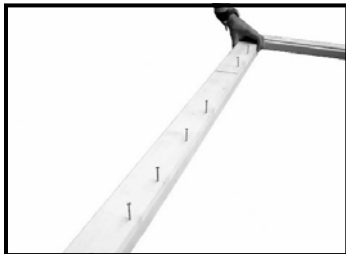

Fig B7

12. Place the DD part on top of a DB part. The DD part is positioned so there is an even overhang (fig B8). Mark out and drill fix as before. But start at 100mm from the end of part DD.

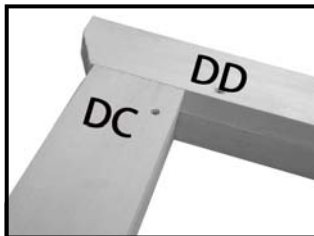

Fig B8

13. Drill (not too deep) and screw in each corner with 40mm screws (fig B9).



Fig B9

14. With a pencil mark the screw centres on the inside long edge of the frame to help ensure the door hinge screws will miss these screws.
 15. Turn frame over and repeat steps 9 to 14 on the other side (fig B10&B11).
 16. **Note** offset drilled holes from first side to ensure they miss each other first hole part DC=40mm part DD 110mm part DC=40mm part DD =110mm

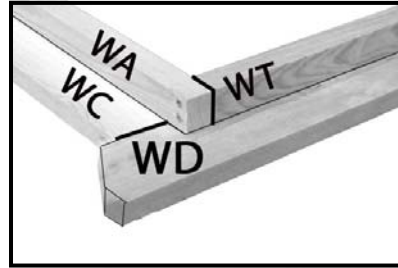

Fig B10

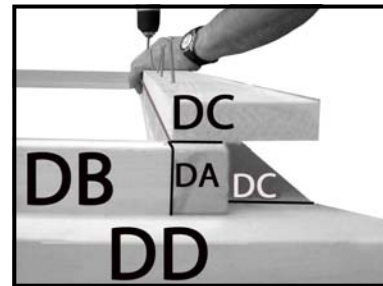

Fig B11

C Doors

1. Lay doors on the floor, as you would view them from the inside of the building. Make sure the door with the lock is situated on the left when viewed from the bottom.
2. Lay the outer frame in position (fig C2).
3. The hinges are fitted on the longest outside edge of the doors.
4. Make a visual judgement to the gap top and bottom of the doors then transfer the screw centre marks (see step B 14) to the doors. This is to ensure the hinge screws miss the frame screws (fig C1)..
5. Lift off the outer frame making note of which way around you have put it.
6. Place the hinges as shown in fig C1 Screw the inner piece of the hinge to the door with 3 x 25mm screws.

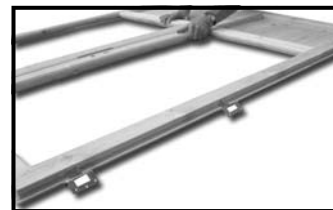

Fig C1

1. Close the hinges and lay the frame assembly over the doors (fig C2).

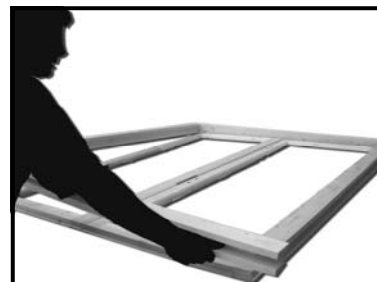

Fig C2

8. Make a visual judgement to set an even gap top/bottom of the doors and secure each hinge with 1x25mm screws (fig C3). Ensure the hinges are tight against the face of the doorframe.



Fig C3

- Stand the assembly up. Note two people needed for this step. Open the doors and secure hinges with remaining 4x25mm screws per hinge.

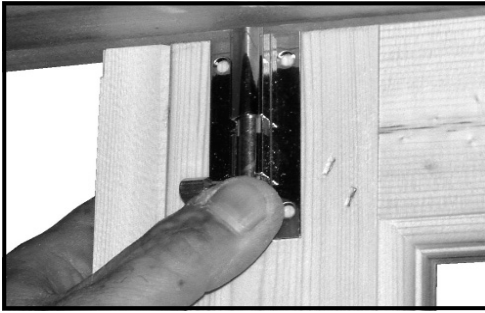

Fig C4

- Fit two bolts on the door without the lock (fig C4). The top bolt should be positioned level with the top of the door. Fix with 4x10mm screws.
- Extend the bolt to meet the frame and mark then drill an 8mm hole (not through the frame) to take the bolt.
- Put the door assembly to one side until required.

D Cabin base frame

See drawing pages

Following the instructions below and with the help of the drawing pages assemble your building up to and including the gables

- On some cabins (see drawings) Both the outer bearers are two bearers that sit side by side, nail these together with 75mm nails at approximately 300mm centres for each pair of bearers (fig D1).



Fig D1

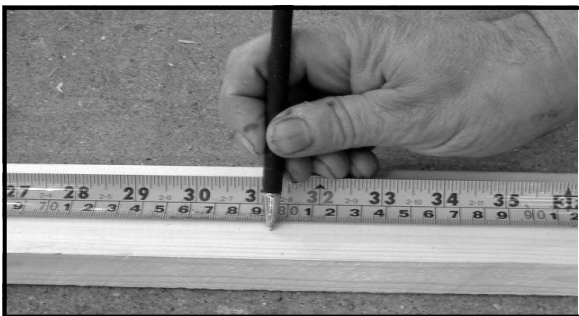

Fig D2

- Take the half height log (normally A1) that the bearers sit on that you see the bearer ends and mark the floor bearer centres, **but not the two pairs of outer bearers**, from one end (fig D2 & drawing pages).

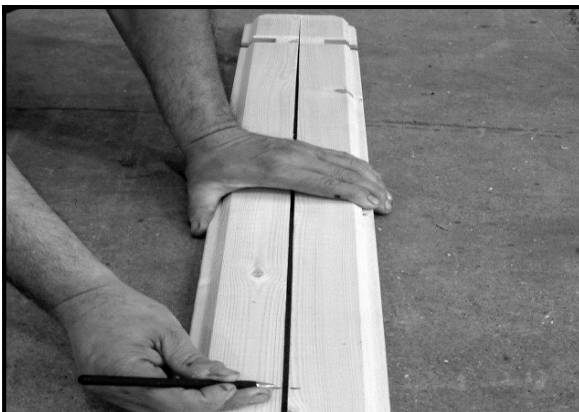

Fig D3

- Place the 'A1' logs against each other and transfer all the lines across (fig D3).
- The bearers stand with the narrowest edge to the floor (fig D4) and their ends 5mm back from the A1 logs face (Level with the chamfer).

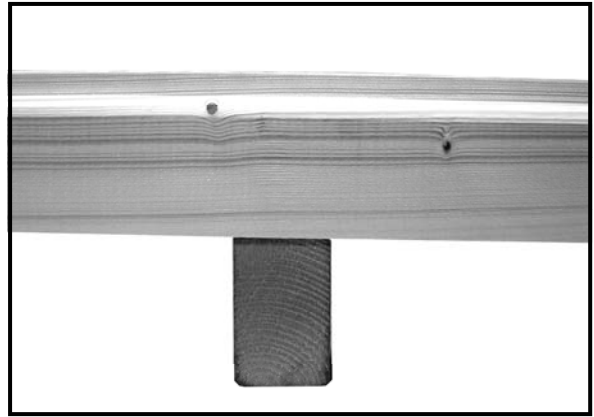

Fig D4

- Assemble the first row of logs on top of the bearers by placing the half height logs in position and then the first of the logs from each wall that run parallel to the bearers on top of them. (See section E4).
- The logs are assembled with the tongues upwards**
- Position the outer bearers so the outer log sits 5mm in from the outer face (fig D5) of the side and front logs.

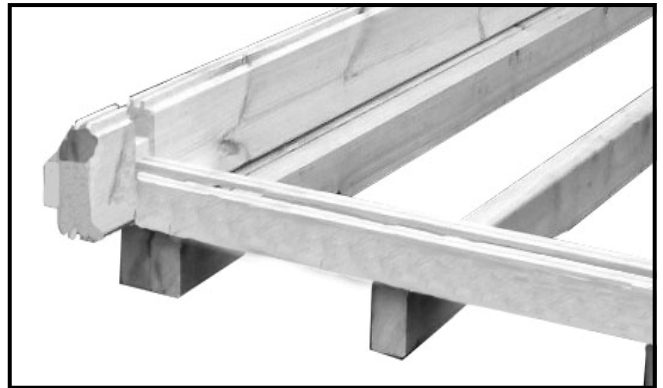

Fig D5

- Cut notches out of the tongues on the A1 logs (fig D6) at centre marks (previous steps) and drill through for fixing to the bearers.
- Important**
- Measure corner to corner, as building must be square
- Also measure length at the centre of the building from wall to wall (A1 to A1) to ensure correct length before fixing to joists with 1x 80mm screw (fig D6) at each bearer.

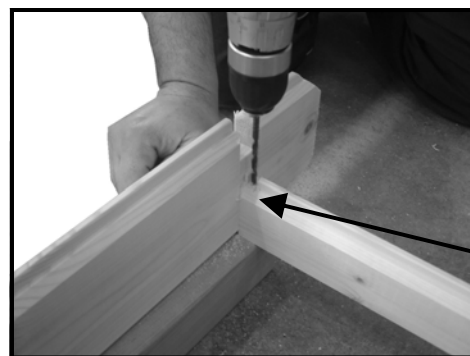
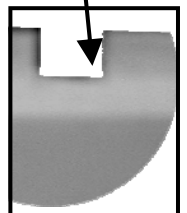

Fig D6



- This is the bottom of all four walls now ready to be built upon.

E Walls

See drawing pages

- Using parts list for each wall layout correct quantity (fig E1) of each component for relevant wall (i.e. front, back) in suitable position for ease of assembly.

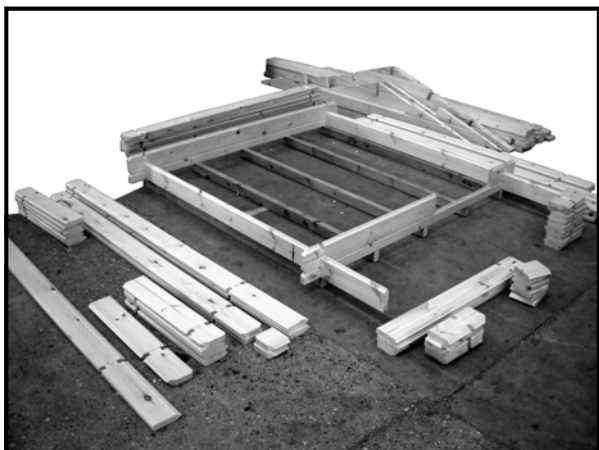

Fig E1-example

- The walls can now be assembled as per drawing pages above. Start building walls by placing all the logs from front to back and then from side to side
- The logs are assembled with the tongues upwards**
- Each log needs to be tapped home to log below using timber block supplied and a rubber mallet (fig E2).

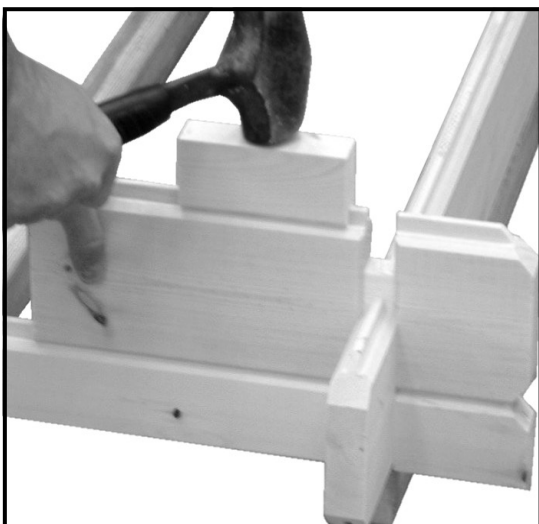

Fig E2

F Inserting windows and doors

AS SOON AS YOU FIT DOOR UNIT FIT HANDLES AND UNLOCK DOOR

- Door unit must be placed into position after the first two layers of full logs have been assembled
- Slide unit into aperture from above (Fig F1 & F2) ensuring unit is completely down and in position.



Fig F1 EXAMPLE



Fig F2

- Window units are fitted as above (fig F2) when you have built up to the correct height



Fig F3 example

- Note** Door and window units do not require fixing to the logs
- Once the door and window units are in place continue assembling the walls as before but slide the logs into the door or window frame (fig F4) from above then tap them down.



Fig F4

- Continue building until you get to the height where the gable starts.

G Gables

See drawing pages

- Assemble the gables as with the walls, the gables must be assembled with the walls as before.
- Once gables are in place knock down all the walls again as in fig E2 to ensure all the walls and gables are fully home
- Fix the gable with 1x80mm screw at each end (fig G1 and as shown on the drawing pages (Some screws may go into roof joists)

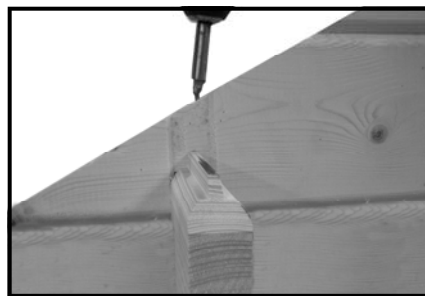

Fig G1

H Roof joists & Roof Edgings

1. Fit roof bearers into slots provided in the gable sections (fig H1 & H2).

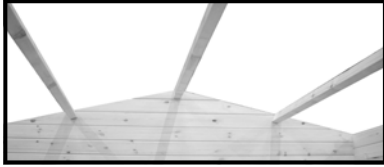

Fig H1

2. Measure the distance between each roof bearer and the roof bearers and walls to ensure all components are fully home before continuing.

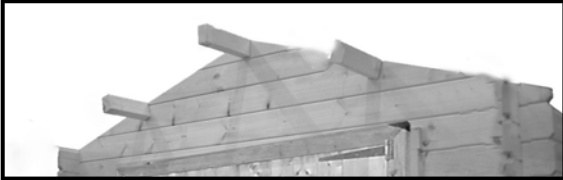

Fig H2 example

3. The roof edgings have a groove to align them on the gables. Using a roof board to align the roof edging with the slope of the gable Fix the roof edgings to the end of the gables with 2 x 80mm screws at each gable (Fig H3).

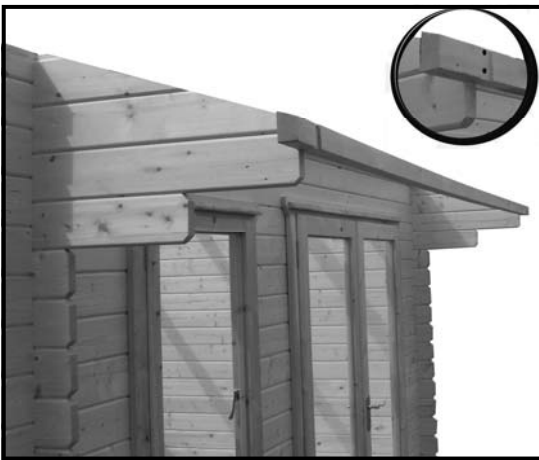

Fig H3

4. Repeat step 3 at the back of the building.

I Eaves edging & Roof boards

1. There are eaves edging strips for the building (2 places) (These may need cutting to fit).
2. Position the eaves edging strips (fig I1 & I2) level at both ends with the gable angle (front and back walls) and screw to the wall with 50mm screws at approximately 400 centres.

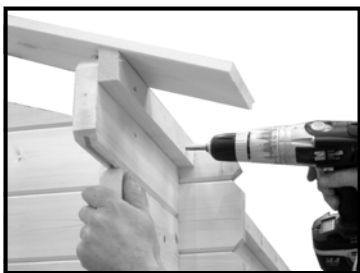

Fig I1



Fig I2

3. The first roof board is now ready to be positioned (fig I3).
Bevel edge downwards
4. **NOTE** only the final boards need trimming on the width .



Fig I3

5. Start at the front, place the board level with the end of the roof bearers and central over the middle bearer to produce an even overhang (fig I3)The roof board should also be level with the end of the roof edging ,if not trim the excess off (should only be a couple of mm).
6. Fix into place at the roof bearers and angled eaves edgings using two 40mm ROUND HEAD nails at each bearer & eaves edging.
7. Next fix roof boards to the roof edgings with 50 mm screws at approximately 300mm centres



Fig I4

8. The final roof board will need to be cut. Place it in position and measure the distance between the end of the roof bearers and the edge of the board. This will tell you how much you need to cut off (fig I4).
9. Fit the 19x70mm eaves edgings onto the roof edgings (**Tiles only**). Place a floor board on top of and over the edge of the roof and place the top of the roof edging level with this (fig I5) and fix with 40mm screws at 400mm spacing's.

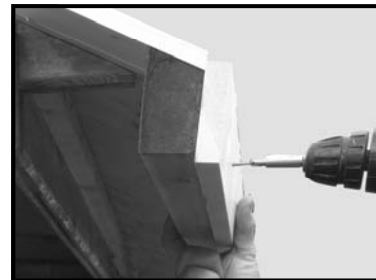

Fig I5

J- FELT ROOF

1. Several rolls of felt has been supplied.



FIG 14

2. Measure the length of the roof (fig 14) and add 200 mm to that length . This length is used to cut all the strips from the rolls of felt. (fig 15)

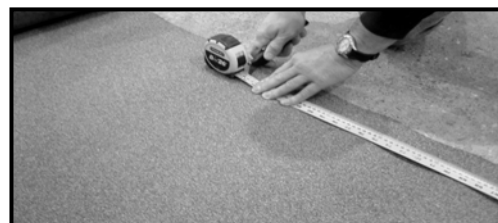

FIG 15

3. Use a piece of floorboard as a guide to cut the felt. (fig 16)
4. Measure up 952mm and mark at the front and back of each side of (and along) the roof.
5. Starting at the lower edge (eaves) on the building side place 1 piece of the felt from front to back of the building .

28 mm BIG Double door assembly supplement

Parts list

Qty.	Description	Length	Code
2	Door frame 25x(log size) 28	1855	DA
2	Door frame 25x (log size) 28	1421	DB
4	Door architrave 70x20mm	1805	DC
2	Door architrave 90x20mm	1581	DD
2	Door architrave 70x20mm	1805	DE -external
2	Door architrave 70x20mm	1561	DF -internal
10	50mm screws		
50	40mm screws		
45	25mm screws		

Door frame

- 1 Refer to letter codes in above table.
- 2 Lay out the parts DA and DB as in fig 1. The 25mm edge to the work surface. Parts DB must be inside parts DA.
- 3 Screw together at each corner, 10mm in from the edge (ensuring each corner is flush) with 2x50mm screws (fig 2).

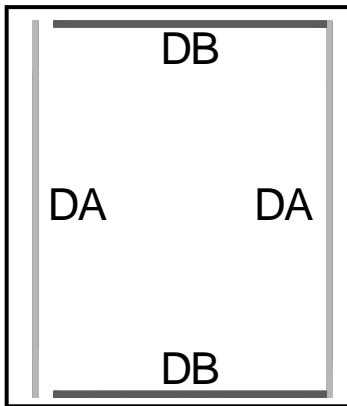

Fig 1

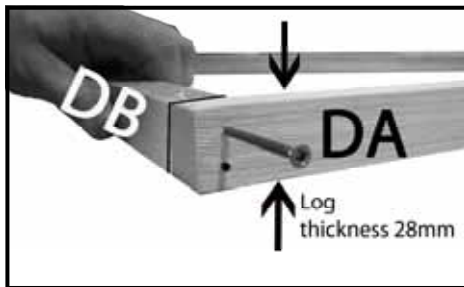

Fig 2

- 4 **REF.** This frame is set out the same as on the pre-constructed window frame.

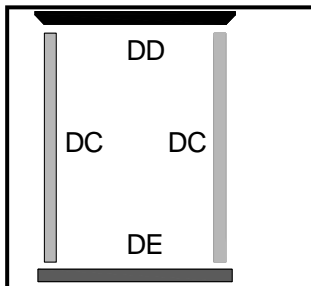

Fig 3

- 5 Layout parts DC, DD & DE (or DF internal door) as in fig 3.
- 6 Mark the first hole position 30mm from each end of part DC and then the rest at approximately 200mm centres.
- 7 **Note** the DC, DD & DE pieces fitted to the opposite side must be drilled offset to this side to ensure the screws miss each other.

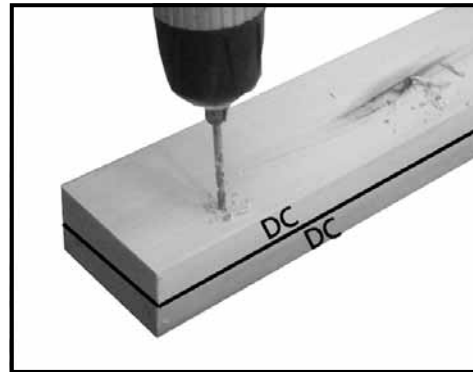

Fig 4

- 8 Place the other DC part underneath and drill through both pieces with a 3mm drill (fig 4)



Fig 5

- 9 Place one of the DC parts on top of the A parts level with the inside of the frame (fig 5).

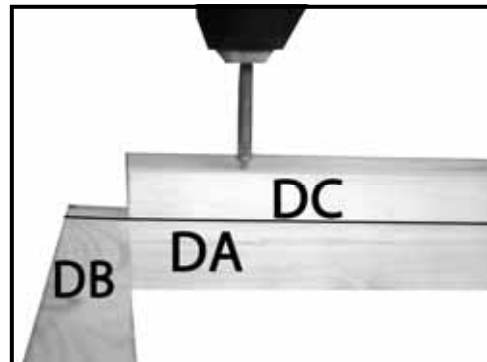

Fig 6

- 10 Fix to part DC to A with 40mm screws (fig 6 & 7) **important** fix at both ends first ensuring that they stay flush then the screws in between again ensuring that parts DA & DC are flush as you go.



Fig 7

- 11 Place a DD part on top of a DB part. the DD part is positioned so there is an even overhang (fig8). Mark out and drill fix as steps 8 to 10. **But** start at 100mm from the end of part DD.
- INTERNAL DOORS** have the DF pieces instead of the DE parts and finish flush with the bottom of the DB part underneath and square to the DC parts.
- THE FLOORBOARDS GO UNDER THE DOOR FRAME.**

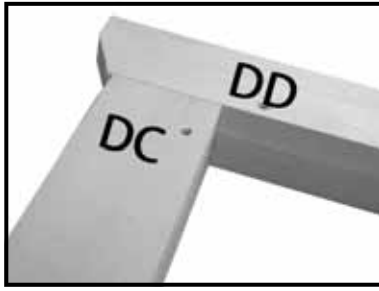

Fig 8

12 Drill (not too deep) and screw in each corner with 40mm screws (fig 9).



Fig 9

- 13 With a pencil mark the screw centres on the inside long edge of the frame to help ensure the door hinge screws will miss these screws.
 14 Turn frame over and repeat steps 5 to 13 on the other side (fig 10&11).
 15 Note offset drilled holes from first side to ensure they miss each other first hole part DC=40mm part DD =110mm

Doors-MAY DE SOLID DOORS

Bradenham has piano hinges and black door knobs fit doors after frame in building

- 1 Lay doors on the floor, as you would view them from the inside of the building. Make sure the door with the lock is situated on the left when viewed from the bottom.
- 2 Lay the outer frame in position (fig 14).
- 3 The hinges are fitted on the longest outside edge of the doors.
- 4 Make a visual judgement to the gap top and bottom of the doors then transfer the screw centre marks (step A 13) to the doors. This is to ensure the hinge screws miss the frame screws.
- 5 Lift off the outer frame making note of which way around you have put it.
- 6 Place the hinges as shown in fig 12 & 13. Screw the inner piece of the hinge to the door with 2 x 25mm screws.

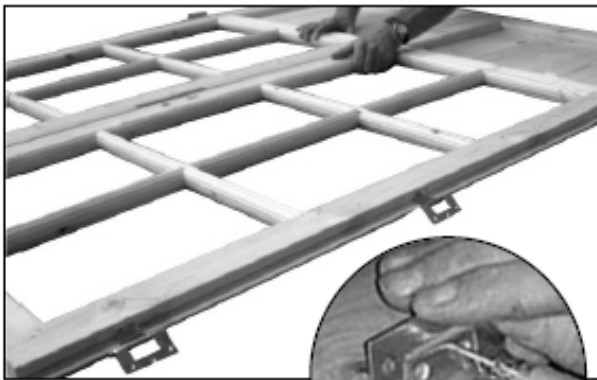

Fig 12

Fig 13

7 Close the hinges and lay the frame assembly over the doors (fig 14).

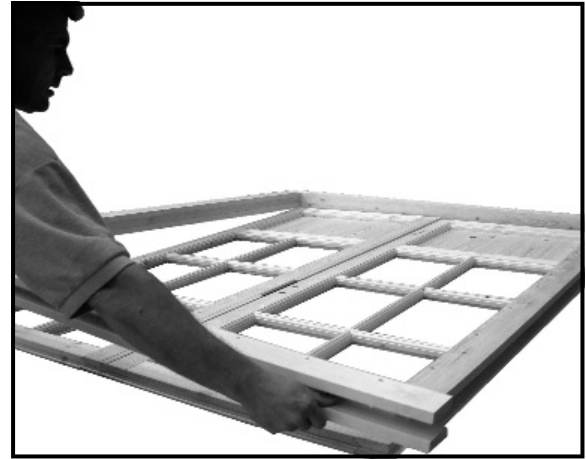

Fig 14

8 Make a visual judgement to set an even gap top/bottom of the doors and secure each hinge with 1x25mm screws (fig 15). **Ensure the hinges are tight against the face of the doorframe.**

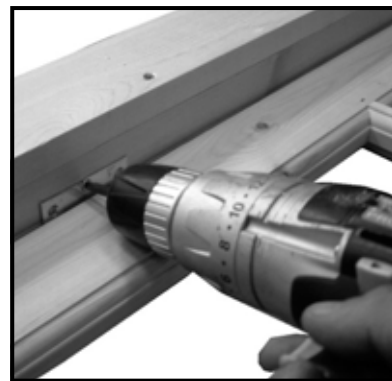

Fig 15

- 9 Stand the assembly up. **Note two people needed for this step.** Open the doors and secure hinges with remaining 4x25mm screws per hinge.
- 10 Lay the assembly down again with the doors facing down and Position the draught strips so the rubber is against the opening door and fix with 9x32mm oval nails for either side and 9x25mm oval nails each top and bottom (fig 16).
- 11 **Take note of where you are going to put the door bolts so there are no nails where you need to drill (step 12).**



Fig 16

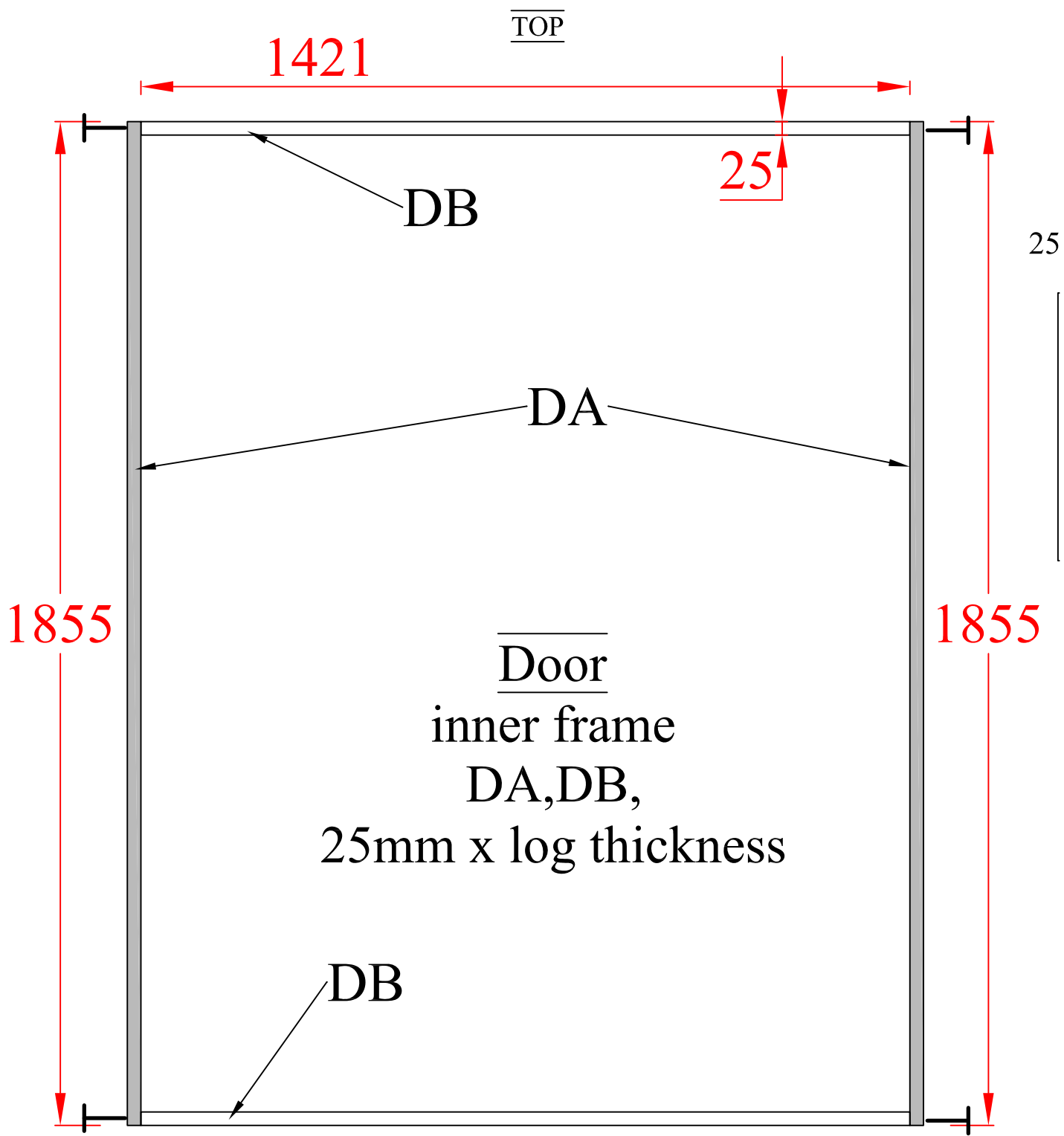

Fig 17

- 12 Fit two bolts on the door without the lock (fig 17). The top bolt should be positioned just below the draught strip at the top of the door. Fix with 4x10mm screws.
- 13 Extend the bolt to meet the draught strip and mark then drill an 10mm hole through the draught strip (**not all the way through the frame**) to take the bolt.
- 14 Put the door assembly to one side until required.

34/44/70 DOUBLE DOOR
-INNER FRAME ASSEMBLY

DOUBLE GLAZING
beading must be sealed
with low modulus
silicone sealant



rubber
drip bar

DOUBLE GLAZING
beading must be sealed
with low modulus
silicone sealant

28/34/44/70DOUBLE DOOR OUTER
FRAME ASSEMBLY

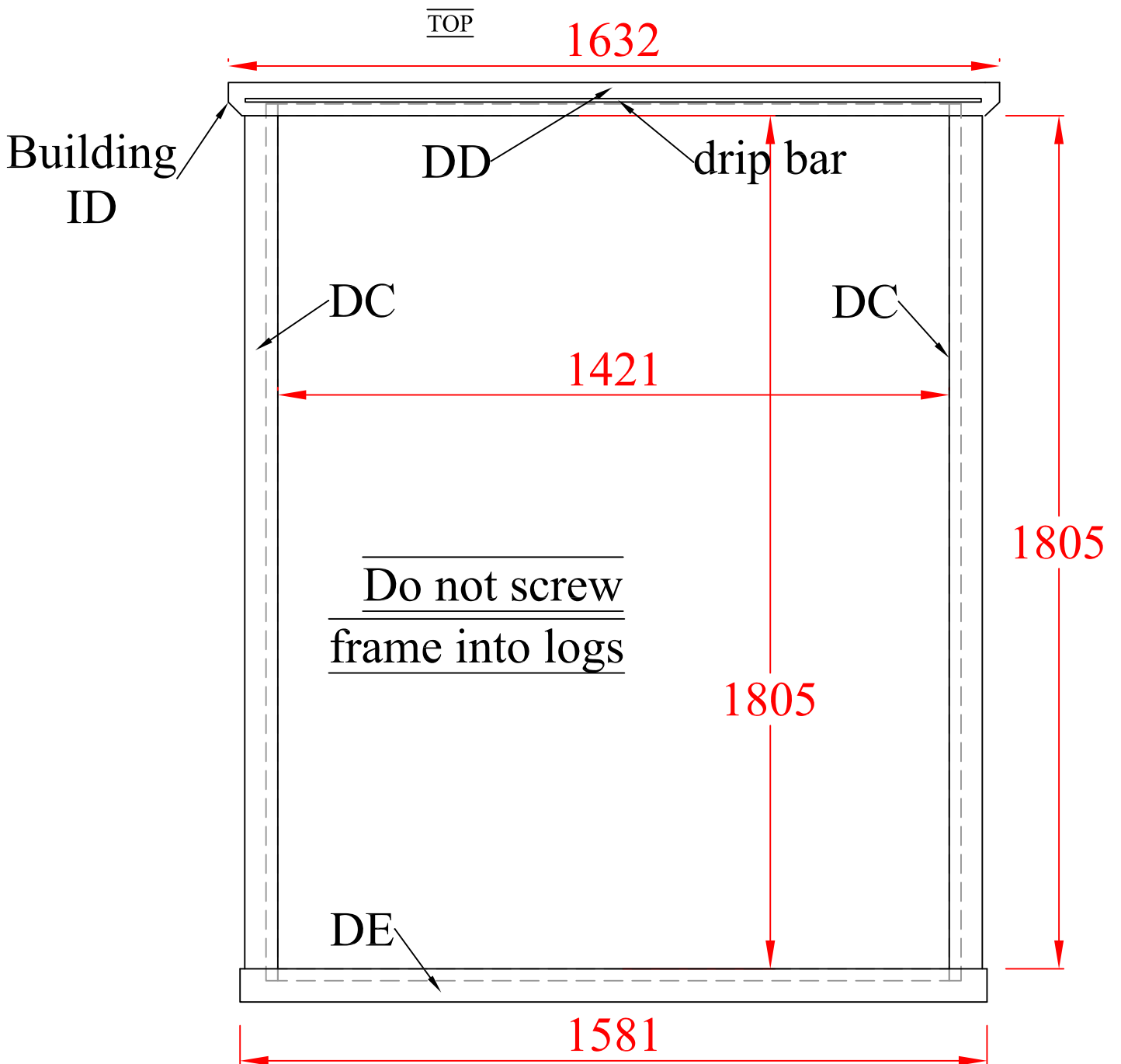

CABIN-Single Window assembly supplement

Parts list

QTY	DESCRIPTION	LENGTH W4	LENGTH W6	LENGTH W8	LENGTH Solway 28	CODE
2	WINDOWS	-W4	-W6	mm	Solway	
2	25mm x log thickness framing	mm	1196mm	mm	mm	WA
1	25mm x log thickness framing	mm	683mm	mm	mm	WB
1	25mm x log thickness framing	mm	633mm	mm	mm	WT
4	70X20 FRAMING	mm	1276mm	mm	mm	WC
2	90X20 FRAMING	mm	842mm	mm	mm	WD
2	70X20 FRAMING		633mm	mm	mm	WE
2	Draught excluder	mm	633mm	mm	mm	
2	Draught excluder	mm	1143mm	mm	mm	
1	DRIP BAR	800mm	800mm	0mm	mm	D
	DESCRIPTION	QTY	QTY	QTY		CODE
	CASEMENT STAY	1	1	2	2	
LENGTH	SIDE LATCH	1	1	0	0	
	Hinges	2	2	2	2	
50mm	SCREWS		12			
40mm	SCREWS		54			
25mm	SCREWS		26			
25mm	Oval nails		22			

Windows– Inc frame assembly

1. **Refer to the two window drawing pages** and to letter codes in contents table above . The **WT** (inner) and **WD** (outer) parts will be at the top of the window frame.
2. To be sure you can lay all the pieces, including inserts together without fixing to familiarise yourself with the assembly.
3. Make sure the window insert fits inside the frame with a 5mm gap all around.
4. Lay out the parts **WA** and **WB** and **WT** as in the inner frame assembly drawing. The narrowest (25mm) edge to the work bench and the side the size is the same as the log thickness as shown in fig A1 . Part **WT** must be inside parts **WA** and part **WB** underneath the two **WA** parts (Fig A1) .
5. Pre drill 2 3mm holes at one end of the **WA** only and at both ends of the **WB** parts (**see drawing**)and screw together at each corner,10mm in from the edge (ensuring each corner is flush) with 2x50mm screw (fig A1).

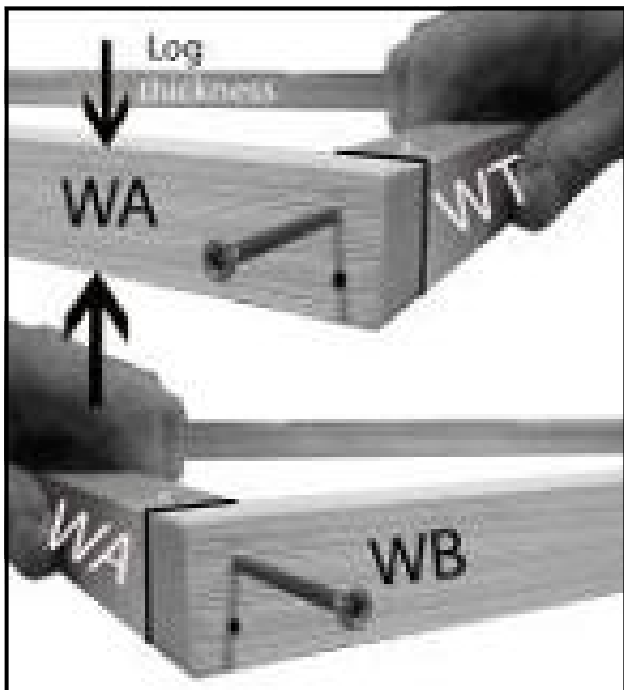

Fig A1

7. Layout parts **WC** ,**WD** , **WE** & **WJ** on top of the previous assembly as shown in the outer frame drawing.



Fig A2

8. Mark the first hole position 30mm from the end of part **WC** that is adjacent to the **WD** part , at the other end central to the **WB** part and then the between at approximately 300mm centres .
9. Note the **WC** , **WD** & **WE** pieces fitted to the opposite side must be drilled offset to this side to ensure the screws miss each other.
10. Place the other **WC** part underneath and drill through both pieces with a 3mm drill (fig A2).

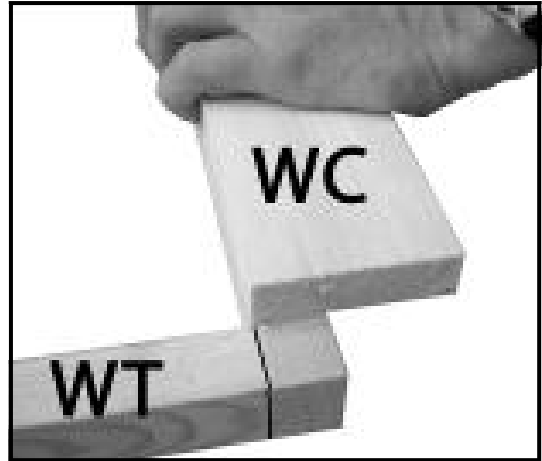

Fig A3

11. Place one of the **WC** parts on top of the **WA** part level with the inside of the frame and the bottom of the **WT** part (fig A3).
12. Fix to part **WC** to **WA** with 40mm screws ,spaced as before. (fig A4 & A5)
13. **important** fix at both ends first ensuring that they stay flush then the screws in between again ensuring that parts **WA** & **WC** are flush as you go.

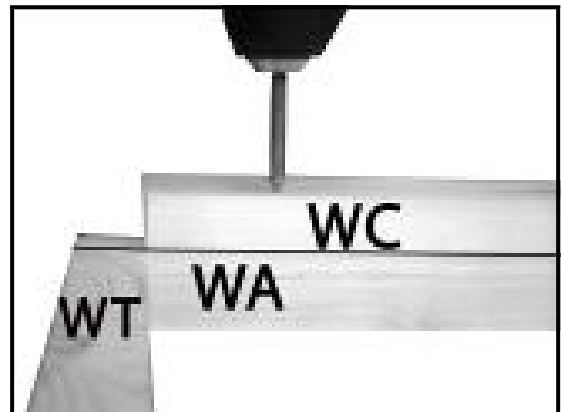

Fig A4

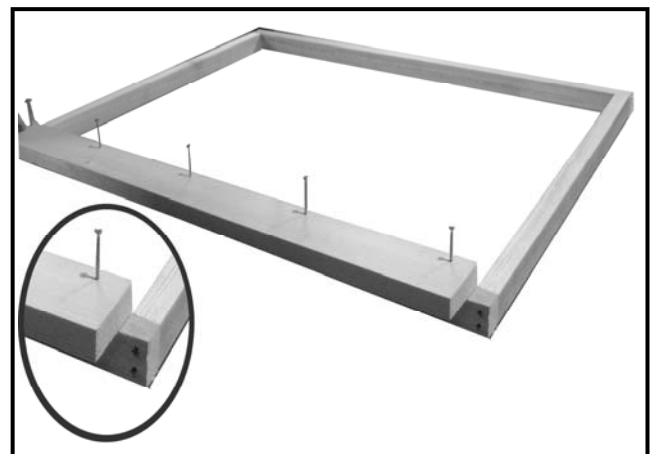

Fig A5

14. Place a **WD** part on top of a **WB** part. The **WD** part is positioned so there is an even overhang (fig A6). Mark out and drill fix as before. But start at 100mm from the end of part **WD**.



Fig A6

15. Drill (not too deep) and screw in each corner with 40mm screws (fig A7).



Fig A7

16. With a pencil mark the screw centres on the inside long edge of the frame to help ensure the hinge screws will miss these screws.

17. Turn frame over and repeat on the other side fig A8 & A9).

18. **Note offset drilled holes from first side to ensure they miss each other first hole part WC =30mm part WD =100mm. LEAVE THE INNER SCREWS LOOSE SO YOU CAN REMOVE FRAME FROM THE BUILDING FOR PAINTING.**

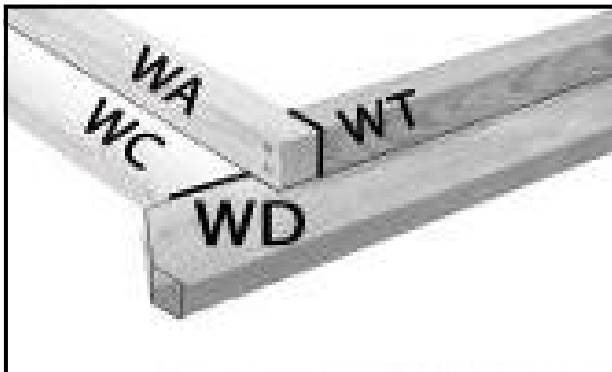

Fig A8

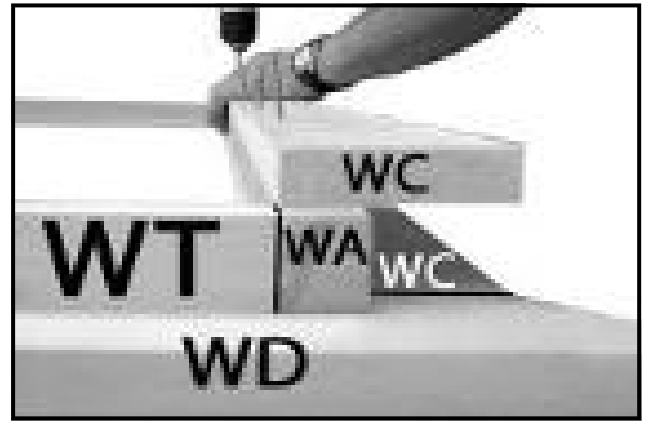

Fig A9.

19. **Window insert.** Place one hinge on the inner rebate part of the window; approx. One hinge width along from the rebate edge of the longest edge of the insert. The rounded part of the hinge should sit above the outer edge of the window. Screw the inner piece into position (fig. A10 & A11) using the pre drilled holes in the hinge and 3 x 25mm screws. Repeat with the other hinge. And close the hinges together.

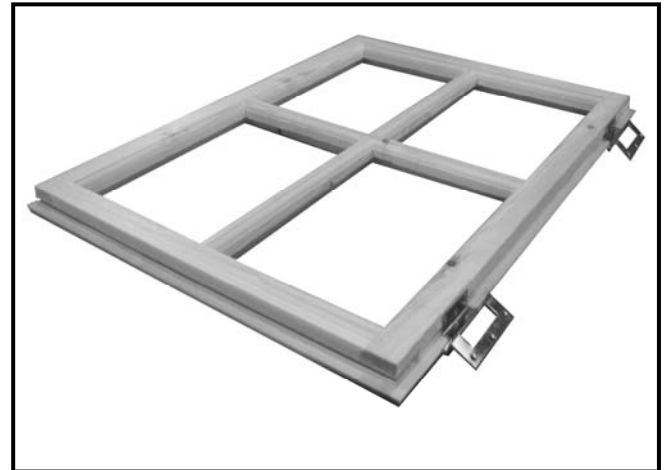

Fig A10– STYLE MAY VARY

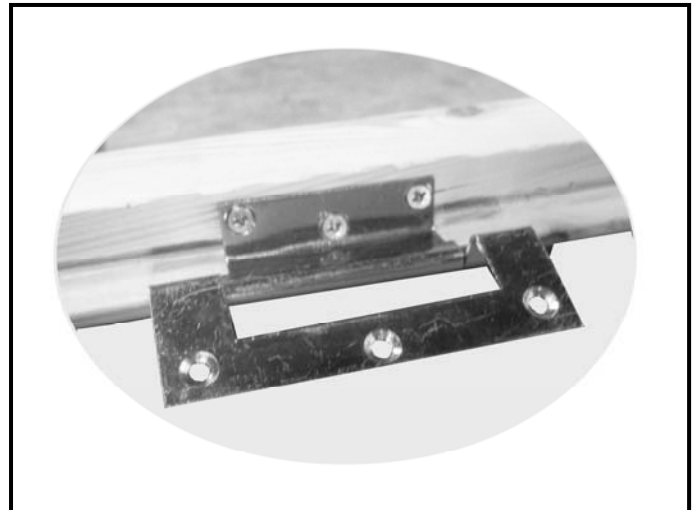

Fig A11

20. Place the window into the aperture (fig A12) **ensure that part WC** is against the hinges .

21. Secure the window to the frame using 3x 25mm screws per hinge, (fig. A13) again through the predrilled holes in the hinge.

22. Repeat.

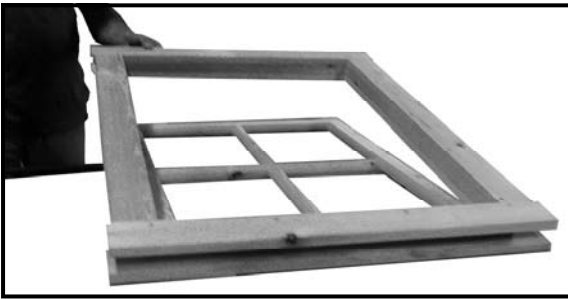

Fig A12 example

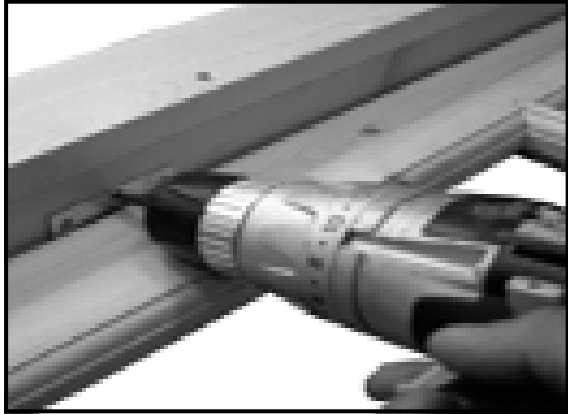

Fig A13

23. Open the window fully in order to fit a further 2x 25mm screws per hinge (Fig. A14).

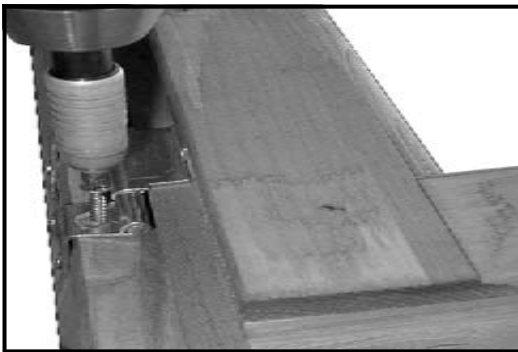

Fig A14

24. **Fitting the draught excluder. This must be done before fitting the casement stays and latches.**

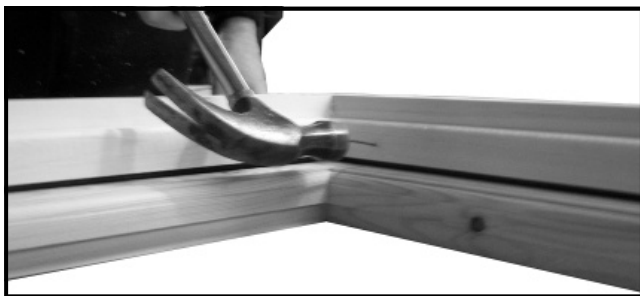

Fig A15

25. Lay the assembled window unit with the opening insert downwards onto your work surface (Fig A15).

26. Position the draught strips so the rubber is against the opening insert and fix with 25mm oval nails, 1 at either end and approx 300mm centres per strip (Fig A15).

27. At the bottom of each window place a casement stay on top of the draught excluder strip. Visually judge the position of the stay so it looks central. Use a pin to judge how high to position the stay. Fix using 2 x 25mm screws (Fig A16).

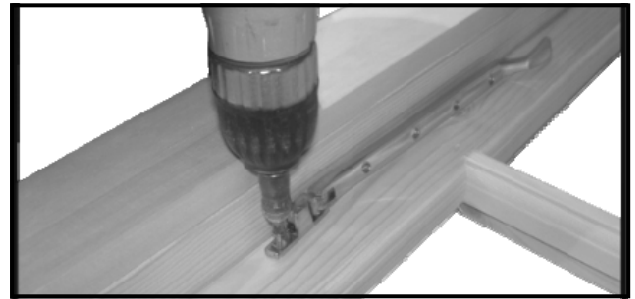

Fig A16

28. Stand the window up so it easier to fix the pins for the casement stays

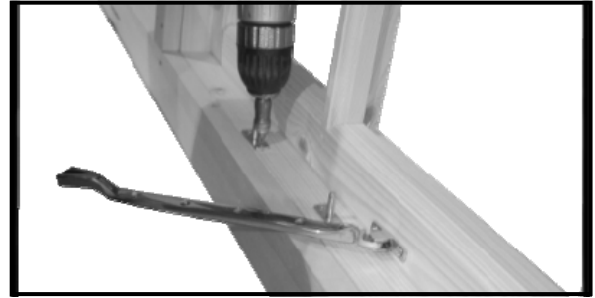

Fig A17

29. Position the first pin so it fits into the first hole on the stay making sure it holds the window tight. Carefully remove the stay holding the pin in position, secure pin using 2 x 25mm screws (Fig A17) . Repeat for other pins.

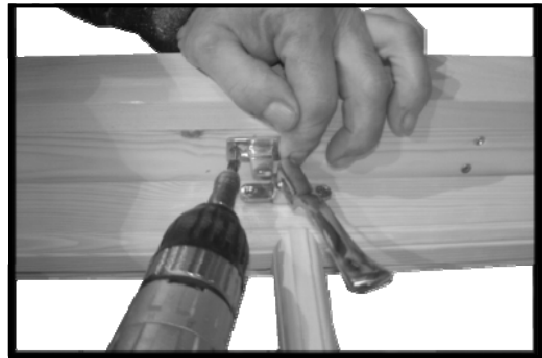

Fig A18

30. Along side one of the horizontal bars ion the window insert place the side latch on top of the draught excluder (Fig A18).

NOTE The top hung windows do not require a latch.

31. Use the pin to correctly place the lever and secure using 2x25mm screws for each part (Fig A18).

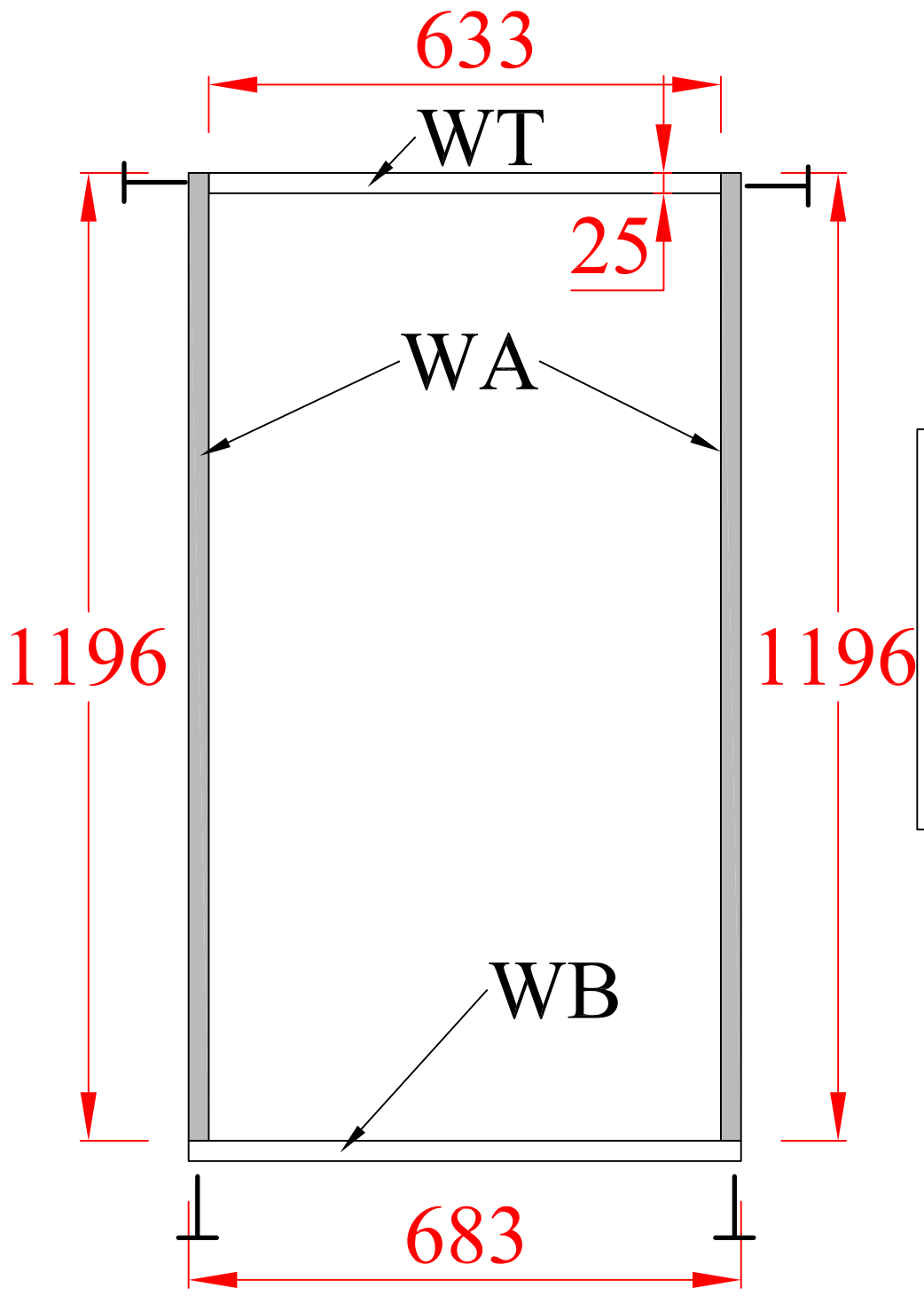

Fig A19

32. Fix the drip bar at the top of the window, there is a thin groove in one of the flat edges this needs to be facing the bottom of the building. Pre-drill holes and secure approx. 5mm above window inserts using 1 x 40mm screws. (figA19) , 50mm in at each end and approx 300mm centres

WINDOW
-INNER FRAME
ASSEMBLY

TOP



Window
inner frame
WA, WB, WT
25mm x log size

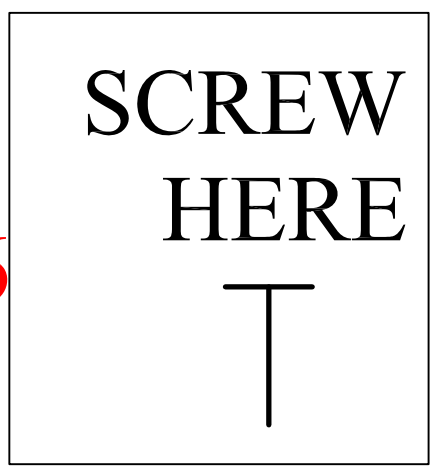

rubber
drip bar

WINDOW-
OUTER FRAME
ASSEMBLY

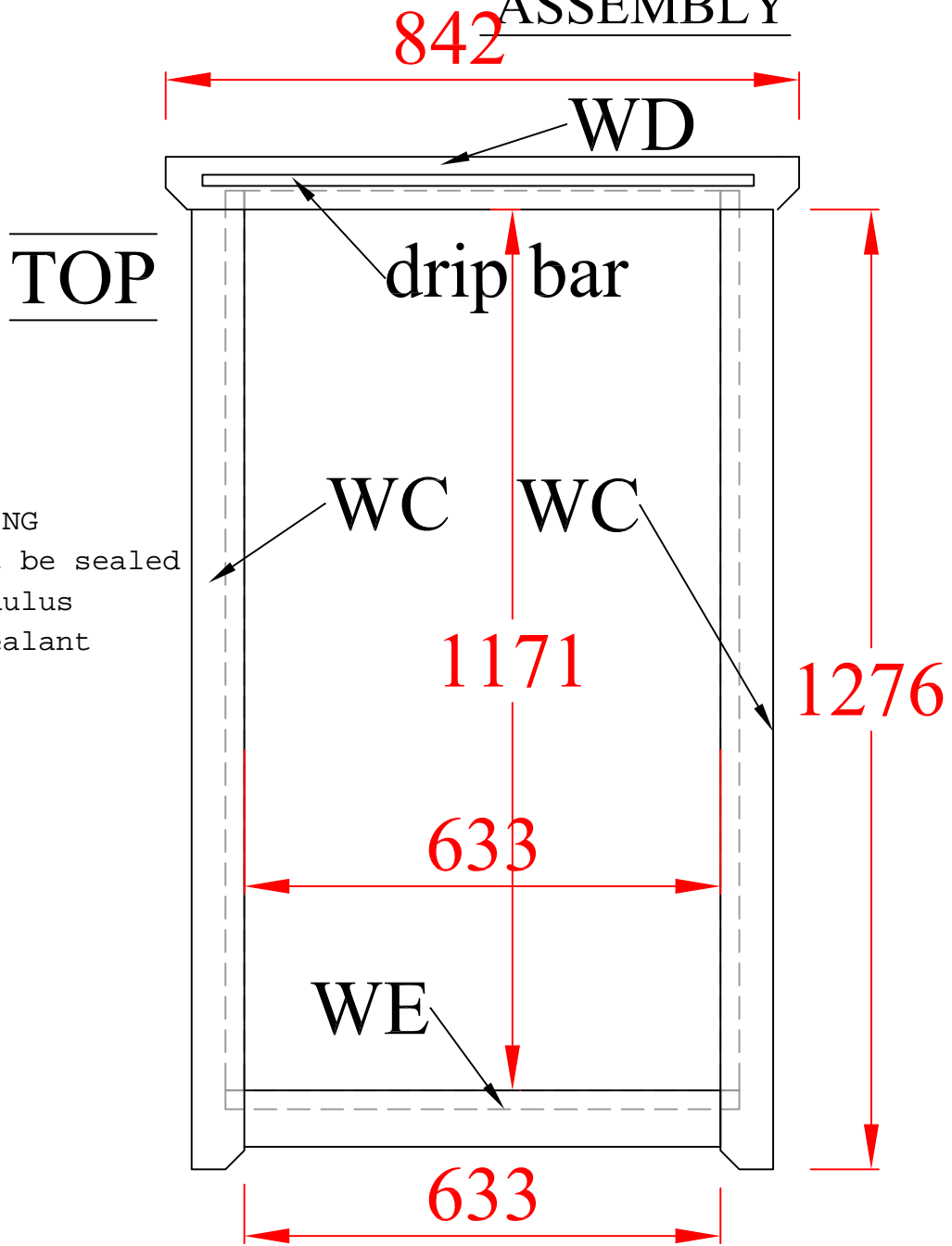

Do not screw
frame into logs

Base details & Floor bearer layout

see page 2 for spacing

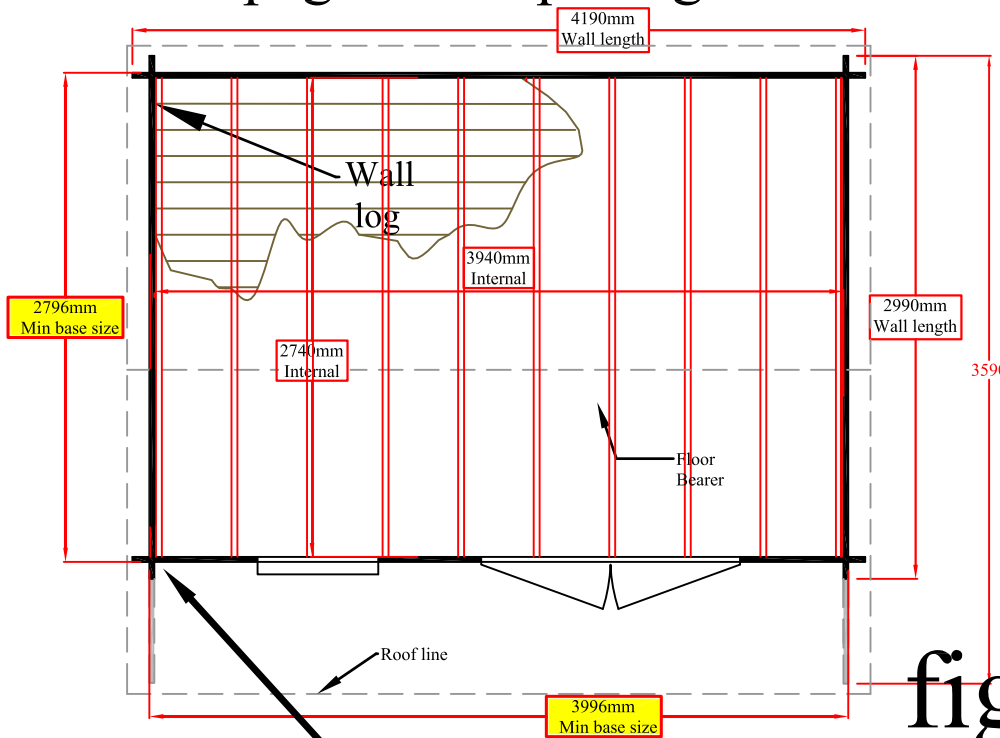

page 1

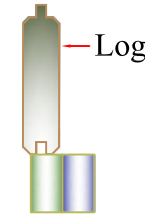

Fig 2
Detail of log sitting on floor joists running parallel to floor bearers

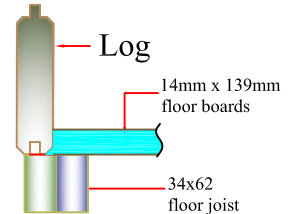

Fig 3
Detail showing floorboard on joist

- 2990x4190(10x14)
- 28mm log
- FLOOR PLAN
- Pressure treated
- Floor joists 38x63
- 12x 2796
- Floor boards
- 20 x 3940

fig 1

Roof Materials

page 6

IMPORTANT

the roof edgings are screwed directly onto the ends of the logs with 4x80mm screws
see pictures

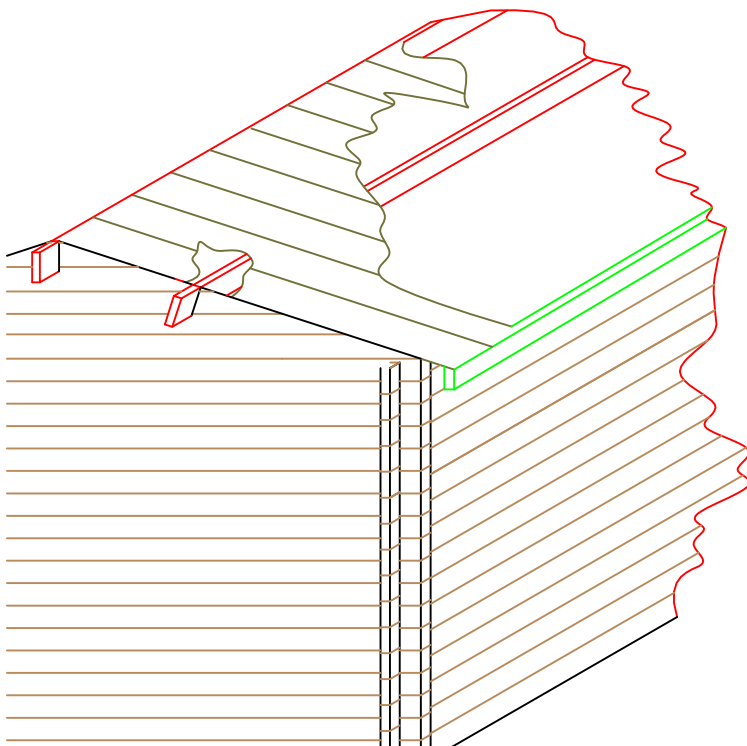

- 2990x4190(10x14)
- 28mm log
- ROOF ASSY
- Parts list

4 6x2 Roof bearers

2 Angled eaves edging strips

2 Angled roof edgings
60 Roof boards
1935 Long

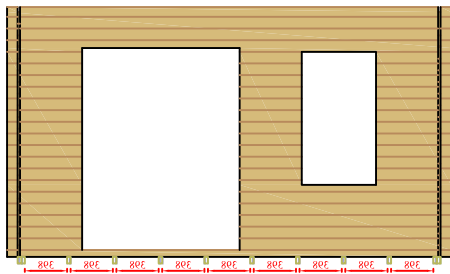

To build opposite hand
just swap logs around

page 2

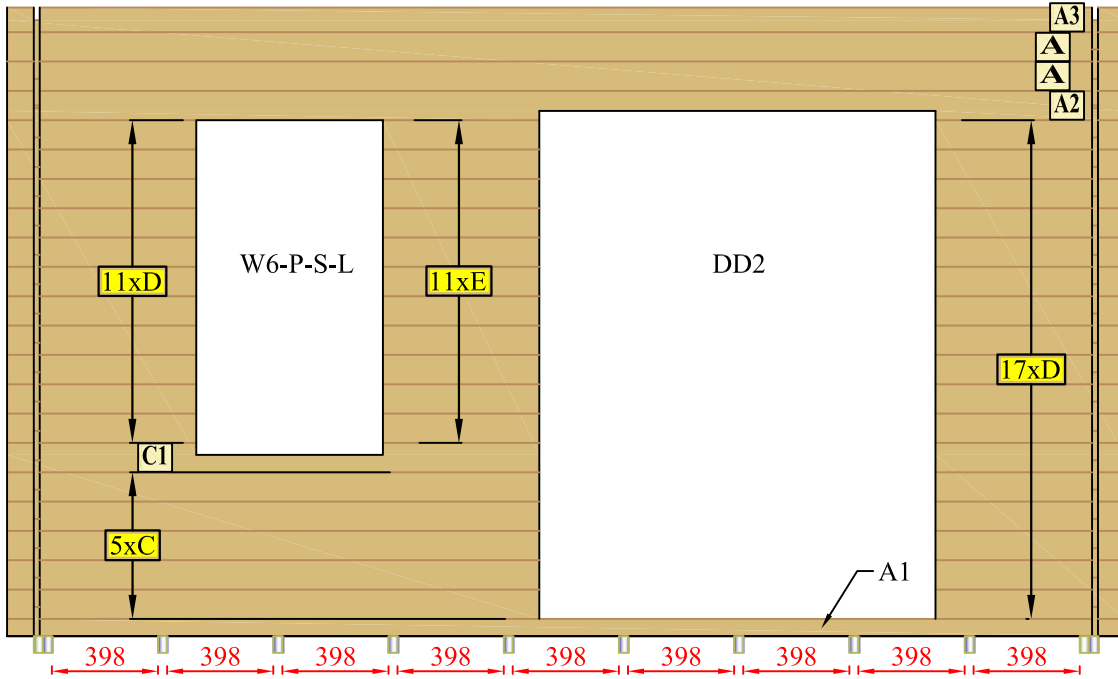

Marlborough
2990x4190(10x14)
28mm log

FRONT

Parts list

Ax2

A1x1

A2x1

A3x1

Cx5

C1x1

Dx28

Ex11

bearer spacing

page 3



2990x4190(10x14)
28mm log

BACK

Parts list

Ax19

A1x1

page 4

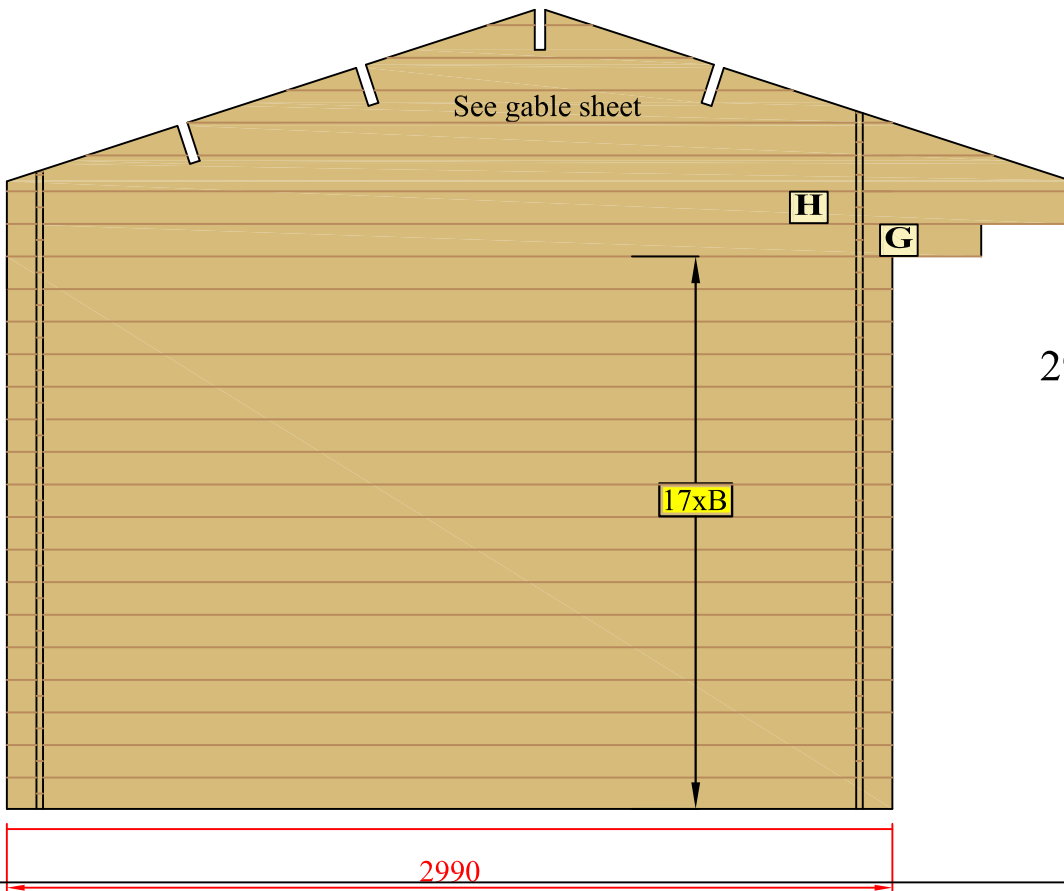

2990x4190(10x14)
28mm log
LH SIDE
Parts list
Bx17
Gx1
Hx1

page 5

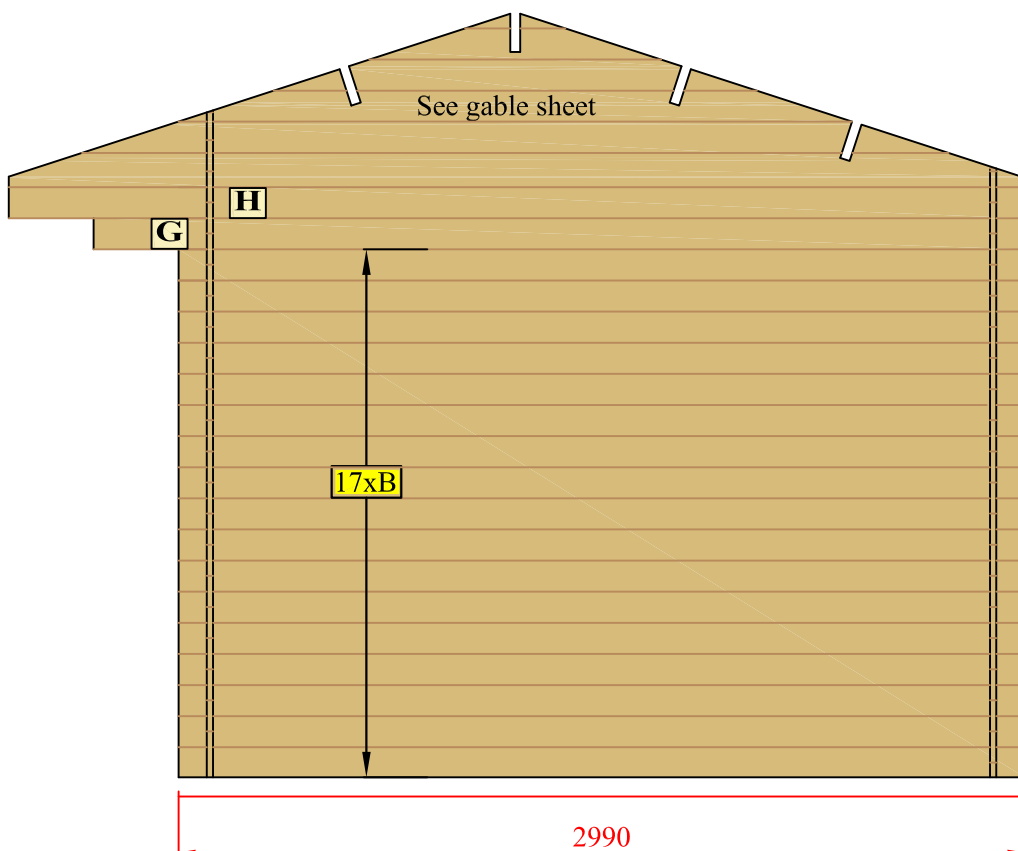

2990x4190(10x14)
28mm log
RH SIDE
Parts list
Bx17
Gx1
Hx1