

Leather Office Chair

If you have any questions about the leather office chair, please feel free to contact us.

Customer Service Email: hgeurope@outlook.com

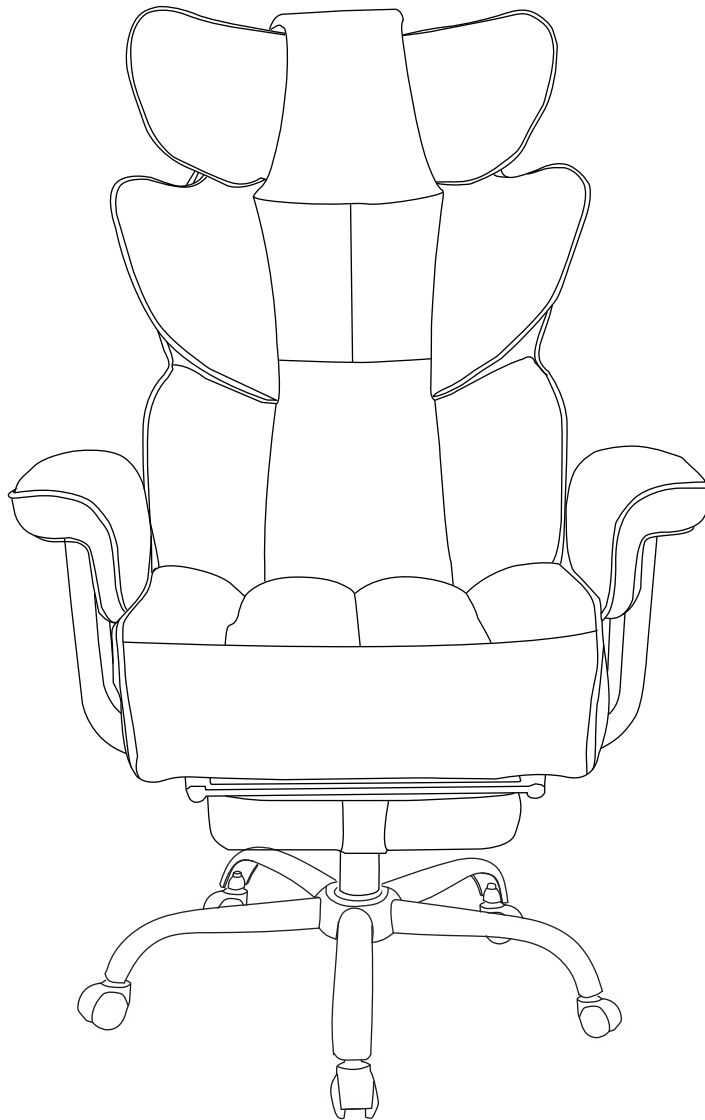

P25053D1

IMPORTANT

PLEASE READ BEFORE YOU COMMENCE ASSEMBLY

Follow the guidelines in this user guide to ensure correct assembly and care for this product.

SPECIFICATIONS

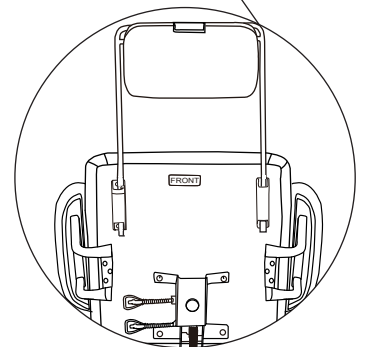
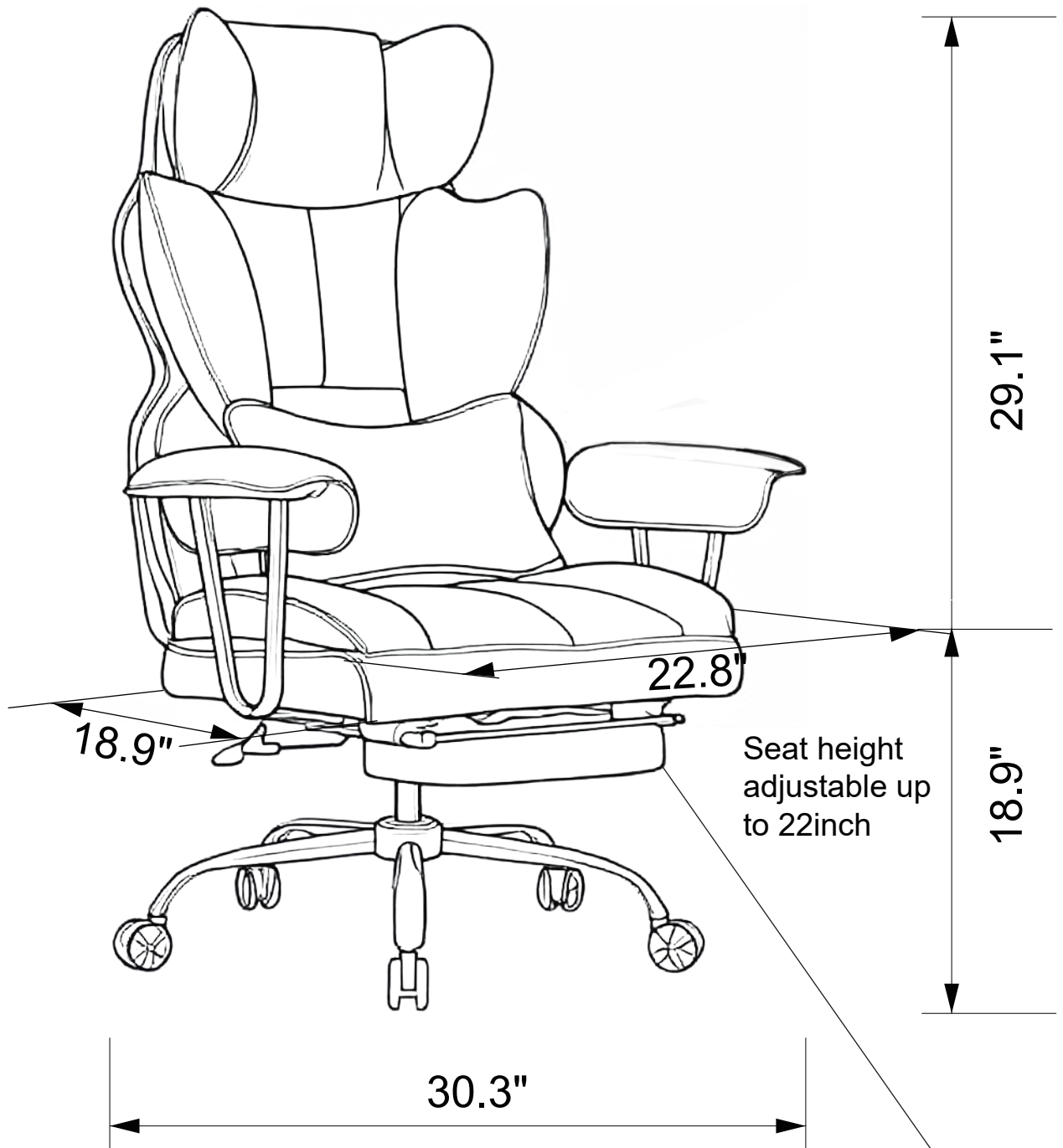

Maximum extension of 35 inch from the top of the footrest to the bottom of the seat when the footrest is pulled out.

Catalog

Specifications..... 01

Catalog..... 02

Care & Instructions 03

Part List And Screw Set List..... 04

How to Use The Leather Office Chair 06



Before You Begin

Assembly Instructions:

Instructions are supplied in this manual and contain all appropriate information for your building model.

Review all instructions before you begin and during assembly, follow the step sequence carefully for correct results.

Parts and Parts List:

Check to be sure that you have all the necessary parts for building.

Separate contents of the carton by the part number while reviewing parts list.

Familiarize yourself with the hardware and fasteners for easier use during construction.

The first few steps show how to join related parts which is to obtain larger sub-assemblies be used later.

All parts are packaged within the carton.



Note that extra fasteners have been supplied for your convenience.

If you have any questions about the leather office chair, please feel free to contact us.

Customer Service Email: hgeurope@outlook.com



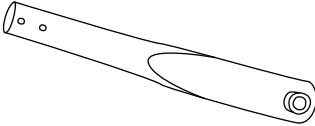
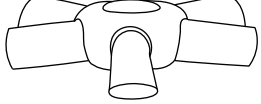

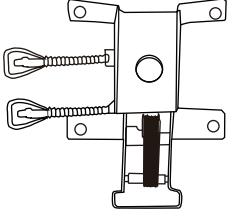
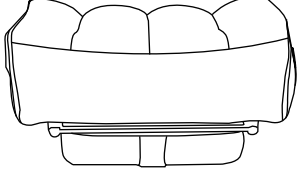
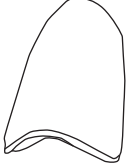
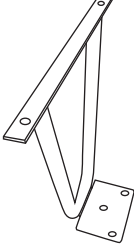
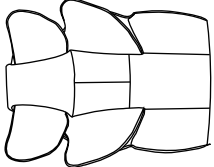
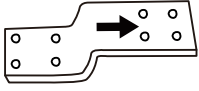
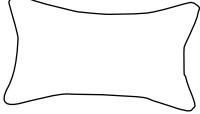



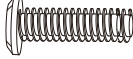

PART LIST

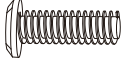
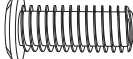
Parts List

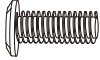
<p>L001</p>  <p>Racing Chair Wheel</p>	<p>L002</p>  <p>Chassis Support Rods</p>	<p>L003</p>  <p>Five-star Feet</p>
<p>5 PCS</p>	<p>5 PCS</p>	<p>1 PC</p>
<p>L004</p>  <p>Cylinder Rod</p>	<p>L005</p>  <p>Adjustment Base</p>	<p>L006</p>  <p>Cushion</p>
<p>1 PC</p>	<p>1 PC</p>	<p>1 PC</p>
<p>L007</p>  <p>Handrail planes</p>	<p>L008</p>  <p>Handrail support bars</p>	<p>L009</p>  <p>Backrest</p>
<p>2 PCS</p>	<p>2 PCS</p>	<p>1 PC</p>
<p>L010</p>  <p>Metal Connection Tab</p>	<p>L011</p>  <p>Lumbar Pillow</p>	
<p>1 PC</p>	<p>1 PC</p>	

PART LIST

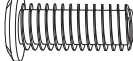
Screw Set List

<p>(K)</p>  <p>M6x16</p>	<p>(L)</p>  <p>M6x25</p>	<p>(M)</p>  <p>M6x20</p>
<p>14 PCS</p>	<p>4 PCS</p>	<p>4 PCS</p>
<p>(N)</p>  <p>M6x20</p>	<p>(O)</p>  <p>M8x20</p>	<p>(P)</p> 
<p>6 PCS</p>	<p>4 PCS</p>	<p>1 PC</p>
<p>Extra (Screw Set)</p>		
<p>(K)</p>  <p>M6x16</p>	<p>(L)</p>  <p>M6x25</p>	<p>(M)</p>  <p>M6x20</p>
<p>1 PC</p>	<p>1 PC</p>	<p>1 PC</p>
<p>(N)</p>  <p>M6x20</p>	<p>(O)</p>  <p>M8x20</p>	<p>(P)</p> 
<p>1 PC</p>	<p>1 PC</p>	<p>1 PC</p>

How To Assemble The Leather Office Chair

Step 1: Remove the plastic protective cover on the top of the five-star feet(L003), insert the five chassis support rods(L002) into the five-star feet to the appropriate position, and align the holes of the support rods and the five-star feet.

NOTE: Be careful not to pinch your fingers.

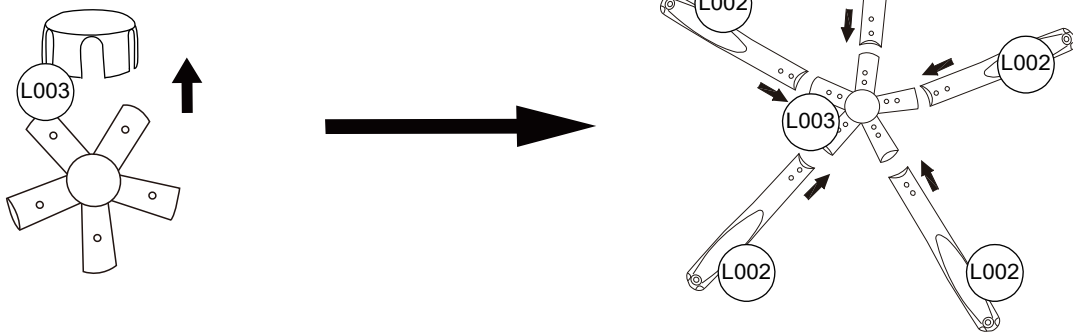

L002



x5

L003

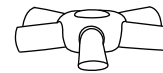

x1

Step 2: Align the screw holes and secure with screws(K). Once securely installed, reattach the plastic cover removed in step 1 to the top of the five-star foot(L003).

NOTE: Be careful not to pinch your fingers and please tighten all screws.

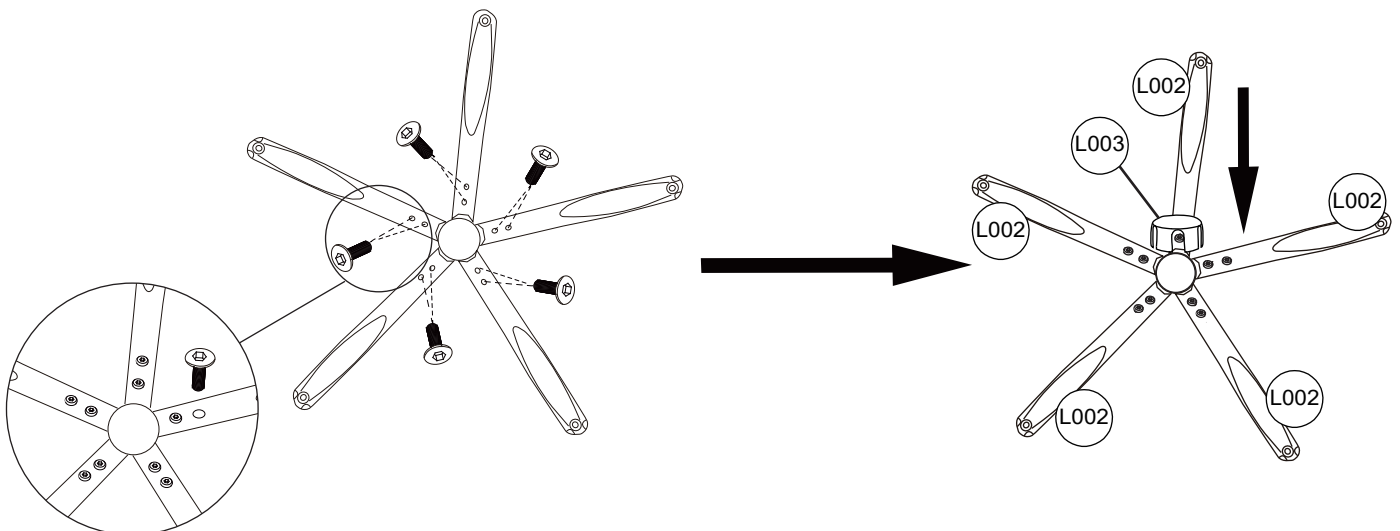

K



M6x16

x10

Installation steps

Step 3:With the bottom of the five-star feet facing up, firmly insert the chair wheel(L001) into the hole of the five-star feet(L002).

NOTE:Be careful not to pinch your fingers.

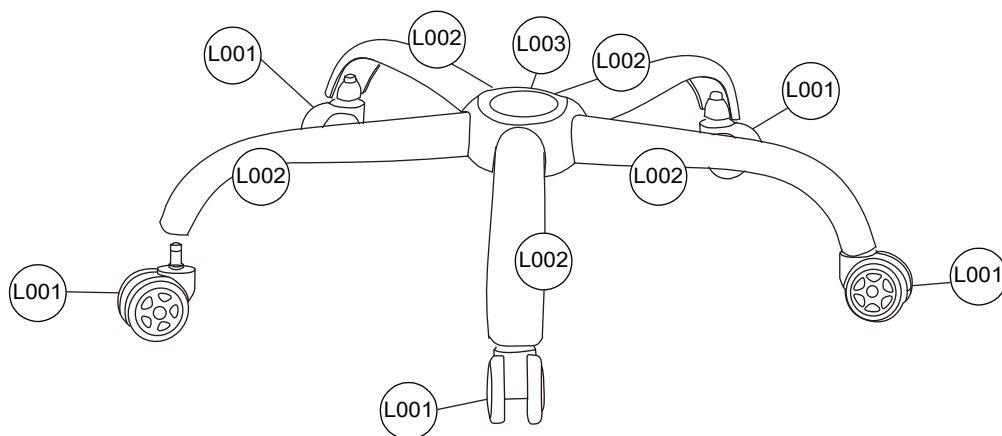

L001



x5

Step 4:Place the five-star feet with the chair wheels installed downward, and insert the bottom of the Cylinder rod(L004) directly into the hole of the five-star feet(L002).

NOTE:Be careful not to pinch your fingers.

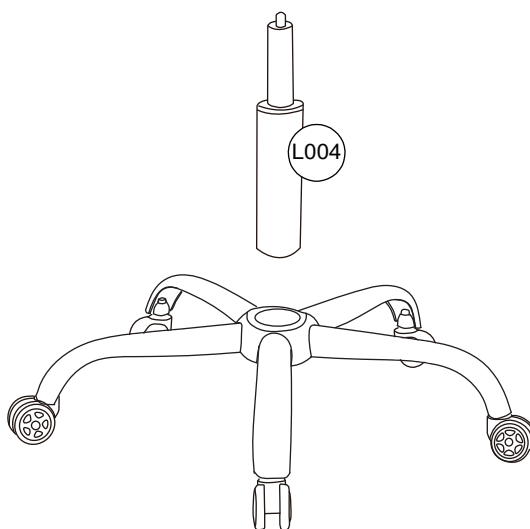

L004







x1

Installation steps

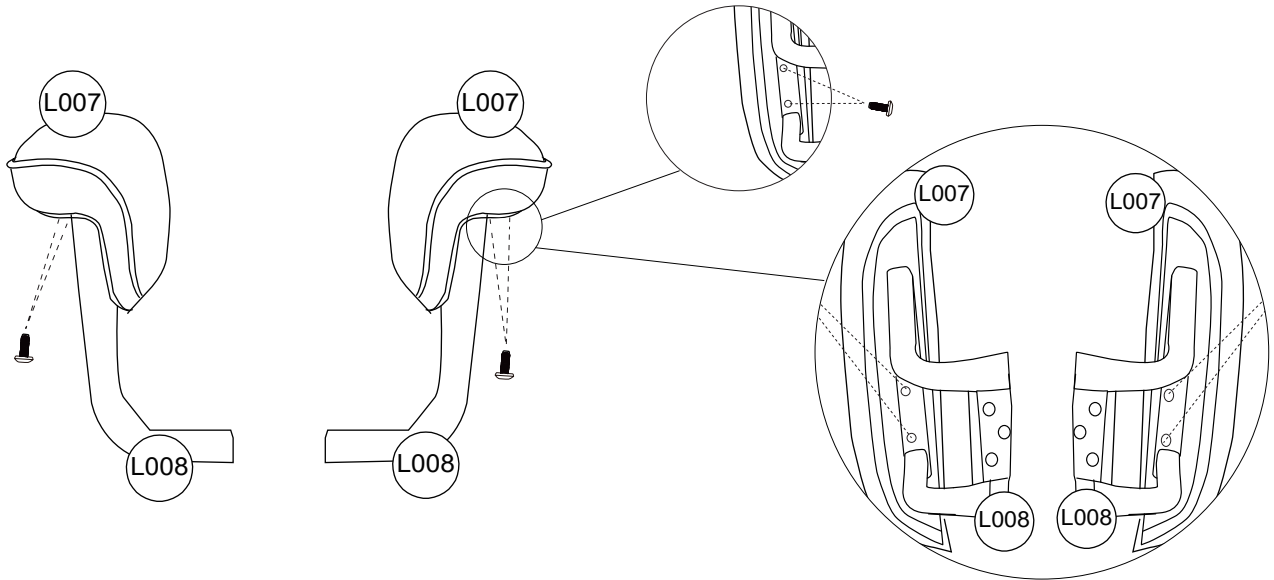
Step 5: Attach the handrail(L007) to the handrail support bar (L008) with screws(K) as shown in the diagram.

NOTE: Be careful not to pinch your fingers. Please pay attention to the direction of installation and please tighten all screws.



L007		x2	L008		x2	K		M6x16mm	x4
------	---	----	------	---	----	---	---	---------	----

Step 6: Secure each of the two armrests installed in step 5 with screws(N) to the corresponding locations on the bottom of the cushion(L006).

NOTE: Be careful not to pinch your fingers. Please pay attention to the direction of installation and please tighten all screws.

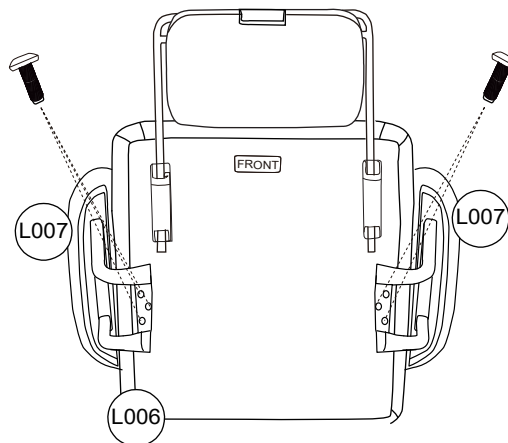

L006		x1	N		M6x20mm	x6
------	---	----	---	---	---------	----

Installation steps

Step 7:Secure the Adjustment Sump(L005) with screws(M) under the cushion (L006)installed in step 6 as shown in the picture.

NOTE:Please pay attention to the direction of installation and please tighten all screws.

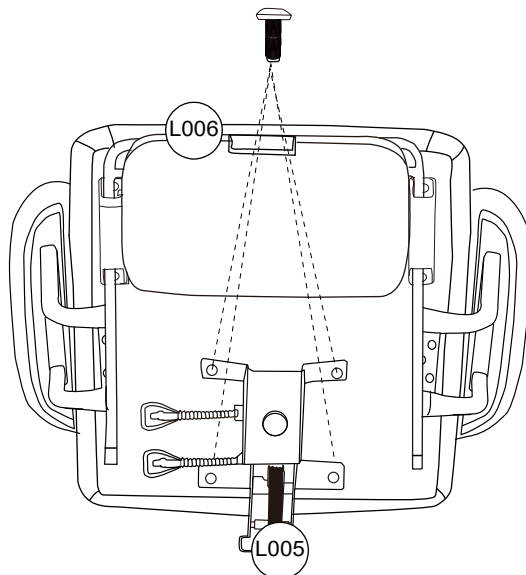

L005

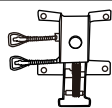

x1

M



M6x20mm

x4

Step 8:Insert the cushion part assembled in step 7 on top of the base part assembled in step 4.

NOTE:Be careful not to pinch your fingers.

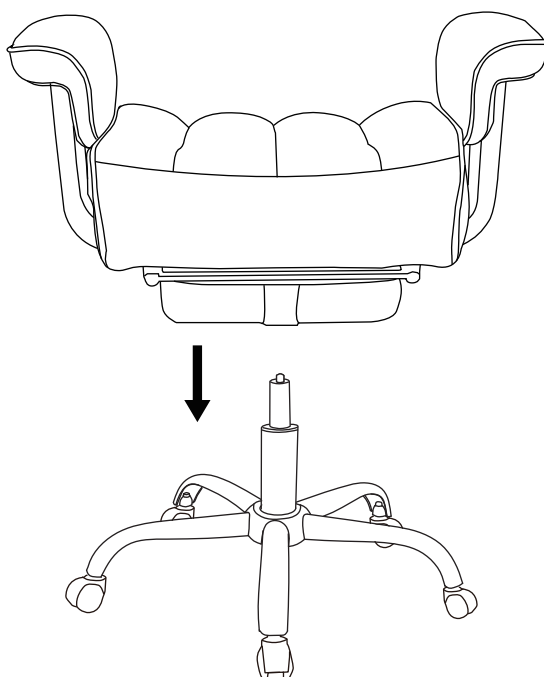

Installation steps

Step 10: Lift the cover plate on the back of the backrest(L009) upwards as shown in the figure and screw the metal connection tab (L010) to the corresponding position on the backrest (L009).

NOTE:Please tighten all screws.

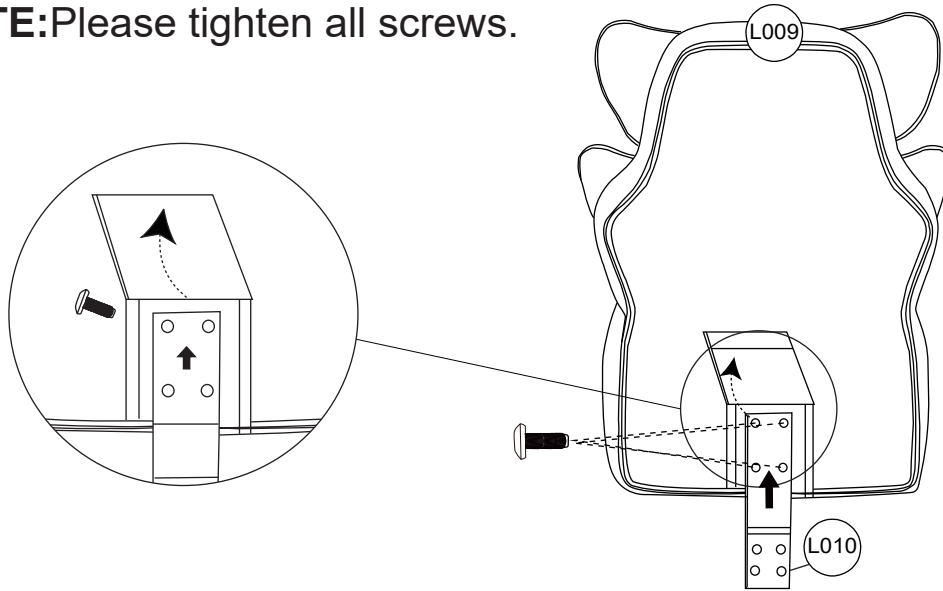

L010

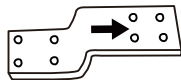

x1

L009

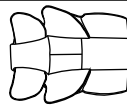

x1

L



M6x25mm

x4

Step 11:As shown in the figure, fix the backrest part assembled in step 5 with the base part assembled in step 4 by screws(O) and metal connection tab(L010).

NOTE:Please tighten all screws.

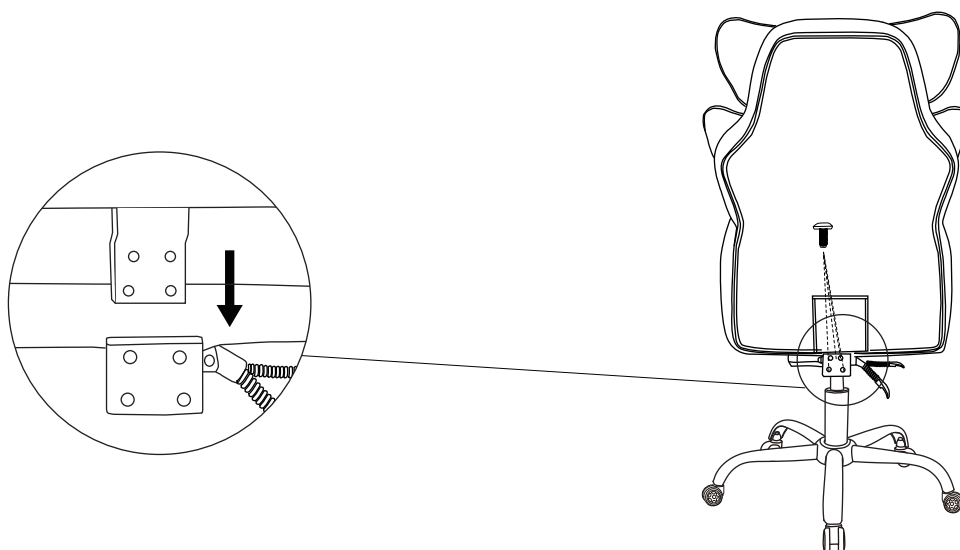

O

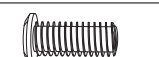
M8x20mm

x4

Installation steps

Step 12: Put the cushion, the installation is complete.

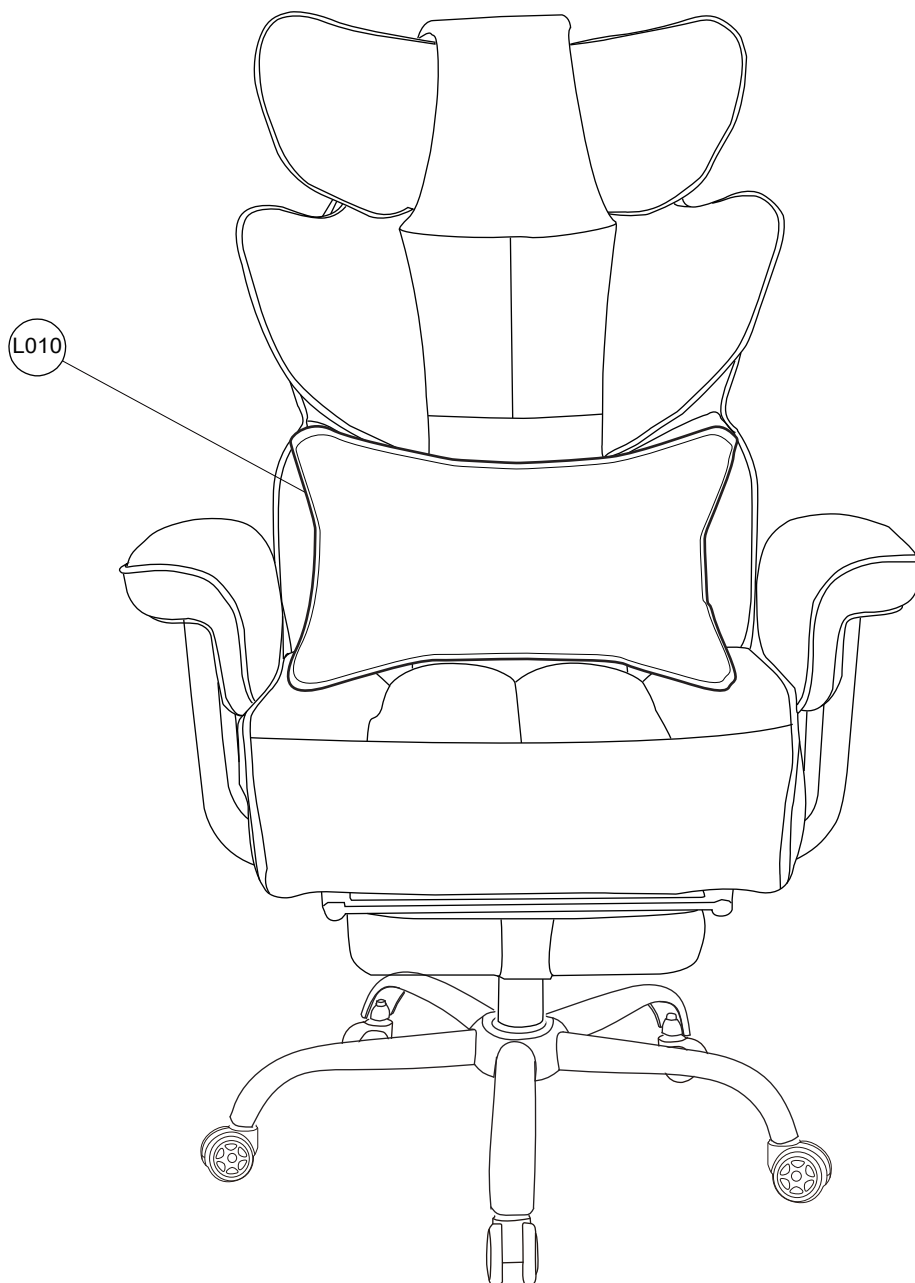

L011

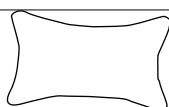

x1

Leder-Bürostuhl

Wenn Sie Fragen zu dem Leder-Bürostuhl haben, können Sie uns gerne kontaktieren.

E-Mail an den Kundendienst: hgeurope@outlook.com

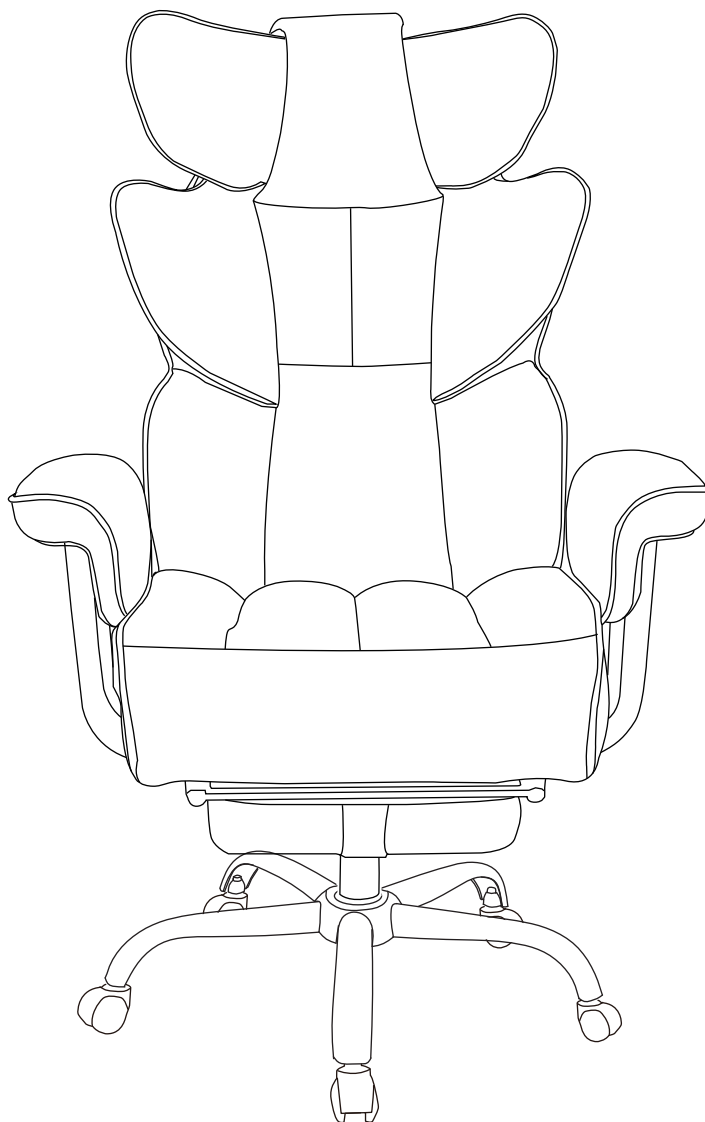

P25053D1

WICHTIG

BITTE VOR BEGINN DER MONTAGE LESEN

Befolgen Sie die Richtlinien in diesem Benutzerhandbuch, um eine korrekte Montage und Pflege dieses Produkts zu gewährleisten.

SPEZIFIKATIONEN

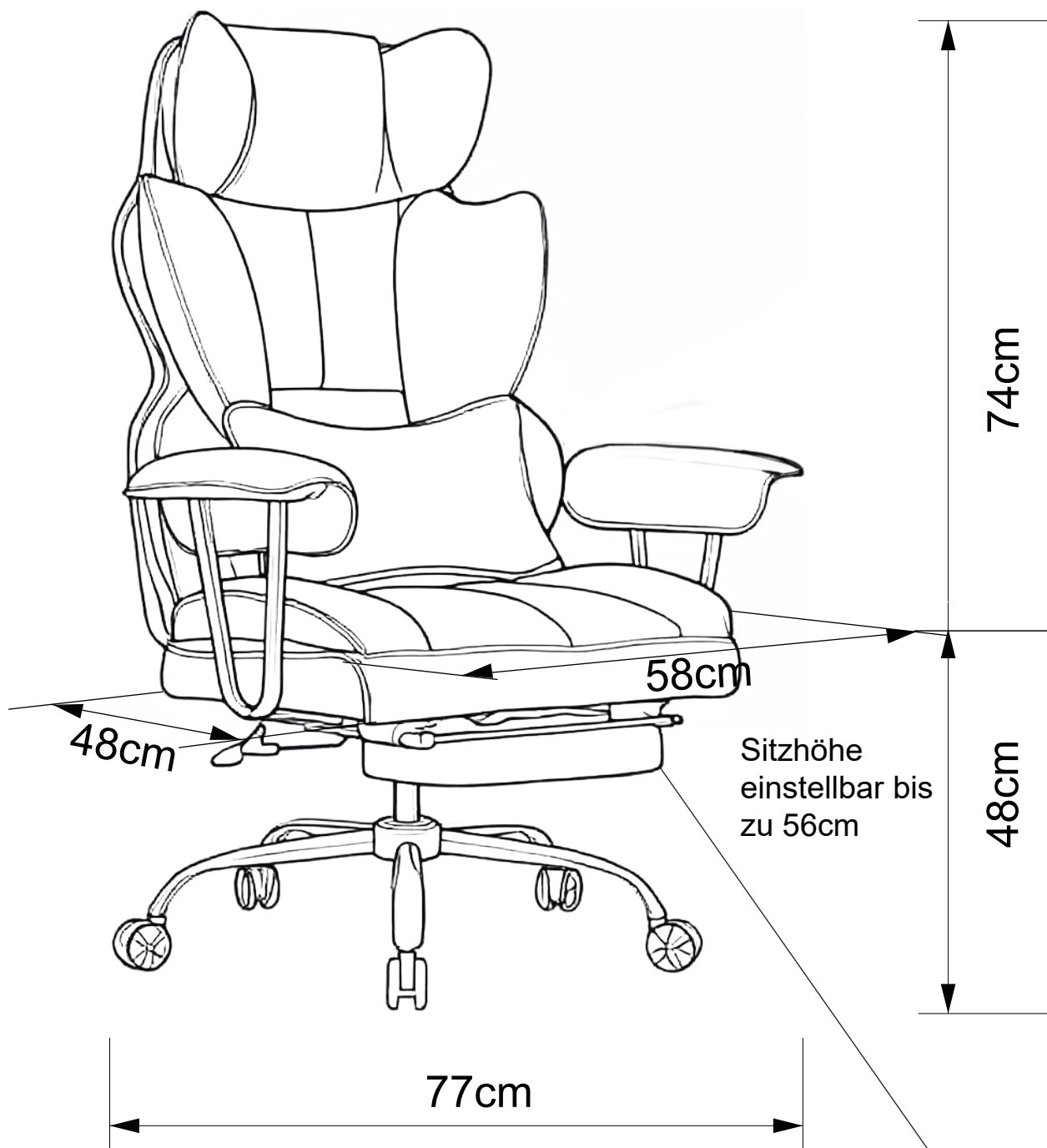

Maximale Länge von 89 cm von der Oberkante der Fußstütze bis zur Unterkante des Sitzes, wenn die Fußstütze ausgezogen ist.

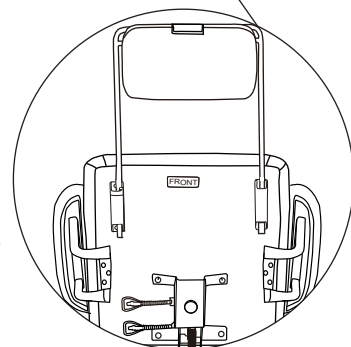

Katalog

Spezifikationen.....	01
Katalog.....	02
Pflege & Anleitung	03
Teileliste & Schraubensatzliste.....	04
Wie man den Leder-Bürostuhl benutzt	06



Bevor Sie beginnen

Montageanleitung:

Die Anleitung ist in diesem Handbuch enthalten und enthält alle für Ihr Gebäudemodell relevanten Informationen.

Lesen Sie alle Anweisungen durch, bevor Sie mit der Montage beginnen, und befolgen Sie die Schrittfolge sorgfältig, um korrekte Ergebnisse zu erzielen.

Teile und Teileliste:

Vergewissern Sie sich, dass Sie alle für den Bau erforderlichen Teile haben.

Trennen Sie den Inhalt des Kartons nach der Teilenummer, während Sie die Teileliste durchsehen.

Machen Sie sich mit den Beschlägen und Befestigungselementen vertraut, um die Verwendung während der Konstruktion zu erleichtern.

In den ersten Schritten wird gezeigt, wie zusammengehörige Teile zusammengefügt werden, um später größere Unterbaugruppen zu erhalten.

Alle Teile sind im Karton verpackt.



Bitte beachten Sie, dass zusätzliche Befestigungselemente mitgeliefert wurden, um Ihnen die Arbeit zu erleichtern.

Wenn Sie Fragen zu dem Leder-Bürostuhl haben, können Sie uns gerne kontaktieren.

Kundenservice E-Mail: hgeurope@outlook.com



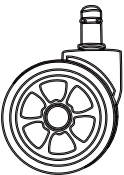
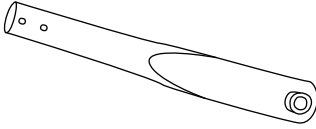
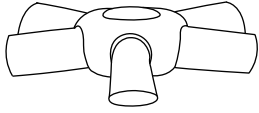

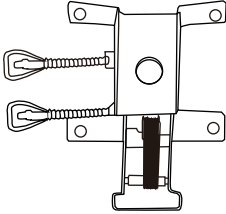
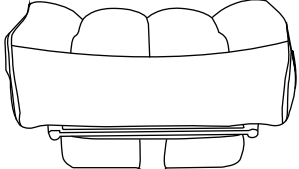
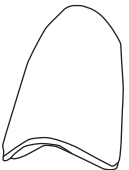
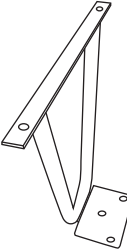
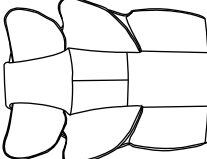
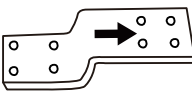
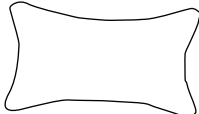



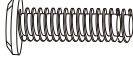

TEILELISTE

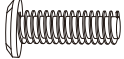
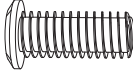
Teileliste

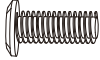
<p>L001</p>  <p>Rennsessel-Rad</p>	<p>L002</p>  <p>Fahrgestell-Stützstangen</p>	<p>L003</p>  <p>Fünf-Sterne-FüÙe</p>
<p>5 PCS</p>	<p>5 PCS</p>	<p>1 PC</p>
<p>L004</p>  <p>Cylinder Rod</p>	<p>L005</p>  <p>Einstellung Basis</p>	<p>L006</p>  <p>Kissen</p>
<p>1 PC</p>	<p>1 PC</p>	<p>1 PC</p>
<p>L007</p>  <p>Handlaufebenen</p>	<p>L008</p>  <p>Haltestangen für Geländer</p>	<p>L009</p>  <p>Rückenlehne</p>
<p>2 PCS</p>	<p>2 PCS</p>	<p>1 PC</p>
<p>L010</p>  <p>Verbindungsflasche aus Metall</p>	<p>L011</p>  <p>Lendenkissen</p>	
<p>1 PC</p>	<p>1 PC</p>	

TEILELISTE

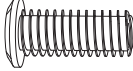
Schraubensatzliste

<p>(K)</p>  <p>M6x16</p>	<p>(L)</p>  <p>M6x25</p>	<p>(M)</p>  <p>M6x20</p>
<p>14 PCS</p>	<p>4 PCS</p>	<p>4 PCS</p>
<p>(N)</p>  <p>M6x20</p>	<p>(O)</p>  <p>M8x20</p>	<p>(P)</p> 
<p>6 PCS</p>	<p>4 PCS</p>	<p>1 PC</p>
<p>Extra (Schraubensatz)</p>		
<p>(K)</p>  <p>M6x16</p>	<p>(L)</p>  <p>M6x25</p>	<p>(M)</p>  <p>M6x20</p>
<p>1 PC</p>	<p>1 PC</p>	<p>1 PC</p>
<p>(N)</p>  <p>M6x20</p>	<p>(O)</p>  <p>M8x20</p>	<p>(P)</p> 
<p>1 PC</p>	<p>1 PC</p>	<p>1 PC</p>

Wie man den Leder-Bürostuhl zusammenbaut

Schritt 1: Entfernen Sie die Kunststoff-Schutzabdeckung auf der Oberseite der Fünf-Sterne-Füße (L003), setzen Sie die fünf Chassis-Stützstangen (L002) in die Fünf-Sterne-Füße in der entsprechenden Position ein, und richten Sie die Löcher der Stützstangen und der Fünf-Sterne-Füße aus.

HINWEIS: Achten Sie darauf, dass Sie sich nicht die Finger einklemmen.

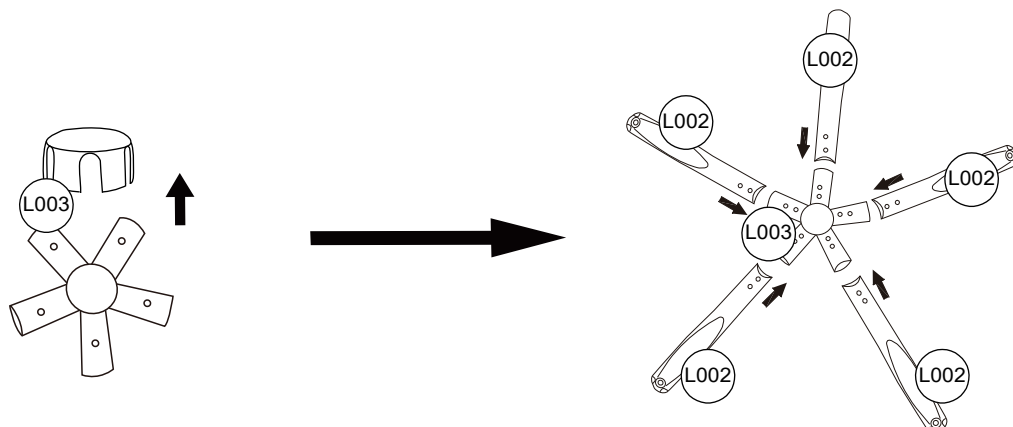

L002



x5

L003

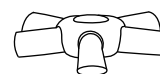

x1

Schritt 2: Richten Sie die Schraubenlöcher aus und befestigen Sie sie mit den Schrauben (K). Bringen Sie die in Schritt 1 entfernte Kunststoffabdeckung wieder an der Oberseite des Fünf-Sterne-Fußes (L003) an, sobald sie fest installiert ist.

HINWEIS: Achten Sie darauf, dass Sie sich nicht die Finger einklemmen, und ziehen Sie bitte alle Schrauben fest.

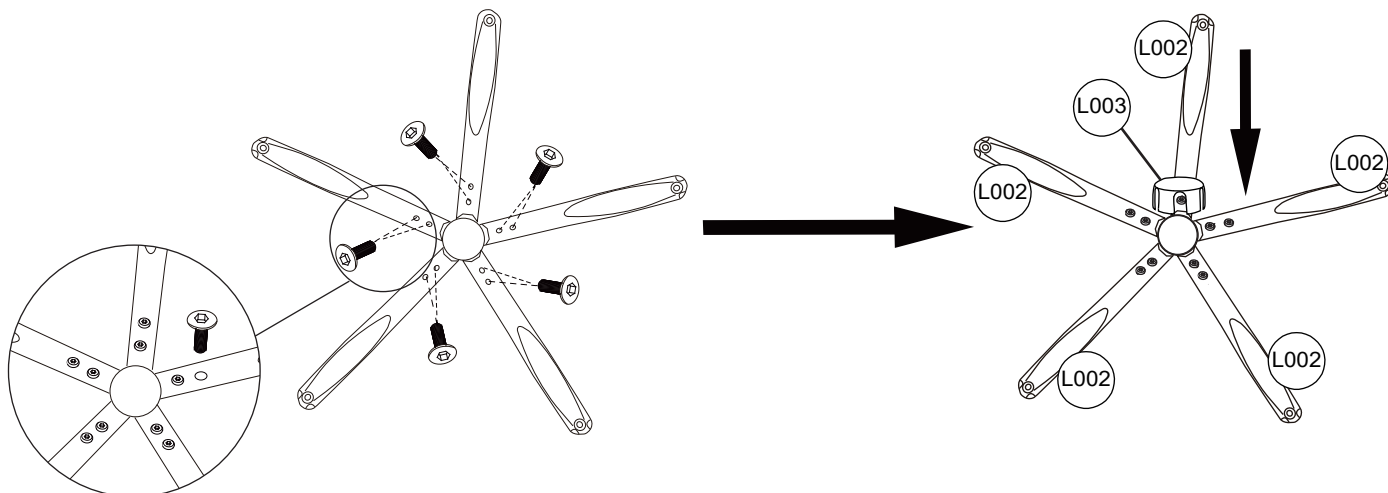

K



M6x16

x10

Schritt 3: Stecken Sie das Stuhlrad (L001) mit der Unterseite der Fünfsternefüße nach oben fest in das Loch der Fünfsternefüße (L002).

HINWEIS: Achten Sie darauf, dass Sie sich nicht die Finger einklemmen.

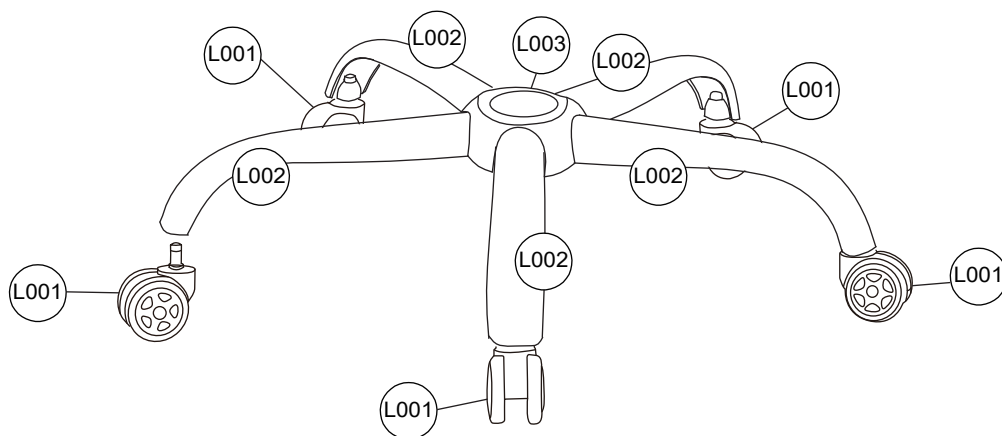

L001



x5

Schritt 4: Stellen Sie die Fünfsternefüße mit den montierten Stuhlrädern nach unten und stecken Sie die Unterseite der Zylinderstange (L004) direkt in das Loch der Fünfsternefüße (L002).

HINWEIS: Achten Sie darauf, dass Sie sich nicht die Finger einklemmen.

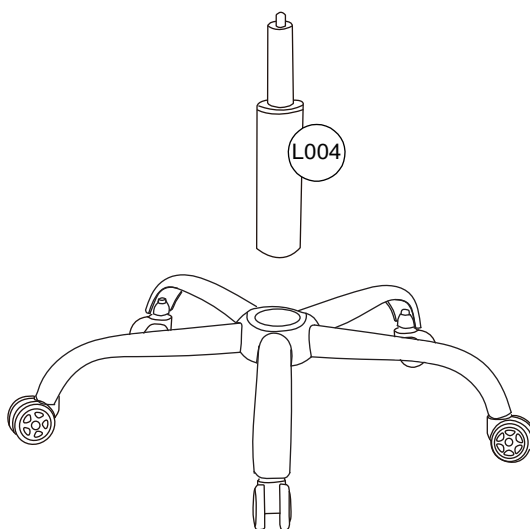

L004



x1

Schritt 5: Befestigen Sie den Handlauf (L007) mit den Schrauben (K) wie in der Abbildung gezeigt an der Handlaufhalterung (L008).

HINWEIS: Achten Sie darauf, dass Sie sich nicht die Finger einklemmen, und ziehen Sie alle Schrauben fest.

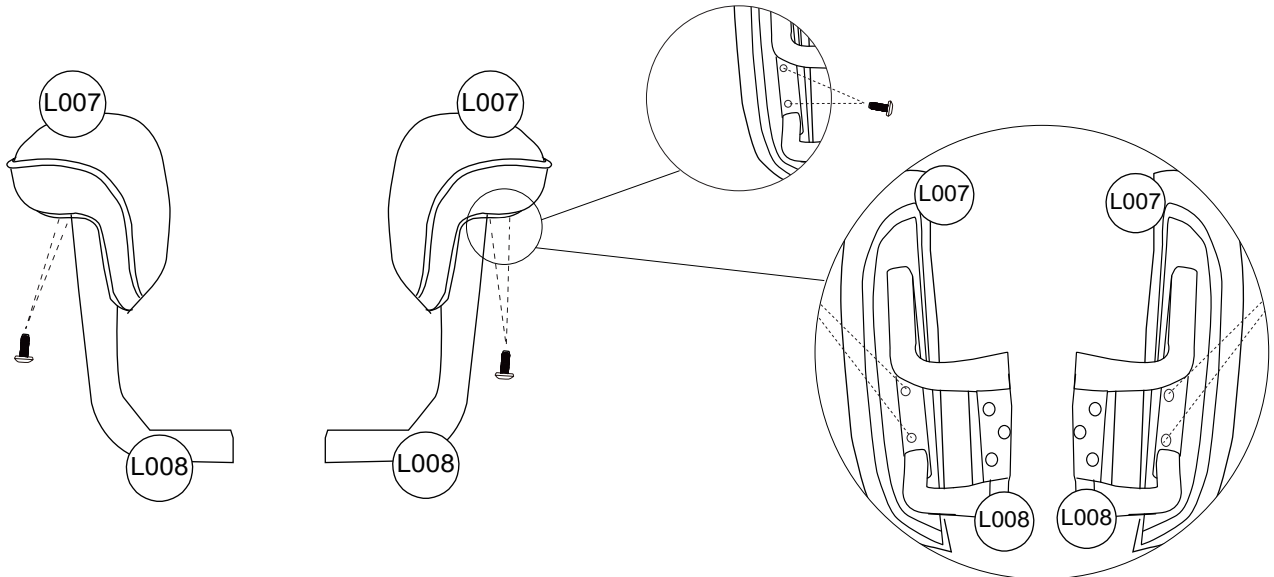

L007



x2

L008



x2

K



M6x16mm

x4

Schritt 6: Befestigen Sie jede der beiden in Schritt 5 montierten Armlehnen mit Schrauben (N) an den entsprechenden Stellen an der Unterseite des Kissens (L006).

HINWEIS: Achten Sie darauf, dass Sie sich nicht die Finger einklemmen, und ziehen Sie alle Schrauben fest.

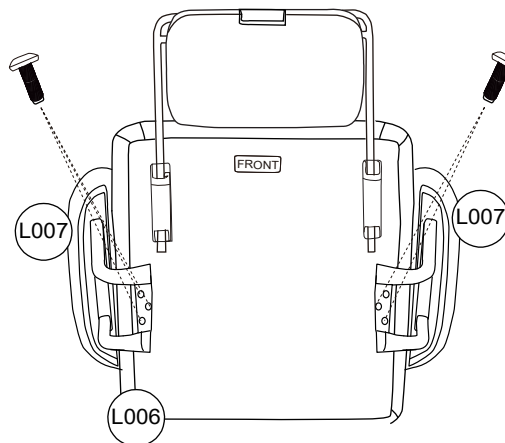

L006

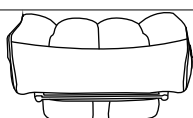

x1

N

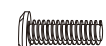

M6x20mm

x6

Schritt 7: Befestigen Sie die Einstellwanne (L005) mit Schrauben (M) unter dem in Schritt 6 installierten Kissen (L006), wie in der Abbildung gezeigt.

HINWEIS: Achten Sie bitte auf die Einbaurichtung und ziehen Sie alle Schrauben fest.

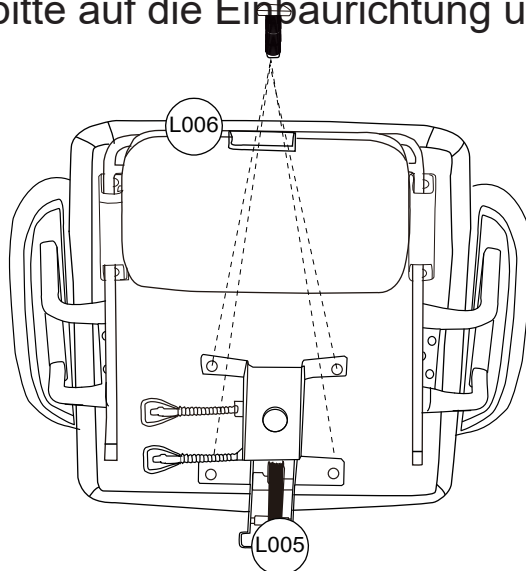

L005

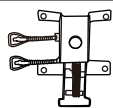

x1

M



M6x20mm

x4

Schritt 8: Setzen Sie das in Schritt 7 zusammengebaute Polsterteil auf das in Schritt 4 zusammengebaute Basisteil.

HINWEIS: Achten Sie darauf, dass Sie sich nicht die Finger einklemmen.

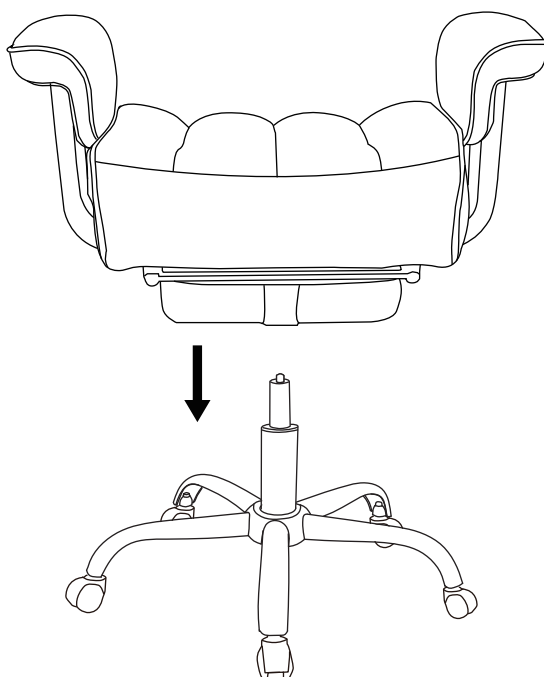

Schritt 10: Heben Sie die Abdeckplatte auf der Rückseite der Rückenlehne (L009) wie in der Abbildung gezeigt nach oben und schrauben Sie die Metallverbindungslasche (L010) an die entsprechende Stelle der Rückenlehne (L009).

HINWEIS: Bitte ziehen Sie alle Schrauben fest.

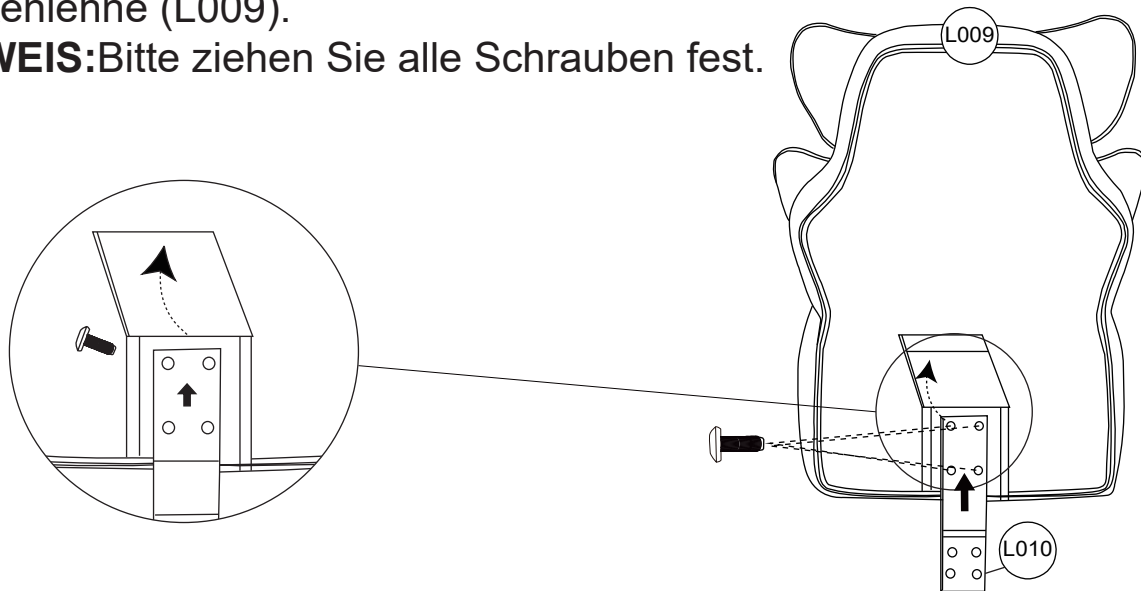

L010

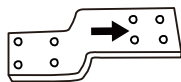

x1

L009

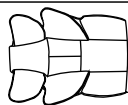

x1

L

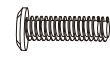

M6x25mm

x4

Schritt 11: Befestigen Sie, wie in der Abbildung gezeigt, das in Schritt 5 zusammengebaute Rückenteil mit dem in Schritt 4 zusammengebauten Basisteil durch Schrauben (O) und Metallverbindungslaschen (L010).

HINWEIS: Bitte ziehen Sie alle Schrauben fest.

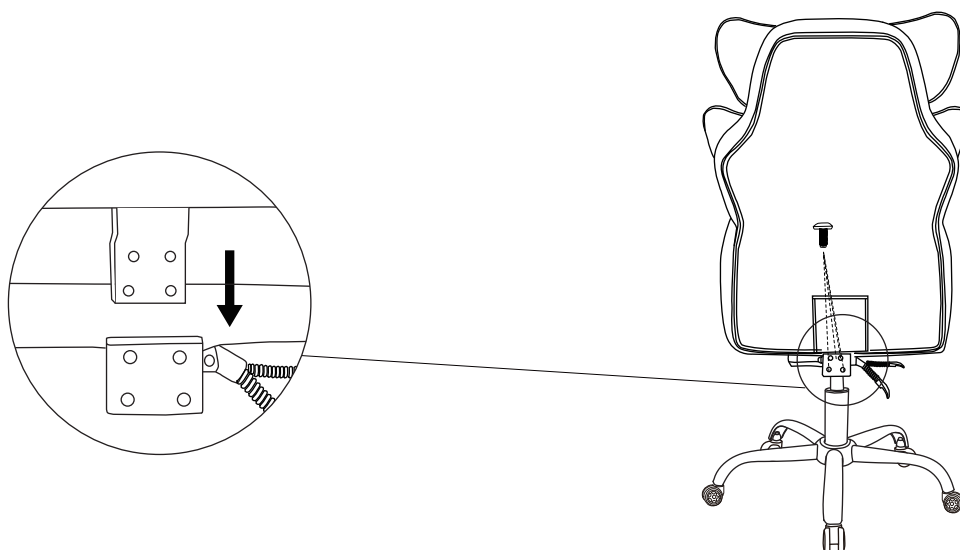

O

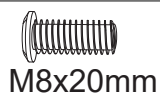

M8x20mm

x4

Schritt 12: Legen Sie das Kissen, die Installation ist abgeschlossen.

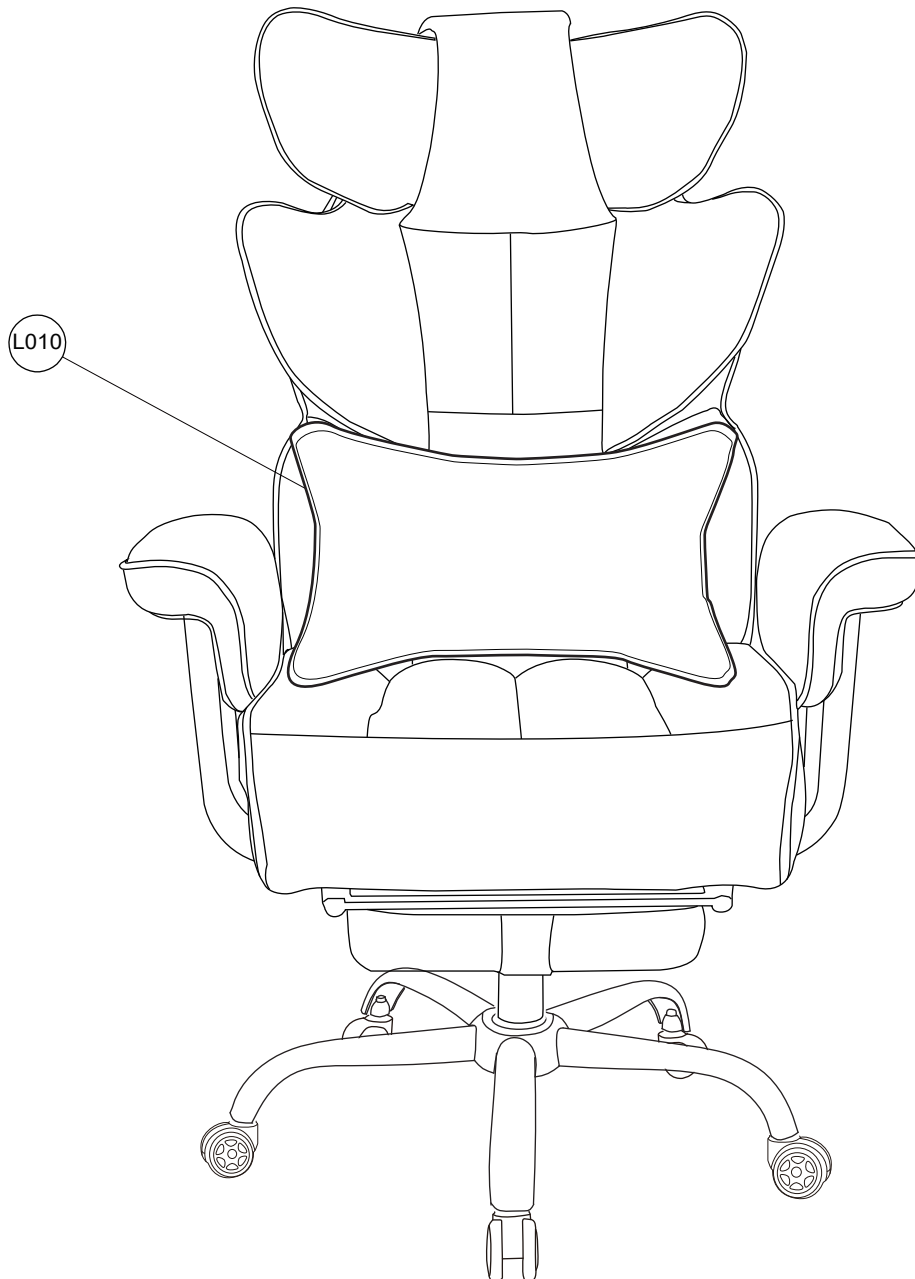

L011

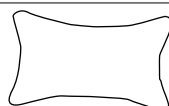

x1

Chaise de bureau en cuir

Si vous avez des questions sur la chaise de bureau en cuir, n'hésitez pas à nous contacter.

Courriel du service clientèle : hgeurope@outlook.com

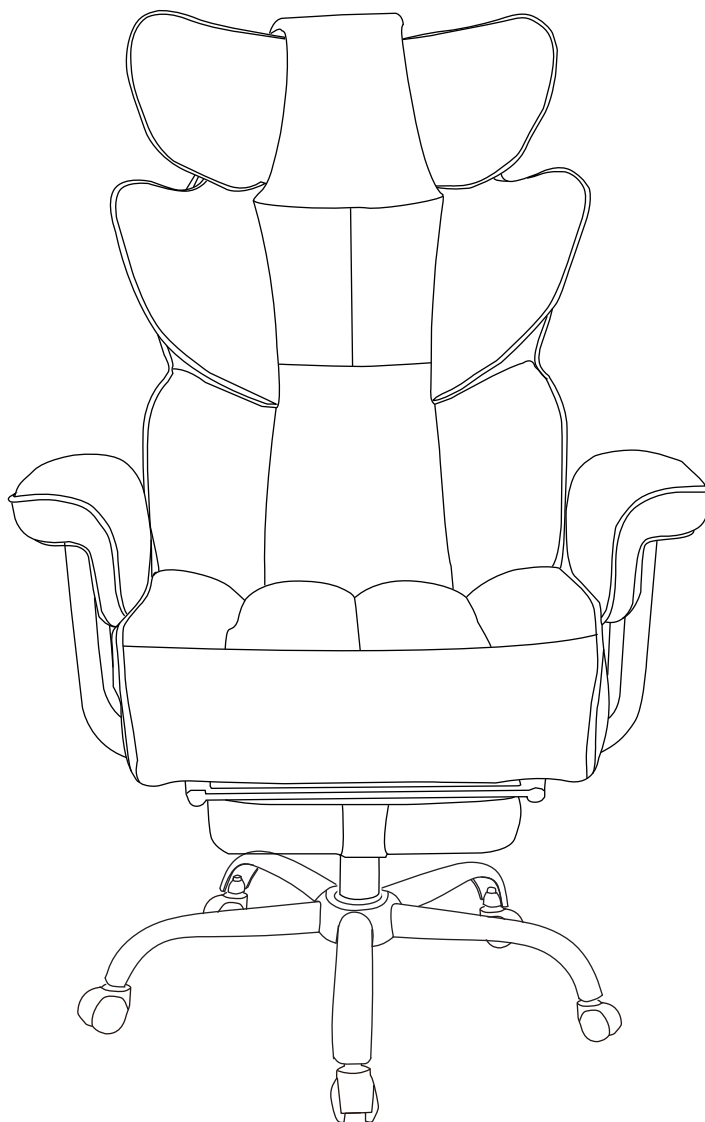

P25053D1

IMPORTANT

À LIRE AVANT DE COMMENCER L'ASSEMBLAGE

Suivez les directives de ce guide de l'utilisateur pour assurer un assemblage et un entretien corrects de ce produit.

CARACTÉRISTIQUES TECHNIQUES

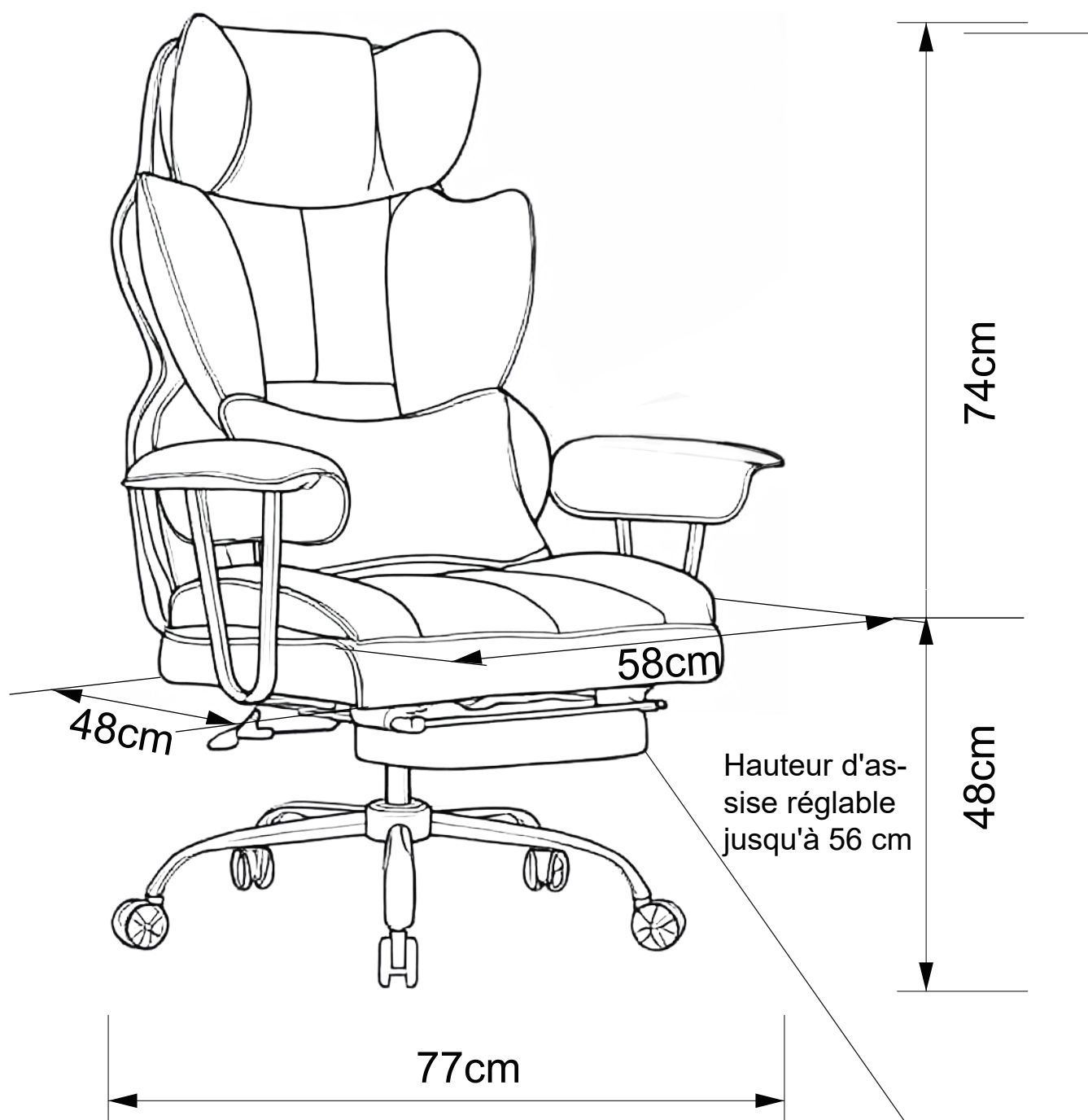

Extension maximale de 89 cm
entre le haut du repose-pieds et le bas
de l'assise lorsque le repose-pieds est

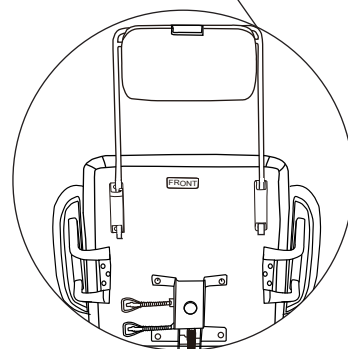

Catalogue

Spécifications.....	01
Catalogue.....	02
Soins et instructions	03
Liste des pièces et des jeux de vis.....	04
Comment utiliser la chaise de bureau en cuir	06



Avant de commencer

Instructions de montage :

Les instructions sont fournies dans ce manuel et contiennent toutes les informations appropriées pour votre modèle de construction.

Lisez toutes les instructions avant de commencer et pendant le montage, suivez attentivement l'ordre des étapes pour obtenir des résultats corrects.

Pièces et liste des pièces :

Vérifiez que vous disposez de toutes les pièces nécessaires à la construction.

Séparer le contenu du carton en fonction du numéro de pièce tout en examinant la liste des pièces.

Familiarisez-vous avec la quincaillerie et les fixations pour les utiliser plus facilement pendant la construction.

Les premières étapes montrent comment assembler des pièces connexes afin d'obtenir des sous-ensembles plus grands qui seront utilisés ultérieurement.

Toutes les pièces sont emballées dans le carton.





Notez que des fixations supplémentaires ont été fournies pour votre commodité.

Si vous avez des questions sur la chaise de bureau en cuir, n'hésitez pas à nous contacter.



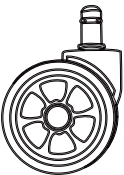
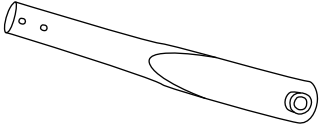
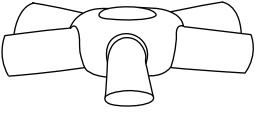

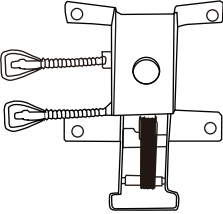
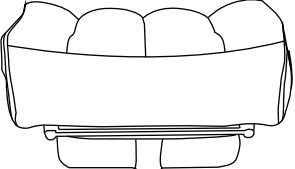

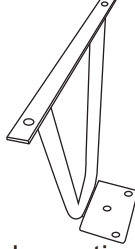
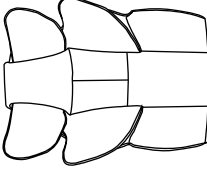
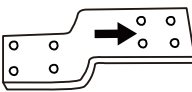
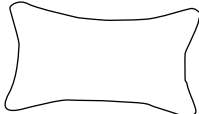

Courriel du service clientèle : hgeurope@outlook.com

LISTE DES PARTIES

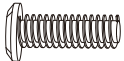
Liste des pièces

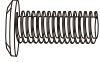
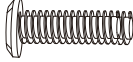
<p>L001</p>  <p>Roue de fauteuil de course</p>	<p>L002</p>  <p>Tiges de support du châssis</p>	<p>L003</p>  <p>Pieds cinq étoiles</p>
<p>5 PCS</p>	<p>5 PCS</p>	<p>1 PC</p>
<p>L004</p>  <p>Cylindre Rod</p>	<p>L005</p>  <p>Base de réglage</p>	<p>L006</p>  <p>Coussin</p>
<p>1 PC</p>	<p>1 PC</p>	<p>1 PC</p>
<p>L007</p>  <p>Plans de la main courante</p>	<p>L008</p>  <p>Barres de soutien de la main courante</p>	<p>L009</p>  <p>Dossier</p>
<p>2 PCS</p>	<p>2 PCS</p>	<p>1 PC</p>
<p>L010</p>  <p>Languette de connexion en métal</p>	<p>L011</p>  <p>Oreiller lombaire</p>	
<p>1 PC</p>	<p>1 PC</p>	

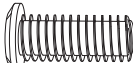
Liste des jeux de vis

<p>(K)</p>  <p>M6x16</p>	<p>(L)</p>  <p>M6x25</p>	<p>(M)</p>  <p>M6x20</p>
<p>14 PCS</p>	<p>4 PCS</p>	<p>4 PCS</p>
<p>(N)</p>  <p>M6x20</p>	<p>(O)</p>  <p>M8x20</p>	<p>(P)</p> 
<p>6 PCS</p>	<p>4 PCS</p>	<p>1 PC</p>
<p>Extra (jeu de vis)</p>		
<p>(K)</p>  <p>M6x16</p>	<p>(L)</p>  <p>M6x25</p>	<p>(M)</p>  <p>M6x20</p>
<p>1 PC</p>	<p>1 PC</p>	<p>1 PC</p>
<p>(N)</p>  <p>M6x20</p>	<p>(O)</p>  <p>M8x20</p>	<p>(P)</p> 
<p>1 PC</p>	<p>1 PC</p>	<p>1 PC</p>

Comment assembler la chaise de bureau en cuir

Étape 1 : Retirez le couvercle de protection en plastique sur le dessus des pieds à cinq branches (L003), insérez les cinq tiges de support du châssis (L002) dans les pieds à cinq branches à la position appropriée, et alignez les trous des tiges de support et des pieds à cinq branches.

NOTE : Veillez à ne pas vous pincer les doigts.

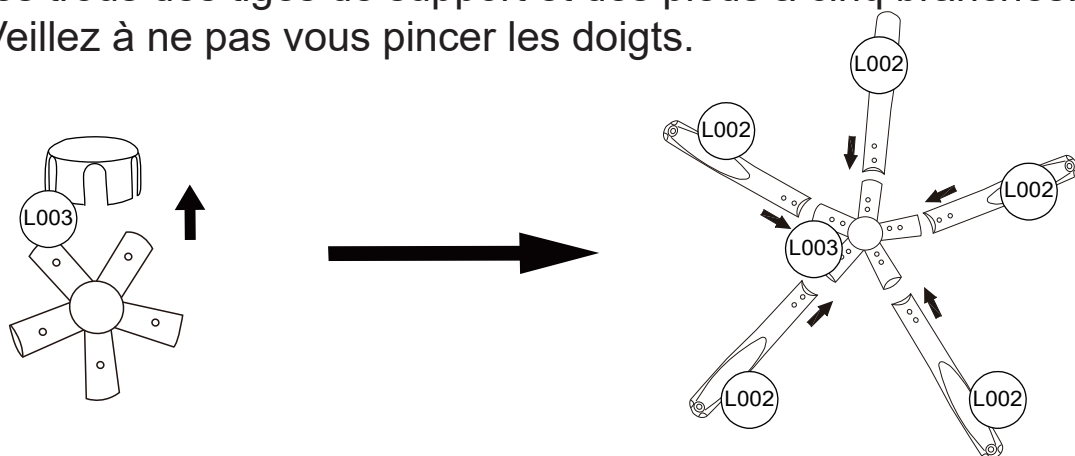

L002



x5

L003



x1

Étape 2 : Alignez les trous de vis et fixez-les avec les vis (K). Une fois l'installation sécurisée, fixez à nouveau le couvercle en plastique retiré à l'étape 1 sur la partie supérieure du pied à cinq branches (L003).

NOTE : Veillez à ne pas vous pincer les doigts et à bien serrer toutes les vis.

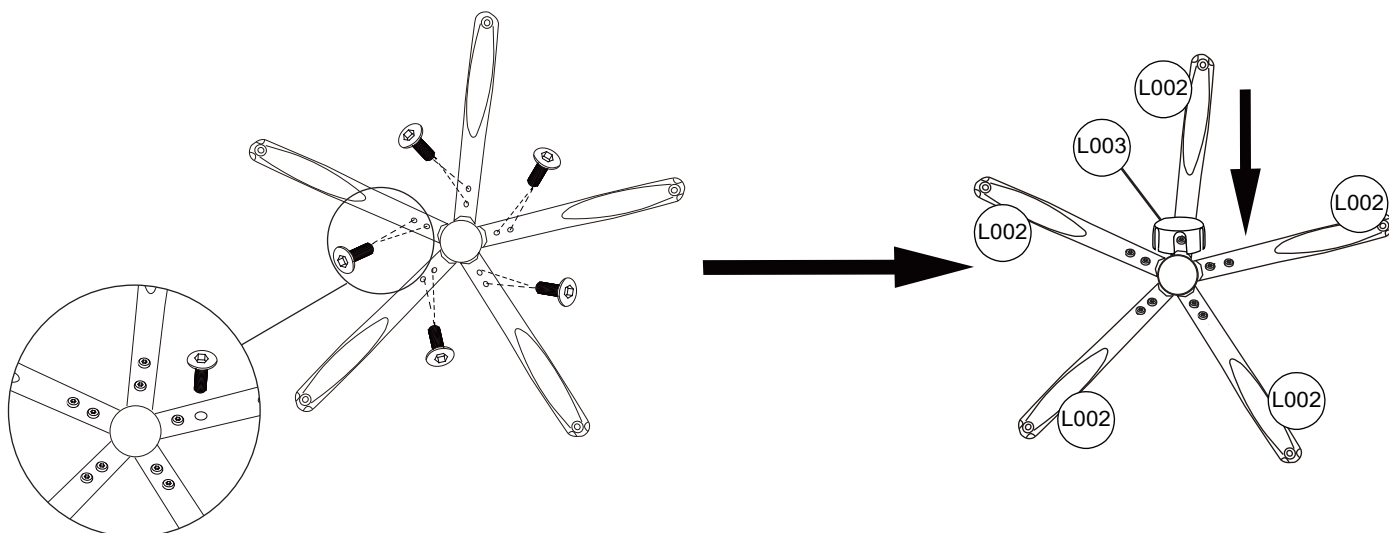

K



M6x16

x10

Étape 3 : En orientant le bas des pieds à cinq branches vers le haut, insérez fermement la roue du fauteuil (L001) dans le trou des pieds à cinq branches (L002).

NOTE: Veillez à ne pas vous pincer les doigts.

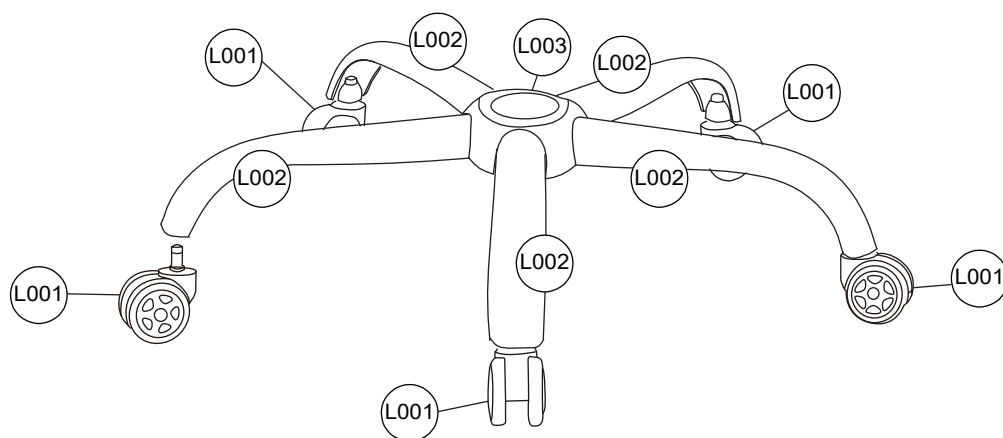

L001



x5

Étape 4 : Placez les pieds à cinq branches avec les roues de la chaise installées vers le bas, et insérez le bas de la tige de cylindre (L004) directement dans le trou des pieds à cinq branches (L002).

NOTE : Veillez à ne pas vous pincer les doigts.

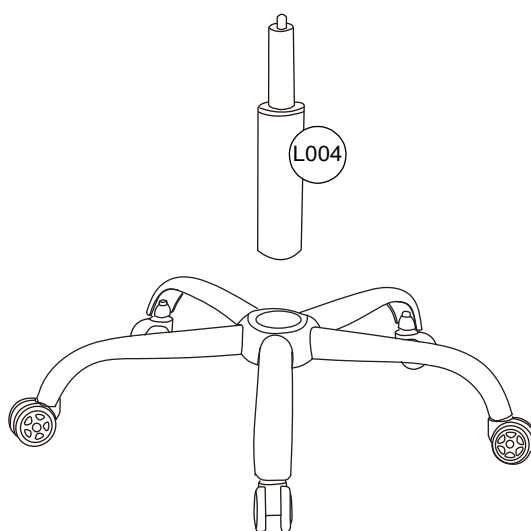

L004



x1

Étapes de l'installation

Étape 5 : Fixer la main courante (L007) à la barre de support de la main courante (L008) à l'aide des vis (K) comme indiqué sur le schéma.

NOTE : Veillez à ne pas vous pincer les doigts, à respecter le sens d'installation et à bien serrer toutes les vis.

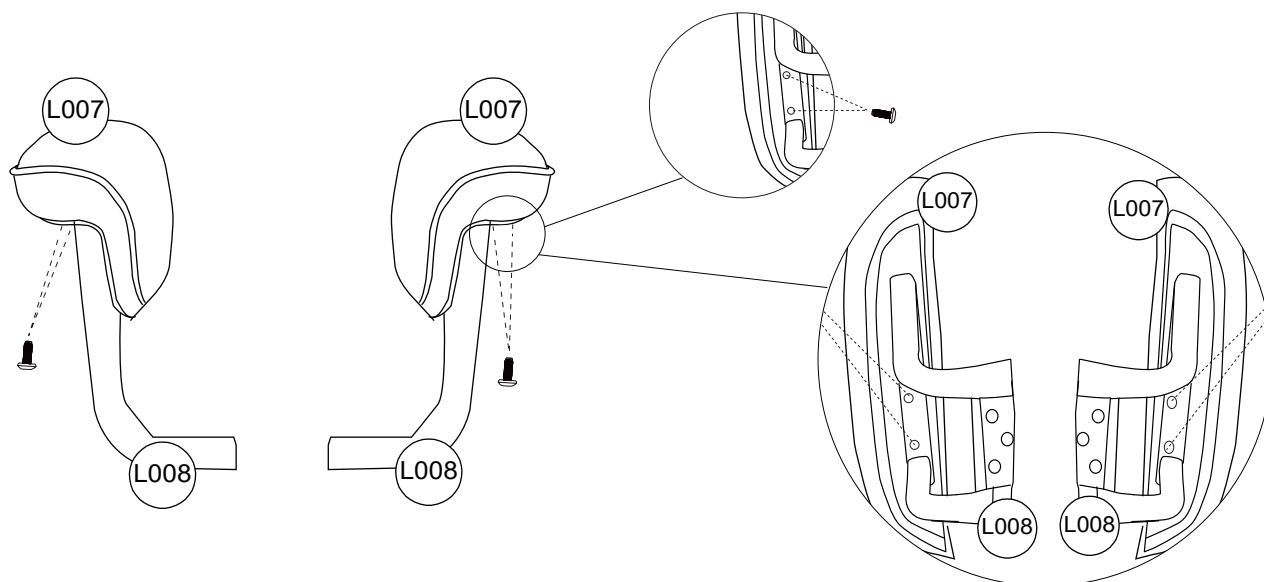

L007



x2

L008



x2

K



M6x16mm

x4

Étape 6 : Fixez chacun des deux accoudoirs installés à l'étape 5 avec des vis (N) aux emplacements correspondants sur la partie inférieure du coussin (L006).

NOTE : Veillez à ne pas vous pincer les doigts, à respecter le sens d'installation et à bien serrer toutes les vis.

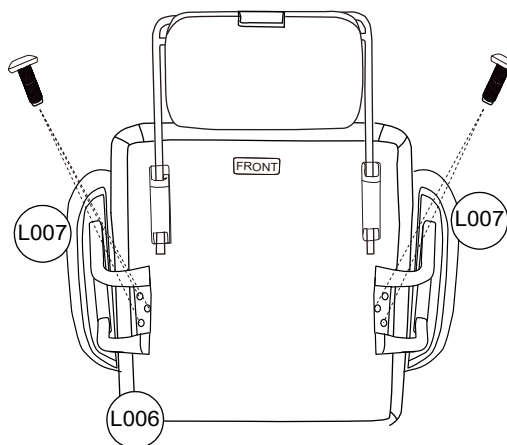

L006

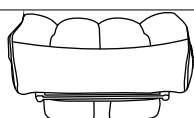

x1

N

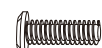

M6x20mm

x6

Étape 7 : Fixer le socle de réglage (L005) avec les vis (M) sous le coussin (L006) installé à l'étape 6, comme indiqué sur l'image.

NOTE : Achten Sie darauf, dass Sie die Installationsrichtung einhalten und alle Schrauben fest anziehen.

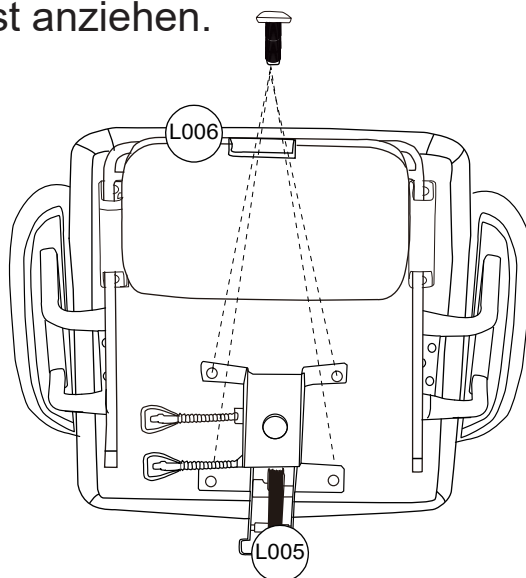

L005

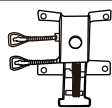

x1

M



M6x20mm

x4

Étape 8 : Insérer la partie du coussin assemblée à l'étape 7 sur la partie de la base assemblée à l'étape 4.

NOTE : Veillez à ne pas vous pincer les doigts.

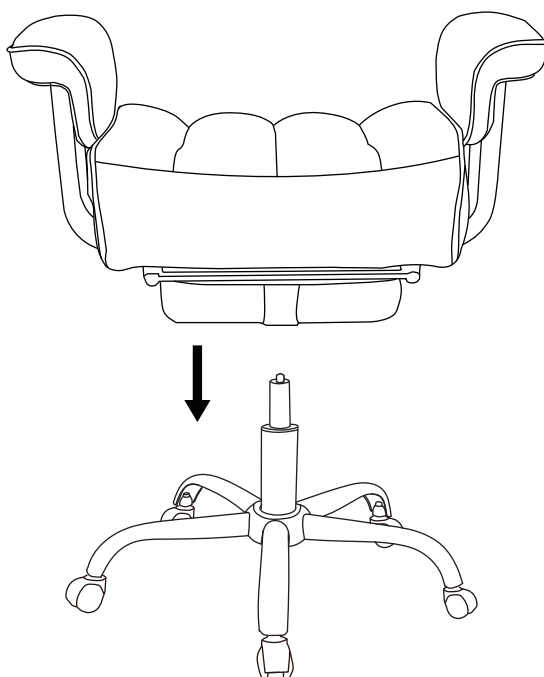

Étape 10 : Soulevez la plaque de recouvrement à l'arrière du dossier (L009) comme indiqué sur la figure et vissez la languette de connexion métallique (L010) à la position correspondante sur le dossier (L009).

NOTE : Please tighten all screws.

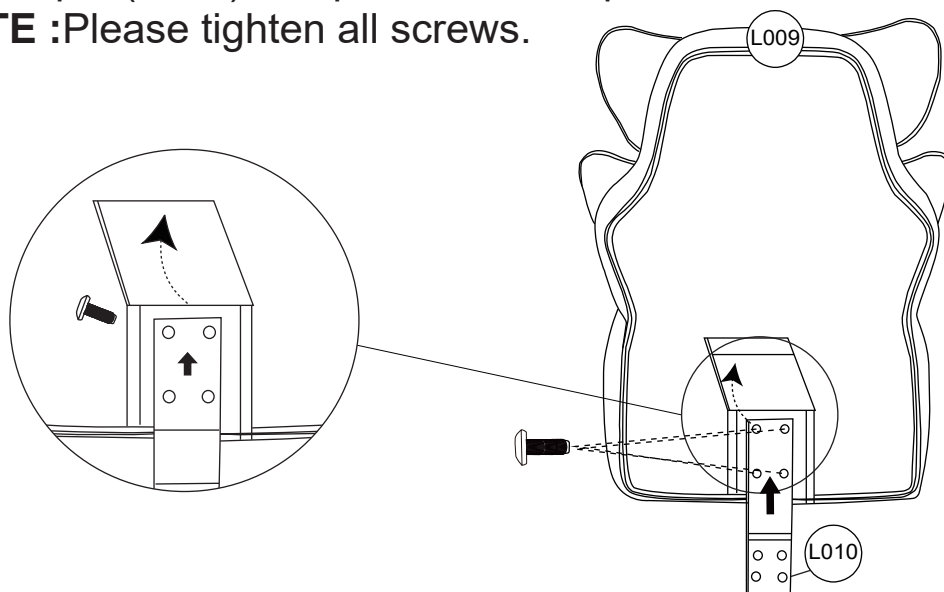

L010

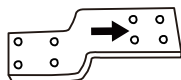

x1

L009

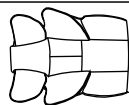

x1

L



M6x25mm

x4

Étape 11 : Comme indiqué sur la figure, fixer la partie du dossier assemblée à l'étape 5 avec la partie de la base assemblée à l'étape 4 à l'aide des vis (O) et de la languette de connexion métallique (L010).

NOTE : Veuillez serrer toutes les vis.

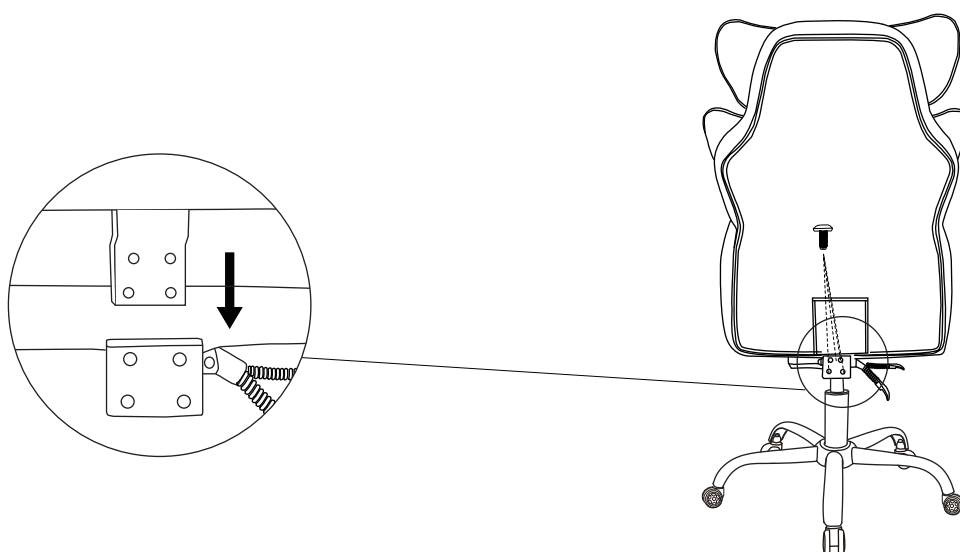

O

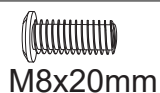

M8x20mm

x4

Étape 12 :Placez le coussin, l'installation est terminée.

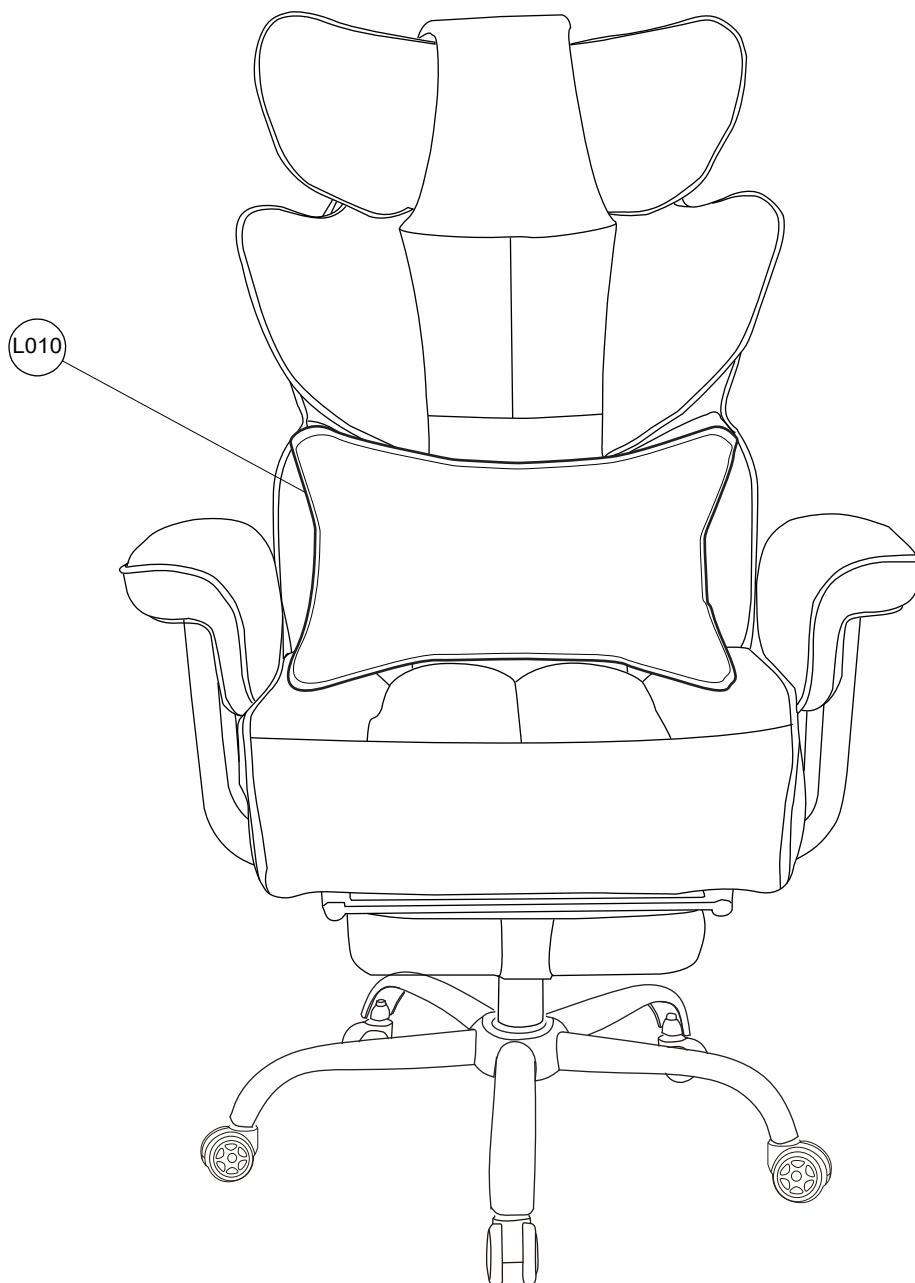

L011

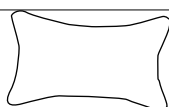

x1

Silla de oficina de cuero

Si tiene alguna pregunta sobre la silla de oficina de piel, no dude en ponerse en contacto con nosotros.

Correo electrónico del Servicio de Atención al Cliente: hgeurope@outlook.com

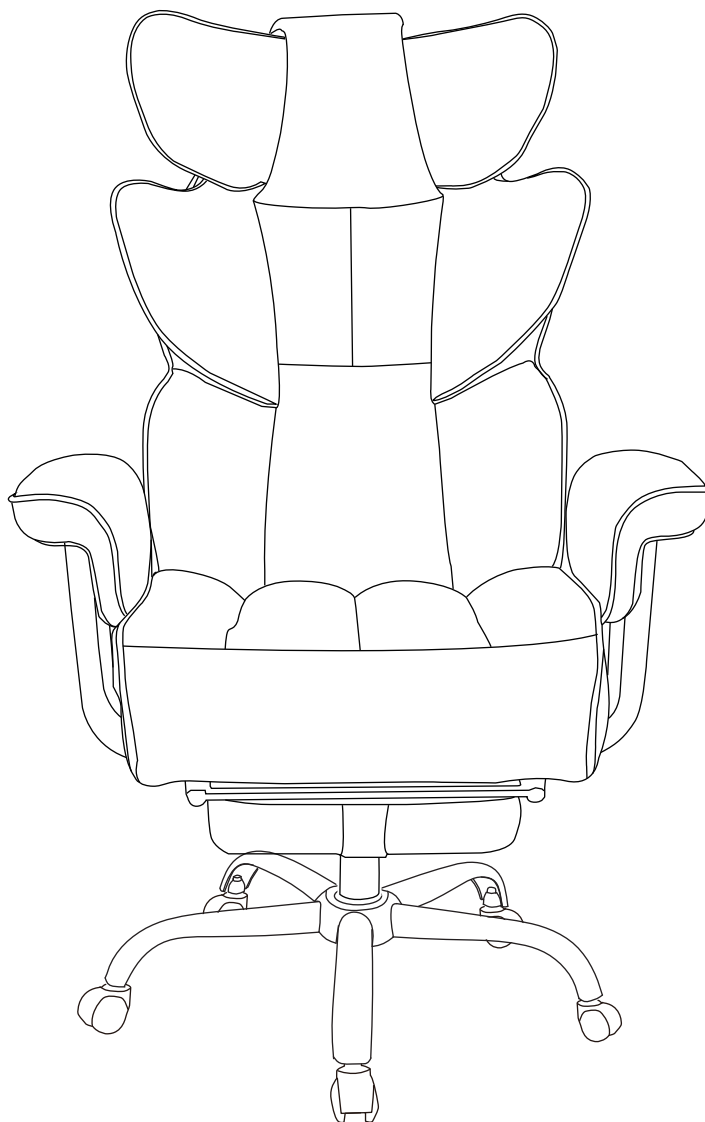

P25053D1

IMPORTANTE

LEER ANTES DE COMENZAR EL MONTAJE

Siga las directrices de esta guía del usuario para garantizar la correcta montaje y cuidado correctos de este producto.

ESPECIFICACIONES

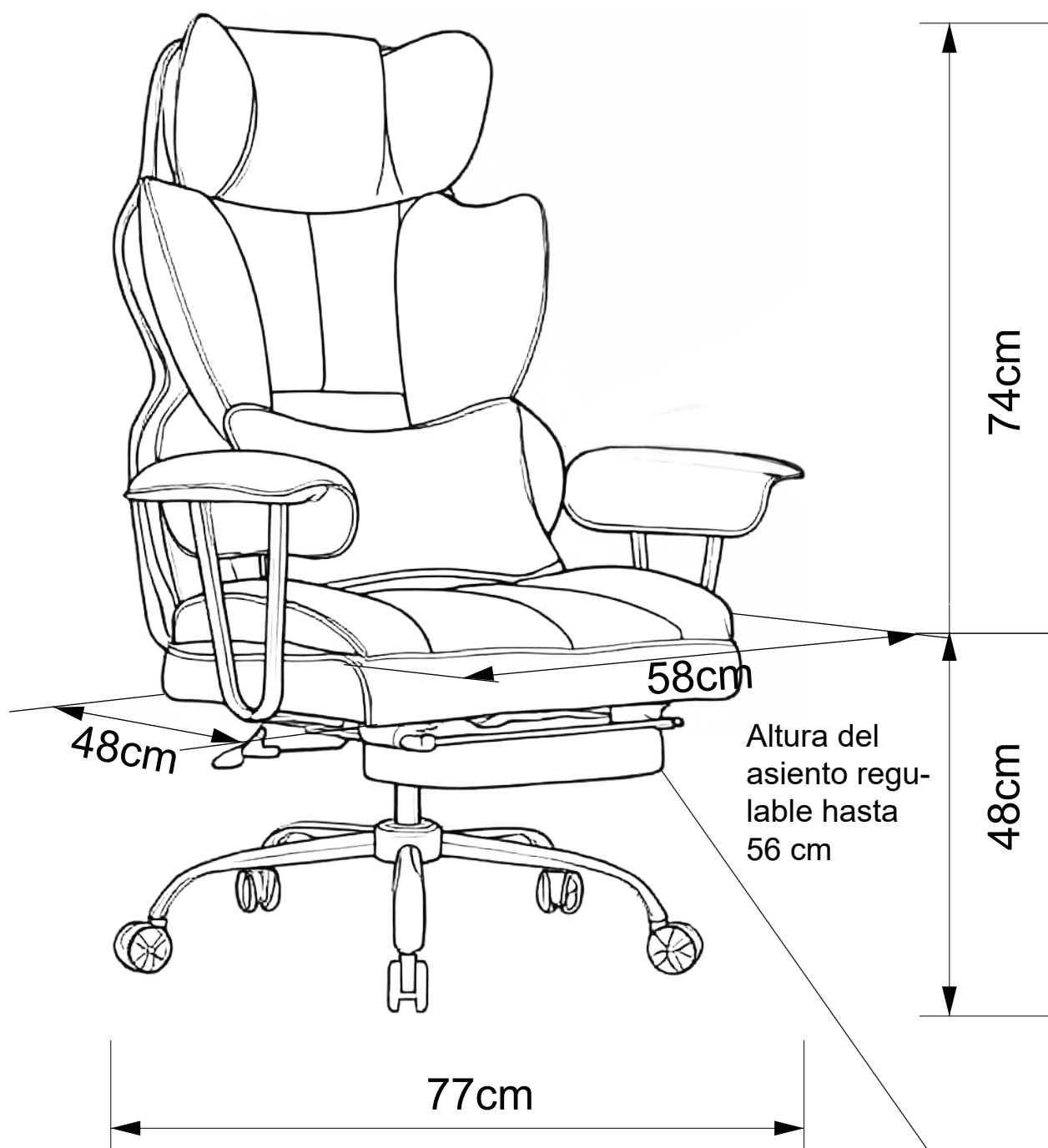

Extensión máxima de 89 cm desde la parte superior del reposapiés hasta la parte inferior del asiento

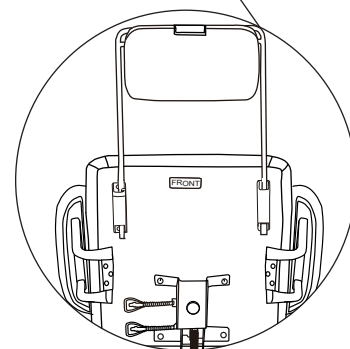

Catálogo

Especificaciones..... 01

Catálogo..... 02

Cuidados e instrucciones 03

Lista de piezas y lista de tornillos..... 04

Cómo utilizar la silla de oficina de cuero 06



Antes de empezar

Instrucciones de montaje:

Las instrucciones se suministran en este manual y contienen toda la información adecuada para su modelo de edificio.

Revise todas las instrucciones antes de comenzar y durante el montaje, siga cuidadosamente la secuencia de pasos para obtener resultados correctos.

Piezas y lista de piezas:

Compruebe que dispone de todas las piezas necesarias para la construcción.

Separe el contenido de la caja por el número de pieza mientras revisa la lista de piezas.

Familiarícese con los herrajes y elementos de fijación para facilitar su uso durante la construcción.

Los primeros pasos muestran cómo unir piezas relacionadas para obtener subconjuntos más grandes que se utilizarán más adelante.

Todas las piezas están embaladas dentro de la caja de cartón.



Tenga en cuenta que se han suministrado elementos de fijación adicionales para su comodidad.

Si tiene alguna pregunta sobre la silla de oficina de piel, no dude en ponerse en contacto con nosotros.

Correo electrónico del Servicio de Atención al Cliente: hgeurope@outlook.com



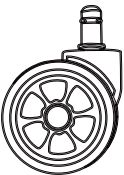
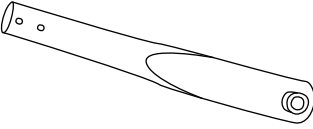
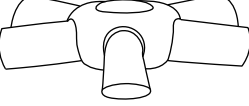

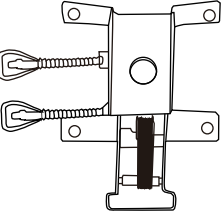
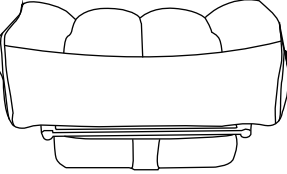
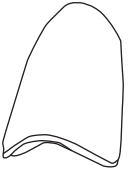
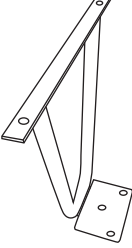
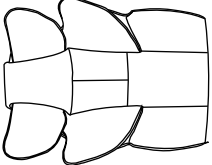
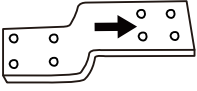
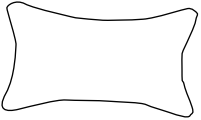



LISTA DE PIEZAS

Lista de piezas

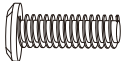
<p>L001</p>  <p>Volante de silla de carreras</p>	<p>L002</p>  <p>Varillas de soporte del chasis</p>	<p>L003</p>  <p>Pies de cinco estrellas</p>
<p>5 PCS</p>	<p>5 PCS</p>	<p>1 PC</p>
<p>L004</p>  <p>Vástago de cilindro</p>	<p>L005</p>  <p>Base de ajuste</p>	<p>L006</p>  <p>Cojín</p>
<p>1 PC</p>	<p>1 PC</p>	<p>1 PC</p>
<p>L007</p>  <p>Planos de pasamanos</p>	<p>L008</p>  <p>Barras de soporte de pasamanos</p>	<p>L009</p>  <p>Respaldo</p>
<p>2 PCS</p>	<p>2 PCS</p>	<p>1 PC</p>
<p>L010</p>  <p>Lengüeta de conexión metálica</p>	<p>L011</p>  <p>Almohada lumbar</p>	
<p>1 PC</p>	<p>1 PC</p>	

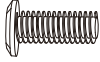
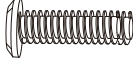
LISTA DE PIEZAS

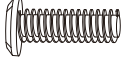
Lista de tornillos

<p>(K)</p>  <p>M6x16</p>	<p>(L)</p>  <p>M6x25</p>	<p>(M)</p>  <p>M6x20</p>
<p>14 PCS</p>	<p>4 PCS</p>	<p>4 PCS</p>
<p>(N)</p>  <p>M6x20</p>	<p>(O)</p>  <p>M8x20</p>	<p>(P)</p> 
<p>6 PCS</p>	<p>4 PCS</p>	<p>1 PC</p>
<p>Extra (Juego de tornillos)</p>		
<p>(K)</p>  <p>M6x16</p>	<p>(L)</p>  <p>M6x25</p>	<p>(M)</p>  <p>M6x20</p>
<p>1 PC</p>	<p>1 PC</p>	<p>1 PC</p>
<p>(N)</p>  <p>M6x20</p>	<p>(O)</p>  <p>M8x20</p>	<p>(P)</p> 
<p>1 PC</p>	<p>1 PC</p>	<p>1 PC</p>

Cómo montar la silla de oficina de cuero

Paso 1: Retire la cubierta protectora de plástico de la parte superior de las patas de cinco radios (L003), inserte las cinco varillas de soporte del chasis (L002) en las patas de cinco radios hasta la posición adecuada y alinee los orificios de las varillas de soporte y las patas de cinco radios.

NOTA: Tenga cuidado de no pillarse los dedos.

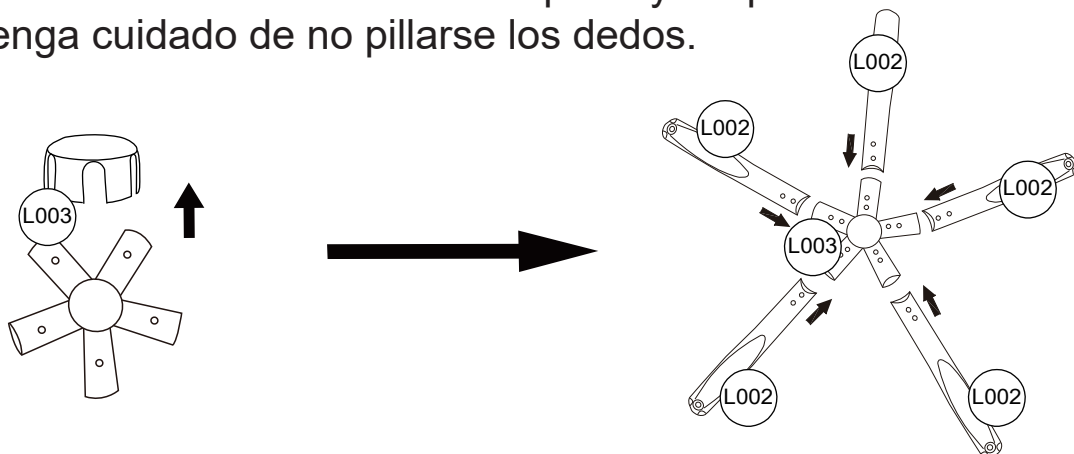

L002



x5

L003



x1

Paso 2: Alinee los orificios de los tornillos y fíjelos con tornillos (K). Una vez instalado firmemente, vuelva a colocar la cubierta de plástico retirada en el paso 1 en la parte superior del pie de cinco estrellas (L003).

NOTA: Tenga cuidado de no pillarse los dedos y apriete todos los tornillos.

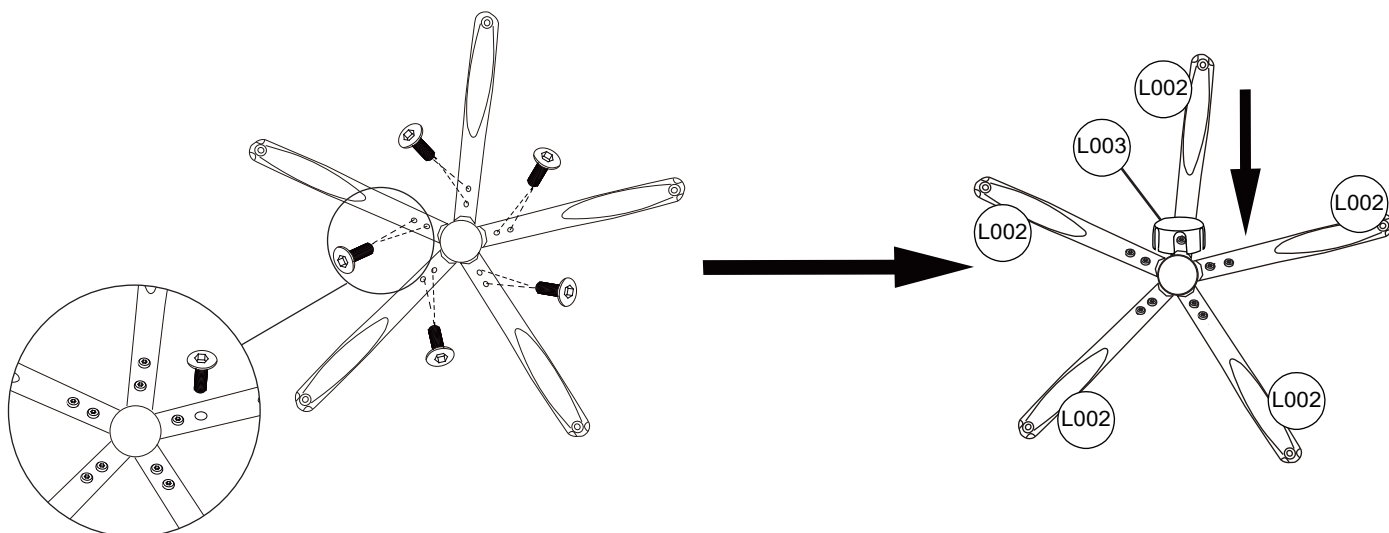

K



M6x16

x10

Paso 3: Con la parte inferior de las patas de cinco radios hacia arriba, inserte firmemente la rueda de la silla (L001) en el orificio de las patas de cinco radios (L002).

NOTA: Tenga cuidado de no pillarse los dedos.

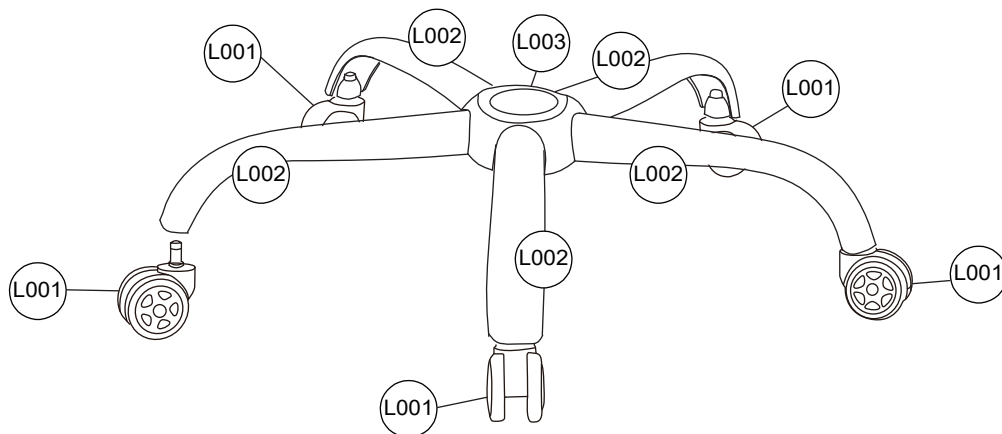

L001



x5

Paso 4: Coloque las patas de cinco radios con las ruedas de la silla instaladas hacia abajo e inserte la parte inferior de la varilla cilíndrica (L004) directamente en el orificio de las patas de cinco radios (L002).

NOTA: Tenga cuidado de no pillarse los dedos.

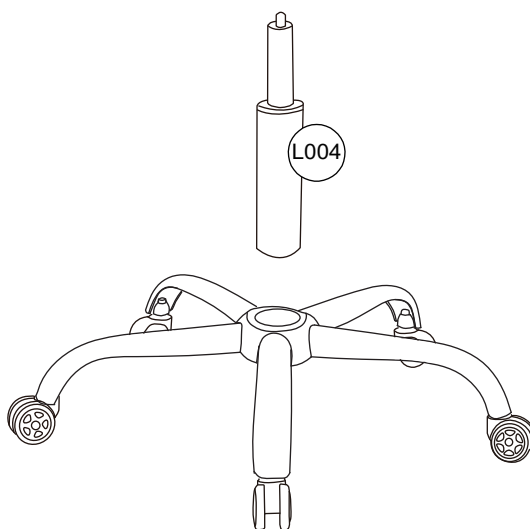

L004



x1

Paso 5: Fije el pasamanos (L007) a la barra de soporte del pasamanos (L008) con tornillos (K) como se muestra en el diagrama.

NOTA: Preste atención a la dirección de instalación y apriete todos los tornillos.

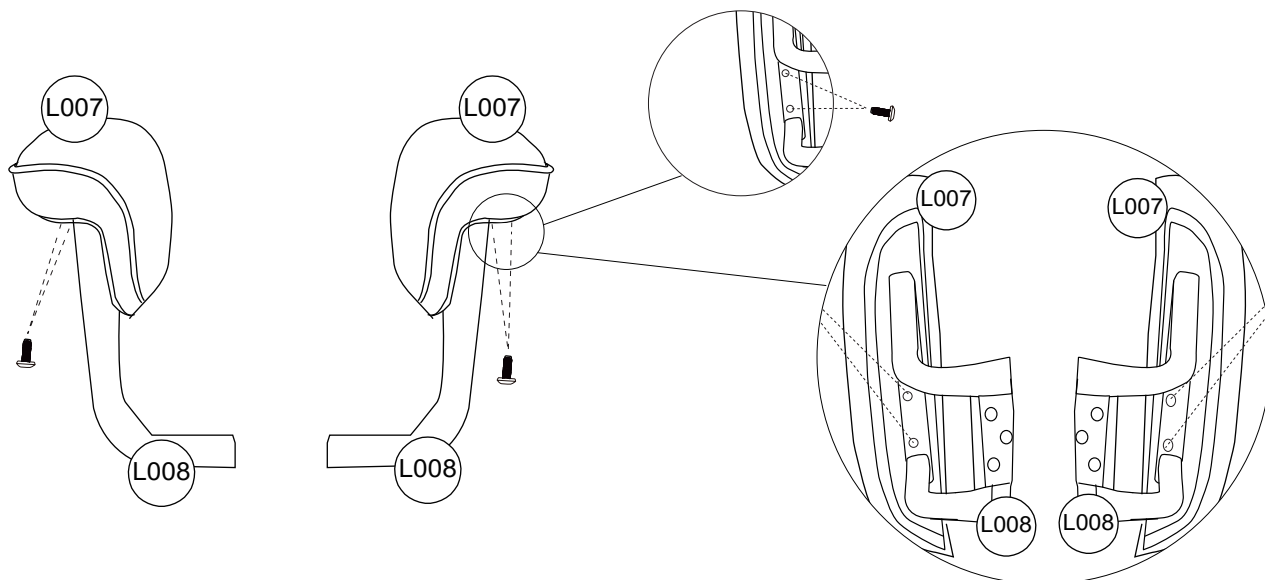

L007



x2

L008



x2

K



M6x16mm

x4

Paso 6: Fije cada uno de los dos reposabrazos instalados en el paso 5 con tornillos (N) en los lugares correspondientes de la parte inferior del cojín (L006).

NOTA: Preste atención a la dirección de instalación y apriete todos los tornillos.

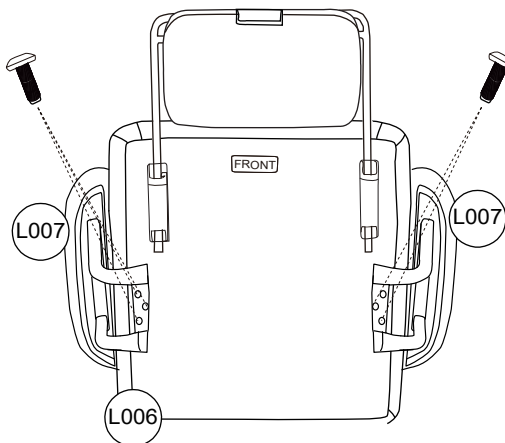

L006

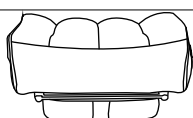

x1

N



M6x20mm

x6

Paso 7: Fije la cubeta de ajuste (L005) con tornillos (M) debajo del cojín (L006) instalado en el paso 6 como se muestra en la imagen.

NOTA: Preste atención a la dirección de instalación y apriete todos los tornillos.

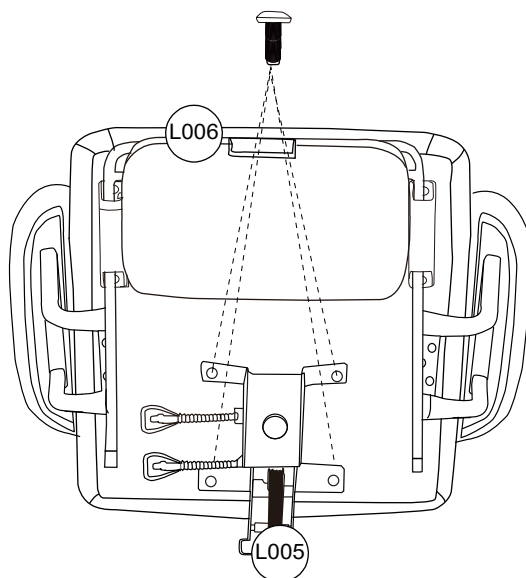

L005

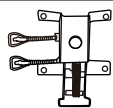

x1

M



M6x20mm

x4

Paso 8: Inserte la parte del cojín ensamblada en el paso 7 encima de la parte de la base ensamblada en el paso 4.

NOTA: Tenga cuidado de no pillarse los dedos.

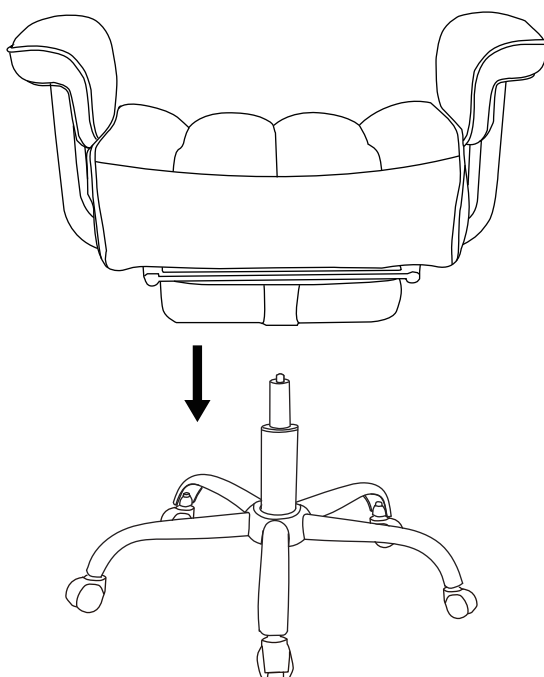

Paso 10: Levante la placa de cubierta de la parte posterior del respaldo (L009) como se muestra en la figura y atornille la lengüeta de conexión metálica (L010) en la posición correspondiente del respaldo (L009).

NOTA: Apriete todos los tornillos.

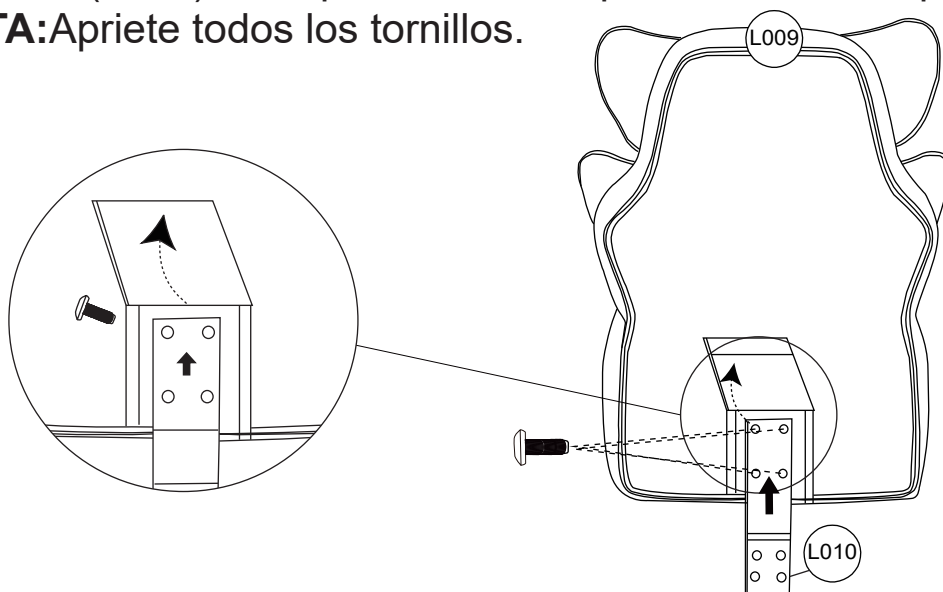

L010

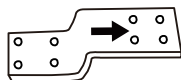

x1

L009

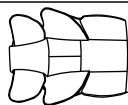

x1

L



M6x25mm

x4

Paso 11: Como se muestra en la figura, fije la parte del respaldo ensamblada en el paso 5 con la parte de la base ensamblada en el paso 4 mediante tornillos (O) y lengüeta metálica de conexión (L010).

NOTA: Apriete todos los tornillos.

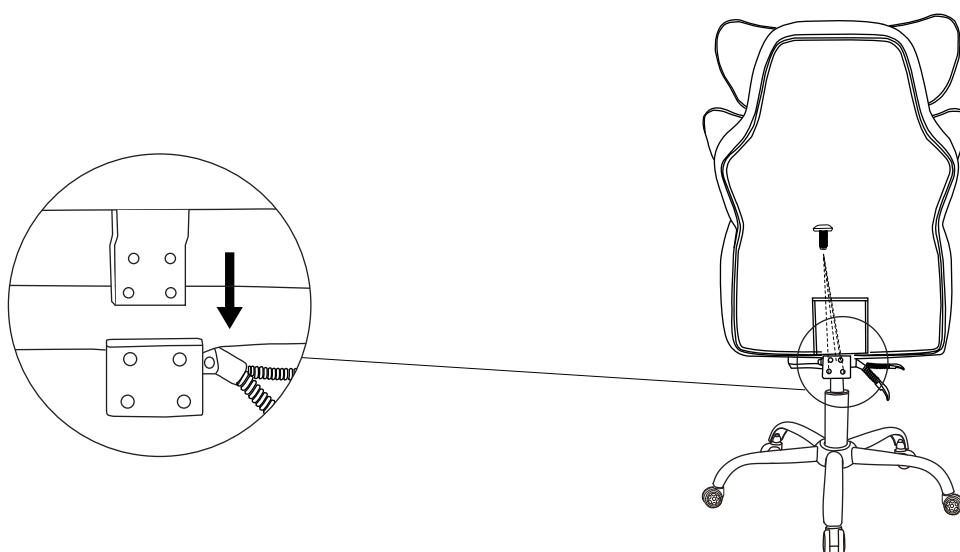

O



M8x20mm

x4

Paso 12: Coloque el cojín, la instalación está completa.

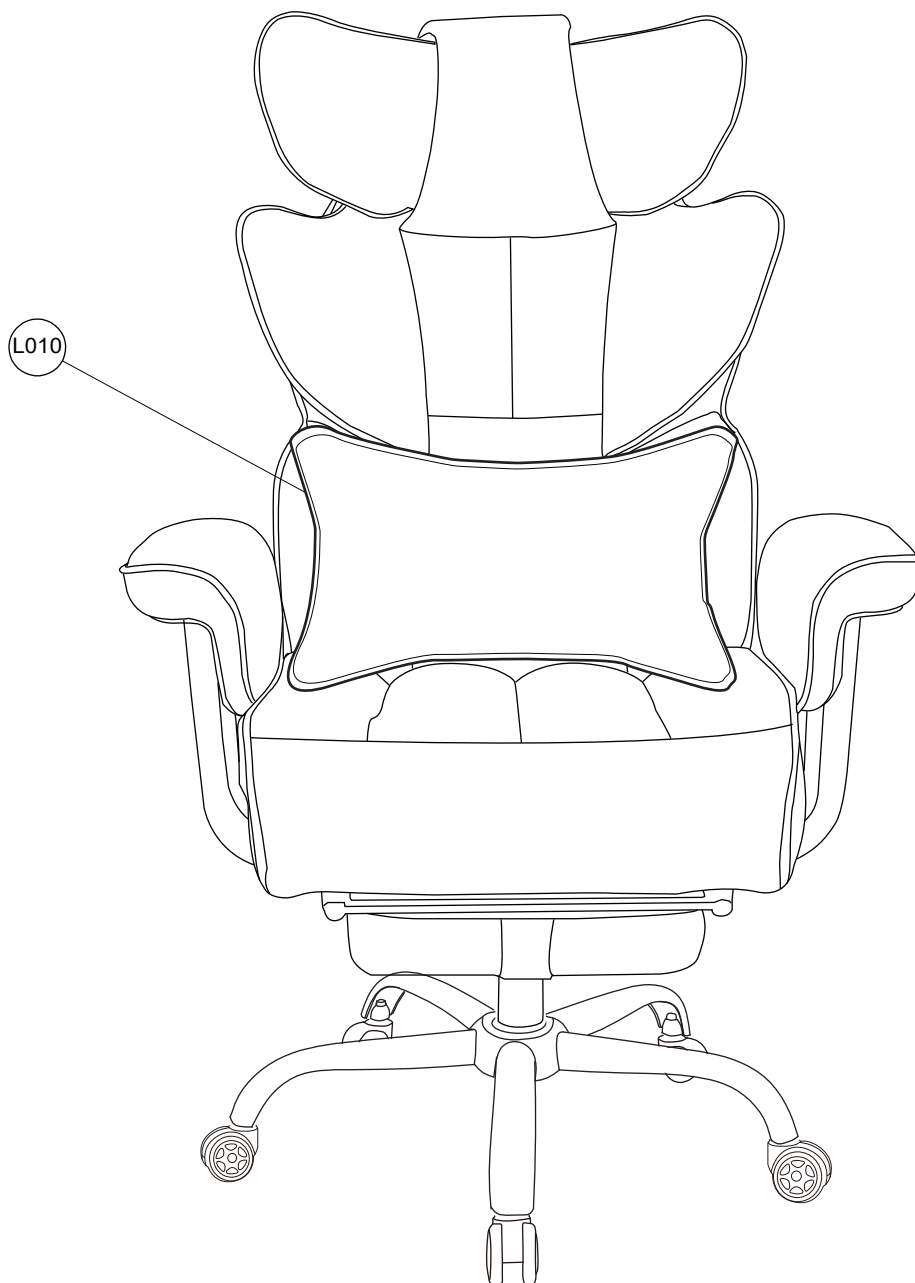

L011

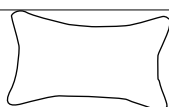

x1

Sedia da ufficio in pelle

Se avete domande sulla sedia da ufficio in pelle, non esitate a contattarci.

Email del servizio clienti: hgeurope@outlook.com

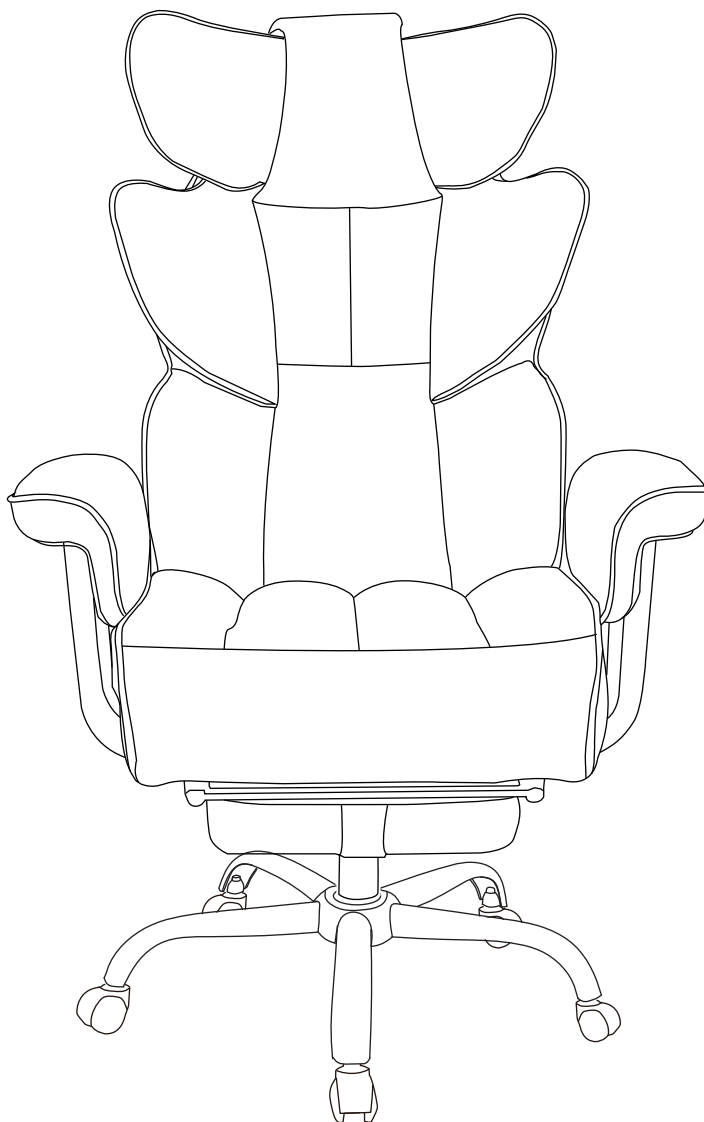

P25053D1

IMPORTANTE

LEGGERE PRIMA DI INIZIARE IL MONTAGGIO

Seguire le linee guida di questo manuale d'uso per garantire la correttezza delle operazioni.
montaggio e la cura del prodotto.

SPECIFICHE

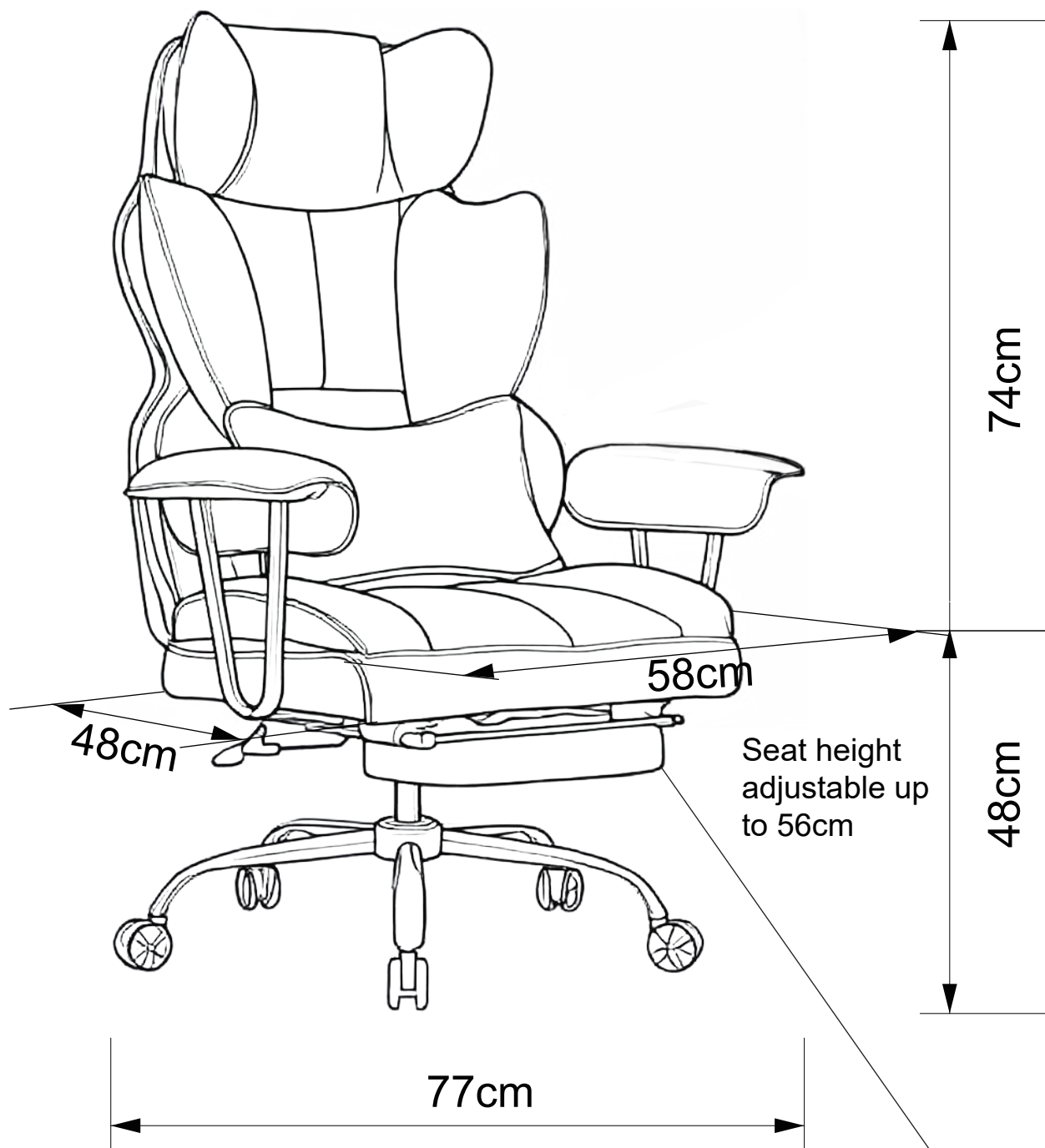

Estensione massima di 89 cm dalla parte superiore del poggiatesta alla parte inferiore del sedile quando il poggiatesta è estratto.

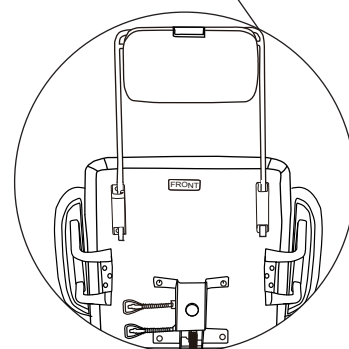

Catalog

Specifiche tecniche.....	01
Catalog.....	02
Cura e istruzioni	03
Elenco parti e set di viti.....	04
Come utilizzare la sedia da ufficio in pelle	06

Prima di iniziare

Istruzioni per il montaggio:

Le istruzioni sono fornite in questo manuale e contengono tutte le informazioni appropriate per il modello di edificio in uso.

Leggere tutte le istruzioni prima di iniziare e durante il montaggio, seguire attentamente la sequenza dei passaggi per ottenere risultati corretti.

Parti ed elenco parti:

Verificare che siano presenti tutti i componenti necessari per la costruzione.

Separare il contenuto della scatola in base al numero di parte mentre si esamina l'elenco delle parti.

Familiarizzare con la ferramenta e gli elementi di fissaggio per facilitarne l'uso durante la costruzione.

I primi passi mostrano come unire parti correlate per ottenere sottoinsiemi più grandi da utilizzare in seguito.





Tutte le parti sono confezionate all'interno del cartone.

Per comodità, sono stati forniti altri elementi di fissaggio.

Se avete domande sulla sedia da ufficio in pelle, non esitate a contattarci.

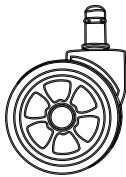
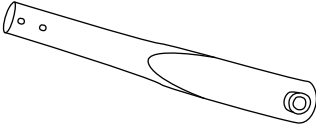
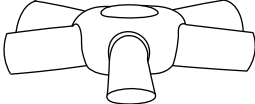

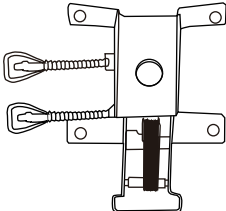
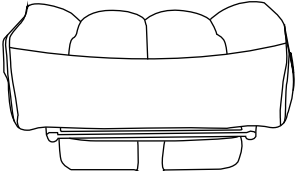

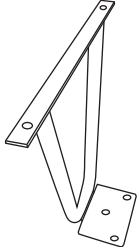
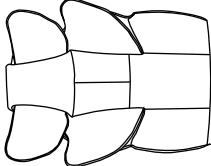
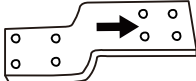
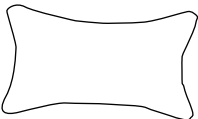



Email del servizio clienti: hgeurope@outlook.com

ELENCO PARTI

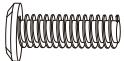
Elenco delle parti		
<p>L001</p>  <p>Sedia da corsa a rotelle</p>	<p>L002</p>  <p>Aste di supporto del telaio</p>	<p>L003</p>  <p>Piedi a cinque stelle</p>
5 PCS	5 PCS	1 PC
<p>L004</p>  <p>Asta del cilindro</p>	<p>L005</p>  <p>Base di regolazione</p>	<p>L006</p>  <p>Cuscino</p>
1 PC	1 PC	1 PC
<p>L007</p>  <p>Piani per corrimano</p>	<p>L008</p>  <p>Barre di supporto del corrimano</p>	<p>L009</p>  <p>Schienale</p>
2 PCS	2 PCS	1 PC
<p>L010</p>  <p>Linguetta di connessione in metallo</p>	<p>L011</p>  <p>Cuscino lombare</p>	
1 PC	1 PC	

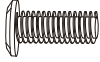
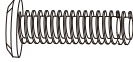
ELENCO PARTI

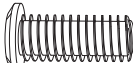
Elenco dei set di viti

<p>(K)</p>  <p>M6x16</p>	<p>(L)</p>  <p>M6x25</p>	<p>(M)</p>  <p>M6x20</p>
<p>14 PCS</p>	<p>4 PCS</p>	<p>4 PCS</p>
<p>(N)</p>  <p>M6x20</p>	<p>(O)</p>  <p>M8x20</p>	<p>(P)</p> 
<p>6 PCS</p>	<p>4 PCS</p>	<p>1 PC</p>
<p>Extra (set di viti)</p>		
<p>(K)</p>  <p>M6x16</p>	<p>(L)</p>  <p>M6x25</p>	<p>(M)</p>  <p>M6x20</p>
<p>1 PC</p>	<p>1 PC</p>	<p>1 PC</p>
<p>(N)</p>  <p>M6x20</p>	<p>(O)</p>  <p>M8x20</p>	<p>(P)</p> 
<p>1 PC</p>	<p>1 PC</p>	<p>1 PC</p>

Come assemblare la sedia da ufficio in pelle

Passaggio 1: Rimuovere la copertura protettiva in plastica sulla parte superiore dei piedini a cinque stelle (L003), inserire le cinque aste di supporto del telaio (L002) nei piedini a cinque stelle nella posizione appropriata e allineare i fori delle aste di supporto e dei piedini a cinque stelle.

NOTA: Fate attenzione a non schiacciarsi le dita.

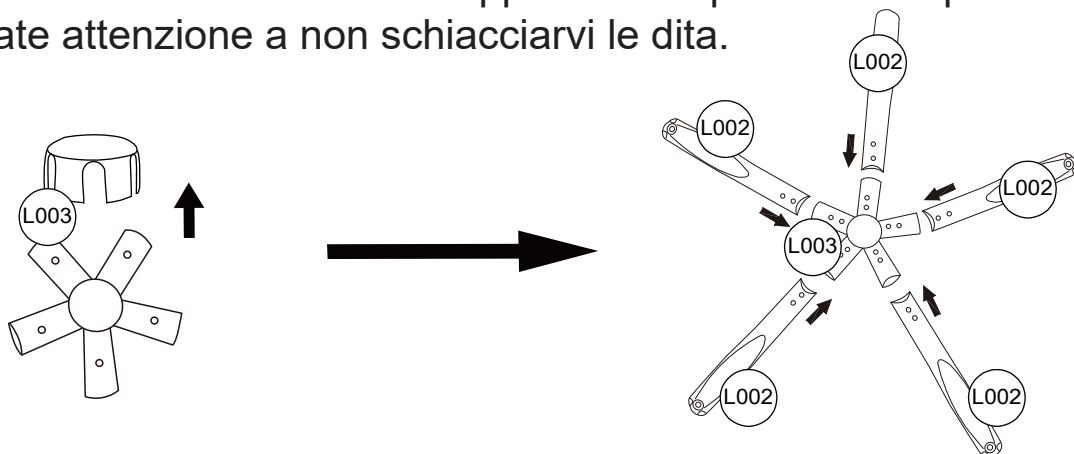

L002



x5

L003

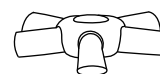

x1

Passaggio 2: Allineare i fori delle viti e fissarli con le viti (K). Una volta installato saldamente, rimontare il coperchio di plastica rimosso al punto 1 sulla parte superiore del piede a cinque stelle (L003).

NOTA: Be careful not to pinch your fingers and please tighten all screws.

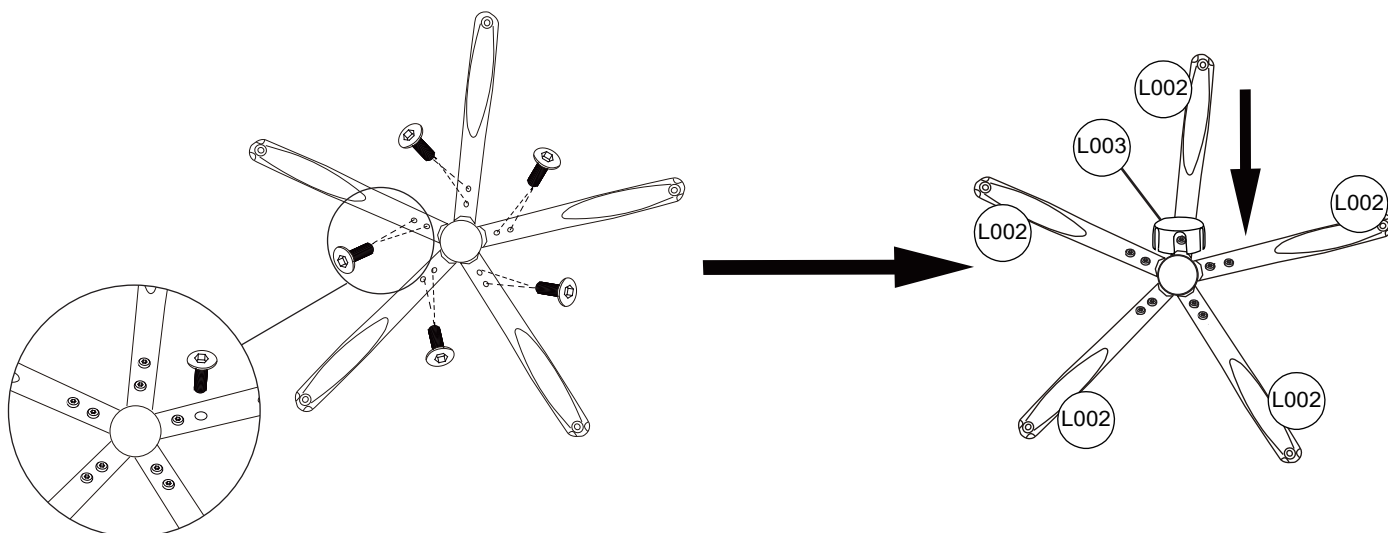

K



M6x16

x10

Passaggio 3: Con la parte inferiore dei piedini a cinque stelle rivolta verso l'alto, inserire saldamente la ruota della sedia (L001) nel foro dei piedini a cinque stelle (L002).

NOTA: Fate attenzione a non schiacciarvi le dita.

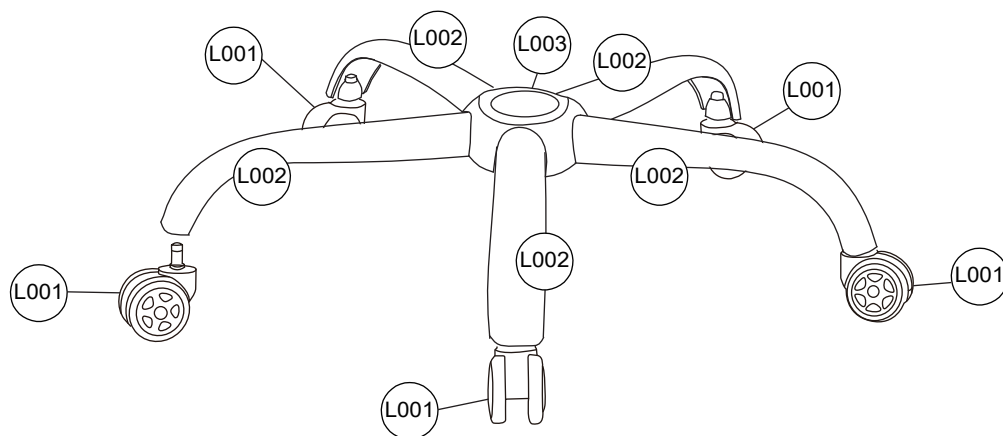

L001



x5

Passaggio 4: Posizionare i piedini a cinque stelle con le ruote della sedia installate verso il basso e inserire la parte inferiore dell'asta del cilindro (L004) direttamente nel foro dei piedini a cinque stelle (L002).

NOTA: Fate attenzione a non schiacciarvi le dita.

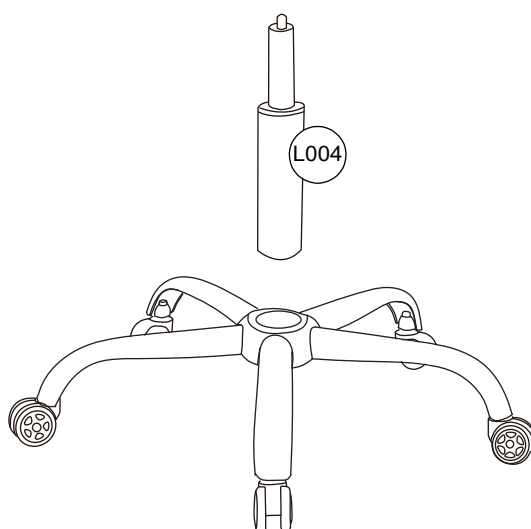

L004



x1

Passaggio 5: Fissare il corrimano (L007) alla barra di supporto del corrimano (L008) con le viti (K) come indicato nella figura.

NOTA: Fare attenzione a non schiacciarsi le dita. Prestare attenzione alla direzione di installazione e serrare tutte le viti.

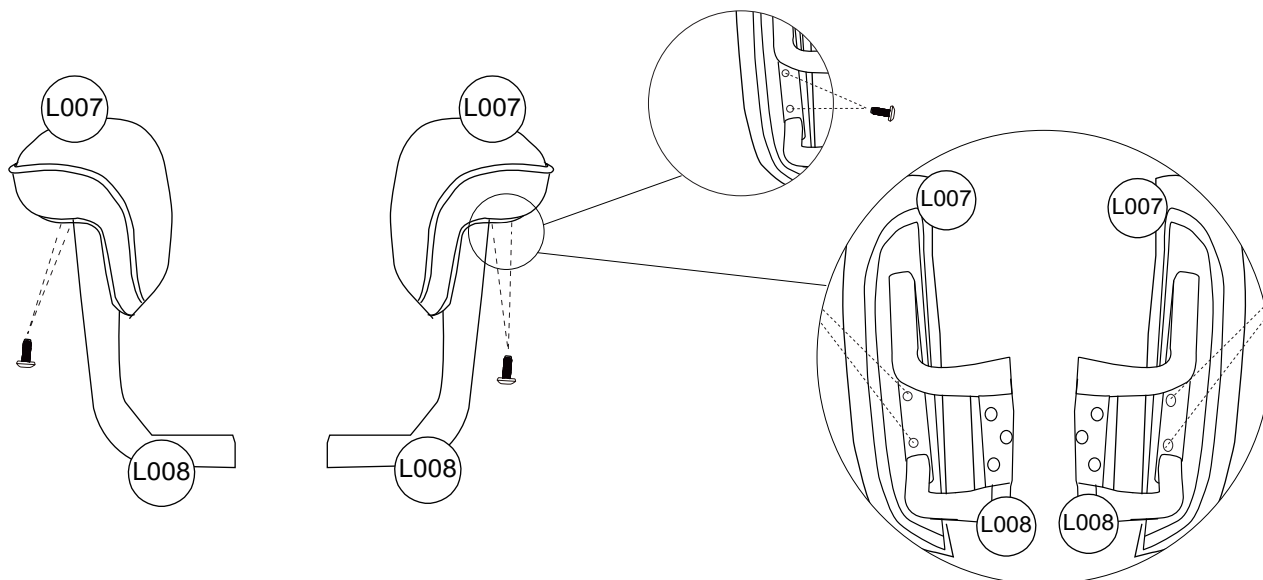

L007



x2

L008



x2

K



M6x16mm

x4

Passaggio 6: Fissare ciascuno dei due braccioli installati al punto 5 con le viti (N) nei punti corrispondenti della parte inferiore del cuscino (L006).

NOTA: Fare attenzione a non schiacciarsi le dita. Prestare attenzione alla direzione di installazione e serrare tutte le viti.

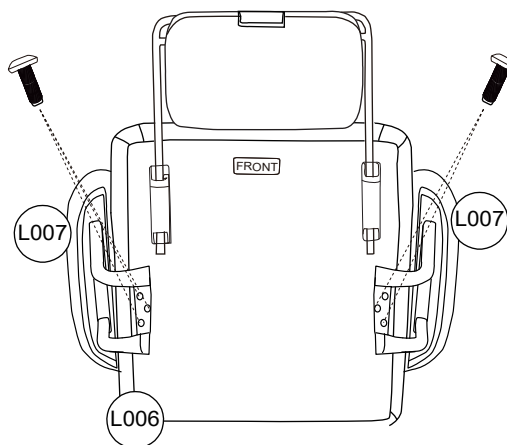

L006

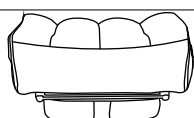

x1

N

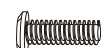

M6x20mm

x6

Passaggio 7: Fissare il pozzetto di regolazione (L005) con le viti (M) sotto il cuscino (L006) installato al punto 6, come mostrato nella figura.

NOTA: Prestare attenzione alla direzione di installazione e serrare tutte le viti.

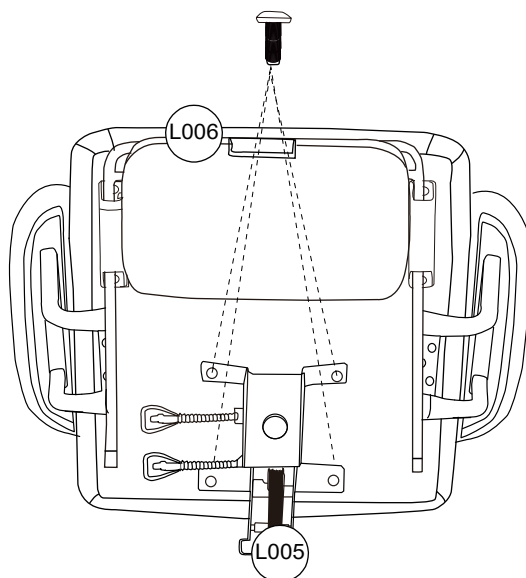

L005

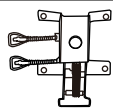

x1

M



M6x20mm

x4

Passaggio 8: Inserire la parte del cuscino assemblata al punto 7 sopra la parte della base assemblata al punto 4.

NOTA: Fate attenzione a non schiacciarsi le dita.

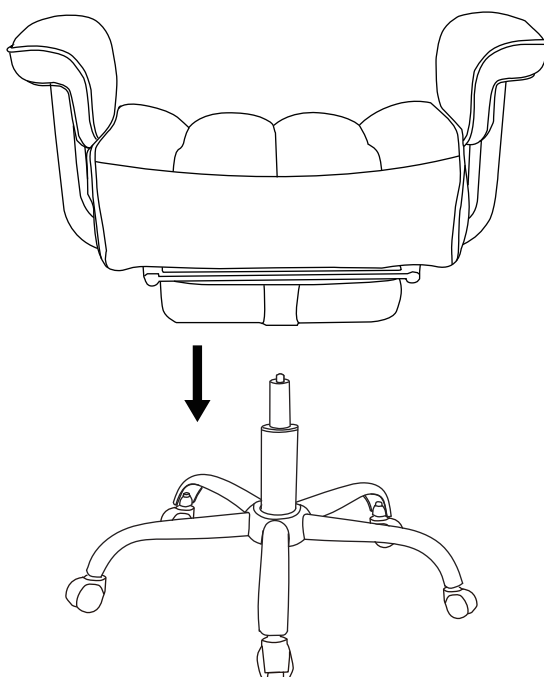

Passaggio 10: Sollevare la piastra di copertura sul retro dello schienale (L009) verso l'alto come mostrato in figura e avvitare la linguetta di collegamento metallica (L010) nella posizione corrispondente sullo schienale (L009).

NOTA: Serrare tutte le viti.

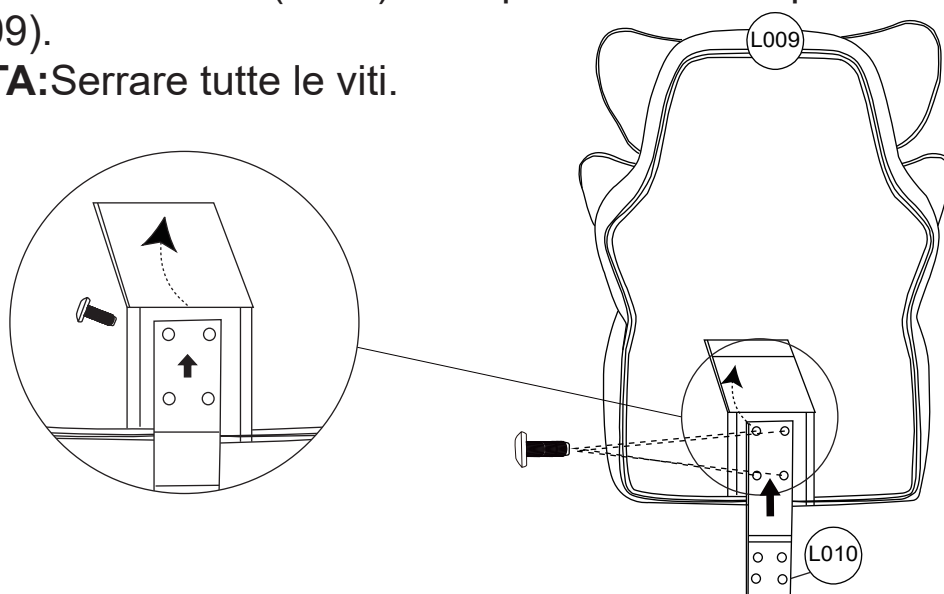

L010

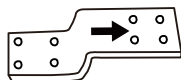

x1

L009

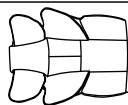

x1

L



M6x25mm

x4

Passaggio 11: Come mostrato in figura, fissare la parte dello schienale assemblata al punto 5 con la parte della base assemblata al punto 4 mediante le viti (O) e la linguetta di collegamento in metallo (L010).

NOTA: Serrare tutte le viti.

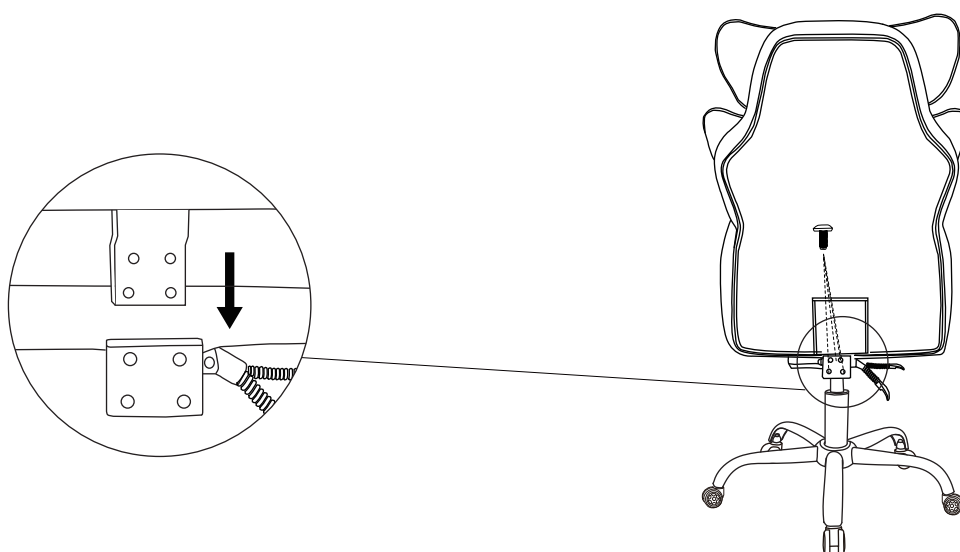

O

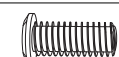

M8x20mm

x4

Passaggio 12: Mettere il cuscino, l'installazione è completa

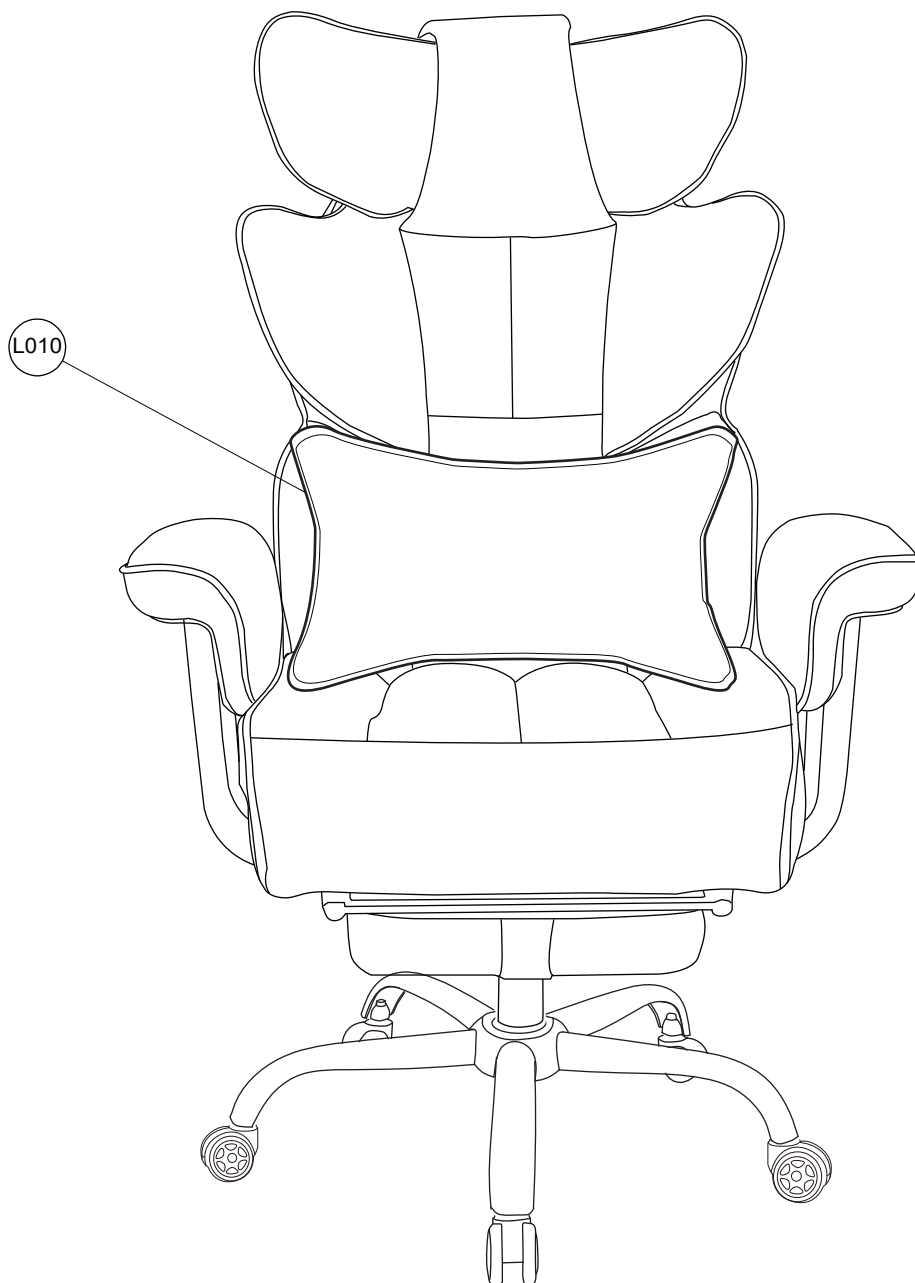

L011

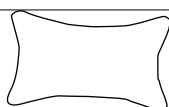

x1