

ASSEMBLY INSTRUCTIONS TON BENCH

ASSEMBLY
REQUIREMENTS

2-Person
Assembly

30 Minutes
Assembly Time Per Chair
(Approximate)

Thank you for purchasing our product!

Please refer and use this assembly instruction to assemble the product. Contact our customer service department in case there are any missing or damaged parts or hardware. Replacement parts are normally shipped within 2 or 3 days.



PRODUCTS PURCHASED THROUGH OUR AUTHORIZED VENDORS ONLY ARE ELIGIBLE FOR REPLACEMENT PARTS

We appreciate your business!

**THIS PRODUCT IS FOR INDOOR AND HOUSEHOLD USE ONLY -
NOT FOR COMMERCIAL USE.**

ASSEMBLY PREPARATION

1. Remove all packaging materials, staples and packing straps from the carton.
2. Refer to Parts List and Hardware List, and ensure parts and hardware are correct before assembly.
Contact customer service for missing parts.
3. Place all wooden parts on a clean, flat and soft surface (e.g. carpet or rug) to prevent scratch and damage to parts.

SAFETY PRECAUTION

1. KEEP ALL HARDWARE PARTS OUT OF REACH OF CHILDREN.
2. DISPOSE PLASTIC PACKAGING MATERIAL IMMEDIATELY TO AVOID ANY RISK OF SUFFOCATION TO CHILDREN AND ANIMALS.

TIPS FOR ASSEMBLY

1. Allow ample room for assembly and in close proximity to where product will be placed.
2. Assemble the product on a surface that does not scratch or damage the exterior gloss and finish of the furniture.
3. Identify all of the parts, hardware and quantities required for each step.
4. During assembly, do not over-tighten any fittings as this may cause damage.
5. DO NOT USE POWER TOOLS TO ASSEMBLE THIS PRODUCT.
6. Always place the product on a flat, level surface.
7. Do not sit or stand on the partially assembled product; only use the product for which it is intended.

CARE AND MAINTENANCE



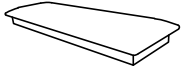
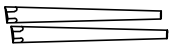

- Wipe clean with a soft, dry cloth; avoid the use of harsh chemicals or household cleaners as they may damage the exterior finish of the furniture.
- Hardware may loosen over time. Periodically, check that all connections are tight; re-tighten as necessary.
- Solid wood is impacted by heat and humidity fluctuations which may cause small joint separations or hairline cracks; place the furniture away from direct sunlight and air conditioning vents, heating vents or units to protect the furniture.

ASSEMBLY INSTRUCTIONS BENCH

PARTS LIST

ITEM	PART NAME	QTY
1	BENCH TOP 	1
2	LEG 	4

HARDWARE LIST

ITEM	HARDWARE NAME	DESCRIPTION	QTY	EXTRA
A	JCBC BOLT M6 x 60MM		8	1
B	FLAT WASHER		8	1
C	SPRING WASHER		8	1
D	ALLEN KEY M4		1	-

**Extra hardware for spare use

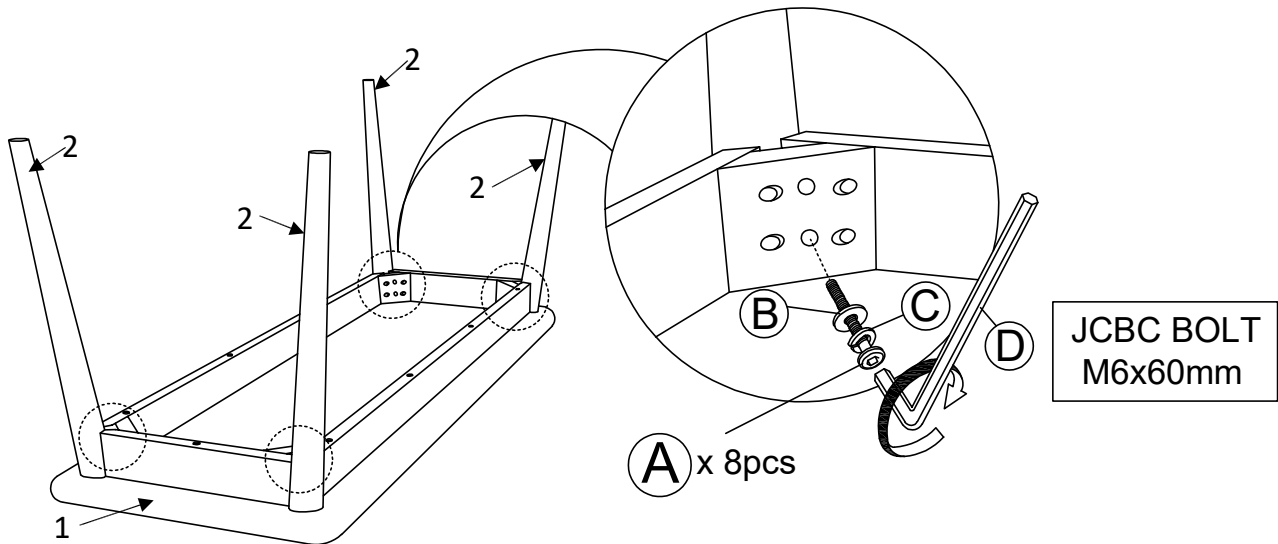

- Place Bench Top bottom-side up on a flat surface and material to prevent scratch and damage.
- Position a Leg against the corner of the bench aprons and align the screw holes on the leg to the screw holes on the corner block.
- Insert Screw (A) fitted with Spring Washer (C) and Flat Washer (B) through each hole on the corner block into the screw hole on the leg. Use Allen Key (D) to drive (A) to fasten the Leg to the corner block. Do not tighten (A) completely until both screws are in place on each leg. Do not over-tighten.
- Repeat the above assembly procedures (b & c) for the other three legs. Set the bench right - side up when all of the legs are assembled. The assembly of the bench is complete.

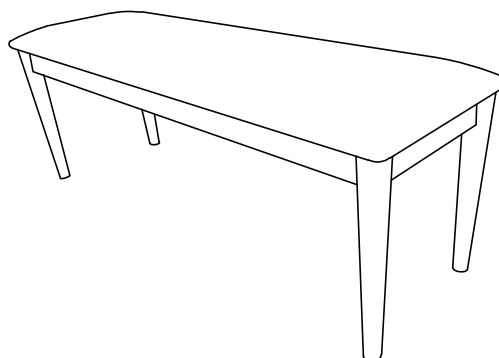

COMPLETED ASSEMBLY