

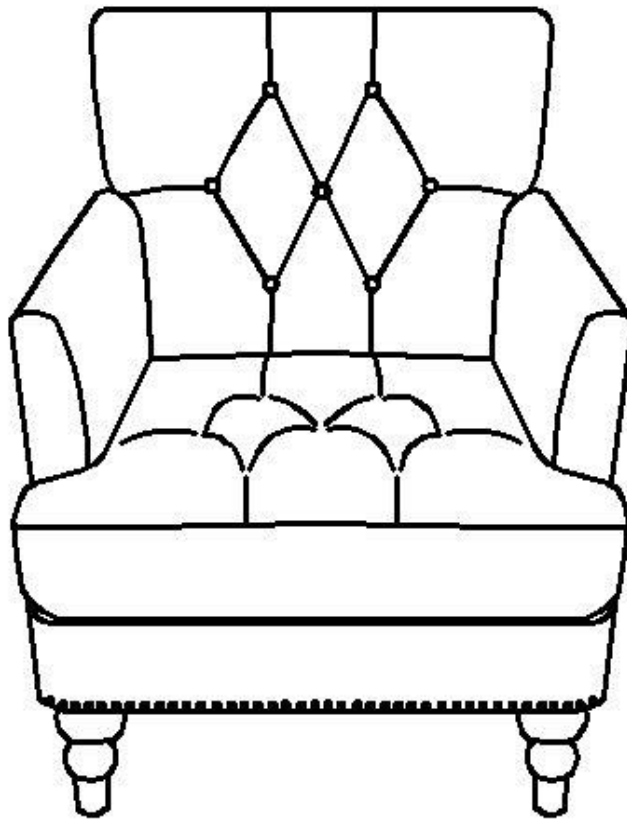



# Assembly Instructions

Caution : You must read this before you proceed

## Club Chair



## Parts List

Label	Picture	Description	QTY
A	 A1  A2	Chair : Seat Backrest (A1) and Seat Box ( A2)	A1-1PC A2-1PC
B	 Front Legs	Wooden Legs	2

C	 <b>Hind Legs</b>	Wooden Legs	2
---	---	-------------	---

## Hardware

Label	Picture	Description	QTY
1		Washer Rings	7

## Assembly Preparation

Before Beginning Assembly:

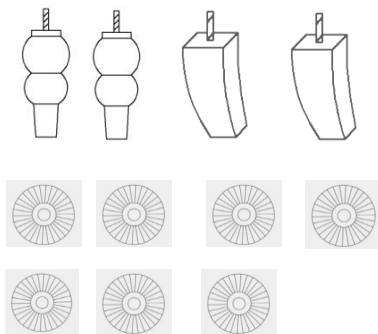
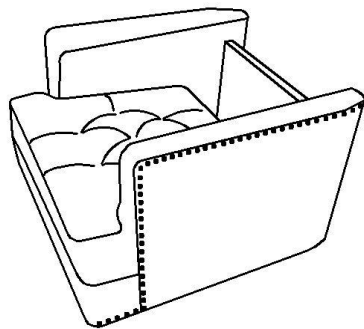
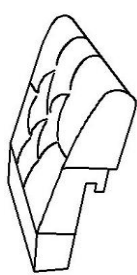

- Read instructions, cover to cover-



- Have 2 adults on hand for assembly-



- Do not assemble on flooring or carpet-



- Assemble on a clean non-marring surface (packing foam)-



- Save all packaging until finished-

# Assembly Steps

## Overview

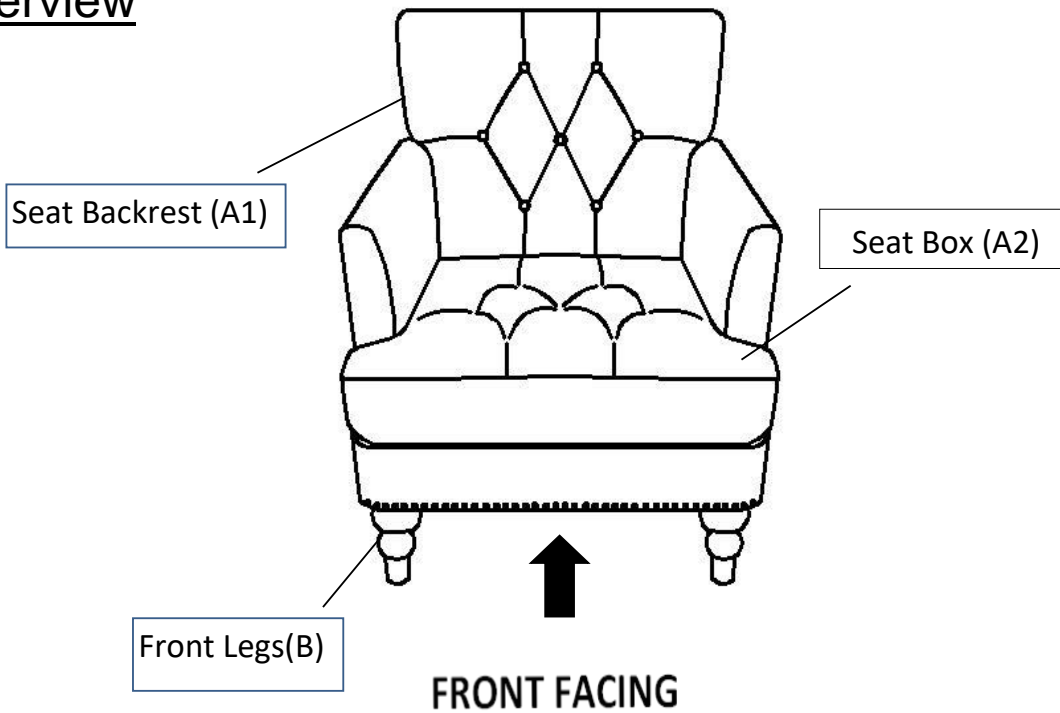

This Club Chair has multiple parts and may require up to 30 minutes to assemble. To give you an overview of the Club Chair parts, the above picture is to help you put the various parts into perspective. Please read through the instructions below to familiarise yourself with the parts and steps before assembly.

## Step 1

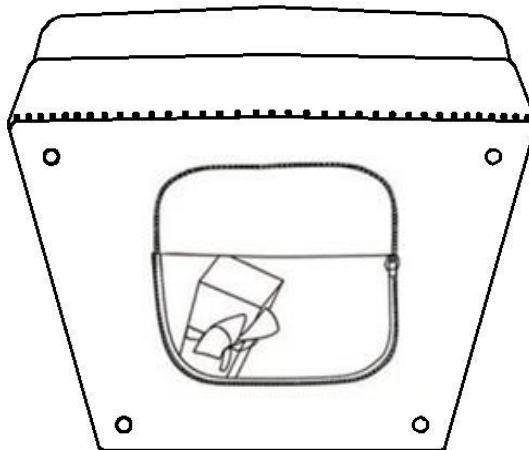

Position the Chair on its back, as shown.  
Unzip to open and remove the 4 wooden legs. Close the pouch.

## Step 2

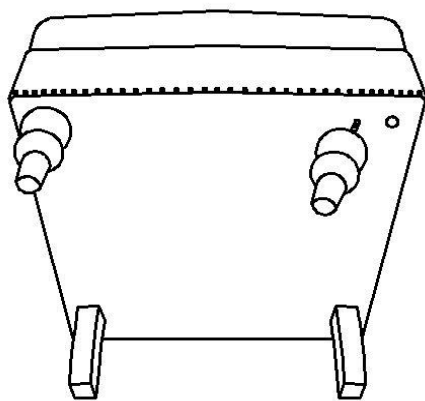

Insert the threaded Stem  
Into the threaded Hole.

Install the leg into the chair by putting a Washer Ring (improves tightness and security of leg) on the threaded stem, (The use of washer rings are OPTIONAL and is especially useful to help alleviate slight wobbliness);

Then insert the threaded stem into the threaded hole at each corner of the bottom of the chair.

Tighten by turning leg clockwise.

Repeat the same procedure to install the other 3 remaining legs.

## Step 3

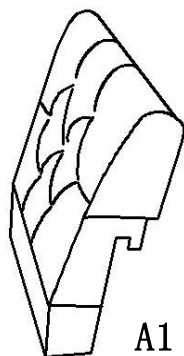

A1

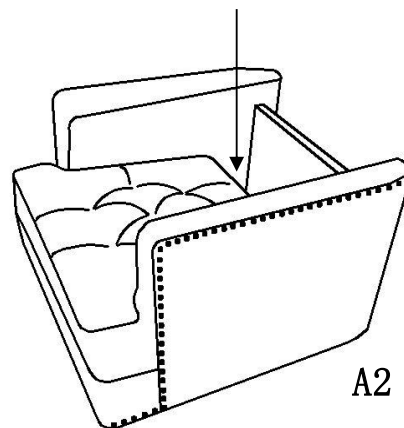

A2

Position yourself behind the chair.

Place the back rest(A1) into the body slot(A2).





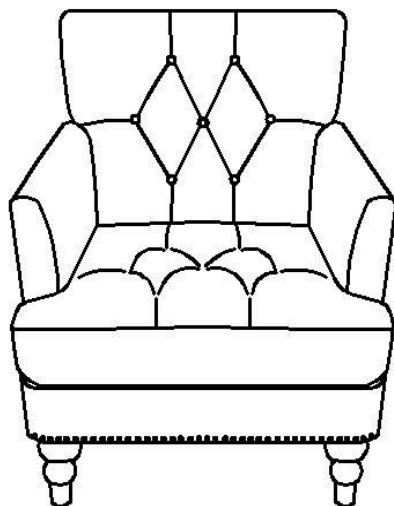





While tilting the back rest slightly forward. Then gently pull the back rest towards you while pushing it down all the way into the Chair Seat slot. located to the rear of the seat box. (as marked by the arrow above).

## Step 4



Make sure all parts are connected and securely locked into position.  
Your Club Chair is ready for use.  
This Club Chair can only be used on a flat, level surface.

## Care & Maintenance

-  ● Do not put hot items directly on furniture surface.
  -  ● Do not clean furniture with harsh cleansers or polish.
  -  ● Do not place furniture under direct sunlight.
  -  ● Do not place furniture near heating or cooling vents.
  -  ● Do not write on furniture without a padded barrier to protect the surface.
  -  ● Do not place furniture outside . For indoor use only.
  -  ● Not for commercial use. For residential use only.
  -  ● Stains may be removed with mild soap solution and damp cloth.
  -  ● Children should not climb or jump on the furniture.
- 
-  ● Dust and pick-up spills using a clean, non-colored, lint-free cloth.

### Questions & Answers about Proposition 65

#### • What is Proposition 65?

Proposition 65 requires businesses to provide warnings to Californians about significant exposures to chemicals that cause cancer, birth defects or other reproductive harm. These chemicals can be in the products that Californians purchase, in their homes or workplaces, or that are released into the environment. By requiring that this information be provided, Proposition 65 enables Californians to make informed decisions about their exposures to these chemicals.

Proposition 65 also prohibits California businesses from knowingly discharging significant amounts of listed chemicals into sources of drinking water.

Proposition 65 requires California to publish a list of chemicals known to cause cancer, birth defects or other reproductive harm. This list, which must be updated at least once a year, has grown to include approximately 900 chemicals since it was first published in 1987.

#### • What types of chemicals are on the Proposition 65 list?

The list contains a wide range of naturally occurring and synthetic chemicals that include additives or ingredients in pesticides, common household products, food, drugs, dyes, or solvents. Listed chemicals may also be used in manufacturing and construction, or they may be byproducts of chemical processes, such as motor vehicle exhaust.

#### • What does a warning mean?

If a warning is placed on a product label or posted or distributed at a workplace, a business, or in rental housing, the business issuing the warning is aware or believes that it is exposing individuals to one or more listed chemicals.

By law, a warning must be given for listed chemicals unless the exposure is low enough to pose no significant risk of cancer or is significantly below levels observed to cause birth defects or other reproductive harm.