

ASSEMBLY TIPS:

1. Remove hardware from box and sort by size.
2. Please check to see that all hardware and parts are present prior to start of assembly.
3. Please follow attached instructions in the same sequence as numbered to assure fast & easy assembly.

**Warning!**

1. Don't attempt to repair or modify parts that are broken or defective. Please contact the store immediately.
2. This product is for home use only and not intended for commercial establishments.



ASSEMBLY TIME	25 MINUTES
----------------------	-------------------

PARTS IDENTIFICATION**(BOX 1)**

	PART NAME	FIGURE	QTY
1	HEADBOARD PANEL		1PC
2L	LEFT HEADBOARD LEG		1PC
2R	RIGHT HEADBOARD LEG		1PC
8	HEADBOARD BOTTOM RAIL		1PC

(BOX 2)

3	FOOTBOARD		1PC
----------	-----------	--	-----

(BOX 3)

4L	LEFT BED RAIL		1PC
4R	RIGHT BED RAIL		1PC
5	CENTER RAIL		1PC
6	CENTER RAIL SUPPORT WITH LEVELER		2PCS



ASSEMBLY TIPS:

1. Remove hardware from box and sort by size.
2. Please check to see that all hardware and parts are present prior to start of assembly.
3. Please follow attached instructions in the same sequence as numbered to assure fast & easy assembly.

**Warning!**

1. Don't attempt to repair or modify parts that are broken or defective. Please contact the store immediately.
2. This product is for home use only and not intended for commercial establishments.

(BOX 4)

	PART NAME	FIGURE	QTY
7	ROLL SLAT (7 PCS)		2SETS
HB	FROM BOX 1 HEADBOARD COMPLETE		1 PC
3	FROM BOX 2 FOOTBOARD		1 PC











ASSEMBLY TIPS:

1. Remove hardware from box and sort by size.
2. Please check to see that all hardware and parts are present prior to start of assembly.
3. Please follow attached instructions in the same sequence as numbered to assure fast & easy assembly.

**Warning!**

1. Don't attempt to repair or modify parts that are broken or defective. Please contact the store immediately.
2. This product is for home use only and not intended for commercial establishments.

HARDWARE IDENTIFICATION**(BOX 1) - HARDWARE PACK**

	HARDWARE NAME	FIGURE	QTY
A	ALLEN WRENCH (M4 x 110mm - BLK)		1PC
B	LONG BOLT (M6 x 50mm - BLK)		12PCS
C	LOCK WASHER (5/16" - BLK)		12PCS
D	FLAT WASHER (5/16" x 18 x 1.2 - BLK)		12PCS
E	LONG FLAT HEAD SCREW (M4 x 32mm - BLK)		28PCS
F	SHORT BOLT (M6 x 40mm - BLK)		2PCS
G	SHORT FLAT HEAD SCREW (M4 x 20mm - BLK)		8PCS
H	WRENCH (2 x 24.5 x 85 - RBW)		1PC
I	HEX NUT (M6 - RBW)		2PCS
J	U BRACKET (26 x 63 x 70mm - RBW)		2PCS

**NOTE : PHILLIPS HEAD SCREW DRIVER IS REQUIRED IN THE ASSEMBLY PROCESS;
HOWEVER, MANUFACTURER DOES NOT PROVIDE THIS ITEM.**

STEP 1

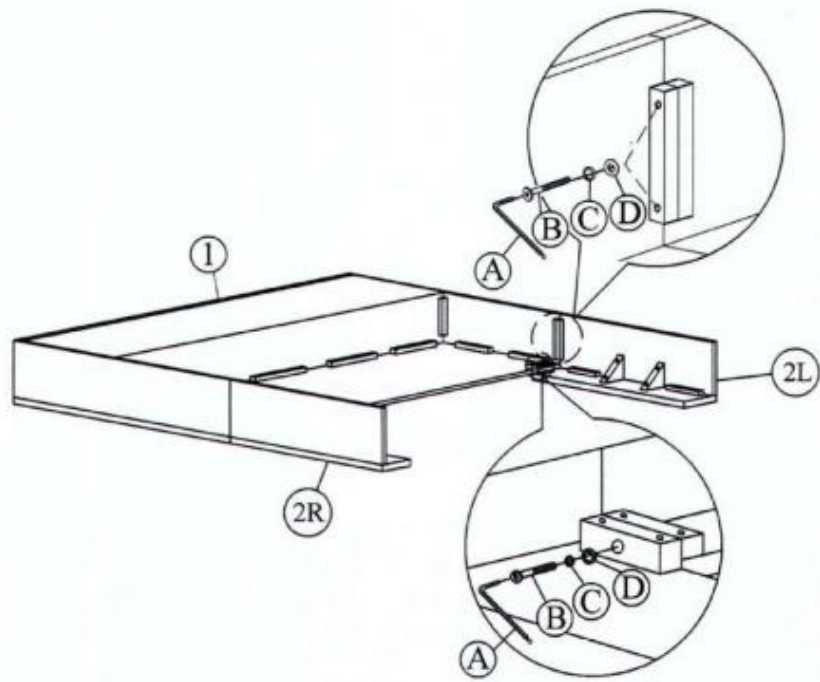

STEP 2

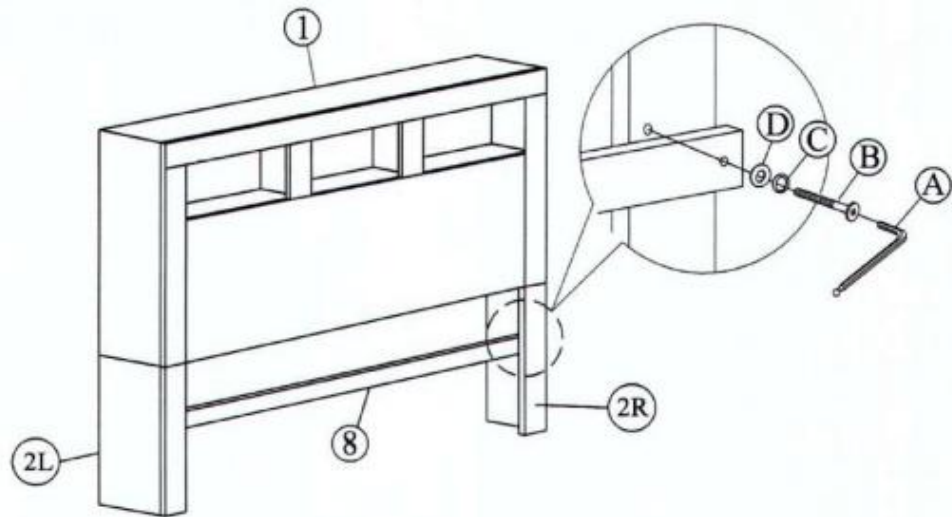

STEP 3

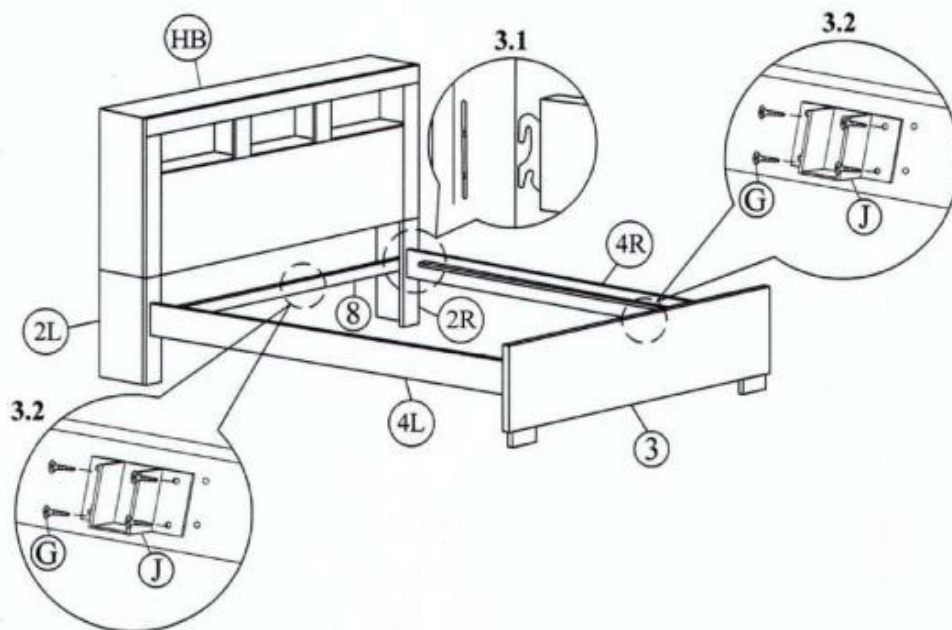

STEP 4

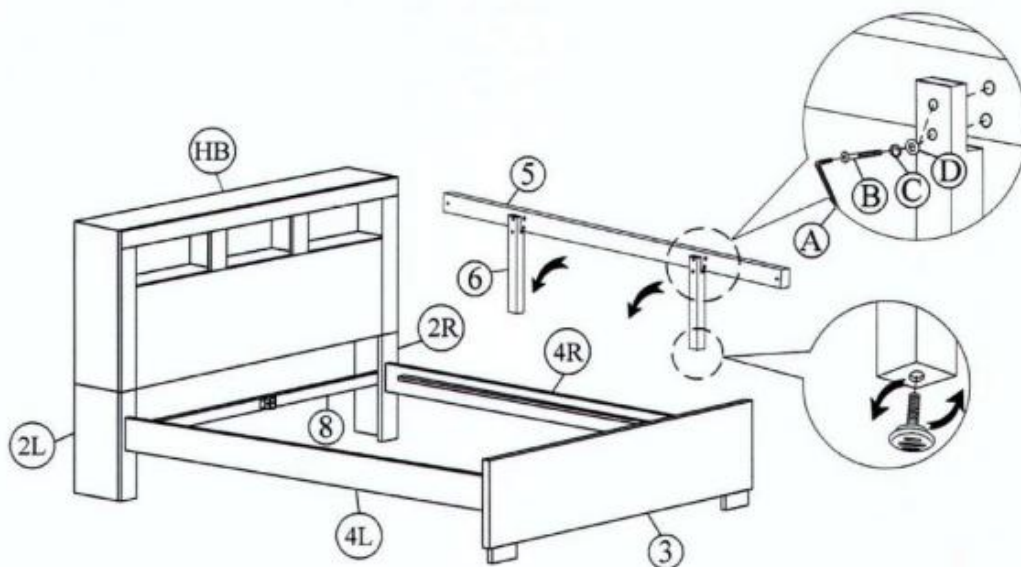

STEP 5

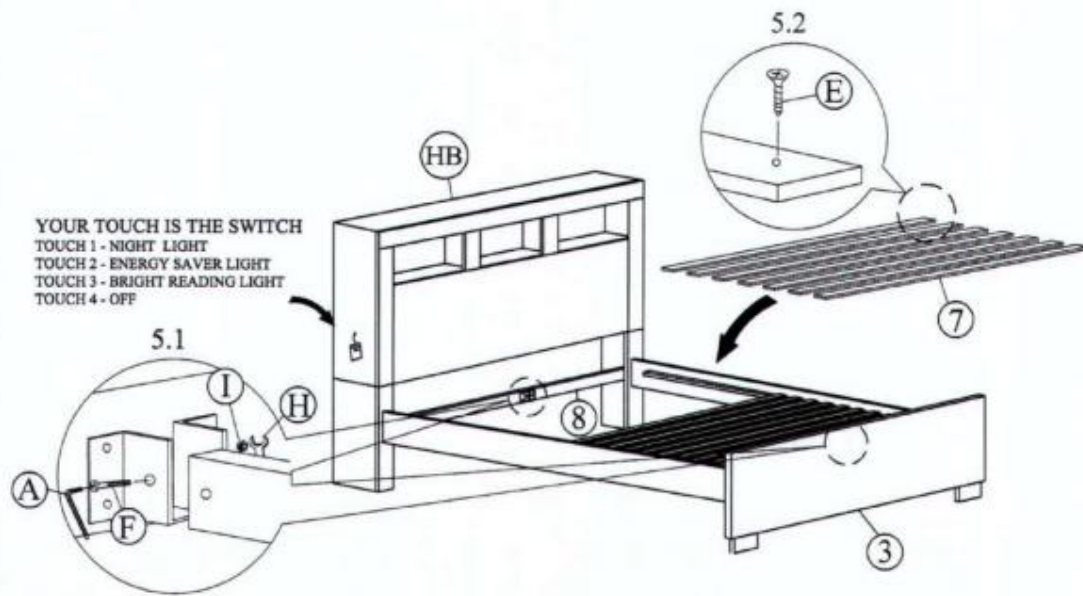

STEP 6 COMPLETE

