

Assembly Instructions

Instrucciones de ensamblaje

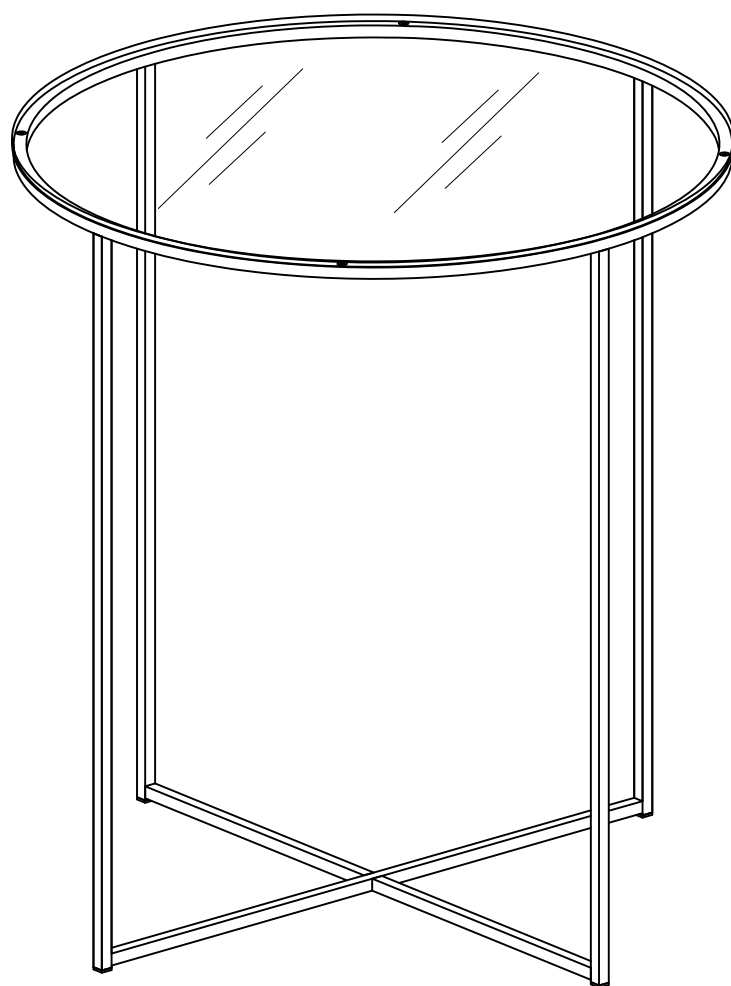

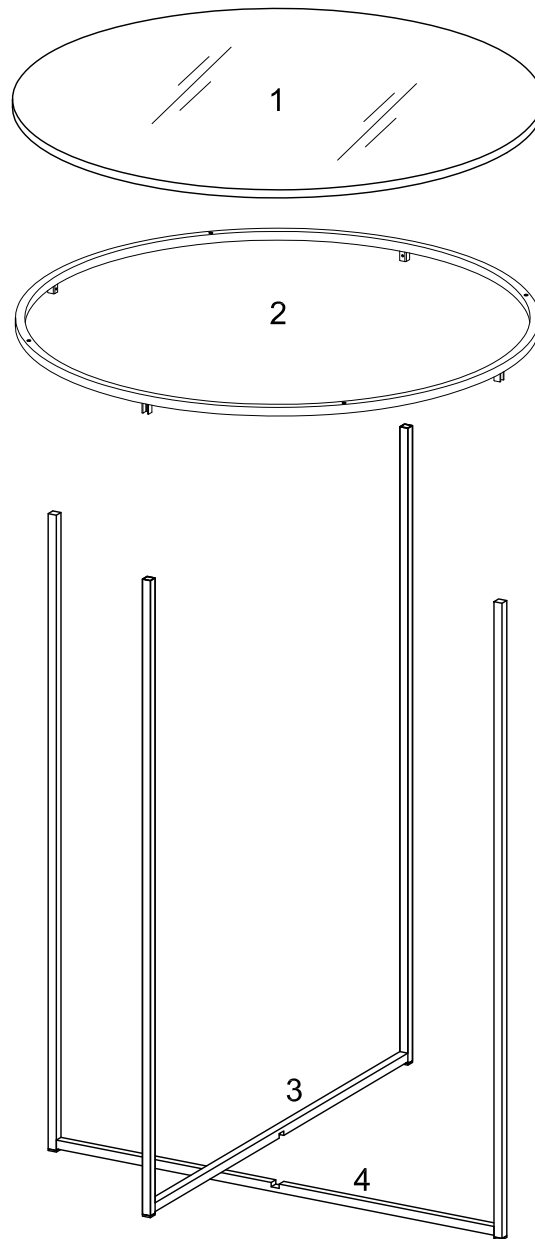

Parts List

Lista de piezas



Hardware List

Lista de materiales

A		M6x10mm	Bolt perno	5 pcs
B			Rubber suction cups ventosas de goma	4 pcs
C		M4mm	Wrench llave inglesa	1 pc

Step 1

Paso 1

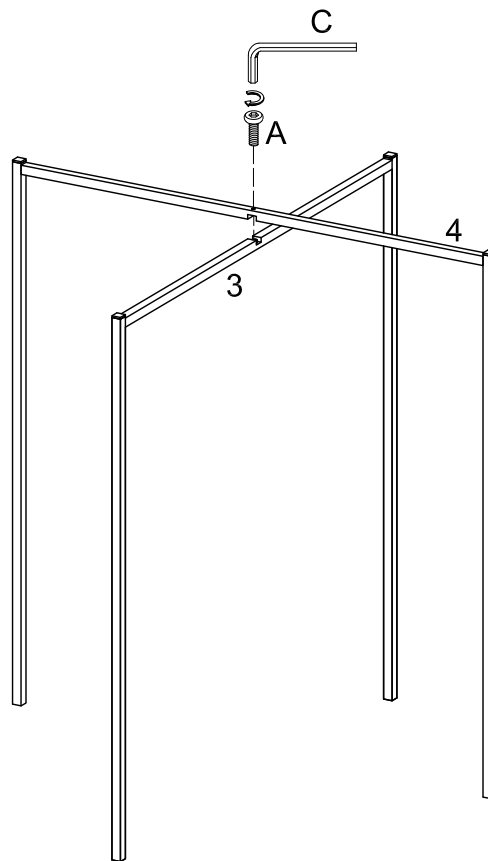

Use wrench (C), bolt (A) to secure the leg (3,4).

Use la llave inglesa (C) y el perno (A) para asegurar la pata (3,4).

Step 2

Paso 2

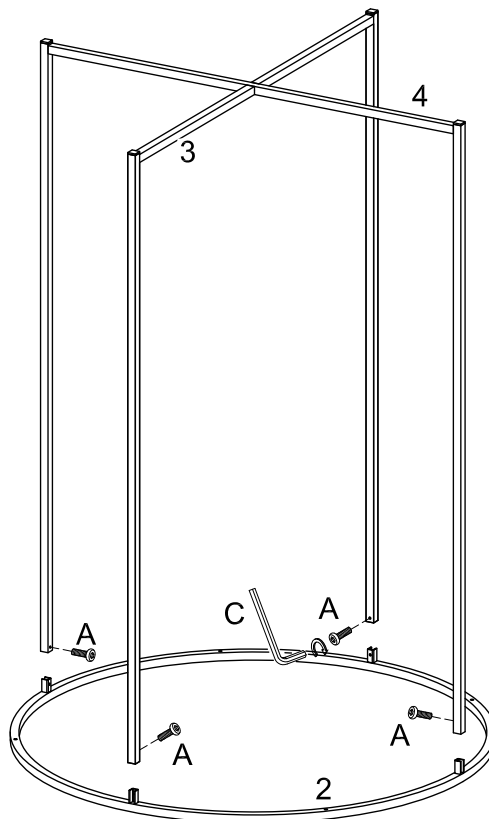

Use wrench (C), bolt (A) to secure the leg (3,4) to the table top frame (2).

Use la llave inglesa (C) y el perno (A) para asegurar la pata (3,4) al marco superior de la mesa (2).

Step 3

Paso 3

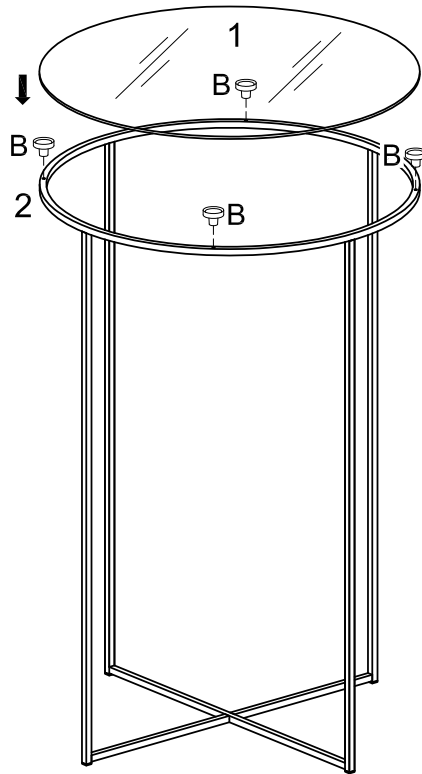

Insert the rubber suction cup (B), then place the glass (1) carefully on top of table top frame (2).
Inserte la ventosa de goma (B) y luego coloque el vidrio (1) cuidadosamente sobre el marco superior de la mesa (2).

Step 4

Paso 4

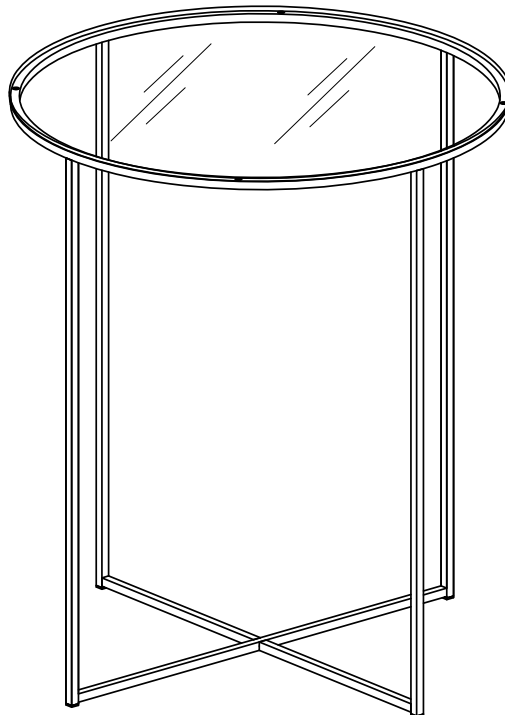

Final Assembly

Ensamblaje final