

Assembly Instruction

4 PIECE PATIO WICKER SOFA SET

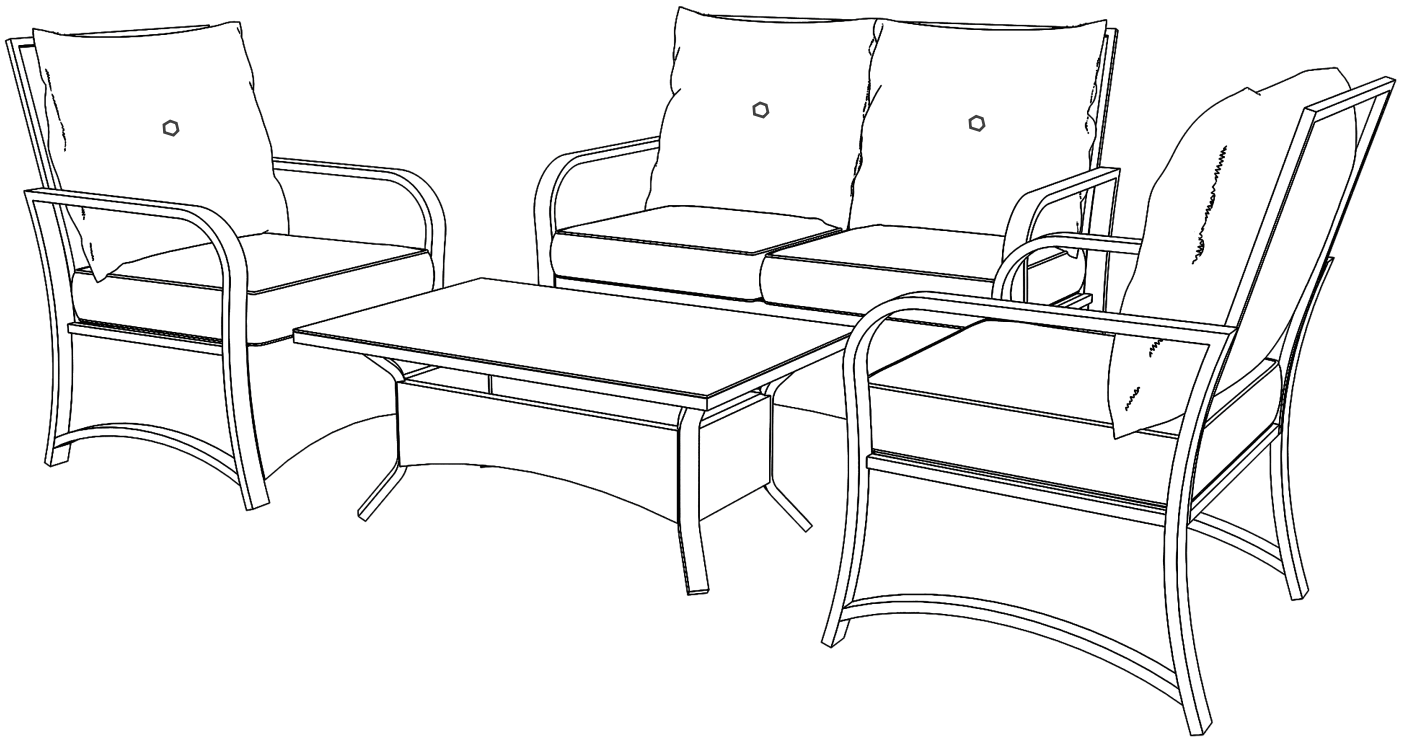









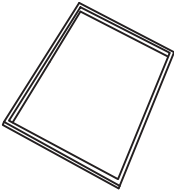
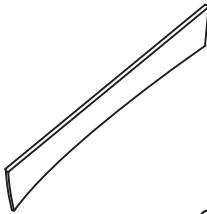
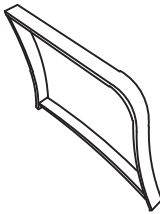
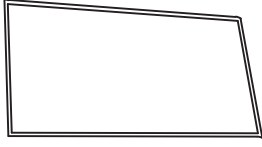
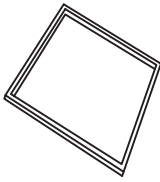

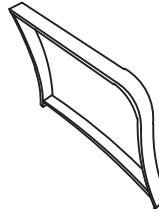
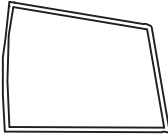
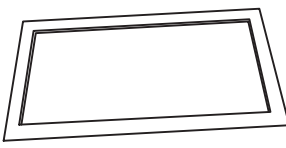
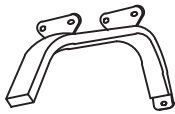
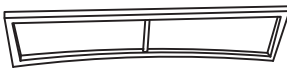
PRE-ASSEMBLY PREPARATION

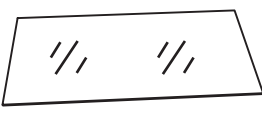
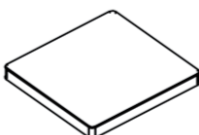
WARNING! DO NOT LET CHILDREN PLAY IN OR AROUND THE UNIT DUE TO THE POSSIBLE RISK OF FINGER ENTRAPMENT

- Please read through this instruction before beginning assembly.
- Two adults assembly is recommended.
- Clear out the space for assembly and lay out all parts base on Parts List, extra room will allow you to easily determine if all the pieces are present.
- Save all packing materials until assembly is complete to avoid accidentally discarding smaller parts or hardware.
- Keep small parts and pieces away from children until fully assembly.
- **Do not fully tighten the bolts until all have been inserted and hand tightened.**
- Please check for any loose screws and tighten them before use.

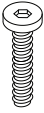
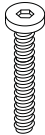
PANEL AND FITTINGS IDENTIFICATION

| | | | |
|--|---|---|---|
| <p>Seat Panel (A1)</p>  <p>Qty: 1</p> | <p>Front Panel (B1)</p>  <p>Qty: 1</p> | <p>Right Armrest (C1)</p>  <p>Qty: 3</p> | <p>Backrest Panel (D1)</p>  <p>Qty: 1</p> |
| <p>Seat Panel (A2)</p>  <p>Qty: 2</p> | <p>Front Panel (B2)</p>  <p>Qty: 2</p> | <p>Left Armrest (C2)</p>  <p>Qty: 3</p> | <p>Backrest Panel (D2)</p>  <p>Qty: 2</p> |
| <p>Table Top (E)</p>  <p>Qty: 1</p> | <p>Table Legs (F)</p>  <p>Qty: 4</p> | <p>Table Front Panel (G)</p>  <p>Qty: 2</p> | <p>Table Side Panel (H)</p>  <p>Qty: 2</p> |
| <p>Table Glass Top (I)</p>  <p>Qty: 1</p> | <p>Seat Cushion</p>  <p>Qty: 4</p> | <p>Back Cushion</p>  <p>Qty: 4</p> | |

| HARDWARE LIST | | | |
|---|---|---|--|
| Bolt (J)  M6 x 20mm Qty: 20 | Bolt (K)  M6 x 40mm Qty: 28 | Bolt (L)  M6 x 50mm Qty: 12 | Washer (M)  Qty: 60 |
| Plastic Cap (N)  Qty: 60 | Wrench (O)  Qty: 1 | | |

**NOTE: From step 1 to step 4 is for loveseat sofa assembly.
Please find panel A1, B1, C1, C2 and D1 firstly.**

Step 1 Attach Seat Panel (A1) to Front Panel (B1) by using 4 medium Bolts (K) and 4 Washer (M). Finally put Bolt Caps (N) until all parts have been connected and bolts are tightened.

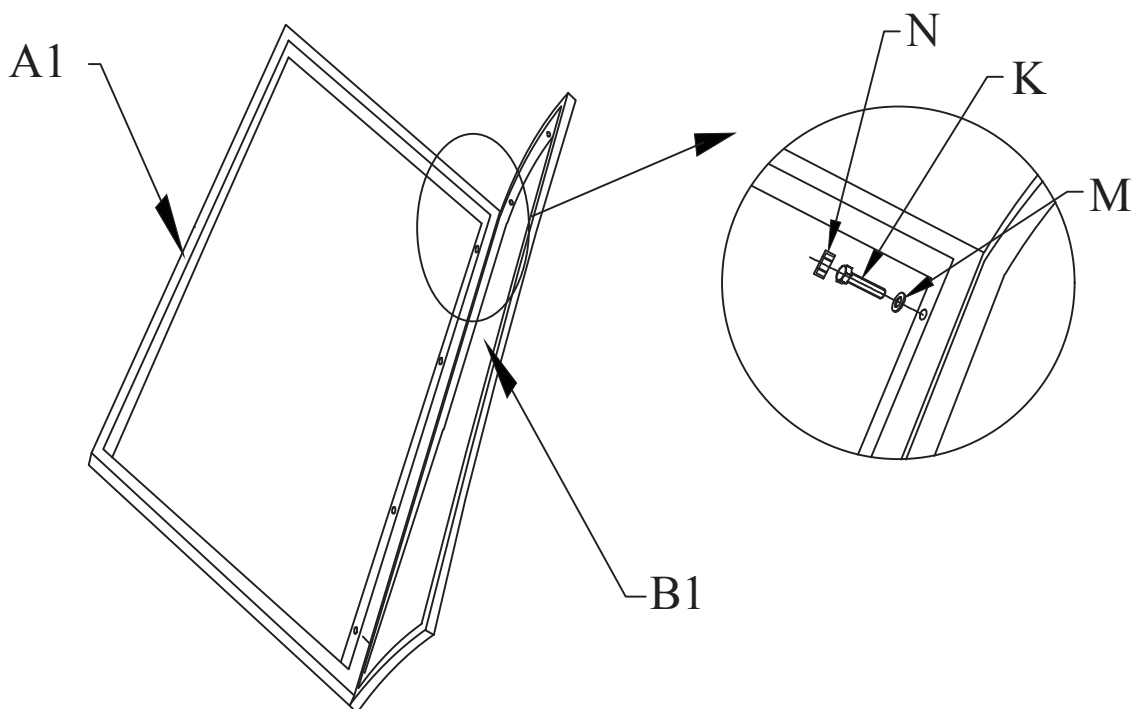

Step 2 Attach Right Armrest (C1) and Left Armrest (C2) to Front Panel on both side by using 4 medium Bolts (K) and 4 Washers (M).
Finally put Bolt Caps (N) until all parts have been connected and bolts are tightened.

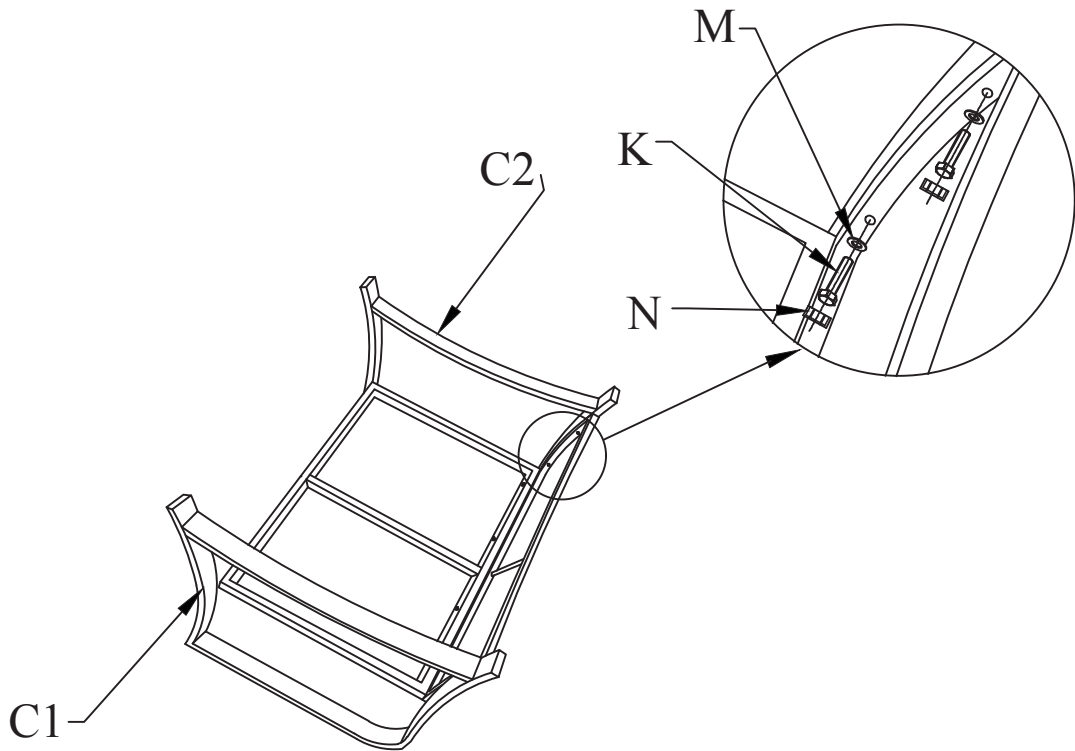

Step 3 Attach Backrest Panel (D1) to the Seat Panel by using 4 medium Bolts (K) and 4 Washers (M).
Finally put Bolt Caps (N) until all parts have been connected and bolts are tightened.

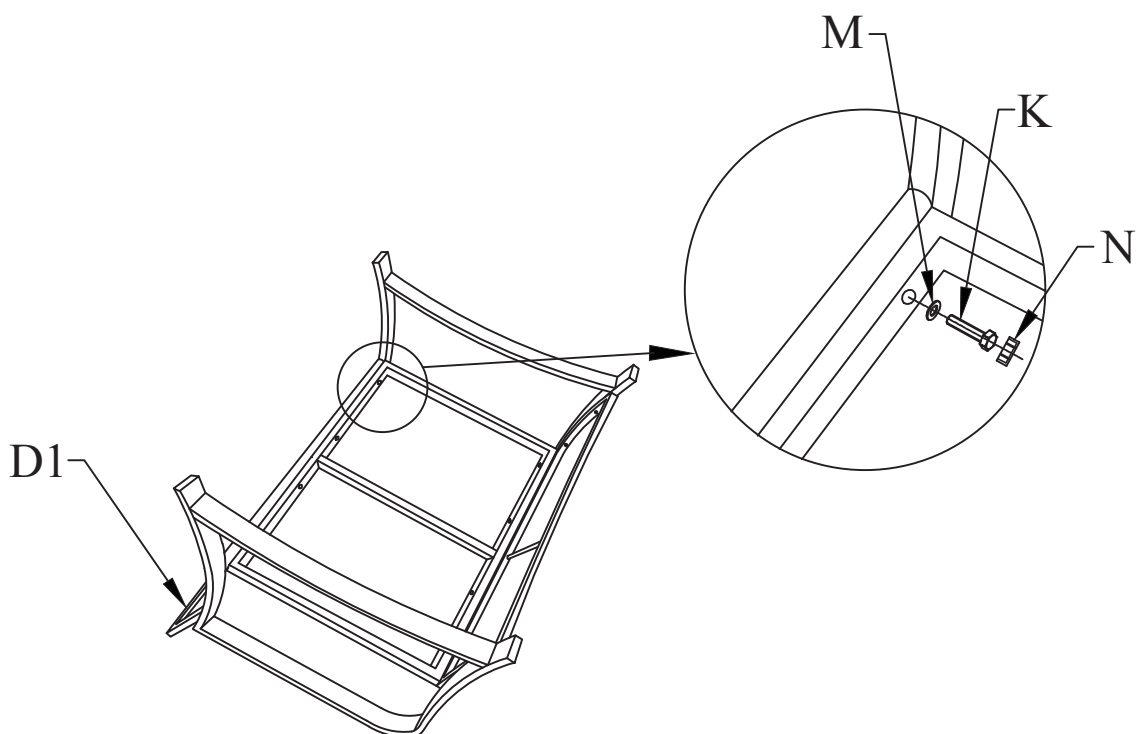

Step 4 Attach Backrest Panel (D1) to the Armrest Panels on both side by using 4 long Bolts (L) and 4 Washers (M).
Finally put Bolt Caps (N) until all parts have been connected and bolts are tightened.

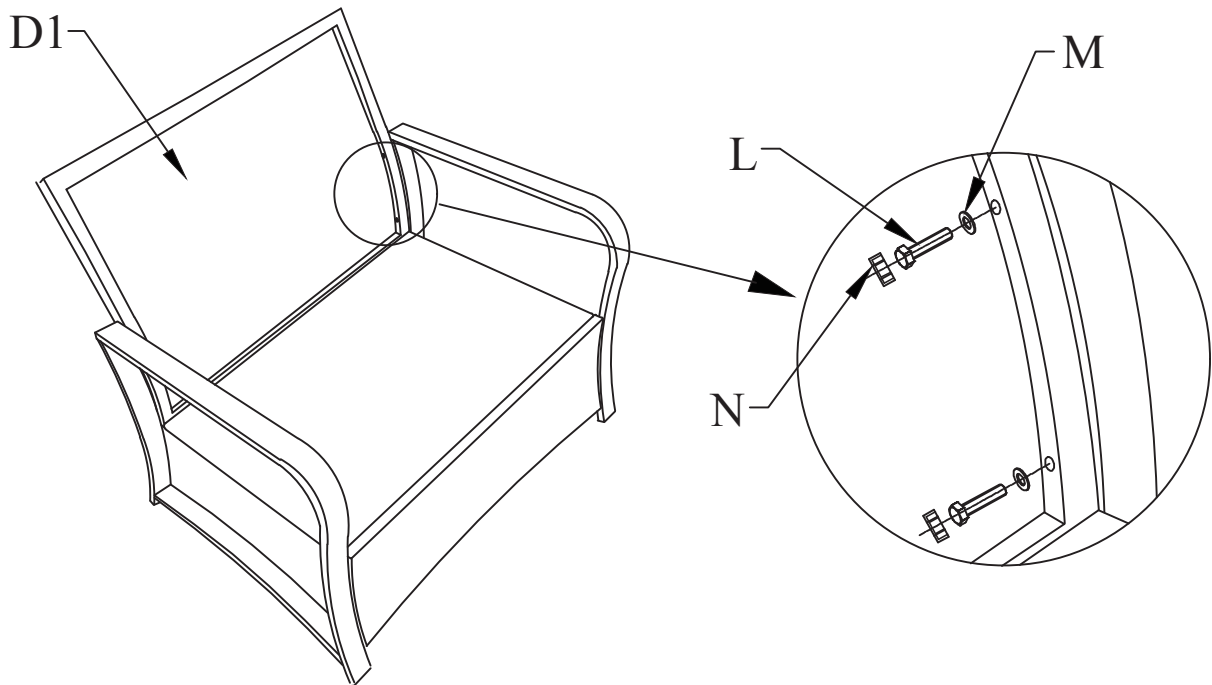

NOTE: From step 5 to step 8 is for single sofa assembly, the way is similar to loveset sofa.
Please find panel A2, B2, C1, C2 and D2 firstly.

Step 5 Attach Seat Panel (A2) to Front Panel (B2) by using 2 medium Bolts (K) and 2 Washers (M).
Finally put Bolt Caps (N) until all parts have been connected and bolts are tightened.

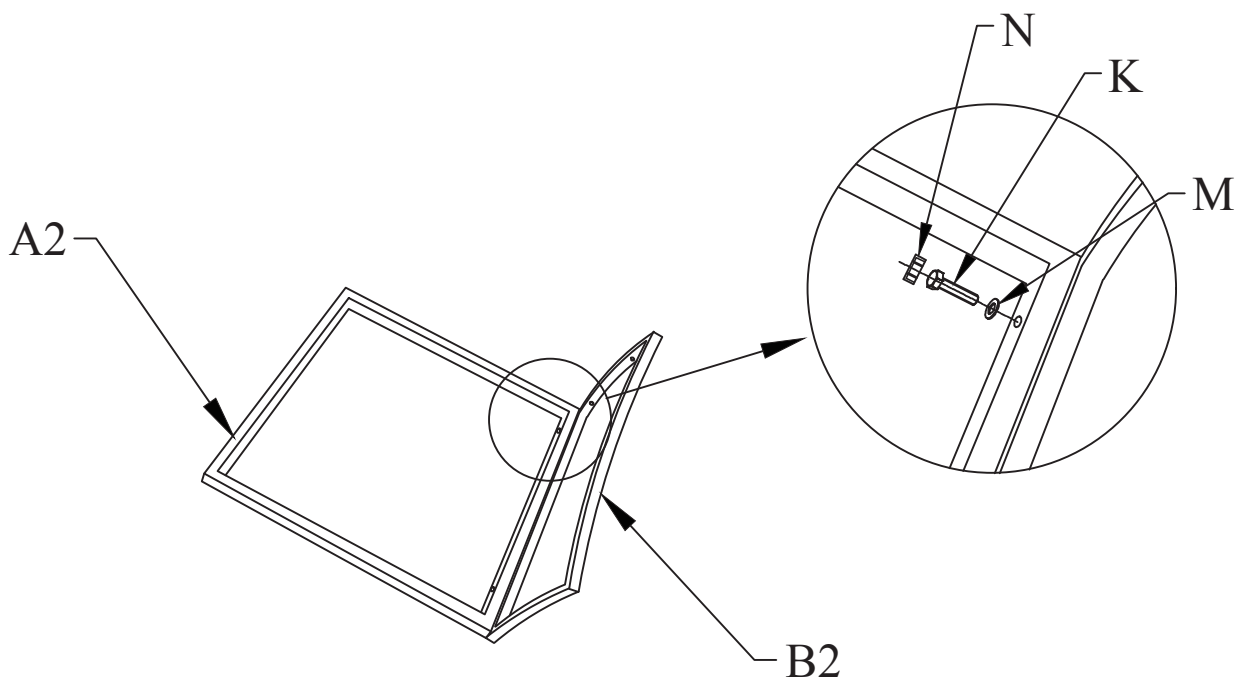

Step 6 Attach Right Armrest (C1) and Left Armrest (C2) to Front Panel on both sides by using 4 medium Bolts (K) and 4 Washers (M).
Finally put Bolt Caps (N) until all parts have been connected and bolts are tightened.

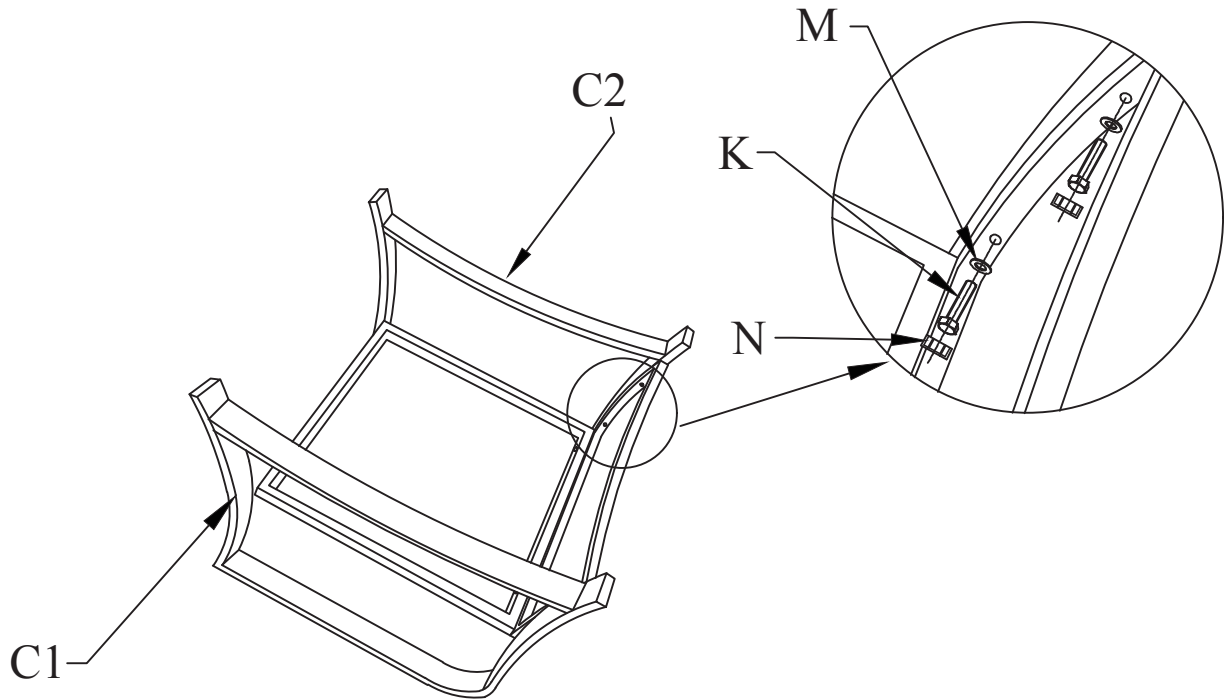

Step 7 Attach Backrest Panel (D2) to the Seat Panel by using 2 medium Bolts (K) and 2 Washers (M).
Finally put Bolt Caps (N) until all parts have been connected and bolts are tightened.

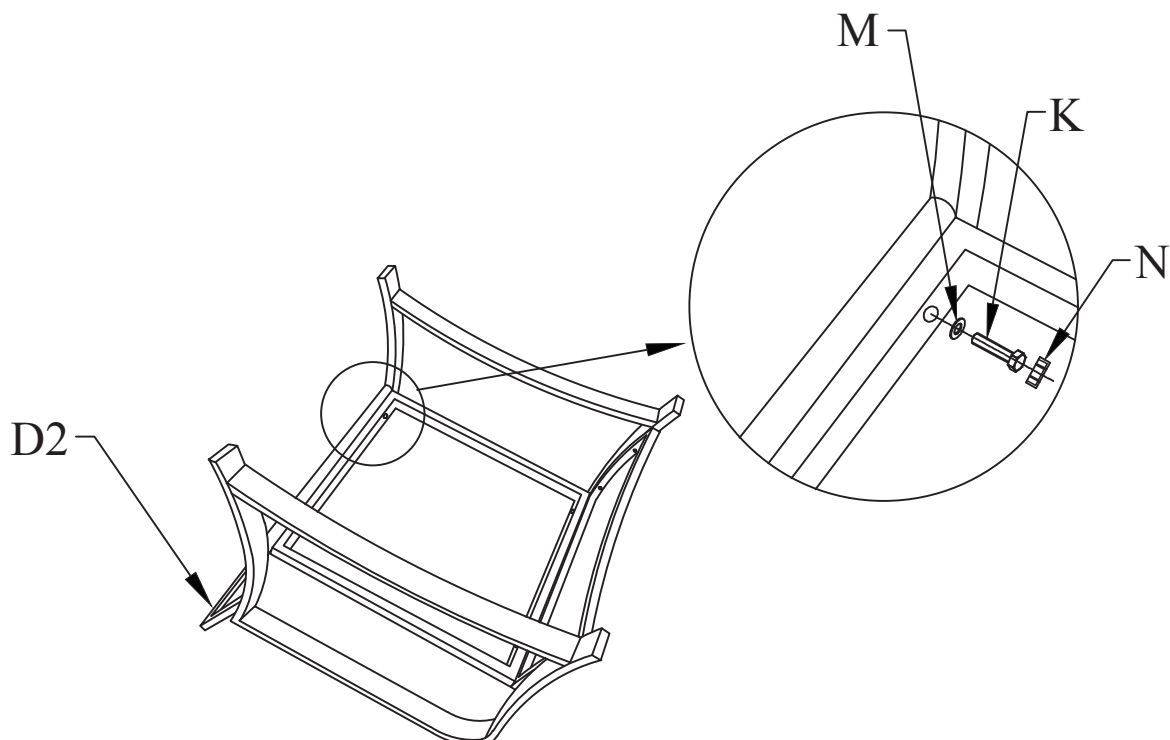

Step 8 Attach Backrest Panel (D2) to the Armrest Panels on both side by using 4 long Bolts (L) and 4 Washers (M).

Finally put bolt caps (N) until all parts have been connected and bolts are tightened.

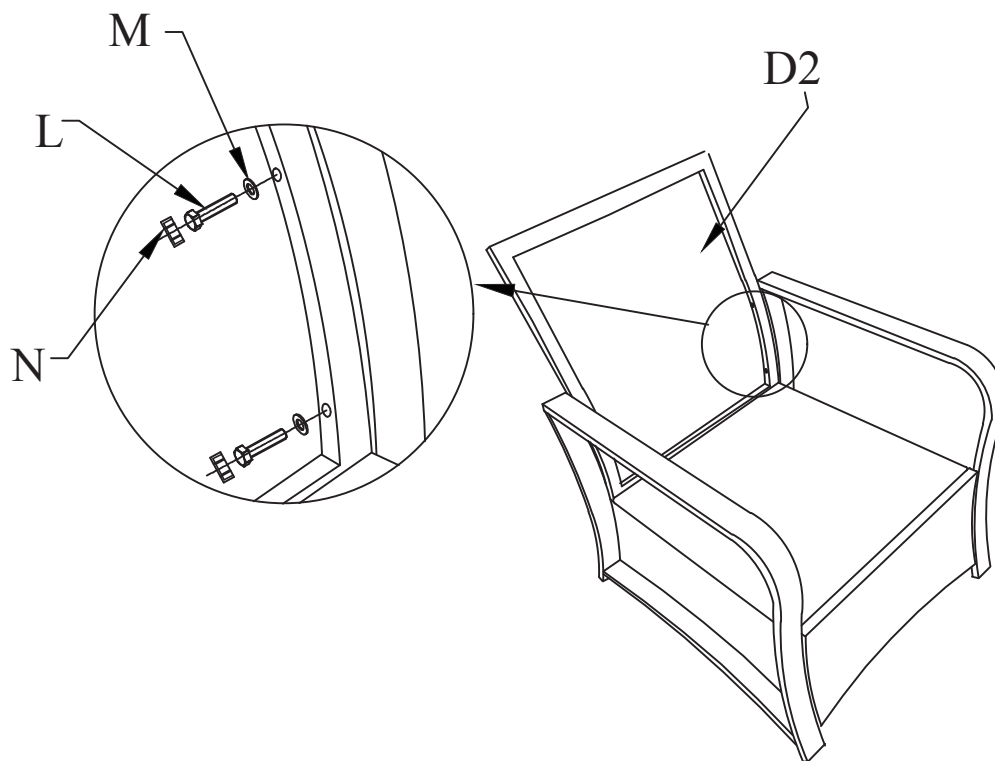

**NOTE: From step 9 to step 11 is for table assembly.
Please find panel E, F, G, H and I firstly.**

Step 9 Attach 4 Table Legs (F) to the Table Top (E) by using 4 short Bolts (J) and 4 Washers (M).
Finally put Bolt Caps (N) until all parts have been connected and bolts are tightened.

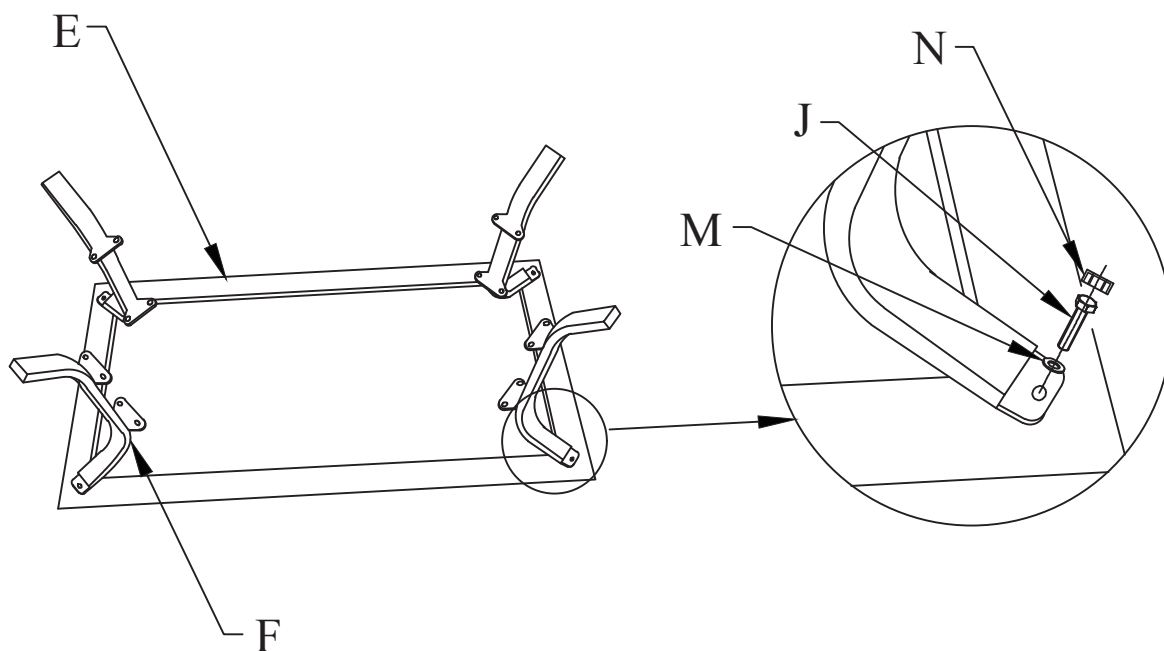

Step 10 Attach 2 Front Panels (G) and 2 Side Panels (H) to the table legs down by using 8 short Bolts (J) and 8 Washers (M).
Finally put Bolt Caps (N) until all parts have been connected and bolts are tightened.

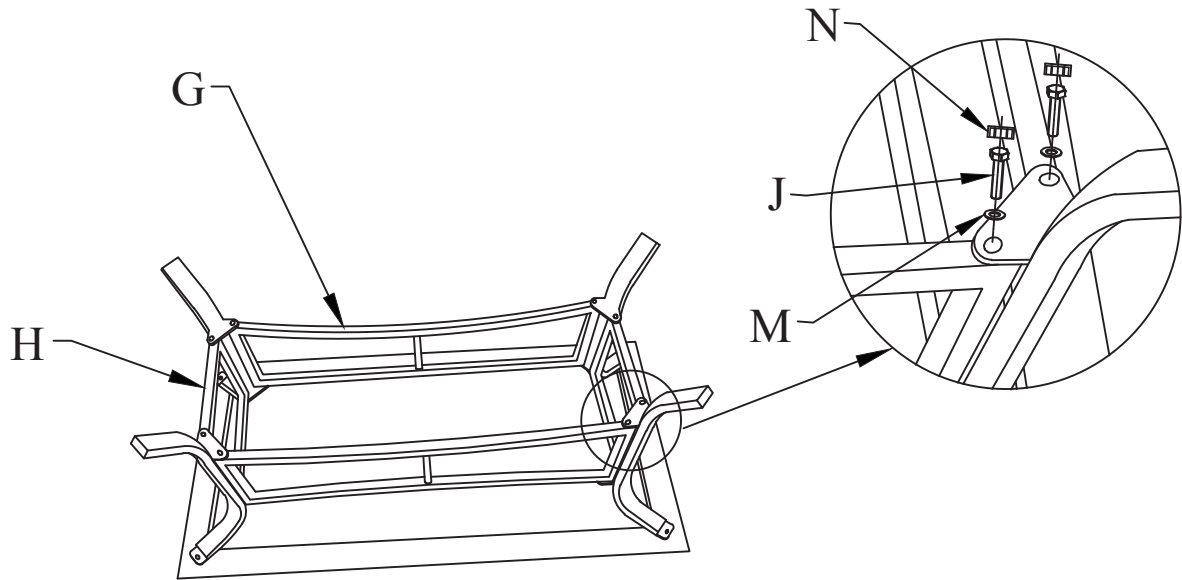

Step 11 Fix each panels to the table legs up by using 8 short Bolts (J) and 8 Washers (M).
Finally put Bolt Caps (N) until all parts have been connected and bolts are tightened.

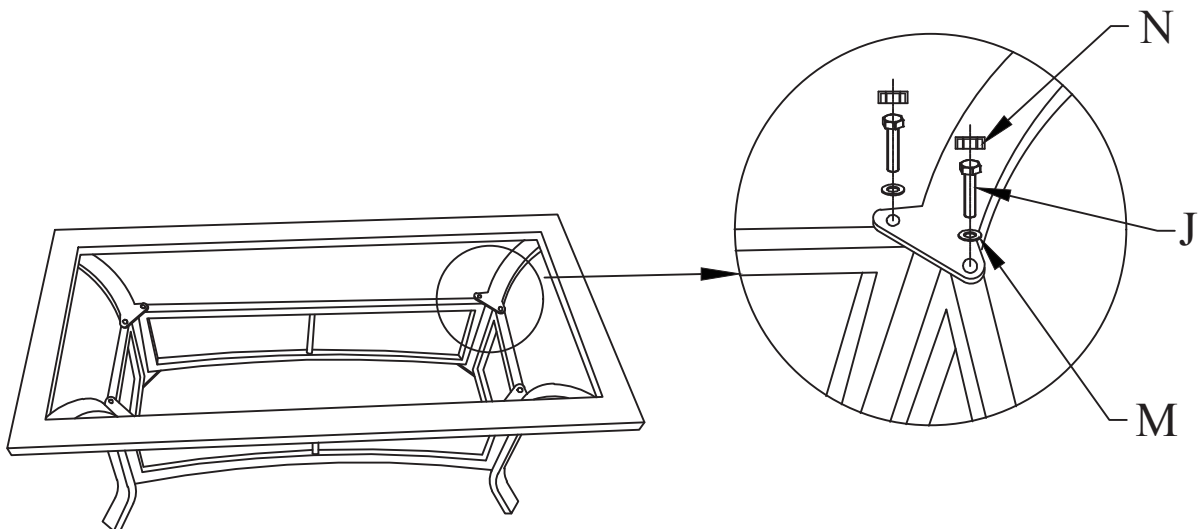

Step 12 Put Glass Top (I) to the table stand.

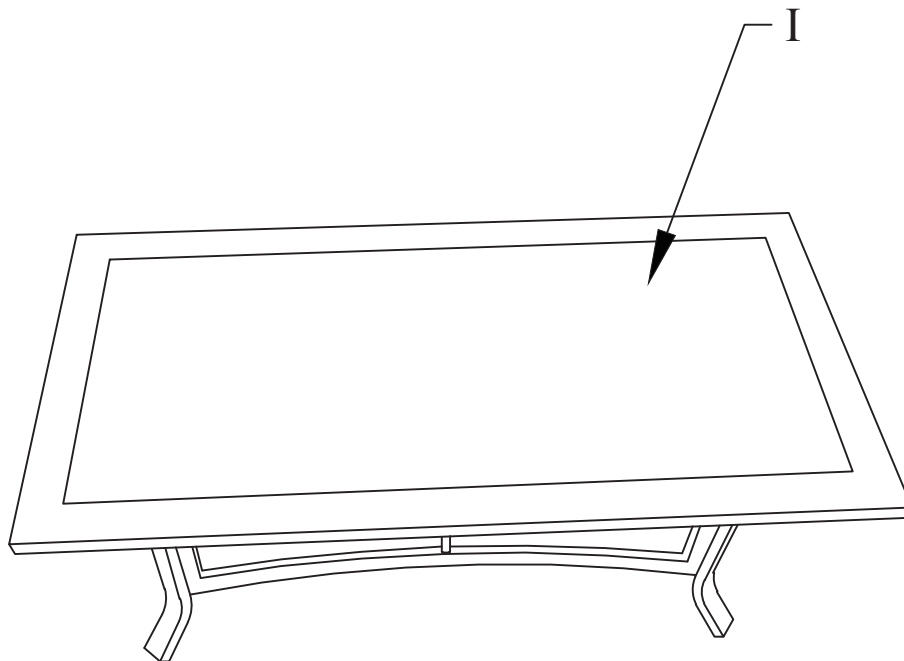

Step 13 Put on seat cushion and back cushion.
Please make sure all bolts are properly tightened before use.

