

**YFR003**

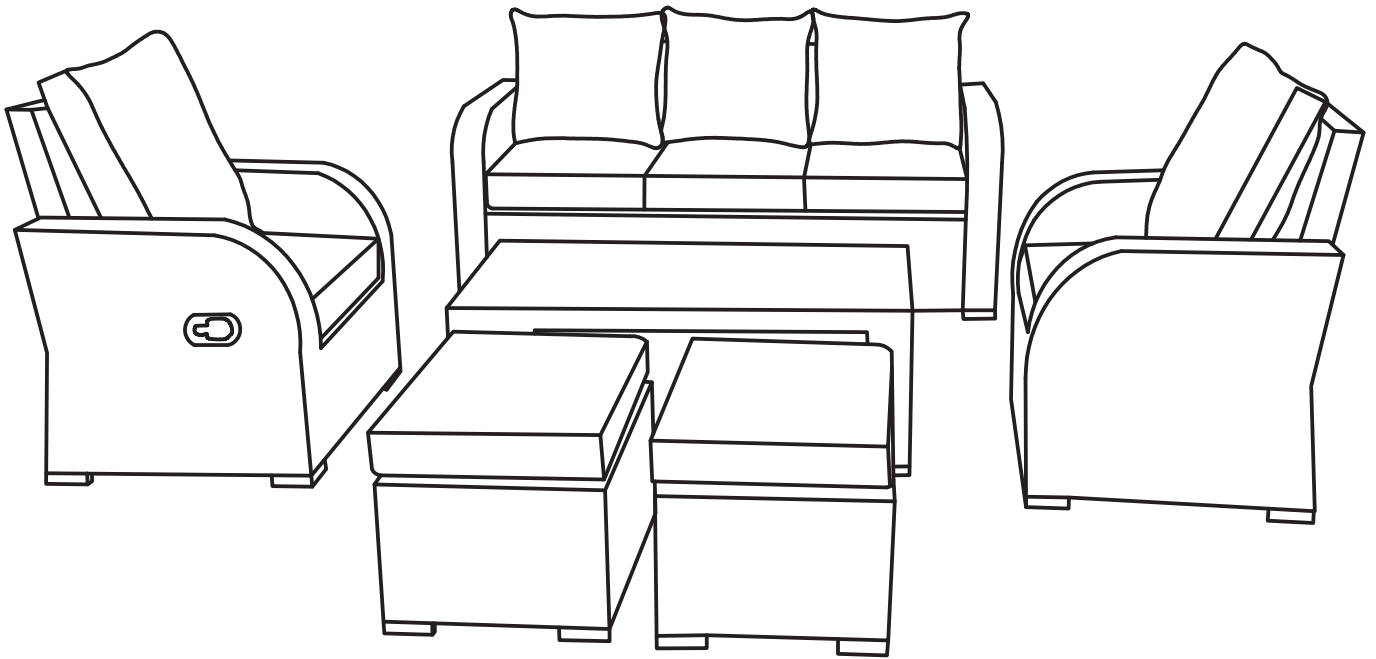

READ AND SAVE THIS INSTRUCTIONS FOR FUTURE USE

# ASSEMBLY & INSTRUCTION MANUAL

# Garden Chairs

## **IMPORTANT-KEEP THIS INFORMATION FOR YOUR SUBSEQUENT CONSULTATION: READ CAREFULLY**

**Only for domestic use**

### **Use tips:**

- \*Put the chair stably on a flat floor.
- \*Mount the garden chairs in the shelter of the weather.
- \*Stay away from open flames.
- \*Don't hang anything in the structure.
- \*Avoid the overload at the anchors/structure.
- \*It is advised that don't stay on the chairs when there is a storm.
- \*It is recommended to protect in case of strong wind or rain and in your absence.

### **Precautions before assembly:**

- \*Prepare a clean and dry mounting area.
- \*Verify that the product is not damaged.
- \*Check that none of the pieces are missing.

### **Maintenance:**

- \*Clean with a soft fabric.
- \*Regularly remove leaves and / or water collected on the canvas.
- \*Check the chair regularly.

### **Storage conditions:**

\*The fabric should be stored completely dry, in a clean and dry place to avoid the risks of mold.

### **Caution with the risks of pinching or cuts during assembly.**

**The manufacturer declines all responsibility in case of damages due to a bad installation or due to weather.**

# Chaises de jardin

**IMPORTANT - CONSERVEZ CES INFORMATIONS POUR VOTRE CONSULTATION ULTÉRIEURE: LISEZ ATTENTIVEMENT**

**Seulement pour usage domestique**

**Conseils:**

- \* Placez la chaise de manière stable sur un sol plat.
- \* Installez les chaises de jardin à l'abri des intempéries.
- \* Restez à l'écart des flammes ouvertes.
- \* Ne rien accrocher dans la structure.
- \* Évitez de surcharger les extrémités de la structure
- \* Il est conseillé de ne pas rester sur la chaise en cas d'orage.
- \* Il est recommandé de la protéger en cas de vent fort ou de pluie et en votre absence.

**Précautions avant l'assemblage:**

- \* Préparez une zone de montage propre et sèche.
- \* Vérifiez que le produit n'est pas endommagé.
- \* Vérifiez qu'aucun des morceaux ne manque.

**Entretien:**

- \* Nettoyer avec un tissu doux.
- \* Enlevez régulièrement les feuilles et / ou l'eau recueillie sur la toile.
- \* Vérifiez la chaise fréquemment.

**Conditions de stockage:**

- \* Le tissu doit être stocké complètement à sec, dans un endroit propre et sec pour éviter les risques de moisissure.

**Attention aux risques de pincement ou de coupure lors du montage.**

**Le fabricant décline toute responsabilité en cas de dommage dû à une mauvaise installation ou aux intempéries.**

# Sillas para Jardín

## **IMPORTANTE-CONSERVE ESTA INFORMACIÓN PARA SU CONSULTA POSTERIOR: LEER DETALLA DAMENTE**

**Solamente para uso doméstico**

### **Consejos de uso:**

- \*Coloque el balancín de forma estable sobre un suelo plano.
- \*Monte las sillas de jardín en el toldo.
- \*Manténgase alejado de llamas abiertas.
- \*No cuelgue nada en la estructura.
- \*Envite la sobrecarga en los anclajes.
- \*Se aconseja no permanecer en el balancín cuando hay tormenta.
- \*Se recomienda resguardar en caso de viento o lluvia fuerte y en su ausencia.

### **Precauciones antes del montaje:**

- \*Prepare una zona de montaje limpia y seca.
- \*Verificar que el producto no este dañado.
- \*Controlar que no falta ninguna de las piezas.

### **Mantenimiento:**

- \*Limpiar con la ayuda de un paño suave.
- \*Eliminar regularmente las hojas y/o agua recogidas sobre la lona.
- \*Inspeccione las sillas regularmente.

### **Condiciones de almacenaje:**

- \*La tela debe ser guardada totalmente seca, en un lugar limpio y seco para evitar los riesgos de moho.

**Precaución con los riesgos de pinzamientos o cortes durante el montaje.**

**El fabricante declina toda responsabilidad en caso de deterioros debidos a una mala instalación o por causas meteorológicas.**

# Gartenstühle

## **WICHTIG – BITTE HEBEN SIE DIESE ANLEITUNG FÜR EINE SPÄTERE BEZUGNAHME AUF: SORGFÄLTIG DURCHLESEN**

### **Nur für den häuslichen Gebrauch bestimmt**

#### **Nutzungshinweise:**

- \* Bitte stellen Sie die Schaukel stabil auf eine ebene Fläche.
- \* Stellen Sie die Stühle an einen wettergeschützten Ort.
- \* Von offenen Feuerquellen fernhalten.
- \* Hängen Sie nichts an die Struktur.
- \* Vermeiden Sie eine Überlastung der Anker.
- \* Es wird empfohlen, die Schaukel bei schlechten Wetterbedingungen nicht zu benutzen.
- \* Es wird empfohlen, die Schaukel während Ihrer Abwesenheit vor starkem Regen oder starkem Wind zu schützen.

#### **Vorsichtsmaßnahmen vor der Montage:**

- \* Bitte bereiten Sie einen sauberen und trockenen Montagebereich vor.
- \* Stellen Sie sicher, dass das Produkt nicht beschädigt ist.
- \* Vergewissern Sie sich, dass keines der Zubehöerteile fehlt.

#### **Instandhaltung:**

- \* Bitte reinigen Sie die Schaukel nur mit einem weichen Tuch.
- \* Bitte entfernen Sie regelmäßig alle Blätter und / oder Wasser, die sich auf dem Stoff angesammelt haben.
- \* Überprüfen Sie die Gartenstühle regelmässig.

#### **Lagerung:**

- \* Der Stoff sollte an einem völlig trockenen und sauberen Ort aufbewahrt werden, um Schimmel zu vermeiden.

#### **Vorsicht vor Quetsch- und Schnittgefahr bei der Montage.**

**Der Hersteller lehnt jede Haftung für Schäden ab, die durch unsachgemäße Installation oder Witterungseinflüsse verursacht wurden.**

# Sedie da giardino

## **IMPORTANTE-CONSERVARE QUESTE INFORMAZIONI PER CONSULTARLE IN SEGUITO: LEGGERE ATTENTAMENTE**

### **Solo per uso domestico**

#### **Consigli per l'uso:**

- \*Posizionare l'altalena saldamente su una superficie piana.
- \*Montare le sedie da giardino al riparo dalle intemperie del tempo.
- \*Tenere lontano dal fuoco.
- \*Non appendere alcun oggetto alla struttura.
- \*Evitare di sovraccaricare le giunture.
- \*E' consigliabile di non utilizzare l'altalena quando fuori c'e' un temporale.
- \*E' consigliabile di proteggere l'altalena dalla pioggia o da forti venti in vostra assenza.

#### **Precauzioni prima del montaggio:**

- \*Preparare un'area di assemblaggio pulita e asciutta.
- \*Verificare che il prodotto non sia danneggiato.
- \*Controllare che nessun pezzo manchi.

#### **Manutenzione:**

- \*Pulire con un panno morbido.
- \*Rimuovere regolarmente foglie e / o acqua depositata sul telo.
- \*Controllare le sedie regolarmente.





#### **Condizioni per il deposito:**

\*Il tessuto va riposto completamente asciutto in un luogo asciutto e pulito per evitare i rischi di muffa.





#### **Cautela causa rischio di tagli o pizzicamenti durante l'assemblaggio.**

**Il produttore declina ogni responsabilita' in caso di lesioni derivanti da montaggio inaccurato o dalle condizioni metereologiche.**





**BOX-1/4**

NO.	PARTS	QTY
A		2
B		2
C		2
T		2
E ↓ O		1





**BOX-2/4**











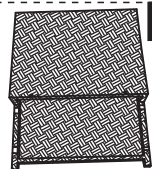
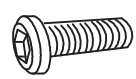

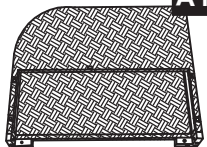
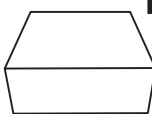
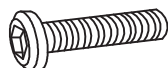
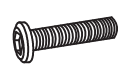

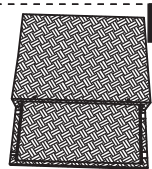

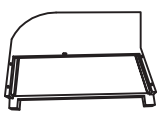



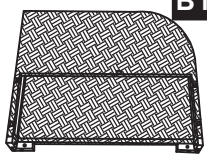



NO.	PARTS	QTY
C1		1
D1		2
E1		1
F1		2
V		3

**BOX-3/4**

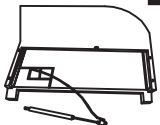
NO.	PARTS	QTY
A1		1
B1		1
D		2
W		3

**BOX-4/4**

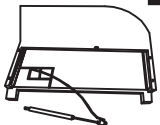
NO.	PARTS	QTY
A2		2
B2		1
U		2
X		2

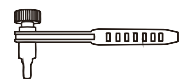
 <b>A x 2</b>	 <b>C 1 x 1</b>	 <b>H x 4</b> M8*40	 <b>O x 2</b>
 <b>A1 x 1</b>	 <b>D x 2</b>	 <b>I x 4</b> M8*65	 <b>S x 2</b> M6*50
 <b>A2 x 2</b>	 <b>D1 x 2</b>	 <b>J x 74</b> M6	 <b>T x 2</b>
 <b>B x 2</b>	 <b>E x 4</b> M6	 <b>K x 36</b>	 <b>U x 2</b>
 <b>B1 x 1</b>	 <b>E1 x 1</b> M8	 <b>L x 16</b>	 <b>V x 3</b>
 <b>B2 x 1</b>	 <b>F x 8</b> M6*50	 <b>L1 x 18</b> M6*55	 <b>W x 3</b>
 <b>C x 2</b>	 <b>F1 x 2</b> M8	 <b>M x 8</b>	 <b>X x 2</b>
 <b>Y x 1</b> M6*60	 <b>G x 10</b>	 <b>N x 2</b>	 <b>Y x 1</b>

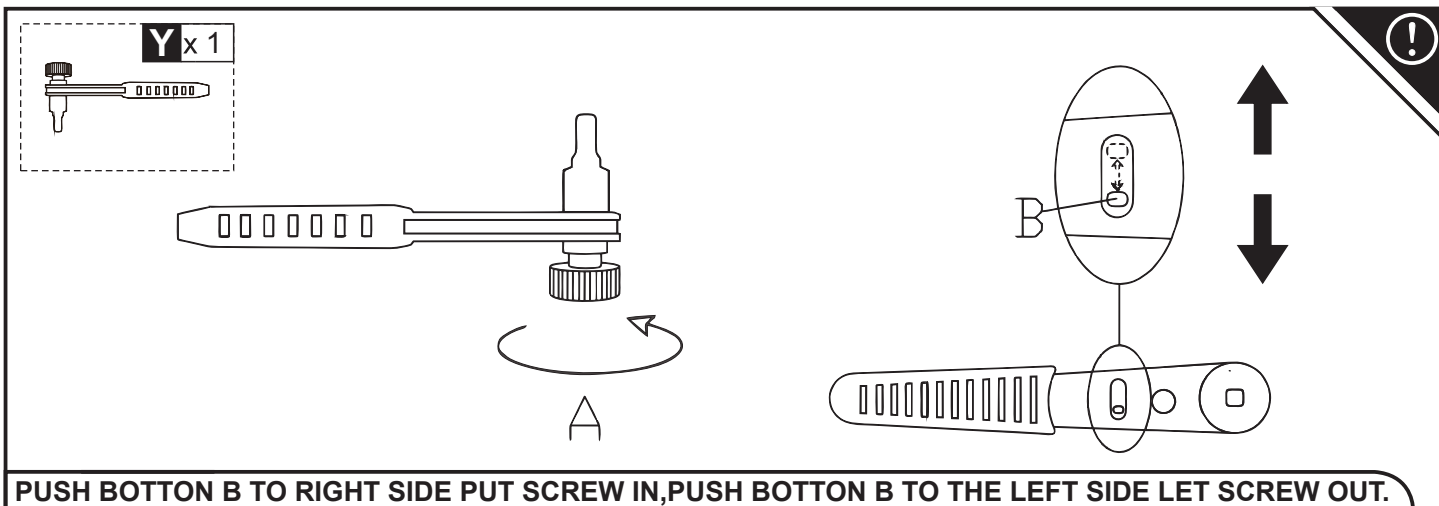

**F x 2**



M6\*50

**G x 1**



M6\*60

**J x 6**



M6

**K x 3**



M6

**J.K**

**B**

**J.K**

**J.G**

**D**

**J.F**

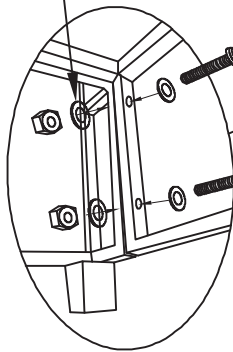

x2

**F x 2**



M6\*50

**G x 1**



M6\*60

**J x 6**



M6

**K x 3**



M6

**J.G**

**J.K**

**C**

**J.K**

**J.F**

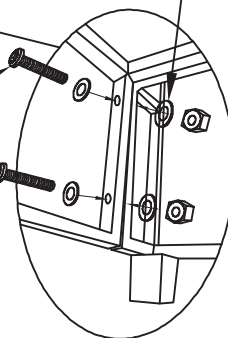
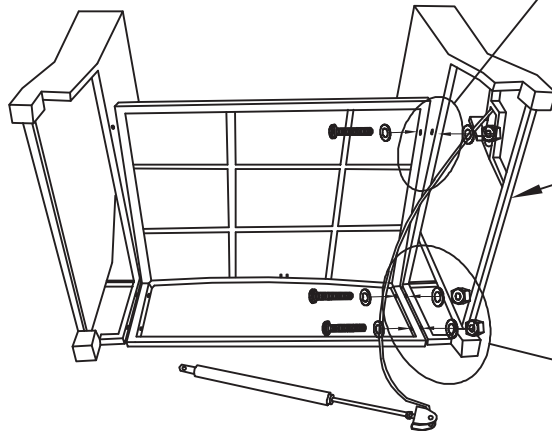

x2

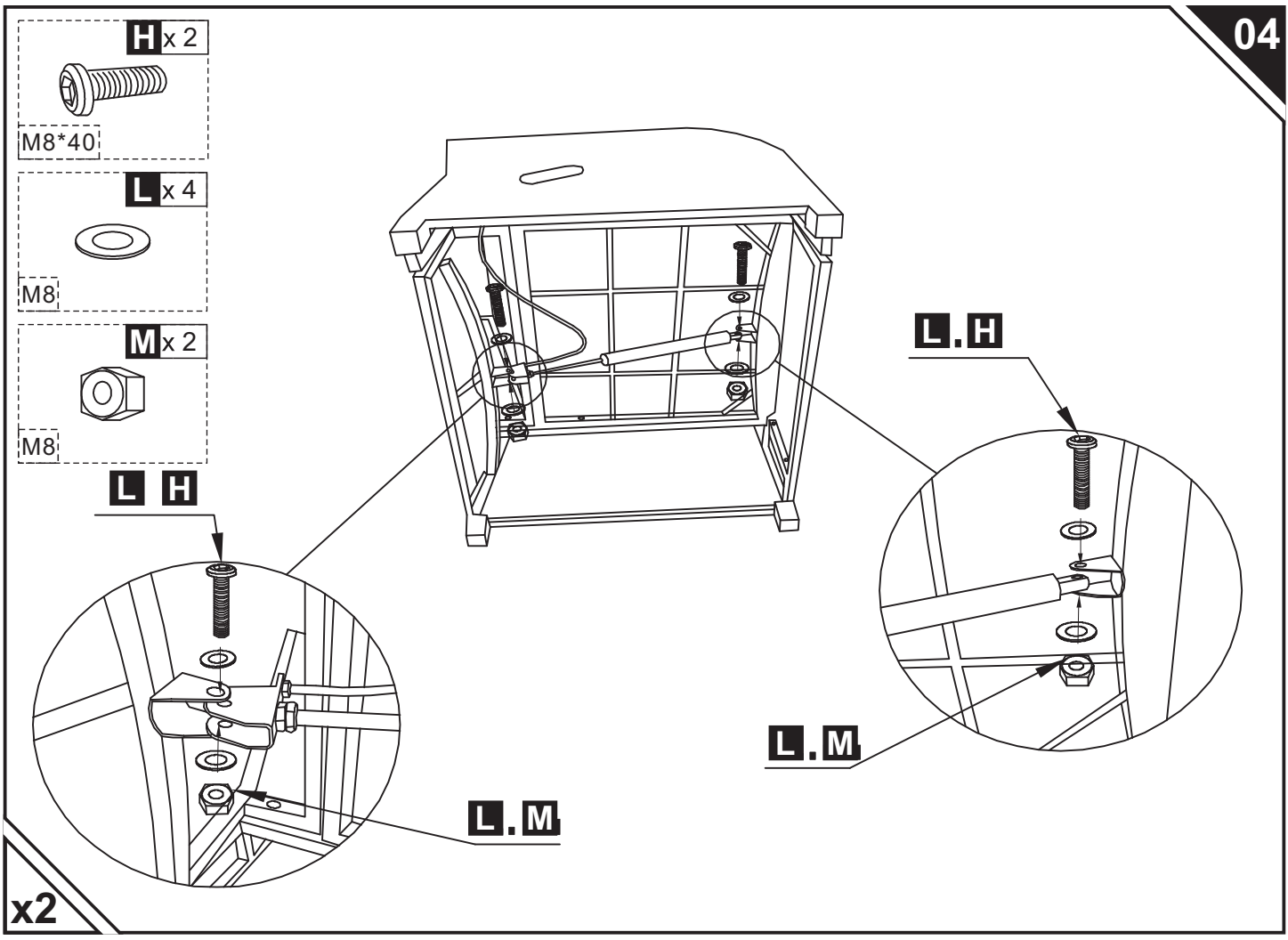
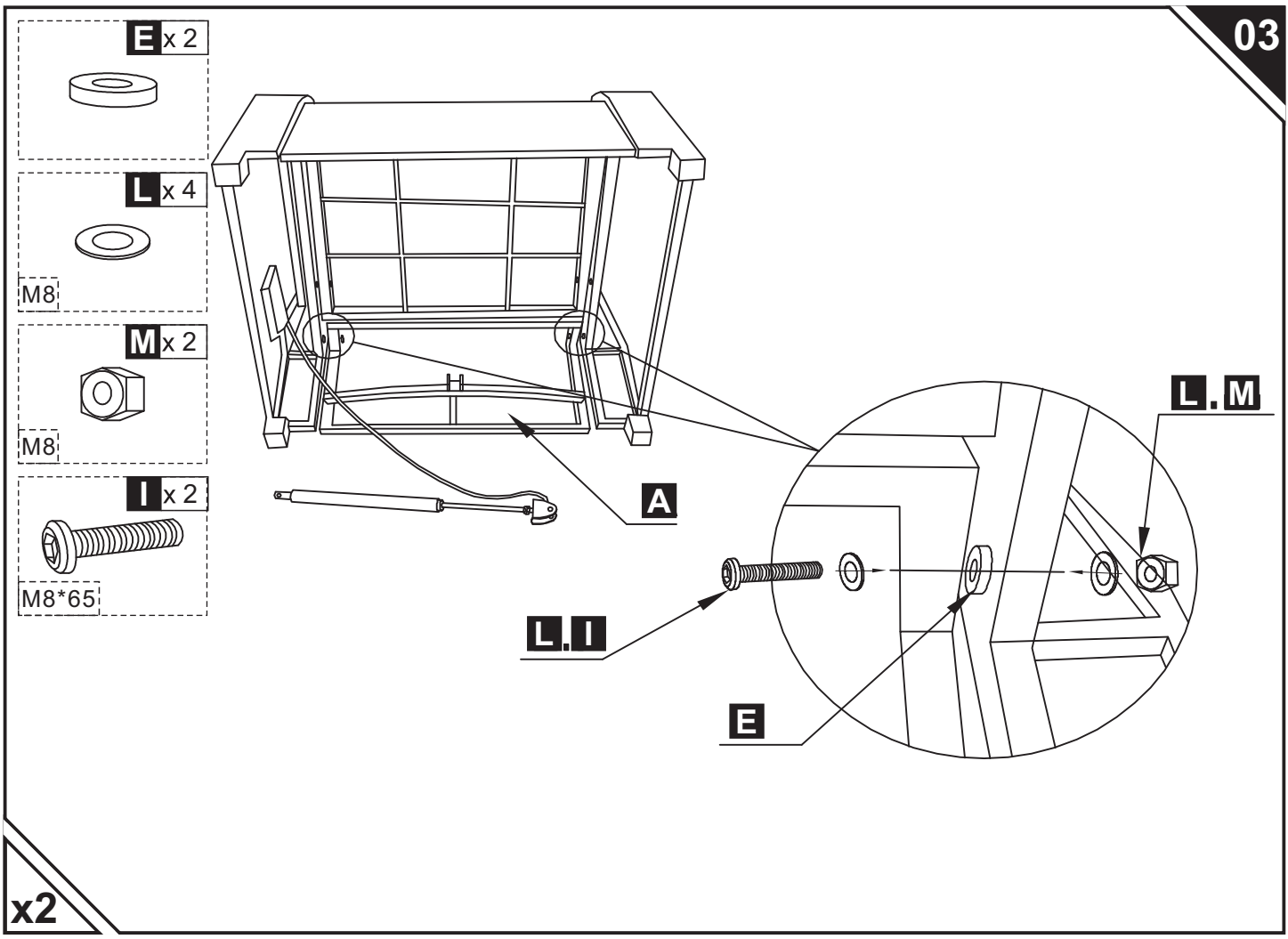

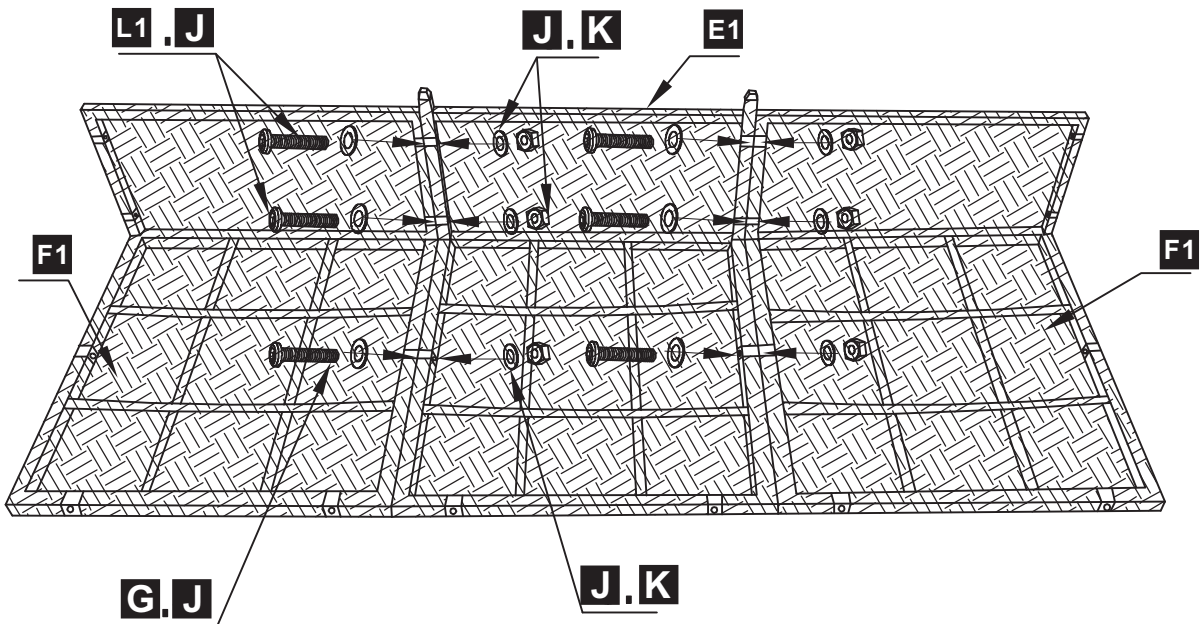
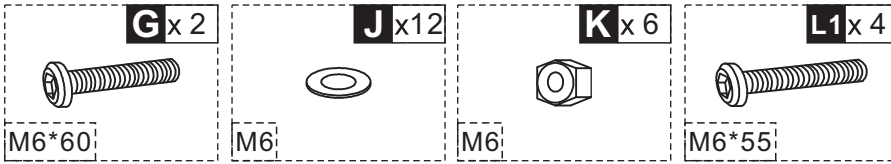
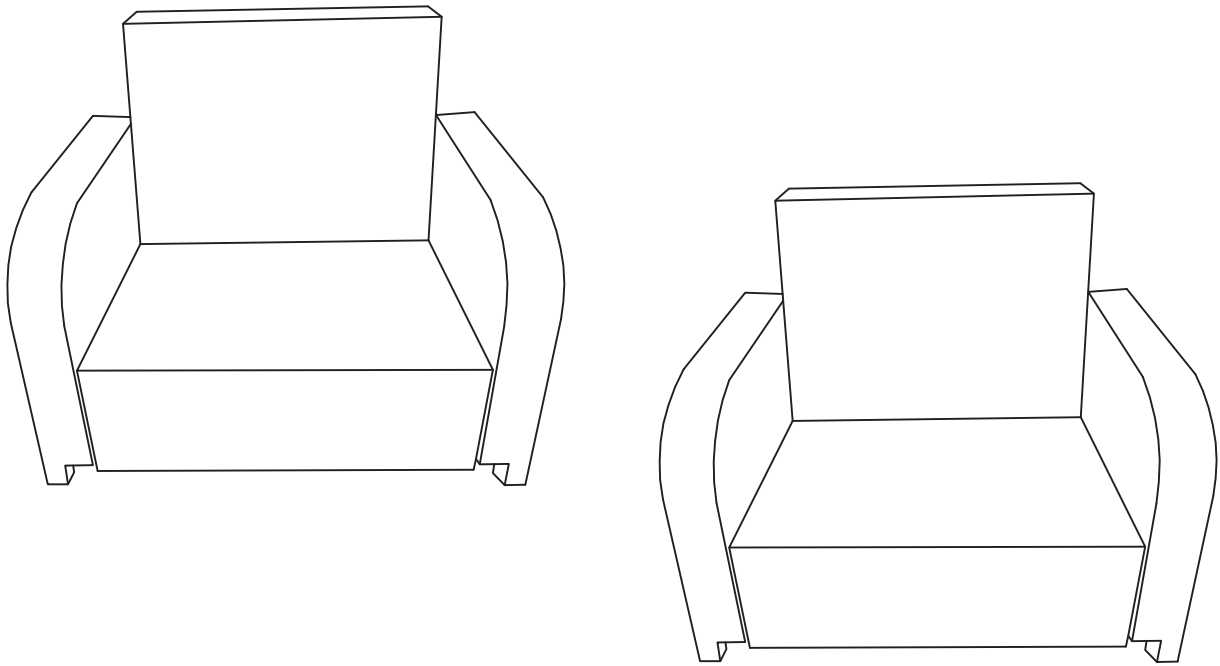

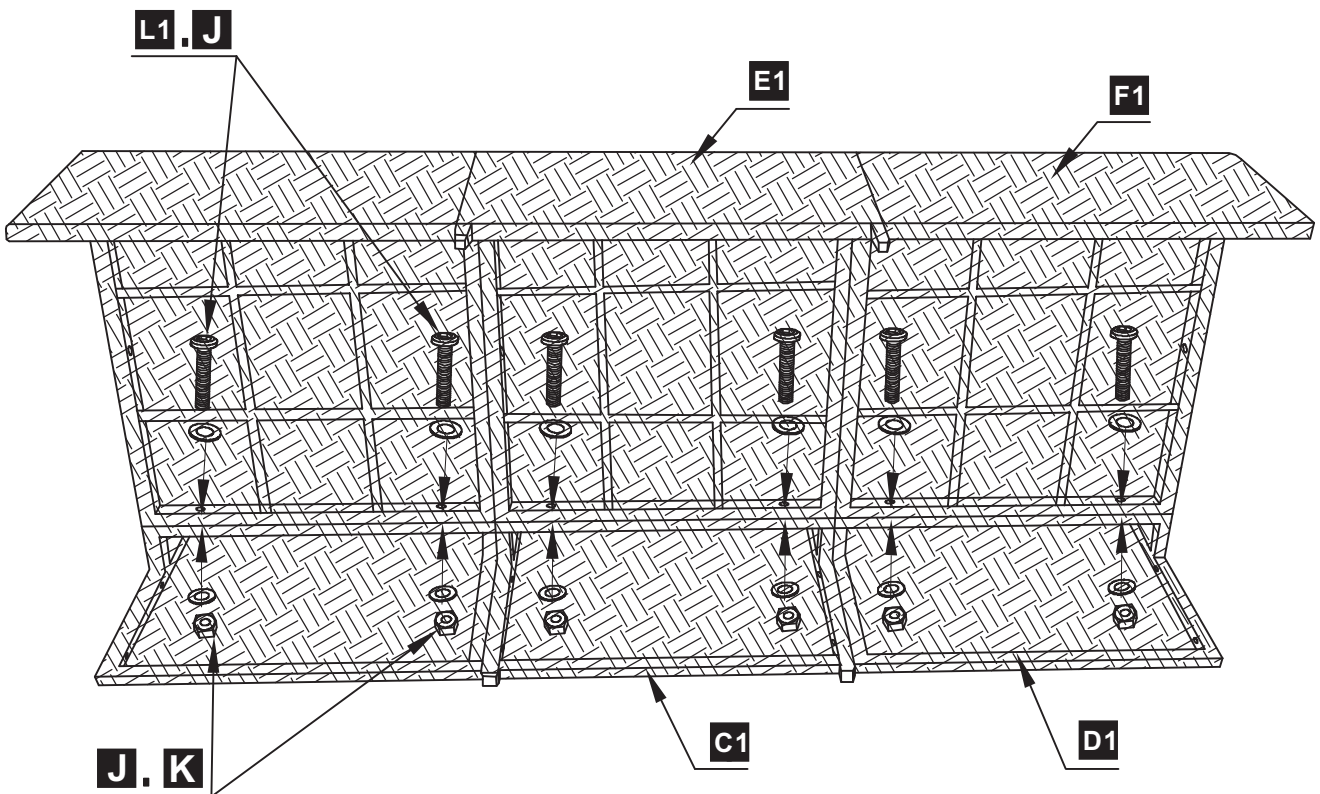
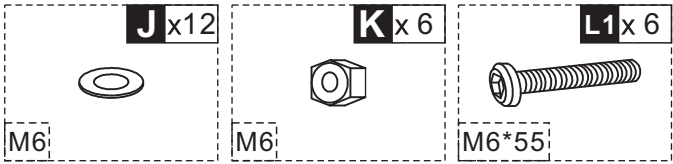
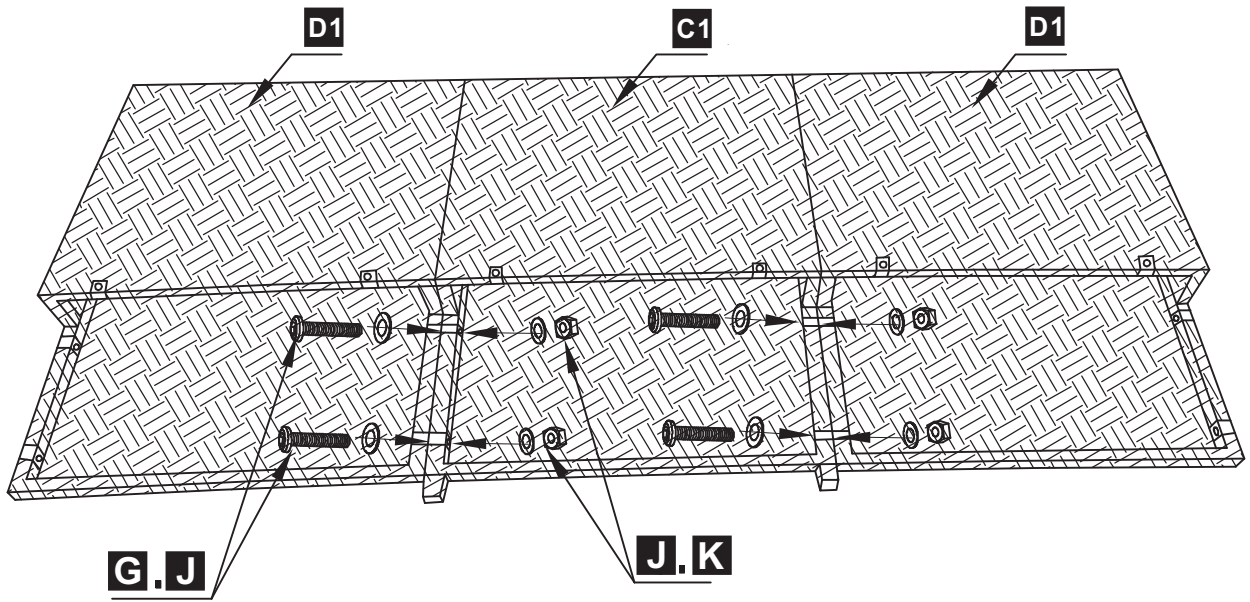
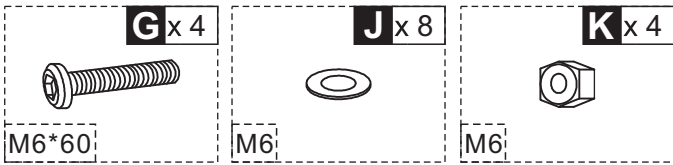

**J** x 18



M6

**K** x 8



M6

**L1** x 8



M6\*55

**S** x 2



M6\*50

