

# HEADBOARD ASSEMBLY INSTRUCTION

( FULL / QN / CK / EK )

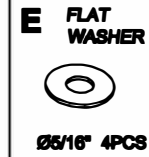

**OPTION 1:**

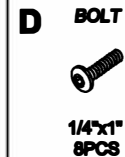
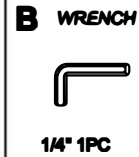
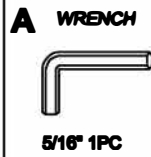
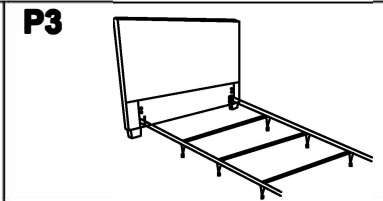
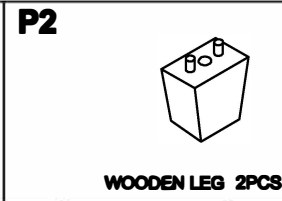
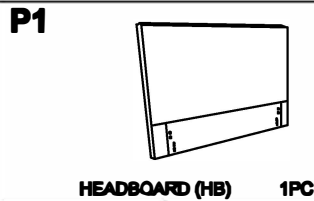
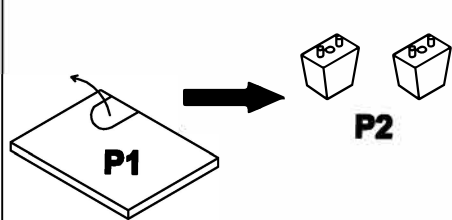

STEP 1: TAKE THE LEGS OUT FROM THE BACK OF HEADBOARD.

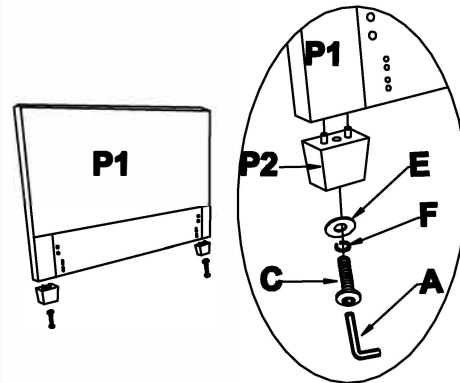

STEP 2: ASSEMBLE THE WOODEN LEGS TO THE BOTTOM OF HEADBOARD.

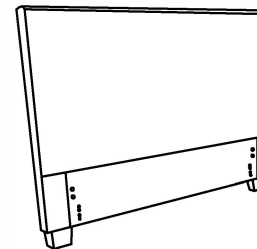

ASSEMBLY COMPLETE.

**INSTRUCTIONS FOR ADJUSTING LEVELERS.**

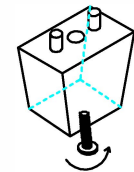

THE LEVELERS ARE LOCATED ON THE UNDERSIDE OF EACH OF THE LEGS (P2). TURN COUNTER-CLOCKWISE TO EXTEND, AND CLOCKWISE TO CONTRACT. ADJUST LEVELERS UNTIL THE LEGS MATCH EACH OTHER IN HEIGHT.

**OPTION 2:**

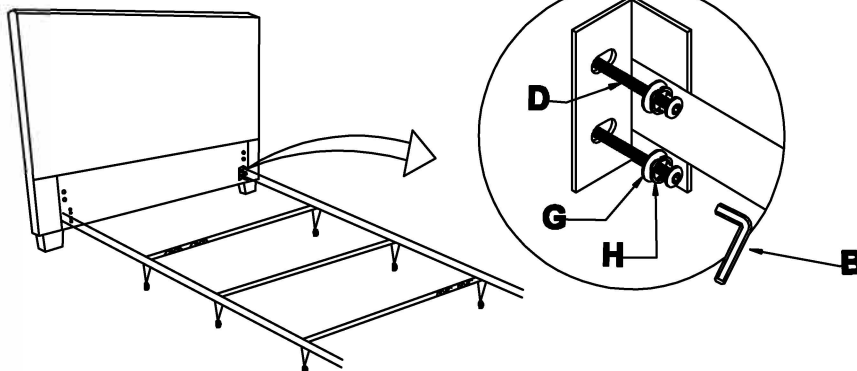

STEP 1: PLACE WASHERS (H&G) THROUGH BOLT (D), AND FASTEN THE METAL BED FRAME TO HEADBOARD.

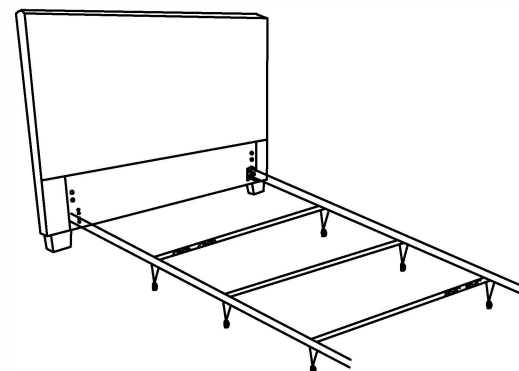

STEP 2: ASSEMBLY IS COMPLETED. SHOWN WITH METAL BED FRAME.