

OWNER'S MANUAL

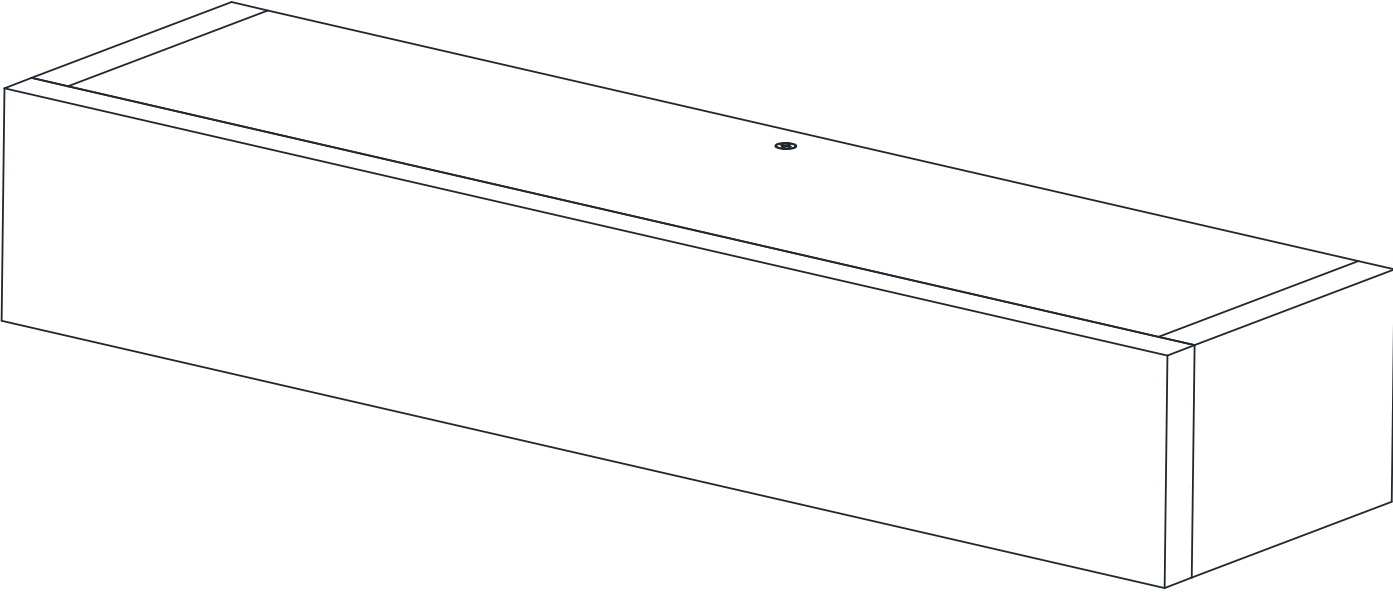

PARTS LIST

A

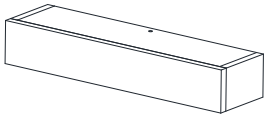

**FLOATING SHELF
(1)**

B



**BRACKET
(1)**

C



**SCREW
(3)**

D

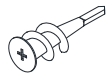

**DRYWALL ANCHOR
(2)**

A

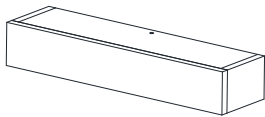

**FLOATING SHELF
(2)**

B



**BRACKET
(2)**

C



**SCREW
(6)**

D

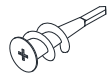

**DRYWALL ANCHOR
(4)**

ASSEMBLY INSTALLATION

STEP 1

Place FLOATING SHELF (A) against wall. With a pencil, mark shelf height at your desired height.

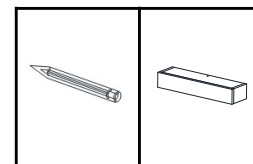

Pencil A (1)

Note: Top of the Bracket will be installed 3/4-inch lower than desired shelf height.

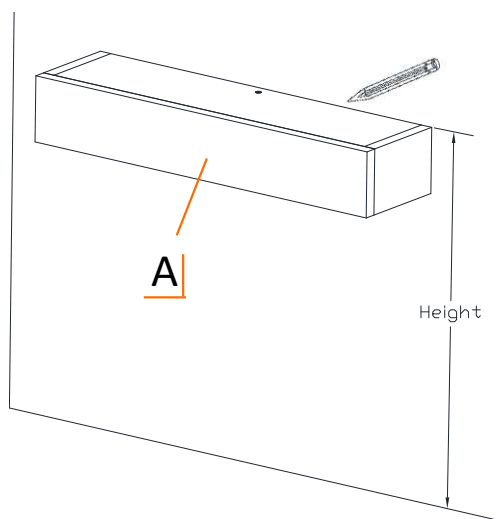

STEP 2

Position BRACKET (B) 3/4-inch lower than desired shelf height marked in STEP 1. Using a level and pencil, ensure BRACKET (B) is level, and mark center of two mounting slots

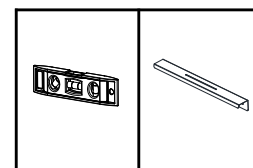

Level B (1)

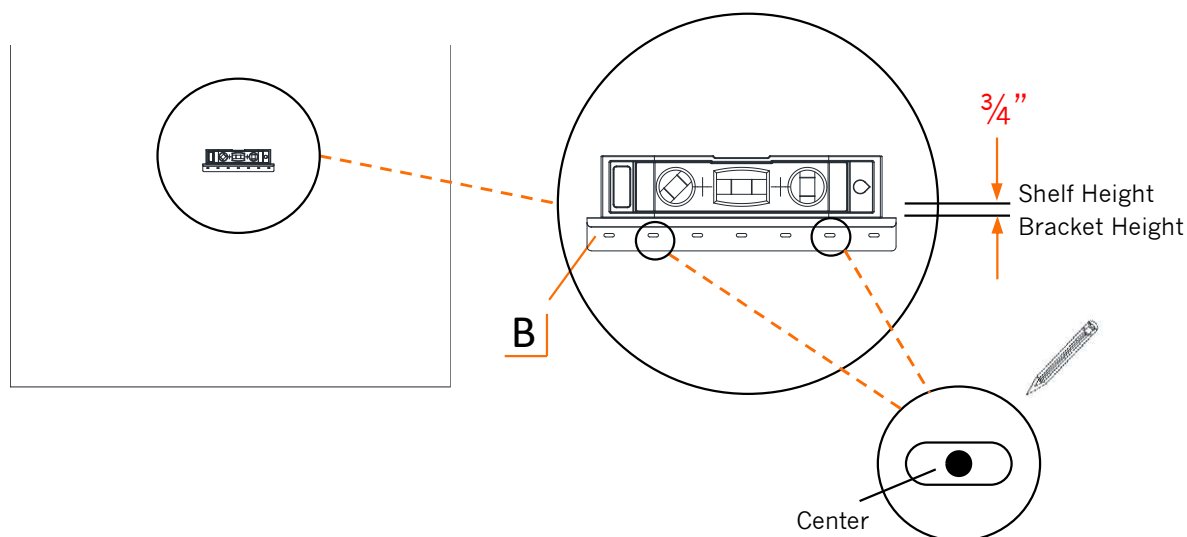

ASSEMBLY INSTALLATION

STEP 3

Set BRACKET (B) aside. Using 1/4-inch Drill Bit, drill 2 pilot holes into wall through marked center of slots.

Screw (2) DRYWALL ANCHORS (D) into pilot holes with a screwdriver.

Note: If mounting onto a surface other than drywall, you may need to purchase specialty screws and anchors for that type of surface. If unsure, please consult a local professional for proper tools and hardware needed.

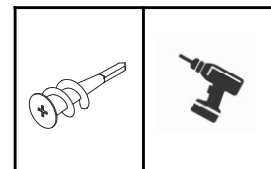

D (2)

Drill

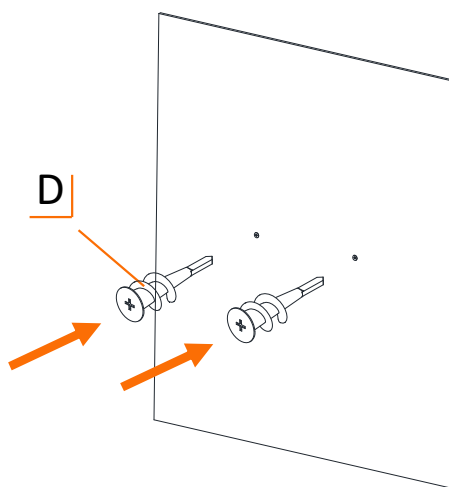

STEP 4

Attach BRACKET (B) to wall using (2) SCREWS (C).

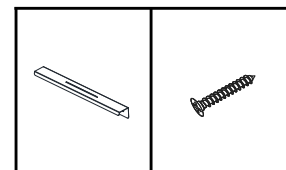

B (1)

C (2)

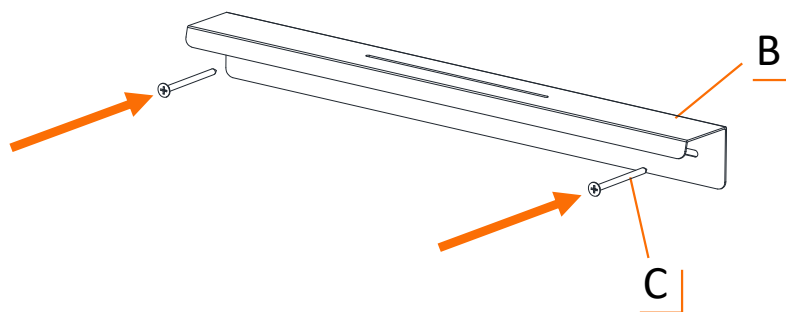

ASSEMBLY INSTALLATION

STEP 5

Slide FLOATING SHELF (A) securely onto BRACKET (B).

Attach FLOATING SHELF (A) to BRACKET (B) using SCREW (C). Fasten SCREW (C) at a slight angle into predrilled hole on top of FLOATING SHELF (A) with a screwdriver.

Note: Insert screw at a slight angle into shelf to better pull shelf tight against wall.

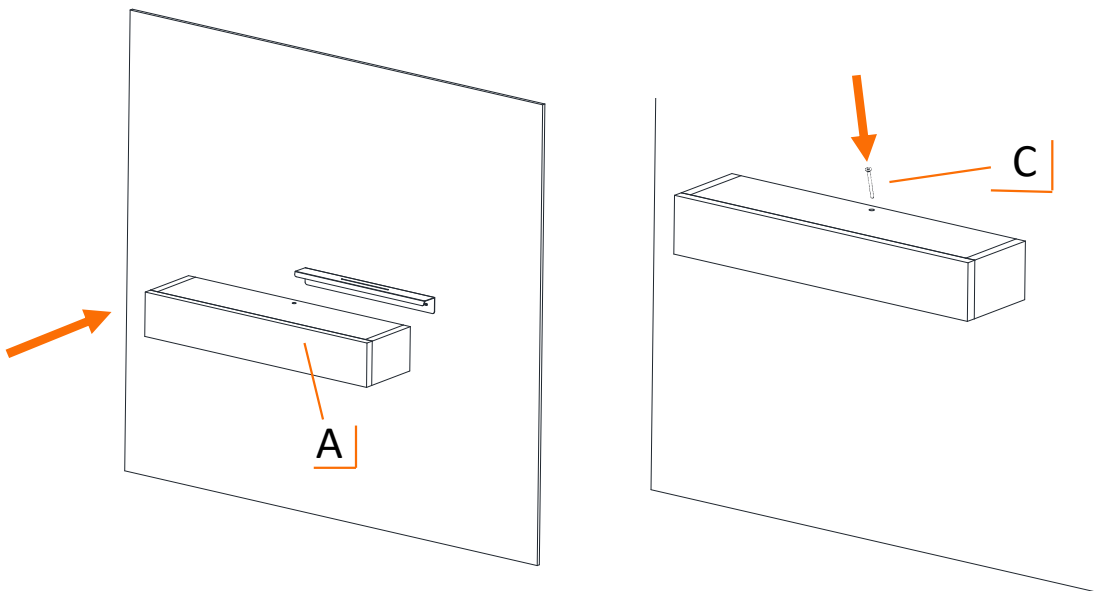
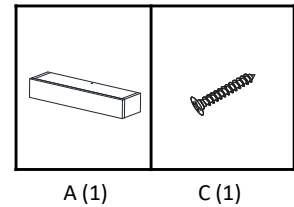

STEP 6

If purchased 2-pack, repeat steps to install second Floating Shelf.

WARNINGS

1. **Read and understand all instructions.** Failure to follow all instructions may result in injury and/or damage.
2. **The warnings, cautions, and instructions discussed in this manual cannot cover all possible conditions or situations that may occur.** The user must always be aware of their environment and ensure that they use the product in a safe and responsible manner.
3. **Do NOT modify the product in any way.** Unauthorized modification may impair the function and/or safety of the product and may affect the life of the product. Any modifications will void warranty.
4. **Check for damaged parts.** Before using this product, carefully check that all parts are in good condition, and that the product will operate properly and perform its intended function. Replace damaged or worn parts and never use this product with a damaged part.
5. **Do NOT overload the product.**

Total weight capacity	15 lb
-----------------------	-------

CARE AND MAINTENANCE

- Avoid harsh, abrasive cleaners, and other corrosive chemicals.
- Do not use scouring pad for cleaning.
- Clean with damp cloth and/or mild dish soap.
- Dry completely with dry sponge or cloth.

1 YEAR LIMITED WARRANTY

FARMHOUSE FLOATING SHELF Model # MFFLT24-SW / MFFLT24-SW-SET2

We warrant to the original consumer purchaser (“Purchaser”) that the products (each a “Product”) shall be free from defects in workmanship and materials for a period of one (1) year from the date of original purchase. Our obligation under this warranty shall be limited to repair or replacement of, or adequate compensation for the Product which shall not be greater than the amount of the purchase price of the Product, during the warranty period. Repair or replacement of the Product will be performed within a reasonable time after notice of the defect has been provided to us by the Purchaser. All replaced parts and Products become the property of us and must be returned to us.

This warranty excludes normal wear and tear of the Product and its parts or components, and damage arising from any of the following: negligent use or misuse of the Product, use contrary to this User’s Manual, or alteration by anyone other than us. The warranty period of one (1) year shall not be extended or renewed by the repair or replacement of, or compensation for, the Product. Any warranty implied by applicable law is limited in duration to one year from the date of purchase and is subject to the same conditions and limitations as is provided for our express warranty.

No warranty or guarantee given by any person, firm, or corporation other than us with respect to the Product shall be binding on us.

LIMITATION OF REMEDIES AND LIABILITY

We (our employees, officers, members, managers, affiliates and assigns) shall not be liable for any incidental, consequential, special, indirect, remote, special or punitive damages for breach of any warranty, express or implied, including, but not limited to, lost profits, lost savings, loss of anticipated benefits and attorneys’ fees, which arise out of the purchase, use or inability to use the Product, whether arising out of contract, negligence, strict tort, product liability, or any other legal theory on which a claim is based. As noted above, to the extent damages are allowed by our express warranty or by applicable law, those damages may not exceed the purchase price paid for the Product. Without limiting the foregoing, Purchaser assumes all risk and liability for loss, damage, or injury to Purchaser and Purchaser’s property and to others and their property arising out of the use, misuse, or inability to use the Product. This limited warranty shall not extend to anyone other than the original purchaser of the Product, is nontransferable, and states your exclusive remedy.

Some States do not allow limitations on how long an implied warranty lasts, so the above limitation may not apply to you. Some States do not allow the exclusion or limitation of incidental, consequential, special, or punitive damages, so the above limitation or exclusion may not apply to you. This warranty gives you specific legal rights, and you may have other rights which vary from State to State.