

ASSEMBLY INSTRUCTION

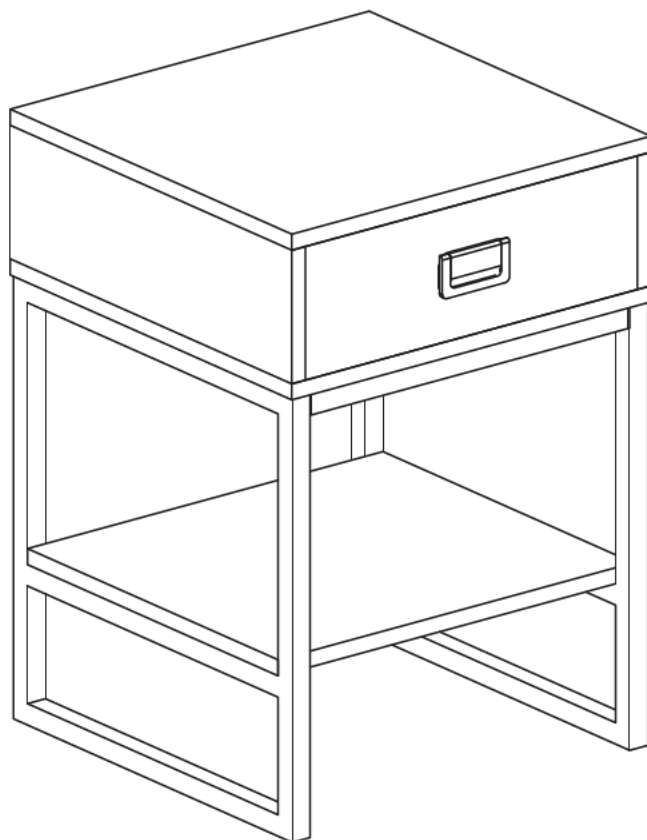

Assembly Instructions

We have designed our furniture with you, the customer in mind. Our clear, easy to follow step by step instructions will guide you through the project from start to finish. Feel confident that this will be a fun and rewarding project. The final product will be a quality piece of furniture that will go together smoothly and give enjoyment.

Care and Clean

1. Place out of direct sunlight so the color remains fresh and crisp .
2. Dust or wipe clean with a cloth dampened with water . Be sure not to leave water spots on the surface . These water spots will dry and could possibly leave permanent marks.

Thank you for purchasing this quality product. This product has been designed for easy assembly and constructed for durability. All parts were checked prior to packaging to insure quality. Prior to beginning assembly, however, make sure all parts and hardware are included and free of obvious defect. If a part is missing or defective, please contact Melody Maison Ltd customer services department customerservices@melodymaison.co.uk.

ASSEMBLY TOOLS REQUIRED NOT INCLUDED

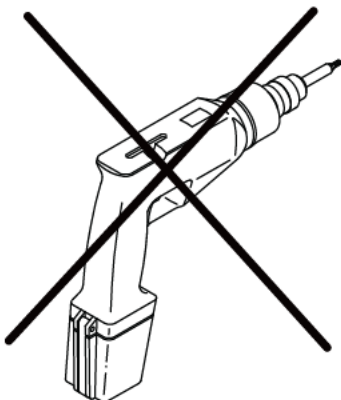
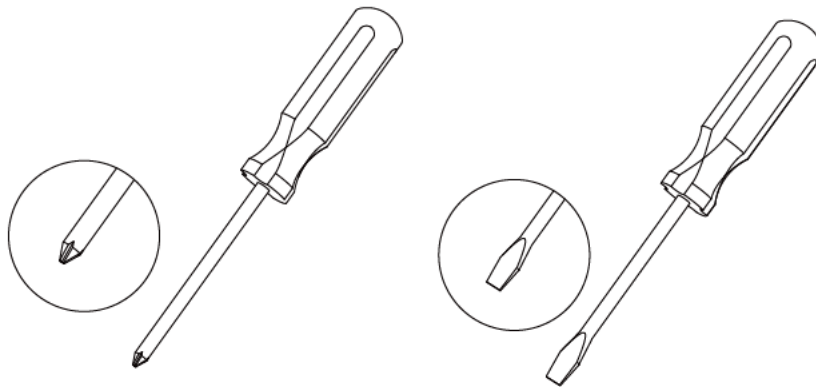

please do not use any power tools in the assembly of this item. Use of power tools may cause damage and void manufacture warranty.

Before assembly

Tips before your start:

- Remove all wrapping material, including staples & packing straps before you start to assemble.
- During assembly please take care not to over-tighten any fittings, as this may damage the product.
- Keep all hardware parts out of reach of children.

QUICKFIT

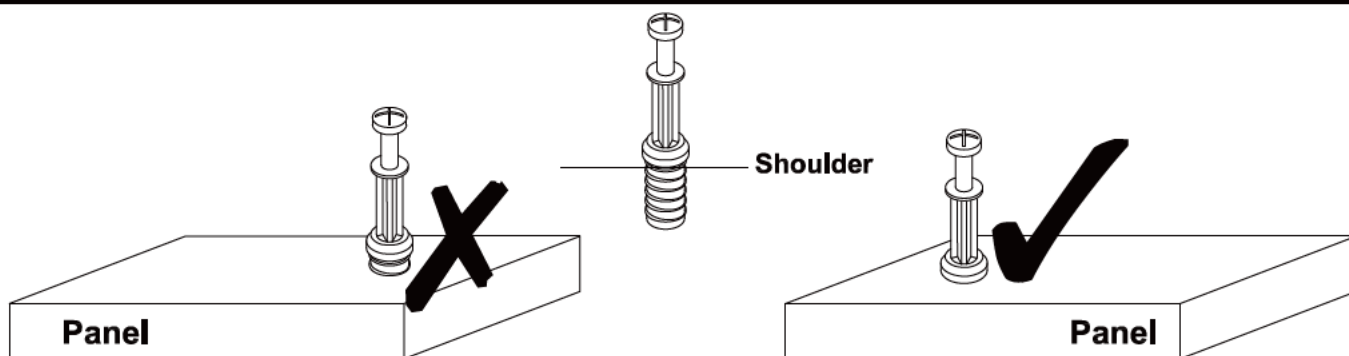

Tighten quickfit until shoulder is flush with panel. Do not overtighten or undertighten.

CAM LOCK

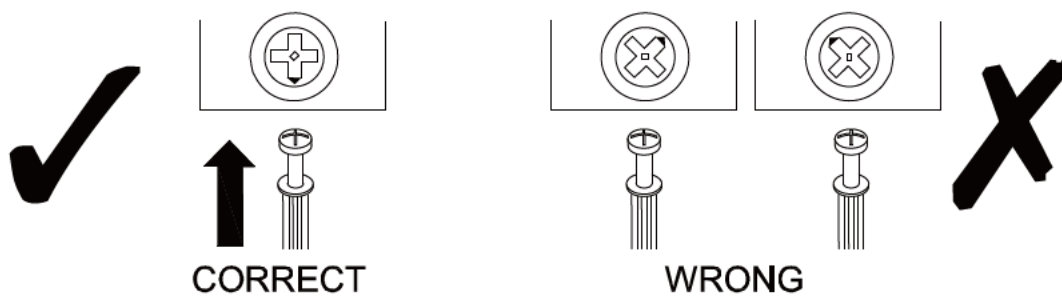

When fitting cam lock, ensure starting position is correct before you insert connecting quickfit.

Quickfit head should be in the centre line of the cam lock when the two panels are joined. Cam lock should be inserted before quickfit.

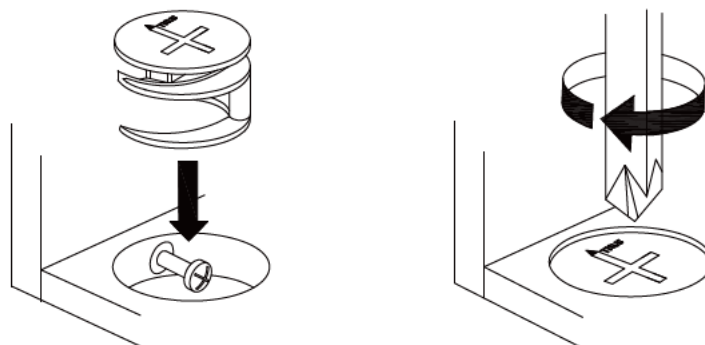

Turn cam lock clockwise to tighten.

Exploded view

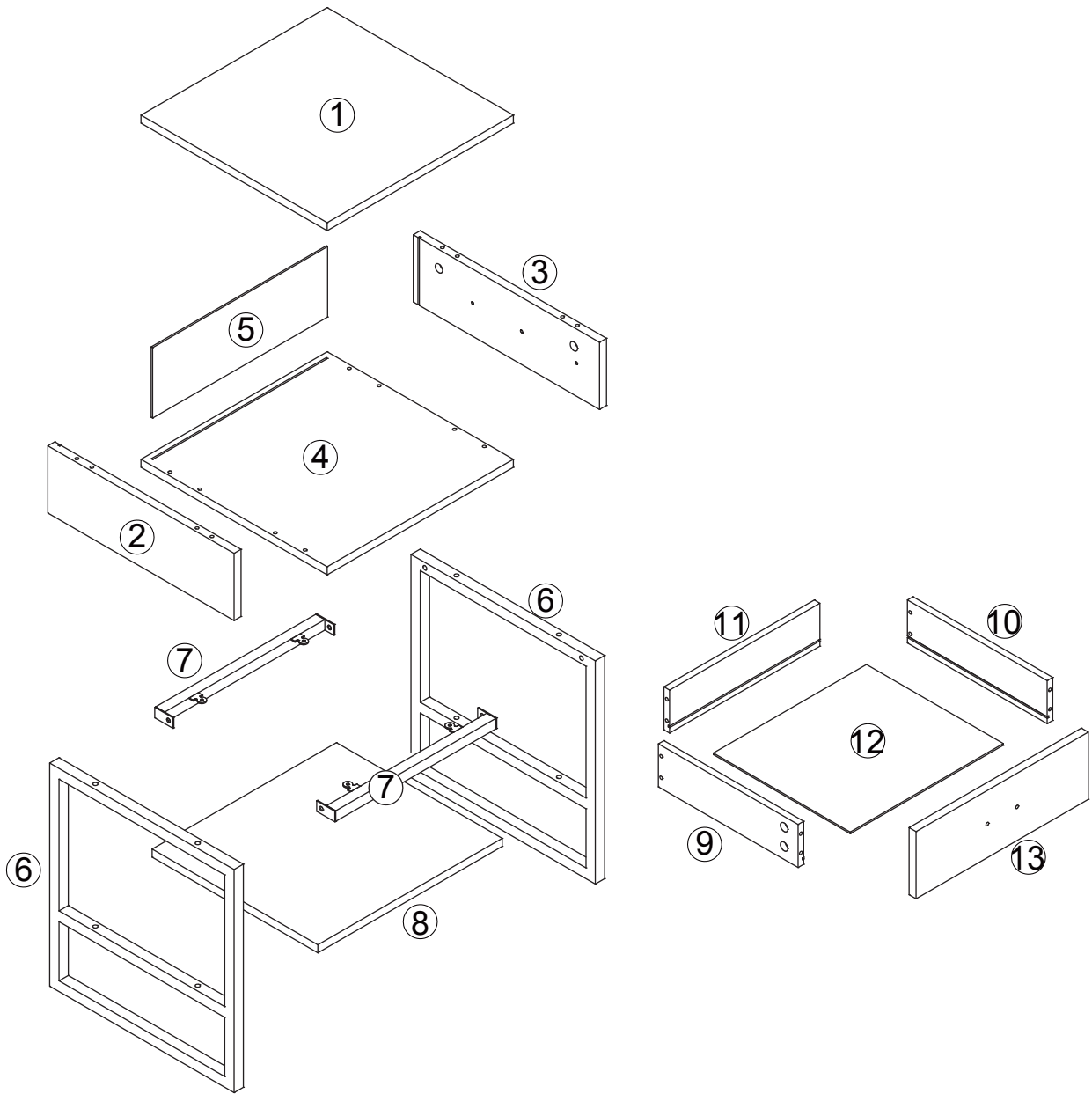





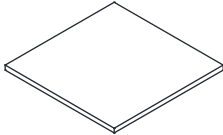
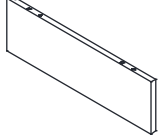
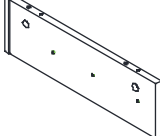
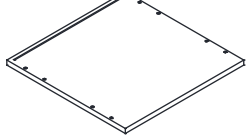
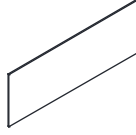
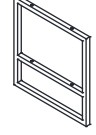
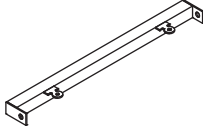
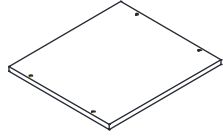
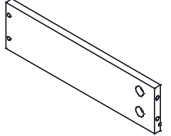
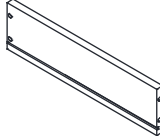
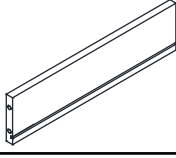
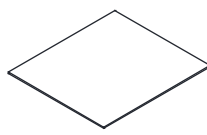
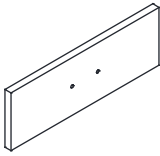



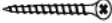
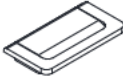

Part list

When unpacking, please be careful not to discard any parts with the packaging.
Before continuing, please make sure you have the following parts:

NO	Description	Qty	Sketch	NO	Description	Qty	Sketch
①	Top Panel	1		②	Left Side Panel	1	
③	Right Side Panel	1		④	Bottom panel	1	
⑤	Back Panel	1		⑥	Leg Frame	2	
⑦	Stretcher	2		⑧	Shelf	1	
⑨	Drawer Left Side Panel	1		⑩	Drawer Right Side Panel	1	
⑪	Drawer Back Panel	1		⑫	Drawer Bottom Panel	1	
⑬	Drawer Front Panel	1					

Hardware list

When unpacking, please be careful not to discard any parts with the packaging. Before continuing, please make sure you have all of the following hardware:

 Cam Bolt Ax8	 Cam Lock Bx8	 Screw Cx14	 Screw Dx8	 Handle Ex1
 Wooden Dowel Fx8	 Bolt Gx4	 Allen Key Hx1	 Screw Ix4	 Bolt Jx8
 Cabinet Slider Kx2	 Drawer Slider Lx2			

(The hardware quantities listed above are required, For proper assembly some extra hardware may have been included.)

Step 1

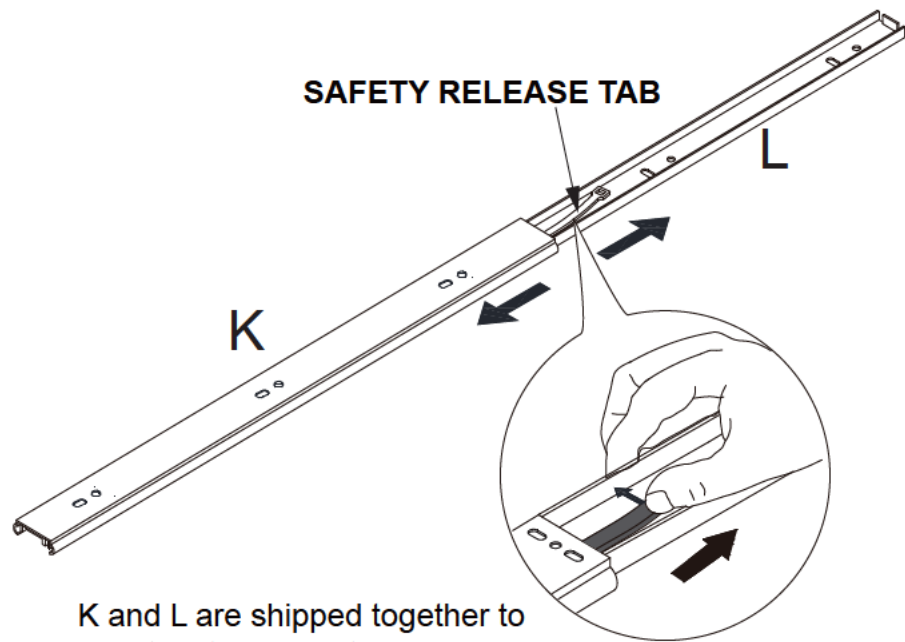

K and L are shipped together to maintain the oil for the ball bearings.
 Note that you need to tip up the safety release tab to take out the L part prior to assembly.

Step 2

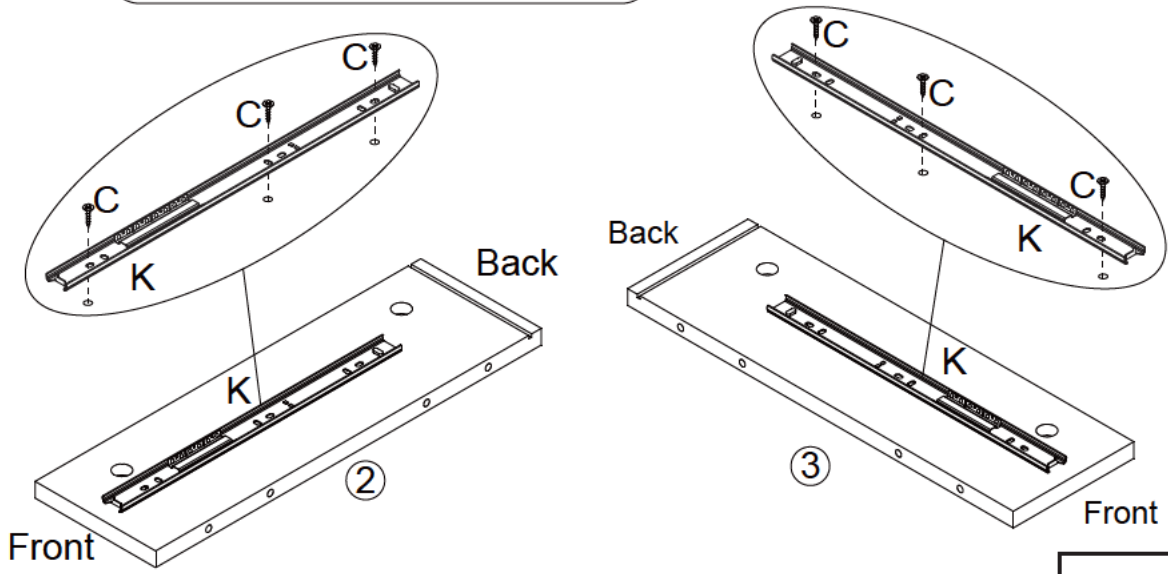
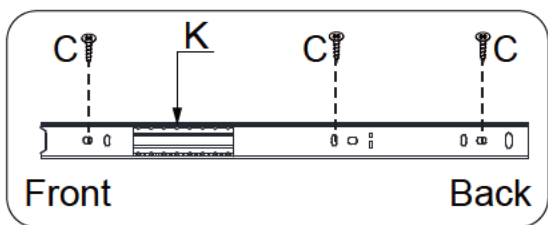

6xC	
2xK	

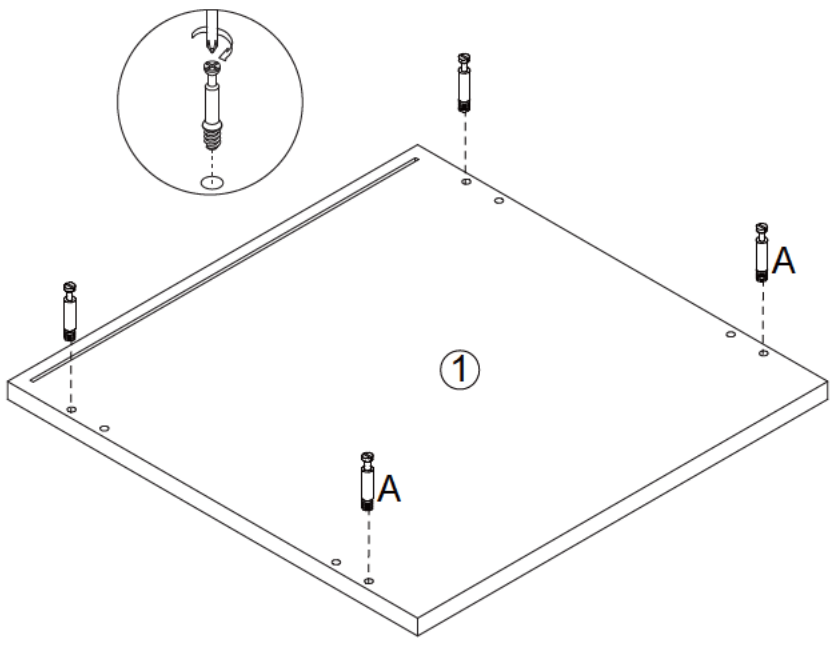

Step 3

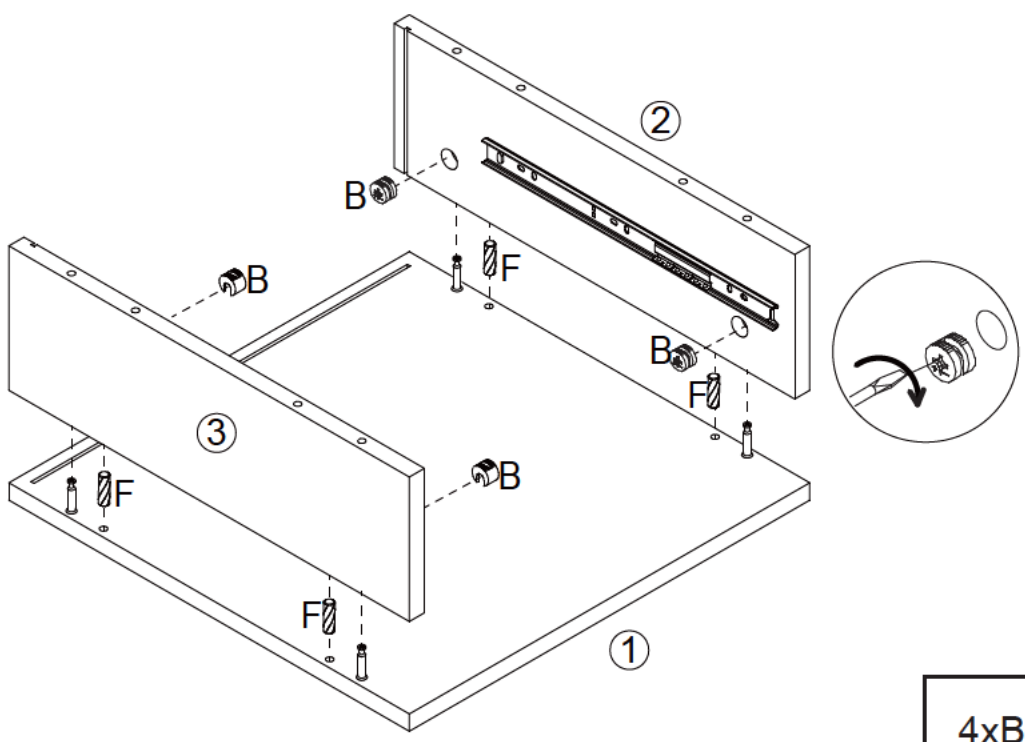

4xA	
-----	--

Step 4



4xB	
4xF	

Step 5

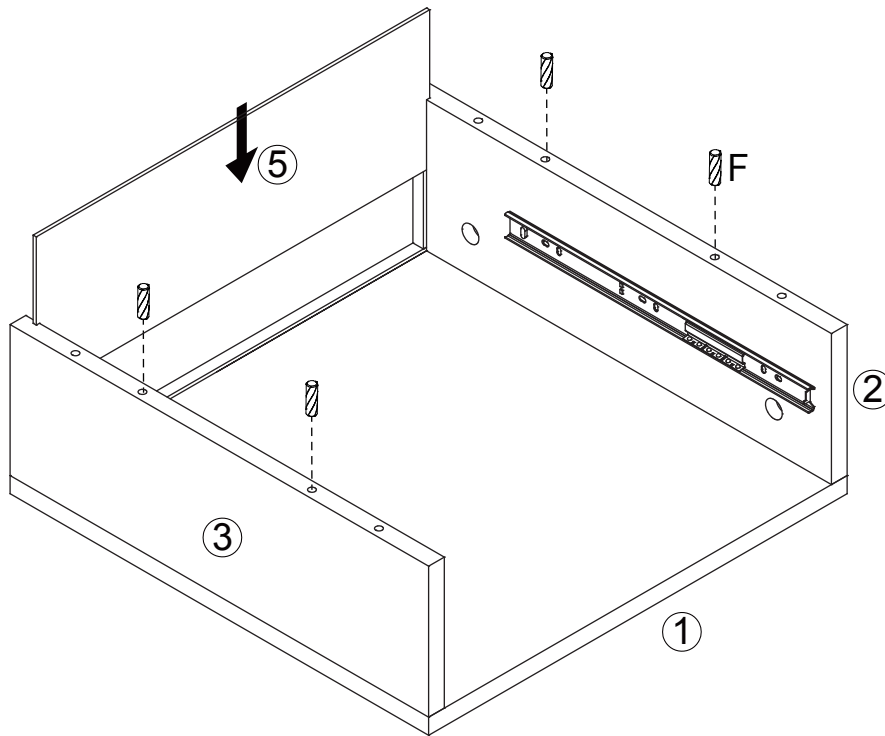

4xF



Step 6

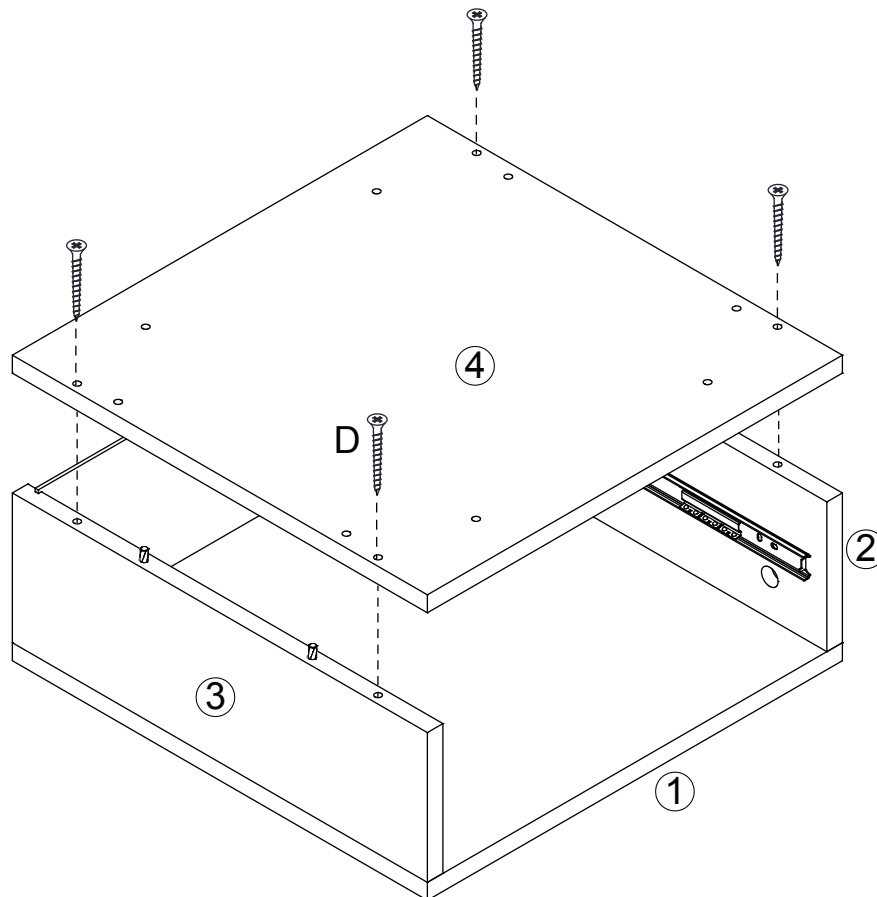

4xD

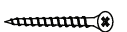

Step 7

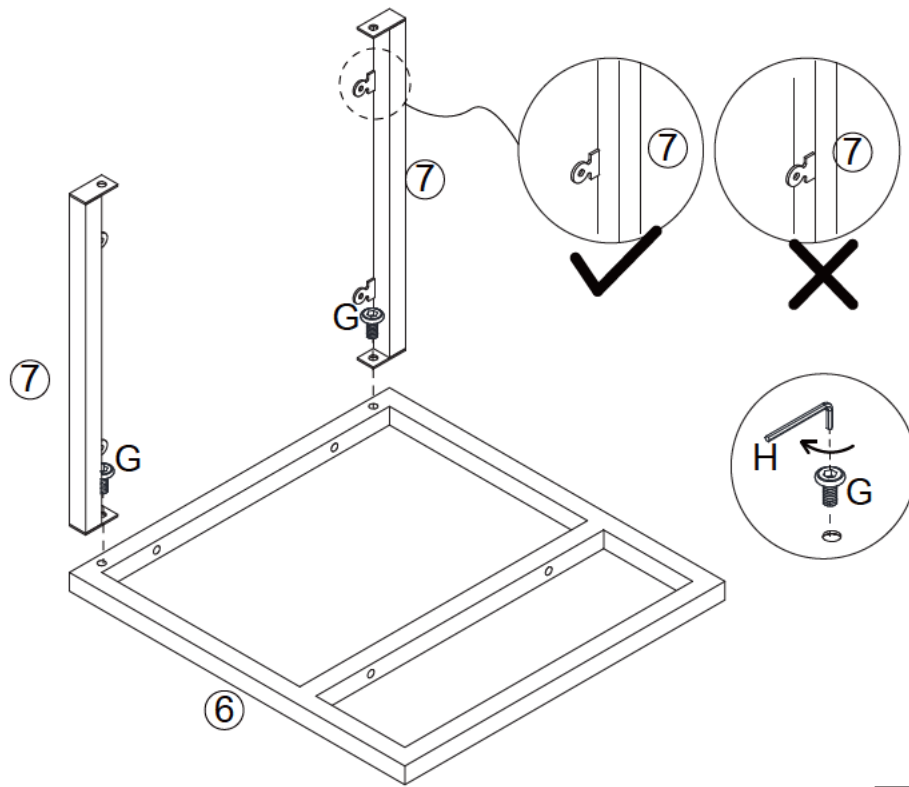

2xG



Step 8

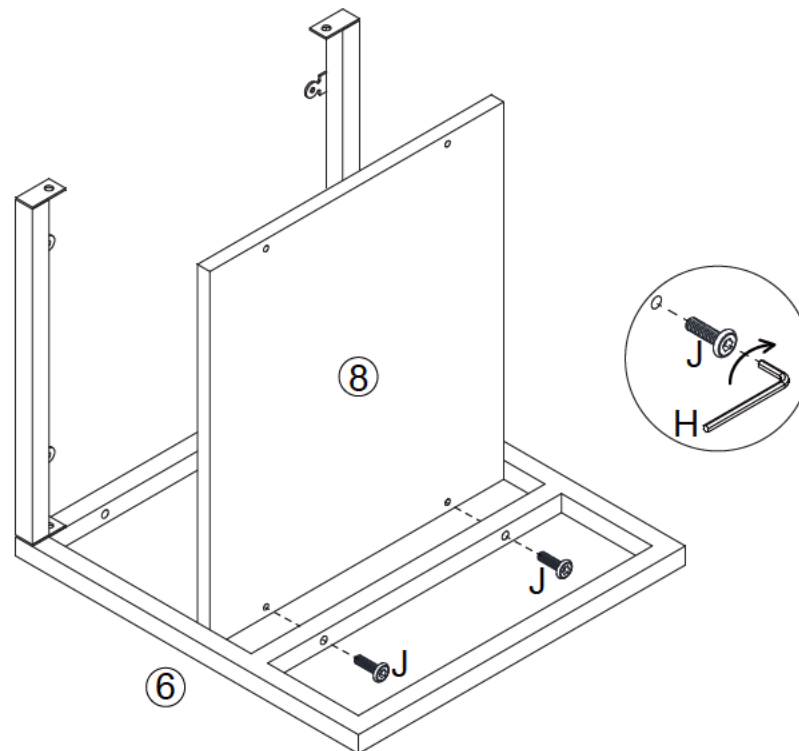

2xJ



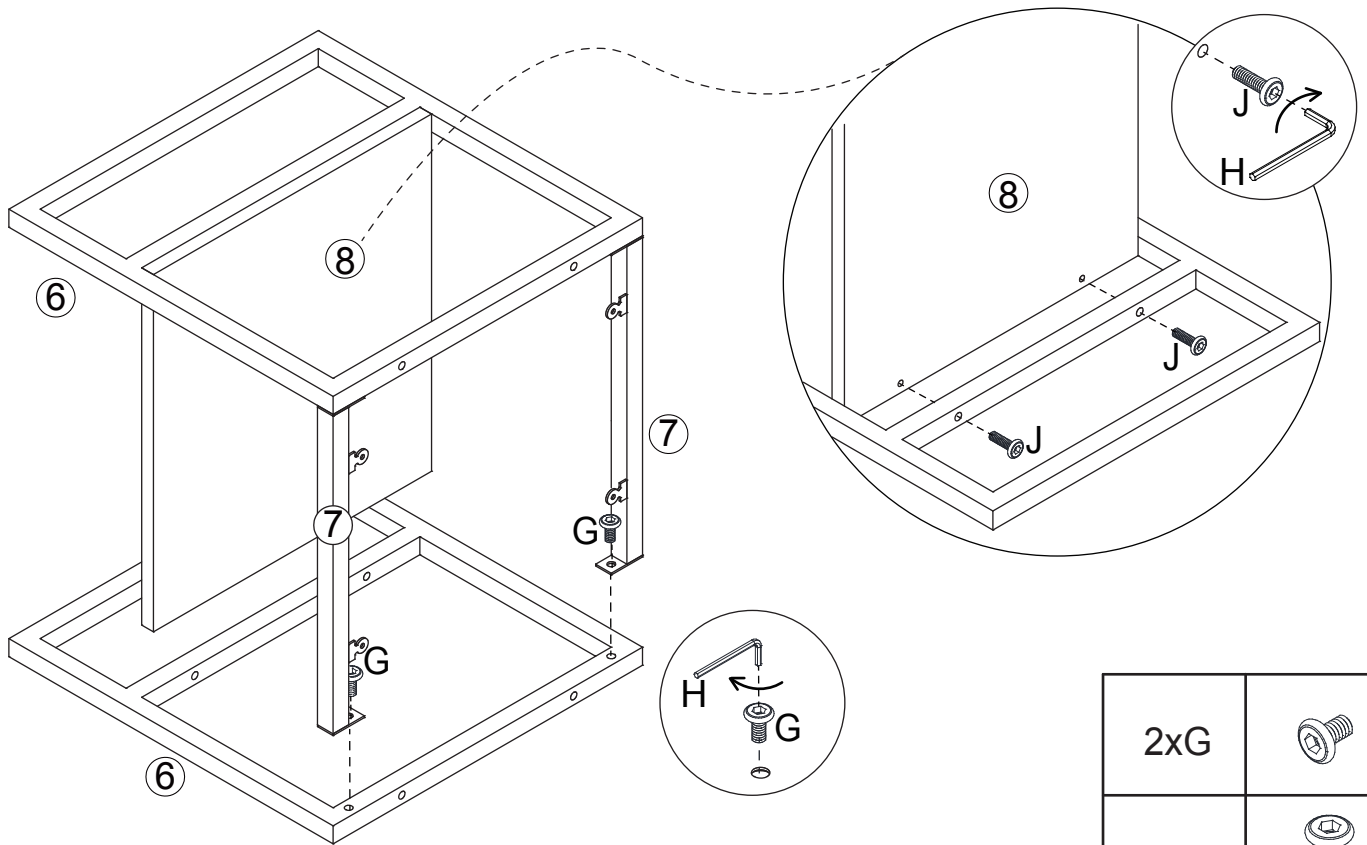

Step 9

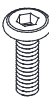

2xG	
2xJ	

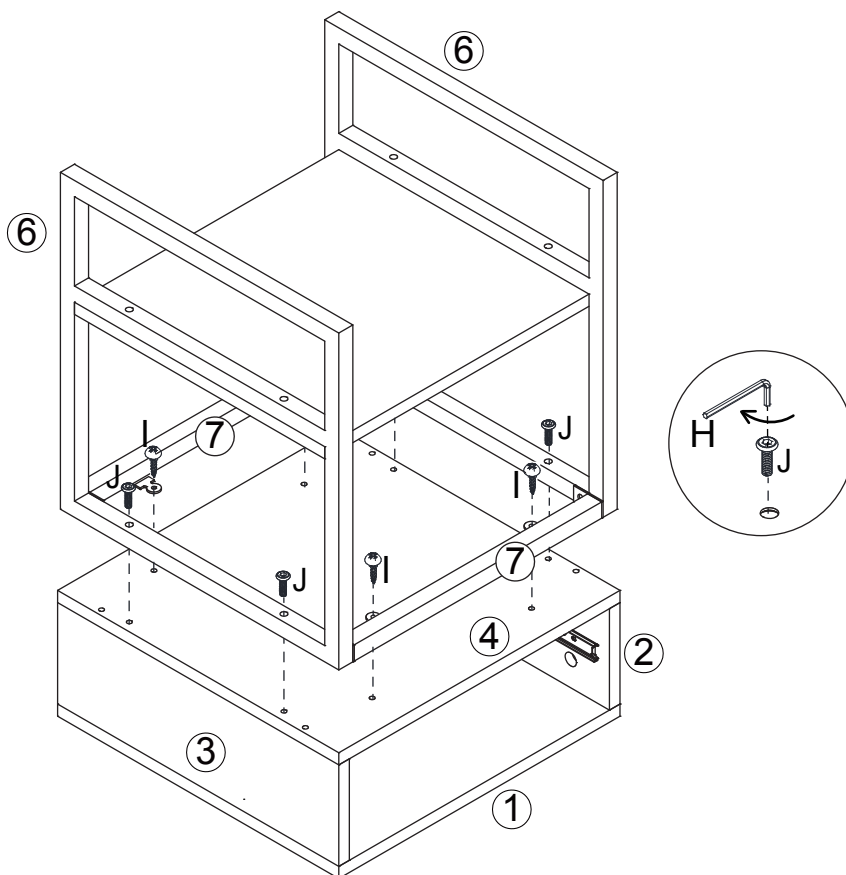

Step 10

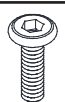

4xI	
4xJ	

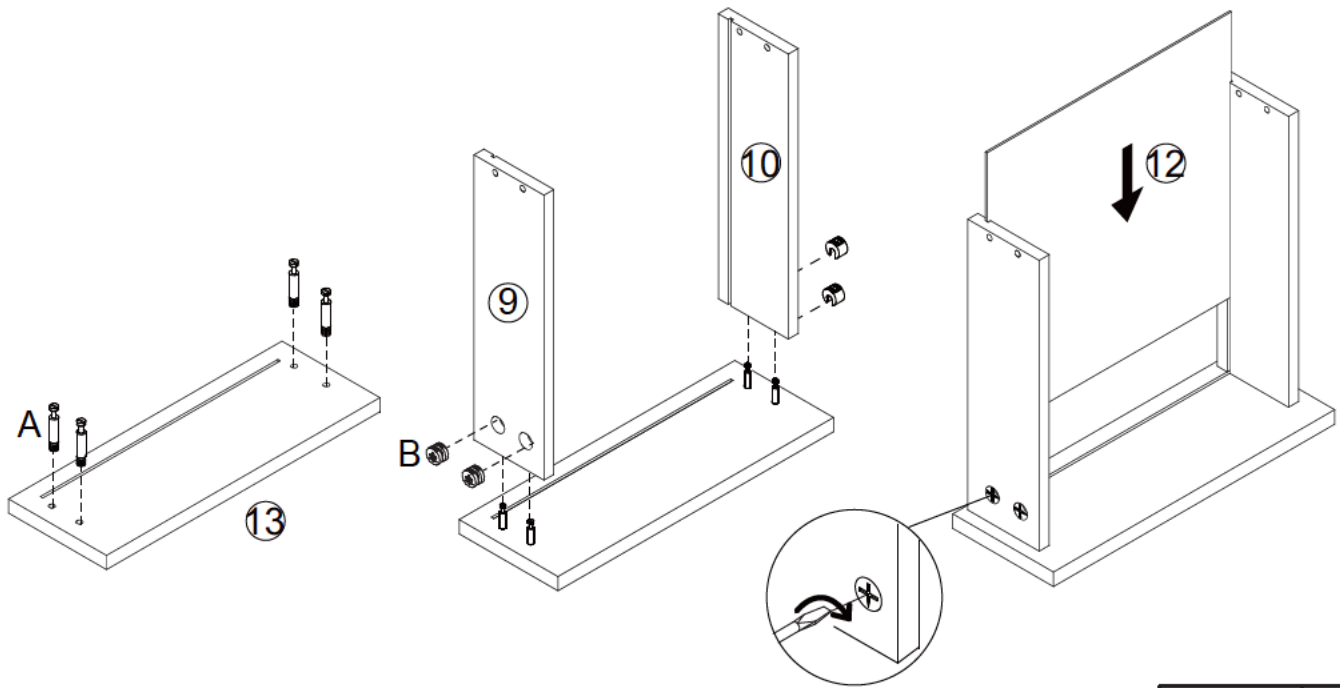
Step 11



4xA	
4xB	

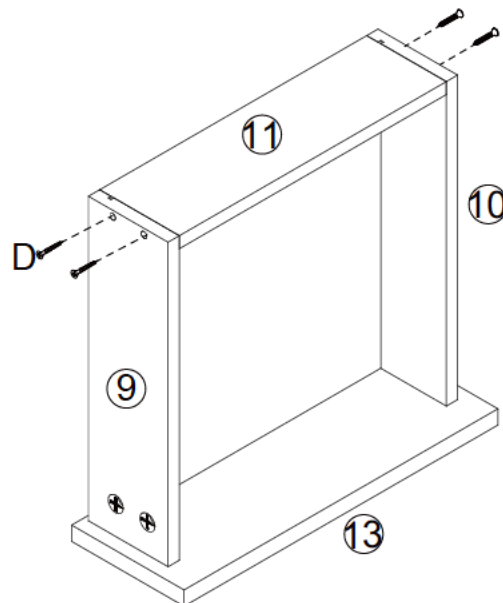

Step 12

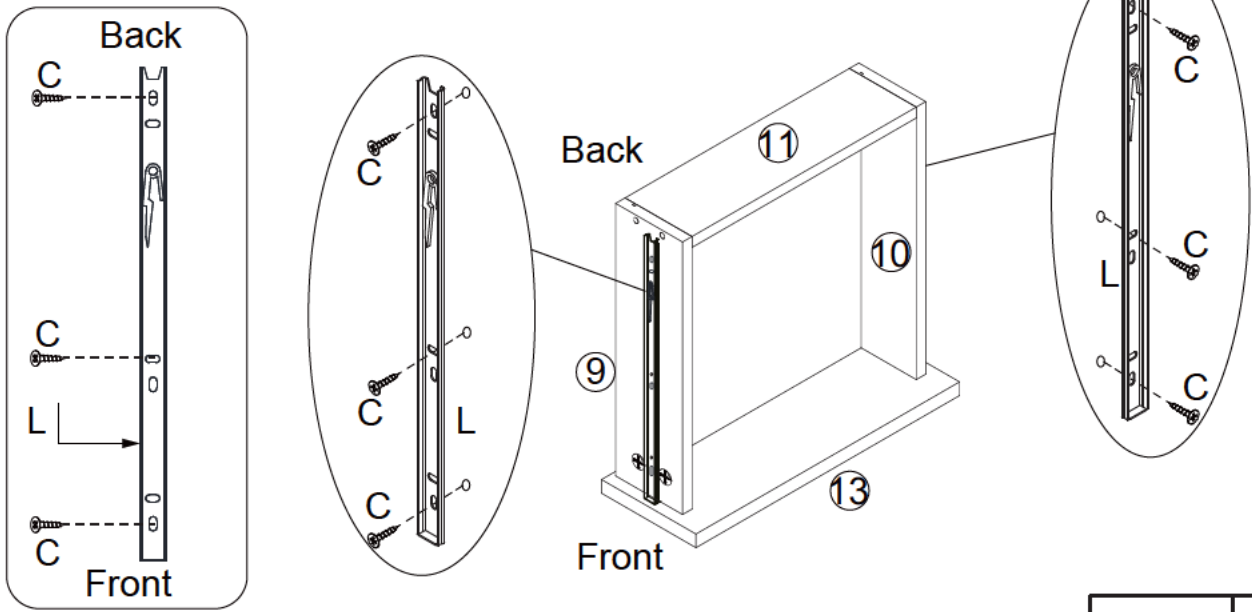

4xD	
-----	---

Step 13



6xC	
2xL	

Step 14

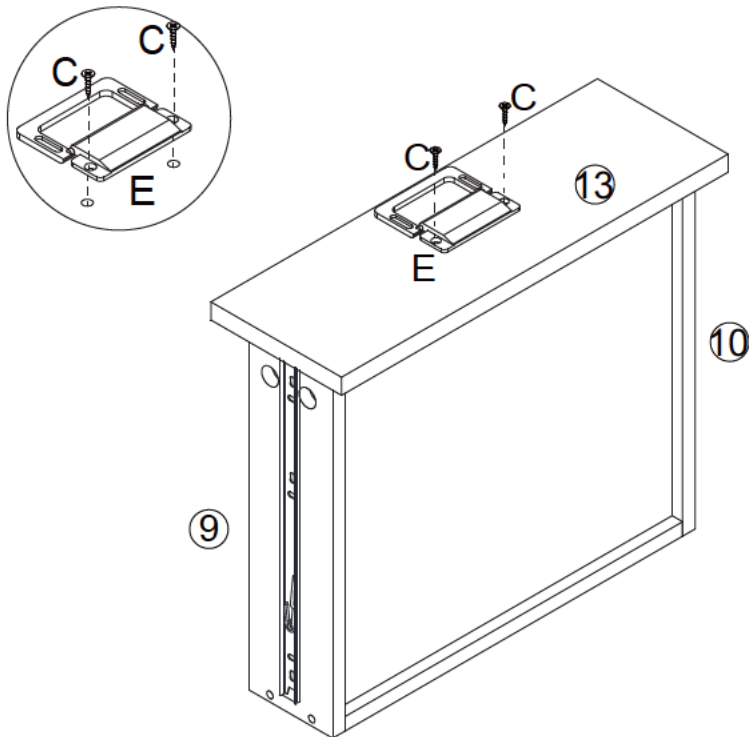

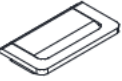
2xC	
1xE	

Step 15

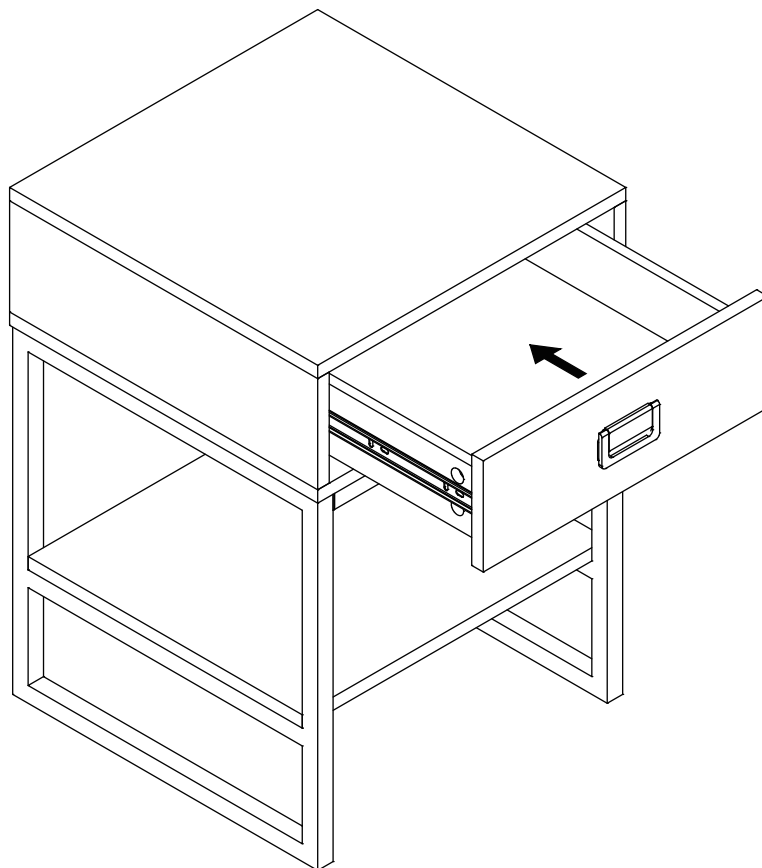

NOTE: Refer to next page for drawer installation guidelines

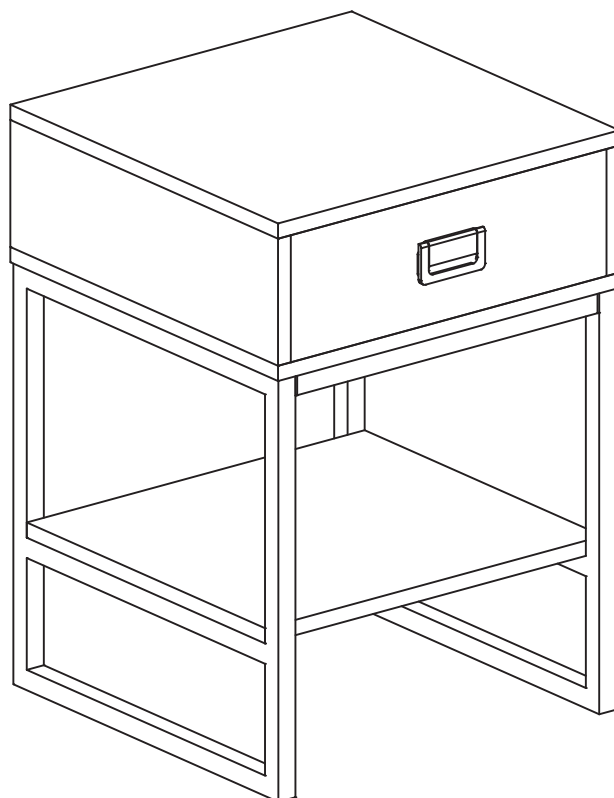

Drawer Installation Guide

- Before you insert the drawers into the frame, please ensure that the ball bearing sliders (on the assembled unit) have been placed to the front of the main unit. If the bearings are in the middle of the slider it will be difficult to install the drawers correctly.

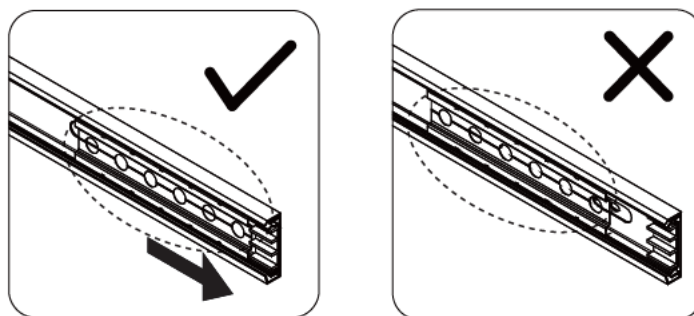

- Insert the drawer into the assembled frame as show below. Keep each side of the drawer straight and aligned correctly to the sliders on the assembled frame.

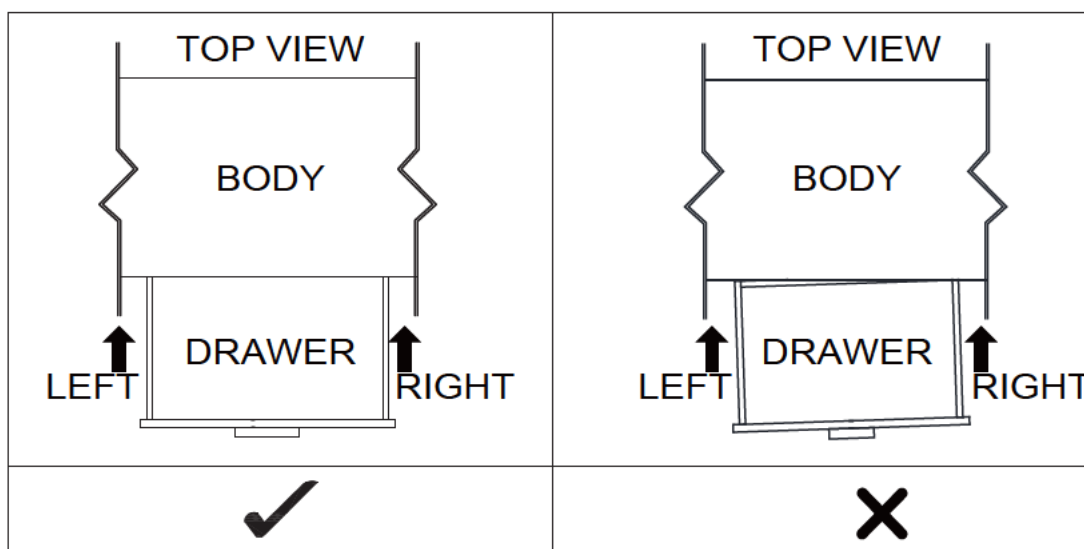

- Gently start to push the drawer into position, the drawer sliders should start to connect with the sliders on the assembled frame. Once connected apply even pressure to each side and gently push the drawer into place.
- The ball bearings should catch the drawer sliders, once they do you may find that you need to apply more pressure, this is perfectly normal as long as you are keeping the drawers straight, push the drawers 100% of the way in. Finally slide drawer in and out a few times to ensure the ball bearings are running smoothly in the slider. Installation is complete.
- At any stage throughout the install process you feel like the drawers are not evenly sliding into the assembled frame, please remove the drawers before they start to attach to the bearing slider and start the install steps again.

NOTE:

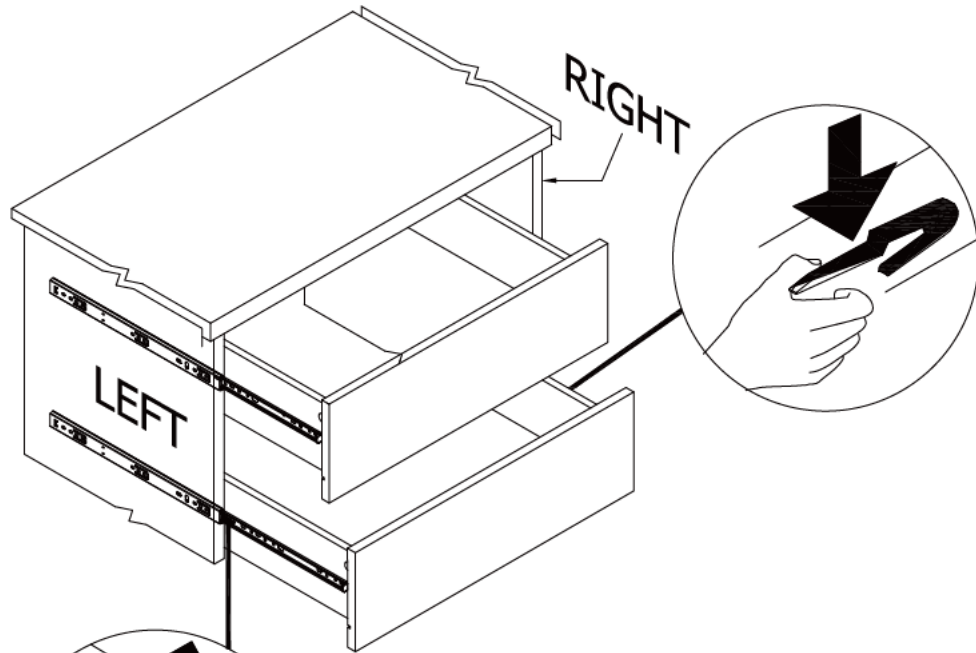

⚠ CAUTION

When removing the drawer, be careful to tip up the safety release tab on the left side, and tip it down on the right side to remove the drawer from the body as shown.

