

Installation & Operation Manual

Varpoolfaye

Thank you very much for purchasing our product, please keep this installation manual carefully and read this manual carefully before you install heat pump.

Customer service email: varpoolfayeservice@163.com

9. Product Specification

Air-source Swimming Pool Heat Pump		
Model	KSPF-007L1MR1A2	
80°F Air 80°F Water 63% RH	Heating capacity (Btu/h)	30000
	Power input(Btu/h)	5172
	COP	5.80
50°F Air 80°F Water 63% RH	Heating capacity (Btu/h)	16400
	Power input(Btu/h)	4205
	COP	3.90
Power supply	110-120V/60Hz	
Max power input (Btu/h)	5800	
Max current (A)	15.0	
Setting temperature range (Heating)	46°F~104°F	
Setting temperature range (Cooling)	46°F~82°F	
Running (Air) temperature range	19.4°F~109.4°F	
Refrigerant type/quantity (Oz)	R410A/22.9 Ozs	
Air side heat exchanger	Hydrophilic fin exchanger	
Water side heat exchanger	Titanium tube heat exchanger	
Water flow (gpm)	20	
Net dimension L×W×H (inch)	35×14×22	
Packing dimension L×W×H (inch)	40×18×25	
Net weight (lbs)	91	
Packing weight (lbs)	117	
Maximum working pressure of heat exchanger	4.4 MPa	
Maximum working pressure of exhaust side	4.4 MPa	
Maximum working pressure of suction side	2.5 MPa	
Waterproof grade	IPX4	
Noise	52dB(A)	

MENU

1. Product Schematic Diagram.....	2
2. Product Parameters	2
3. Components List	3
4. Installation Guide	4
5. Installation Materials	6
6. Heat Pump Installation Guide and User Instruction	8
7. Error Codes Trouble Shootings	12
8. Circuit Diagram	13
9. Product Specifications	14

1. Product Schematic Diagram

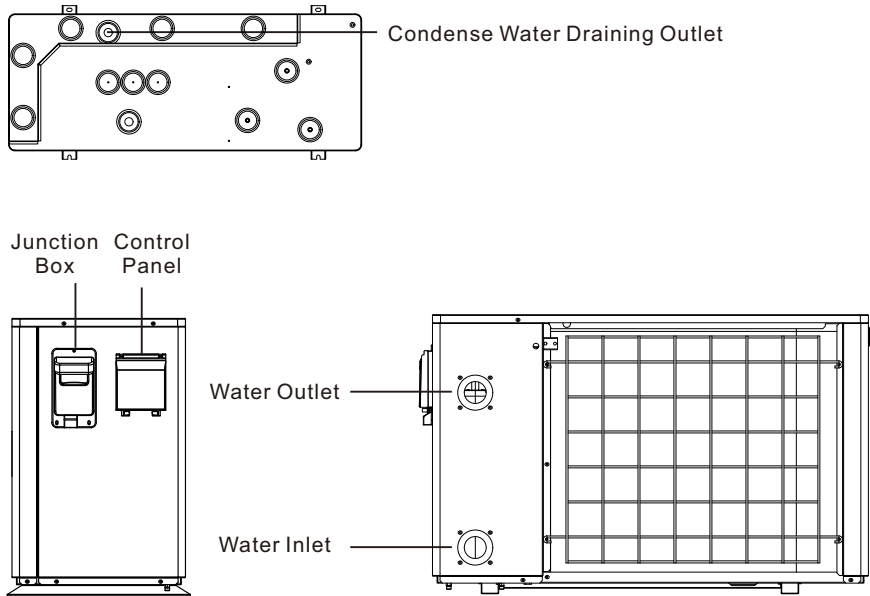

2. Product Parameters

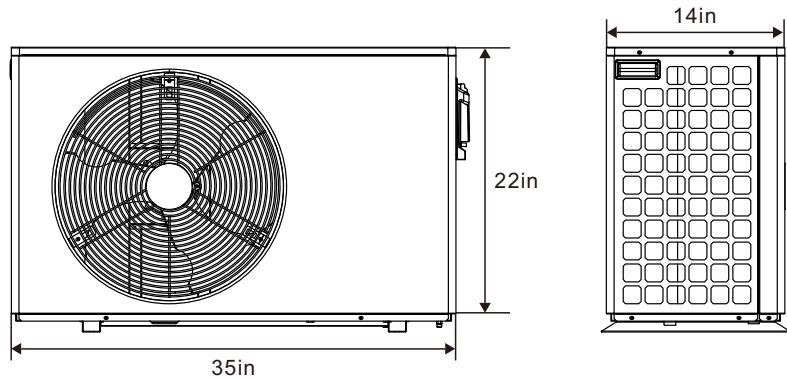

8. Circuit Diagram

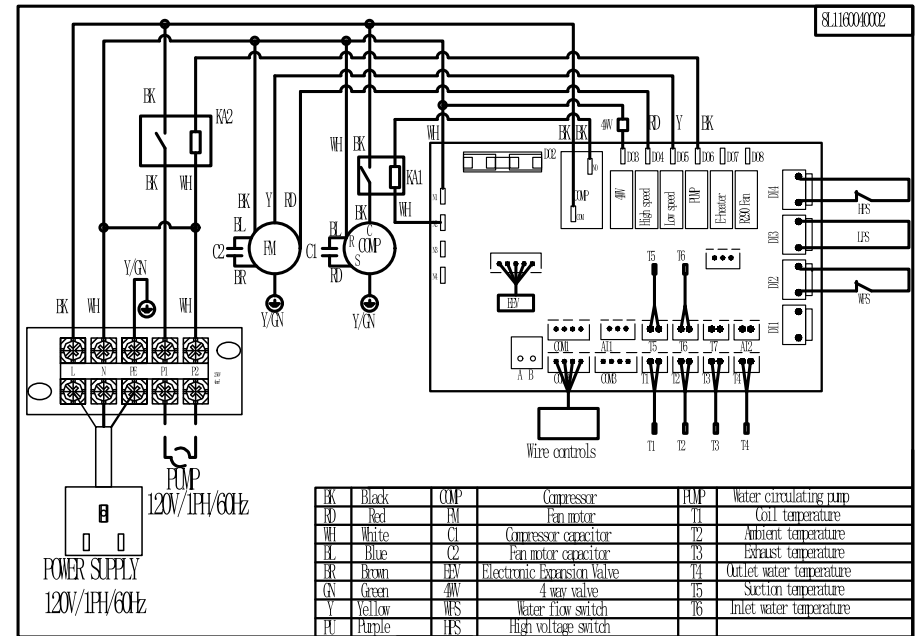

8.1 This circuit schematic diagram is for reference only, please refer to the circuit schematic diagram that printed on the heat pump casing.

8.2 Although the heat pump unit is safe against electric shock, the unit still needs to be connected to proper grounding to protect you against electric shock.

8.3 The power disconnect device (circuit breaker, with or without fuse) should be close to the heat pump unit and easily accessible to operate, it is also easy to turn off the power when the equipment is going through maintenance.

7. Error Codes Trouble Shootings

7.1 Error Codes, Causes and Solutions

Code	Error	Solution
E01	Flow switch protection	<ol style="list-style-type: none"> 1. Check the operation status of the pool pump, extract residual air in pipe line, inspect for any blockage within the pipe, and clean out any obstacle within the pipe; choose a pool pump with a greater flow rate. 2. Check the flow switch connection. 3. Exchange a new flow switch.
E02	Refrigerant outlet over heat protection	<ol style="list-style-type: none"> 1. Check the operation status of the pool pump, extract residual air in pipe line, inspect for any blockage within the pipe, and clean out any obstacle within the pipe; choose a pool pump with a greater flow rate. 2. The temperature of inlet water is too high, reduce the temperature of setting. 3. Refrigerant leakage occur, contact after sale team to repair.
E03	High pressure switch failure	<ol style="list-style-type: none"> 1. Check the operation status of the pool pump, extract residual air in pipe line, inspect for any blockage within the pipe, and clean out any obstacle within the pipe; choose a pool pump with a greater flow rate. 2. The temperature of inlet water is too high, reduce the temperature of setting. 3. Contact after sale team to exchange a new high pressure sensor.
E09	Communication failure	<ol style="list-style-type: none"> 1. Check the wiring between controller and the heat pump unit. 2. Wire damaged, exchange and repair the signal wire between controller and heat pump unit.
E11	Coil temperature sensor failure	<ol style="list-style-type: none"> 1. Check the wiring of coil temperature sensor. 2. Exchange a new coil temperature sensor.
E12	Ambient temperature sensor failure	<ol style="list-style-type: none"> 1. Check the wiring of ambient temperature sensor. 2. Exchange a new ambient temperature sensor.
E13	Refrigerant outlet temperature sensor failure	<ol style="list-style-type: none"> 1. Check the wiring of refrigerant outlet temperature sensor. 2. Exchange a new refrigerant outlet temperature sensor.
E14	Water inlet temperature sensor failure	<ol style="list-style-type: none"> 1. Check the wiring of water Inlet temperature sensor. 2. Exchange a new water Inlet temperature sensor.
E17	Refrigerant inlet temperature sensor failure	<ol style="list-style-type: none"> 1. Check the wiring of refrigerant inlet temperature sensor. 2. Exchange a new refrigerant inlet temperature sensor.
E18	Water outlet temperature sensor failure	<ol style="list-style-type: none"> 1. Check the wiring of water outlet temperature sensor. 2. Exchange a new water outlet temperature sensor.
E20	Water outlet over heat protection	<ol style="list-style-type: none"> 1. Check whether the pool pump work normally; check is there are sufficient flow within the pipe line; exchange a new pool pump. 2. Reduce the temperature of setting.
E21	Water outlet temperature too low	<ol style="list-style-type: none"> 1. Check the temperature of the pool. 2. Check the working status of the heat pump, whether it is function normally or not; if not contact after sale team for help.

3. Components List

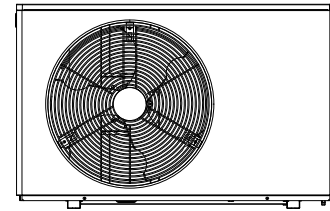

Heat Pump Unit
(1 PC)



Instruction Guide
(1 PC)

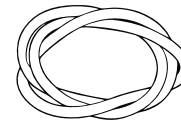

Condense Water
Draining Hose (1 PC)

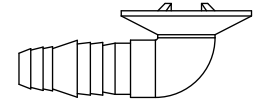

Condense Water
Draining Fitting (1 PC)

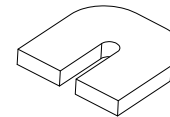

Rubber Shock
Absorption Pad (4 PC)

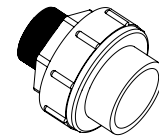

Adapter
(2 PC)

4. Installation Guide

4.1 Reminder

4.1.1 The heat pump unit must be installed in an outdoor environment. Do not install in an indoor environment without air convection which highly suppresses the performance of the product.

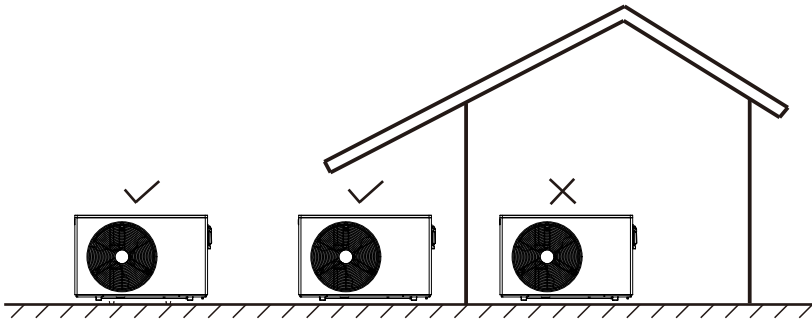

4.1.2 The heat pump must be installed at a certain distance away from surrounding obstacles (e.g. walls and bushes) as the diagram below requires for optimal operation performance.

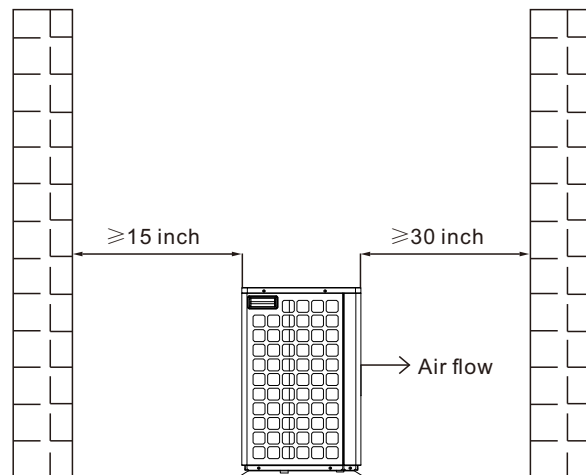

• Schedule Setting

At default display interface, press and hold '⌚' button 3 seconds to activate or deactivate scheduled operation mode. When scheduled operation mode activated, press and release '⌚' button quickly to switch hour/minutes of start/finish time setting between 3 schedule periods (Schedule 1, 2, 3). During schedule setting, the hour/minute digit, schedule period number that currently set and 'ON' 'OFF' indicator will be flashing, press '^' or '∨' button to adjust flashing hour or minute digit on the screen.

When complete setting up desire operation schedules, press and release '⏻' button quickly or let controller panel untouched for 15 seconds to save all adjustments that made, and the screen will back to default display interface.

At scheduled operation mode, heat pump only heating or cooling within scheduled time period. If a schedule have the same start and finish time, then the schedule will be canceled.

If all schedules are canceled, then the heat pump will be in operation schedule all day. (Heat pump will be in 'Scheduled Mode' only operate when you press '⏻' button and turn off by press '⏻' button again)

If you set a schedule with finish time earlier than start time, then the finish time will be consider as a finish time in tomorrow (e.g. If the start time is 22:00, the finish time is 6:00, then the heat pump will operate from 22:00 today to 6:00 in tomorrow morning). The default schedule period is: 5 :00-7 :00, 16 :00-18 :00, 20 :00-0 :00.

• Heating/Cooling mode

At default display interface, press '🔄' button can switch between heating and cooling operation mode. When switching from one mode to another, Reminder: the compressor must be stop for at least 3 minutes before operate again.





• Controller lock

At default display interface, if the controller left untouched for 30 seconds, the controller will automatically enter button locking mode. The controller can be unlock and activate by press and release any button quickly.

• WiFi Pairing

At default interface, press and hold '📶' + '∨' buttons, after you hear the buzzer beeps twice, release '📶' and '∨' buttons. After 10 seconds, the WiFi logo will flashing on the screen and indicating pairing mode is activated.

6.7.3 Controller Buttons Function

Buttons	Symbols	Functions
Power Button		<ol style="list-style-type: none"> 1. Press and hold for 1 second for power on/off. 2. Press without hold for back to default display interface.
Temperature/Time Increase Button		Setting temperature or time(hour/min)
Temperature/Time Decrease Button		Setting temperature or time(hour/min)
WiFi / Heating / Cooling Button		<ol style="list-style-type: none"> 1. Heating and cooling mode selecting. 2. Entering WiFi pairing mode.
Timer Button		<ol style="list-style-type: none"> 1. At default display interface, press for timer setting, press again for minutes or hours setting selection. 2. At default display interface, press and hold for 3 seconds for turning ON/OFF scheduled operation mode.

6.7.4 Heat Pump Controller User Instruction

• Power Button

1. Press and hold for 1 second for power on/off when controller displaying in default interface.
2. When heat pump is power on, controller will be activated, you can access and control the heat pump normally. When turning power off, '⏻' will not displayed on the screen, controller stops transferring any command signal to the heat pump unit. Controller screen will keep displaying and setting can be made on the controller when heat pump power is off. The controller will be in off mode by default when the heat pump unit first connected to power supply.

• Temperature Setting

Press and release '∧' or '∨' button quickly to enter temperature setting mode. Temperature setting indicator 'ST' will be displayed, set temperature values will be displayed according to the operation mode (heating / cooling). In setting mode, press '∧' or '∨' button to adjust temperature.

• System Time Setting

At default display interface, press and release '🕒' button quickly to enter system time setting mode. At system time setting interface, press '🕒' button once, 'hour' indicator will be flashing, press '∧' or '∨' button to adjust hour number. When hour setting is complete, press '🕒' button and 'minutes indicator will be flashing, press '∧' or '∨' button to adjust minute number. When system time setting completed, press '🕒' button to exit time setting mode and back to default display interface.

At system time setting mode, if there is no adjustment made for 5 seconds, the system time will be set as displayed digit and back to default display interface.

4.2 WARNING

When using an outdoor power supply, please use a power socket with a waterproof rating of IPX6 that features a rain cover for protection against electricity leakage caused by any water splashing into the plug/power socket. Voltage requirement: 120V/60Hz.

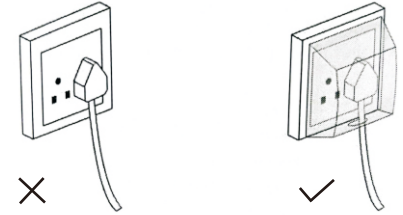

4.3 WARNING

In winter or any period with environment temperature below freezing point, please disconnect the hose that connects with the heat pump unit, and let water drain out from the inlet/outlet freely to avoid any damage to the heat exchange unit or pipe in the heat pump caused by ice expansion.

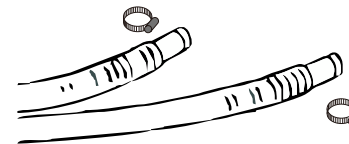
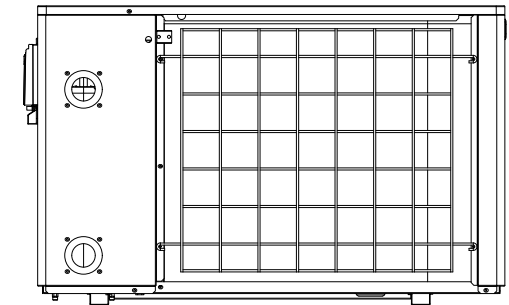
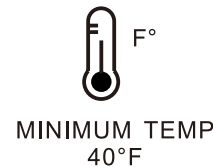

5. Installation Materials

5.1 For Installation with Above Ground Pool

Reminder: The heat pump unit must be installed on a level and solid surface (e.g. flat ceramic or thick tile plate) for stable and optimal performance.

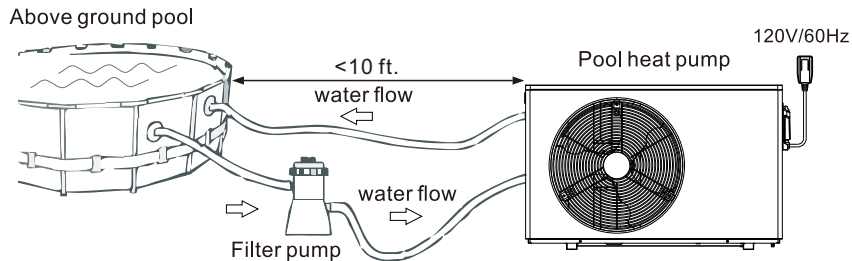

Diagram 1

Materials Required for Installation of Above Ground Pool Use:

5.1.1 Pipes: A Minimum of 3 pipes are required for the setup above. 1.5" PVC hoses are recommended in this case. However hard PVC pipes also work perfectly for this above ground system.

5.1.2 For best heating efficiency for the pool, please install the heat pump as close as possible to the pool, with a length of hose between the water outlet of the heat pump and the pool less than 10ft, which reduces heat loss through the hose to the surrounding.

5.1.3 Total of 6 stainless steel hose clamps are required for all pipes installation, which are installed at the front and rear connection positions of each pipe fitting.

5.1.4 For better energy and heating efficiency, please apply a solar cover to the pool for less heat loss to the air.

5.1.5 The heat pump unit must cooperate with a water pump with a recommended flow rate >1500GPH. Both filter pumps or a self-priming pool pump connected in series to a cartridge filter will work perfectly for the setup above.

5.1.6 You can always add extra components like a chlorinator to the system according to your needs.

5.1.7 Tools required for installation: Cross screwdriver, spanner.

6.7.2 Controller Indicator States & Explanation

Indicator Symbol	State	Explanation
	Lights On	Heat pump is power on.
	Lights Off	Heat pump is power off.
	Displaying	Heat pump in cooling mode.
	Displaying	Heat pump in heating mode.
	Displaying	Error/malfunction occur.
ST Temperature	Flashing	When setting temperature.
IN Temperature	Displaying	Inlet water temperature.
	Displaying	Indicating temperature.
	Displaying	Indicating time, error codes.
	Displaying	Scheduled operation mode activated.
	Displaying	At scheduled operation period.
ON	Flashing	Setting the starting time of specific schedule.
	Displaying	At scheduled operation mode, but not in any scheduled period.
OFF	Flashing	Setting the finishing time of specific schedule.
1	Displaying/Not Displaying	Displays when setting operation schedule #1, no display in other period.
2	Displaying/Not Displaying	Displays when setting operation schedule #2, no display in other period.
3	Displaying/Not Displaying	Displays when setting operation schedule #3, no display in other period.
	Displaying	Circulation pump operating.
	Displaying	Heat pump at operating condition.
	Displaying	Defrost mode activated.
	Displaying	Button locked.
	Displaying	Under WiFi connection.
	Rapid-Flashing	Heat pump in AP pairing mode (200ms between each flash).
	Slow-Flashing	Pairing not complete.
	Off	Pairing did not success within 3 minutes, WiFi unit automatically turn off.

6. Heat Pump Installation Guide and User Instruction

6.1 When all materials and components for your desired pool setup are fully prepared, install all components and materials in a suitable position according to the actual condition and surrounding environment of your pool. Remember, the heat pump must be installed within 10ft of the pool, on a level and solid surface.

6.2 With respect to your actual pool setup, install and connect all components according to the schematic diagram shown.

6.3 Fill up the pool after completing your pool system installation, filling the pool until the water surface fully covers both the water inlet and outlet of the pool. Please make sure and check that the pool pump and heat pump must be fully filled.

6.4 After filling water to the pool, turn on the pump and inspect whether it is normal or not the water flow is. If not, try to extract all residual air within the pipeline, pool pump, and heat pump.

6.5 After inspection of the water flow, turn on the power supply of the heat pump.

6.6 Press the power button and turn on the heat pump. When the heat pump functions properly, there will be normal running sounds of the fan and compressor, and condensed water will drain out at the bottom outlet.

6.7 Heat Pump Controller Instruction:

6.7.1 Controller Functions:

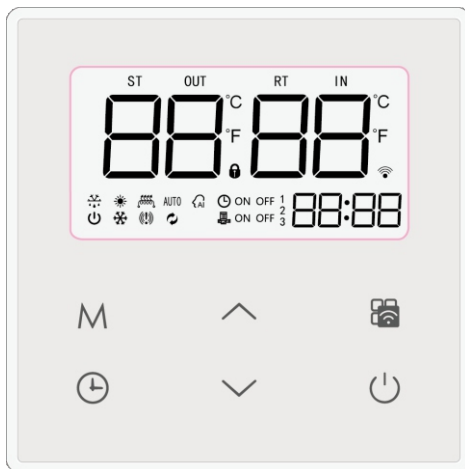

5.2 For Installation with In-Ground Pool

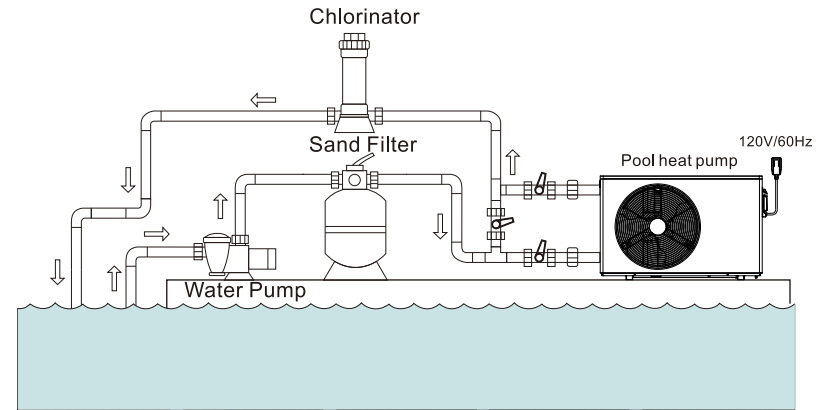

Diagram 2

Materials Required for Installation of In Ground Pool Use:

5.2.1 Pipes: For in-ground pool setup, hard PVC pipes are recommended in this system setup. The diameter of the pipes required is 1.5". You will need to cut the pipes to the length that fits your ideal pool design;

5.2.2 For best heating efficiency for the pool, please install the heat pump as close as possible to the pool, with a length of pipe between the water outlet of the heat pump and the pool less than 10ft, which reduces heat loss through the pipe to the surrounding.

5.2.3 For the setup above, a total of 2 PVC union pipe fittings(1.5") need to be installed at both the water inlet and outlet of the heat pump for pipe connection to the system. 3 sets of 1.5" ball valves need to be installed in the system as shown above.

5.2.4 For better energy and heating efficiency, please apply a solar cover to the pool for less heat loss to the air.

5.2.5 The heat pump unit must cooperate with a water pump with a recommended flow rate of >1500GPH. Both filter pumps or a self-priming pool pump connected in series to a cartridge filter will work perfectly for the setup above.

5.2.6 Add any sufficient PVC elbows for your pipeline design, and you can always add extra components like a chlorinator or sand filter to the system according to your needs.

5.2.7 Tools required for installation: Cross screwdriver, spanner, and PVC glue.