

# ASSEMBLY AND INSTALLATION INSTRUCTIONS

Item No: BD054-2

**WARNING: TO AVOID RISK OF ELECTRICAL SHOCK, BE SURE TO SHUT OFF POWER WHILE INSTALLING OR SERVICING THIS FIXTURE.**

## NOTES:

1. Before installing, consult local electrical codes for wiring and grounding requirements.
2. Read and save these instructions.
3. Always switch off the electricity supply and allow to cool for 10 minutes before changing the light bulbs.

## 1-LIGHT WALL SCONCE

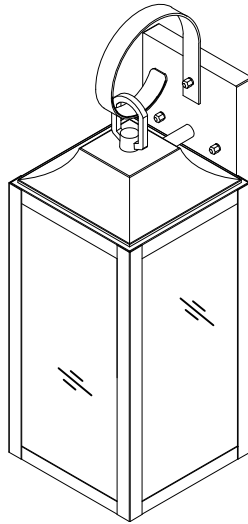

## TOOLS REQUIRED

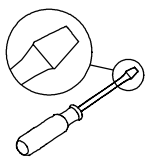

Flathead  
Screwdriver



Phillips  
Screwdriver



Ladder

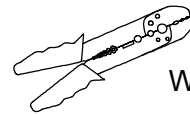

Wire Strippers

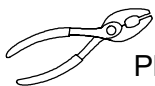

Pliers



Electrical  
Tape

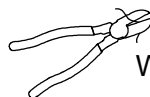

Wire Cutters

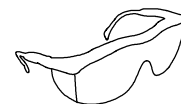

Safety Glasses

## PREPARATION

Before beginning assembly of product, make sure all parts are present. Compare parts with package contents list and hardware contents list. If any part is missing or damaged, do not attempt to assemble the product. When the lamp is not installed finish, please don't throw away the package, so as not to leave the parts in the package.

## PART LIST AND HARDWARE LIST

| PIECE | DESCRIPTION        | QUANTITY |
|-------|--------------------|----------|
| A     | Wire nut           | 3        |
| B     | Mounting plate     | 1        |
| C     | Outlet box screw   | 2        |
| D     | Green ground screw | 1        |
| E     | Rubber Pads        | 3        |
| F     | Decorative Nuts    | 3        |
| G     | Fixture body       | 1        |
| H     | Screw              | 1        |
| I     | Bent Metal Strip   | 1        |
|       |                    |          |
|       |                    |          |

## INSTALLATION

1. Attach the Mounting plate (B) to the junction box with outlet box screw (C) then fix it.
2. Loosen the screw (H) and then remove the Bent Metal Strip (I). Hook the elbow into the lifting ring of the lamp bracket (G), and use screws (H) to pass through the elbow hole and tighten it in the original removal position
3. Install two maximum 40W B-type light bulbs (not included) onto the lamp holder
4. Attach the supply circuit ground wire (green or bare copper wire) to the the fixture ground wire, black to (black) and white to (white).
5. Insert the fixture body (G) onto the mounting plate (B). Lock with 2 decorative nuts (F) and 2 rubber pads (E)

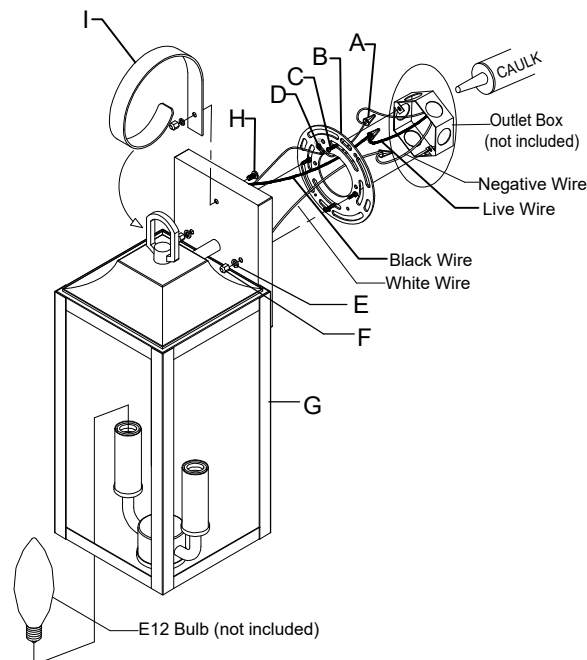

If you have any issues with use this product, please email us. Be sure to include your order number and photos of the issues. This will help us provide you with faster support and solve your problem.

 [lighting\\_service@outlook.com](mailto:lighting_service@outlook.com)