

# Crater Glass Shelf Installation Guide

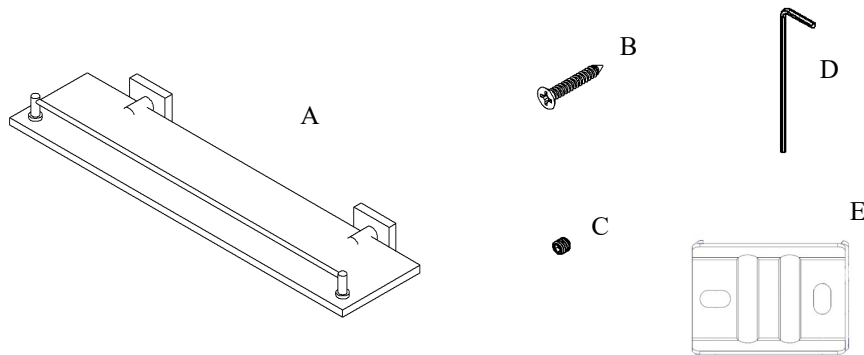

Parts Included	QTY
A - Shelf	1
B - Screw	4
C - Set Screw	2
D - Allen Key	1
E - Bracket	2

Description	Finish	Weight (lb)	WxHxD (mm)	WxHxD (Inches)	Metal Type
Crater Glass Shelf	Chrome	3.344	520 x 57 x 141	20.5 x 2.25 x 5.5	Brass
Crater Glass Shelf	Brushed Nickel	3.344	520 x 57 x 141	20.5 x 2.25 x 5.5	Brass
Crater Glass Shelf	Matte Black	3.344	520 x 57 x 141	20.5 x 2.25 x 5.5	Brass

**Warranty:** 2 Years

**Care & Maintenance:** A periodic wash using warm water and a soft cloth will retain the high quality finish of your product for many years to come. ON NO ACCOUNT should any household bleaches, detergents, abrasive polishes, steel wool or other cleaning agents be used on this item.

