

ASSEMBLY INSTRUCTIONS

TOOLS REQUIRED:

Allen key (supplied, part # C)

BEFORE YOU START:

1. Check the parts against the parts list to make sure all items are present.
2. Assemble your furniture on a soft, flat surface to avoid scratching the finish.
3. **CAUTION:** Do not over tighten screws, nuts or bolts during assembly.
4. Your furniture may require occasional tightening.

INSTRUCTIONS:

1. Carefully lay table top upside down on a flat, soft surface. Attach four legs to the iron table frame, using Bolt (A). Tighten with Allen key (C). (See Figure 1).
2. Remove the panel shelf from the iron shelf. (see Figure 2)
3. Turn the iron shelf upside down. Install iron shelf on bottom of Legs, align pre-drilled holes in iron shelf with hole in bottom of Legs. Insert hanger bolt on Bun foot through pre-drilled holes on iron shelf & into metal insert bottom of Legs as shown. Tighten all & align Bun foot. (Figure 3).
4. Install the panel into the iron shelf. (see Figure 4).
5. Install glass shelf into the iron shelf. (see Figure 5).
6. Install the felt plastic bumpers on the corners of the top iron table frame. (see Figure 6).
7. Carefully install the top glass into the top iron table frame. (see Figure 7).

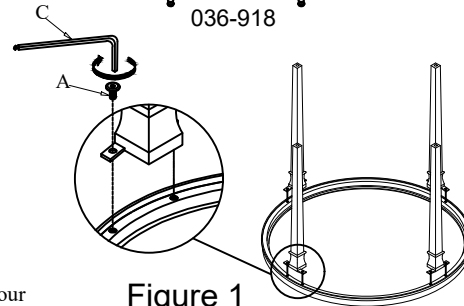
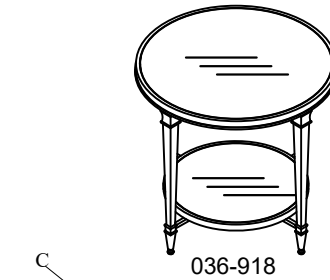

Figure 1

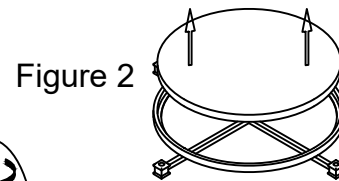

Figure 2

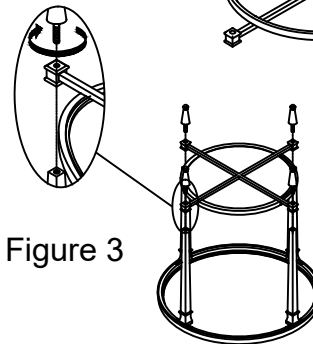

Figure 3

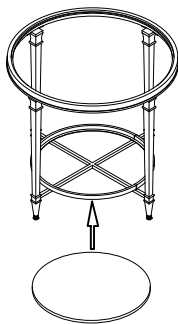

Figure 4

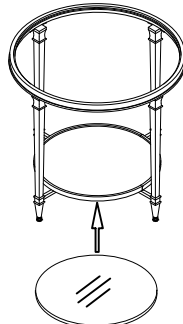

Figure 5

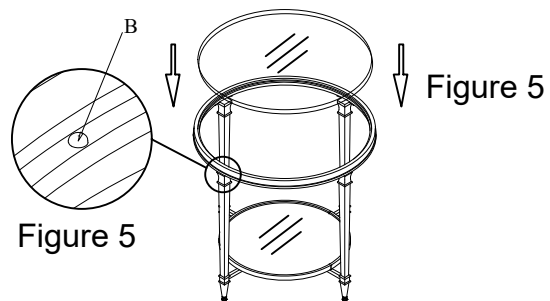





Figure 5

No.		Hardware List	Q'ty
A		Bolt Ø1/4"xL5/8"	8
B		Felt plastic bumpers	4
C		Allen Key 4mm	1