

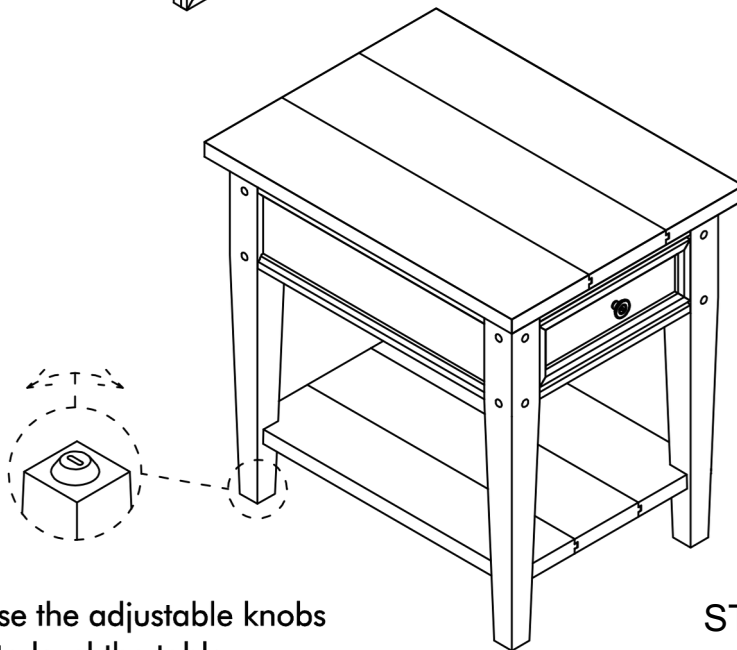

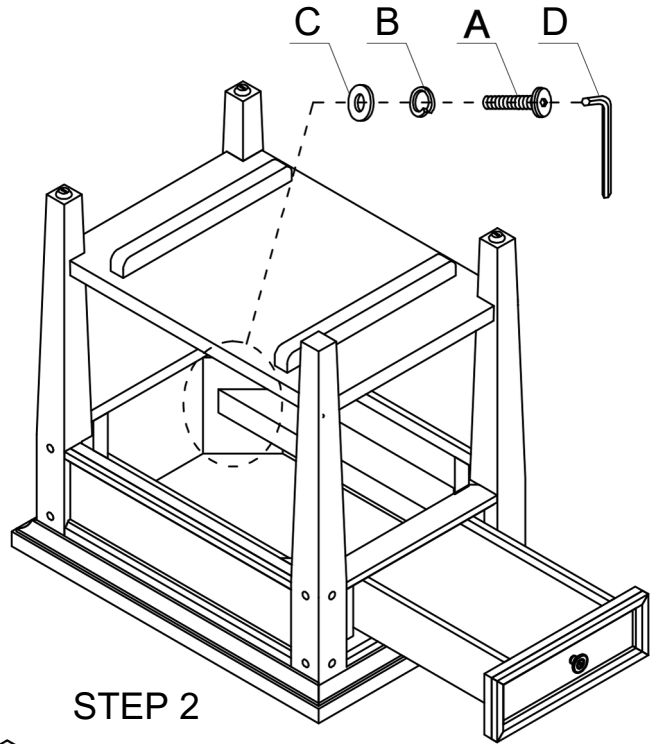

ASSEMBLY INSTRUCTION

CHAIR SIDE CABINET

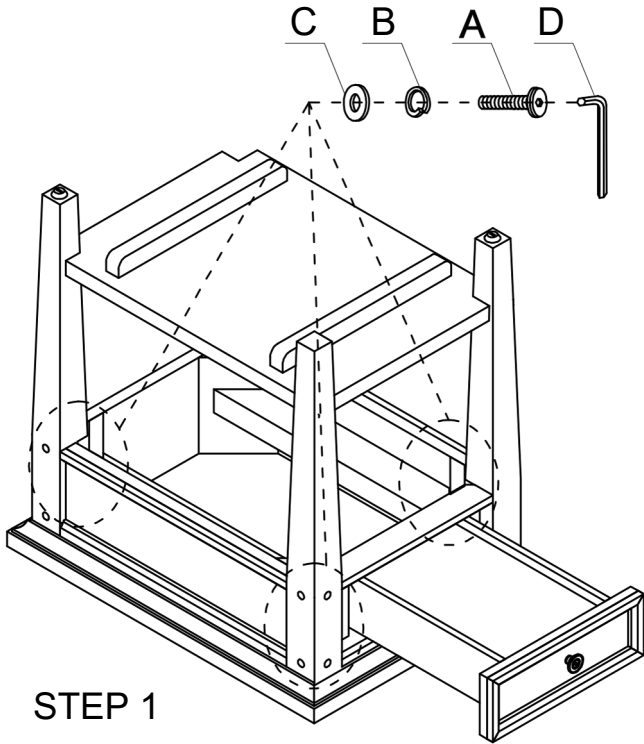

Please use the adjustable knobs
to level the table

**DO NOT TIGHTEN SCREWS
UNTIL COMPLETELY ASSEMBLED**

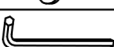
Item	Sketch	Description	Qty
A		Bolt 1/4"x2-1/2"	8 Pcs
B		Lock Washer 1/4"	8 Pcs
C		Flat Washer 1/4"x18	8 Pcs
D		Allen Wrench 1/4"	1 Pc