







Instruction Manual

Thank you for shopping with us!

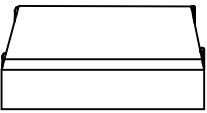
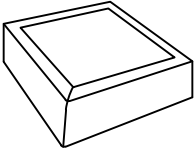
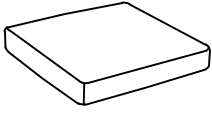
If any part is missing, broken upon receipt or you need any help from us. For the FASTEST solutions, please FIRSTLY CONTACT US at our after-sales

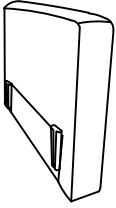
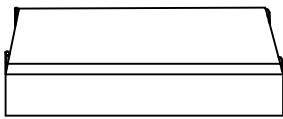
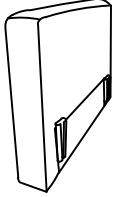
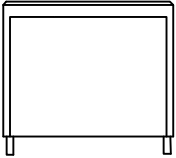
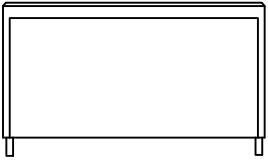
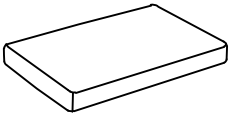
Accessories list

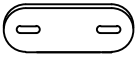
Note: All the parts or hardware marked with * are tucked under A, B or F

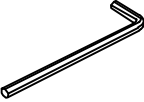
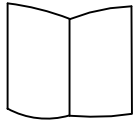
<p>A</p>  <p>Single seat frame(1)</p>	<p>B</p>  <p>Ottoman frame(1)</p>	<p>C*</p>  <p>Seat cushion(2)</p>	<p>D*</p>  <p>Back cushion(3)</p>
<p>E</p>  <p>Left armrest(1)</p>	<p>F</p>  <p>Double seat frame(1)</p>	<p>G*</p>  <p>Right armrest(1)</p>	<p>H*</p>  <p>Single backrest(1)</p>
<p>I*</p>  <p>Double backrest(1)</p>	<p>J*</p>  <p>Double seat cushion(1)</p>	<p>K*</p>  <p>Leg(10)</p>	<p>L*</p>  <p>50 Metal plate(1)</p>
<p>M*</p>  <p>6*25 Screw(2)</p>	<p>N*</p>  <p>13mm Gasket(2)</p>	<p>O*</p>  <p>M4*65*23 Wrench(1)</p>	 <p>Instruction Manual(1)</p>

STEP 1:

Get all the hidden parts out of F, A and B

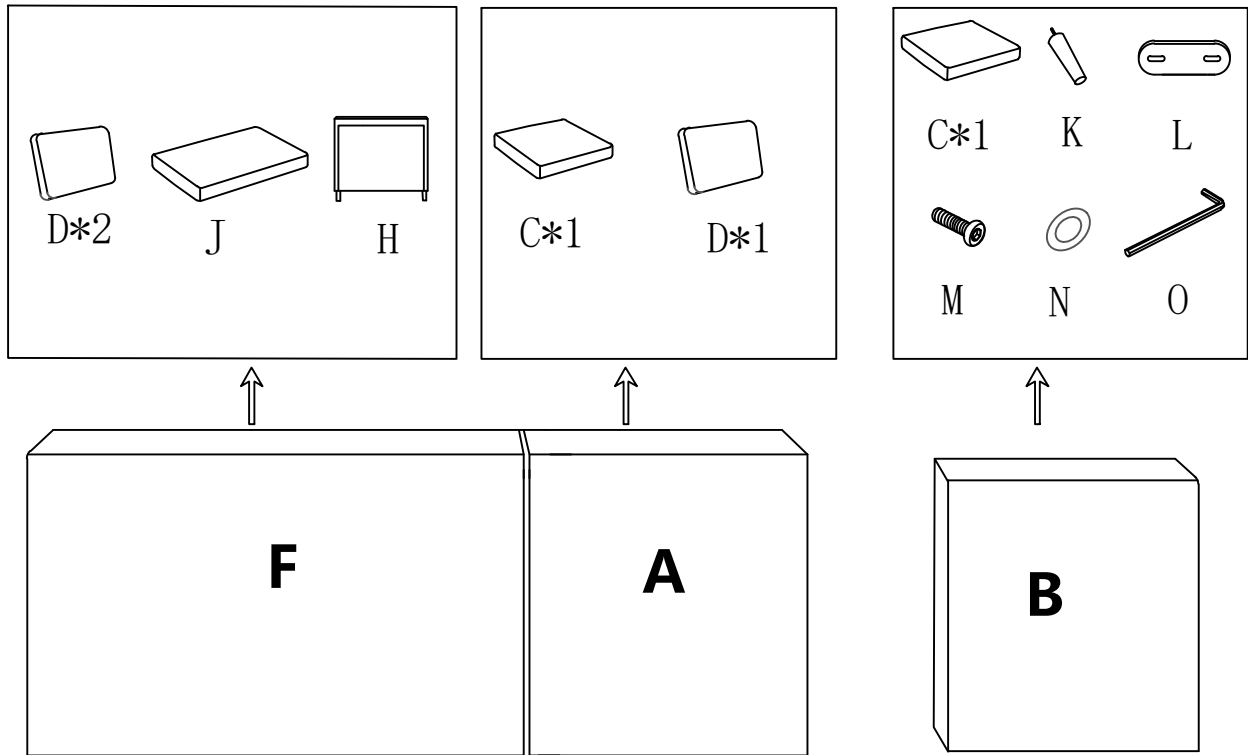

STEP 2:

Insert Single seat frame A to Left armrest E

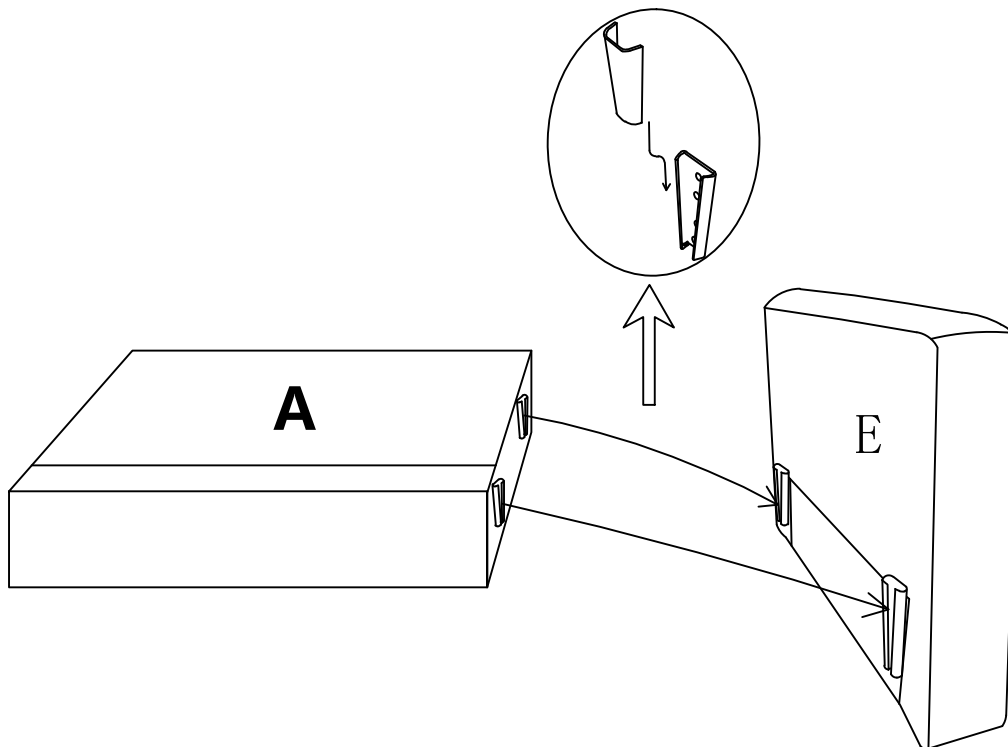

STEP 3:

Insert double seat frame F to Left armrest G

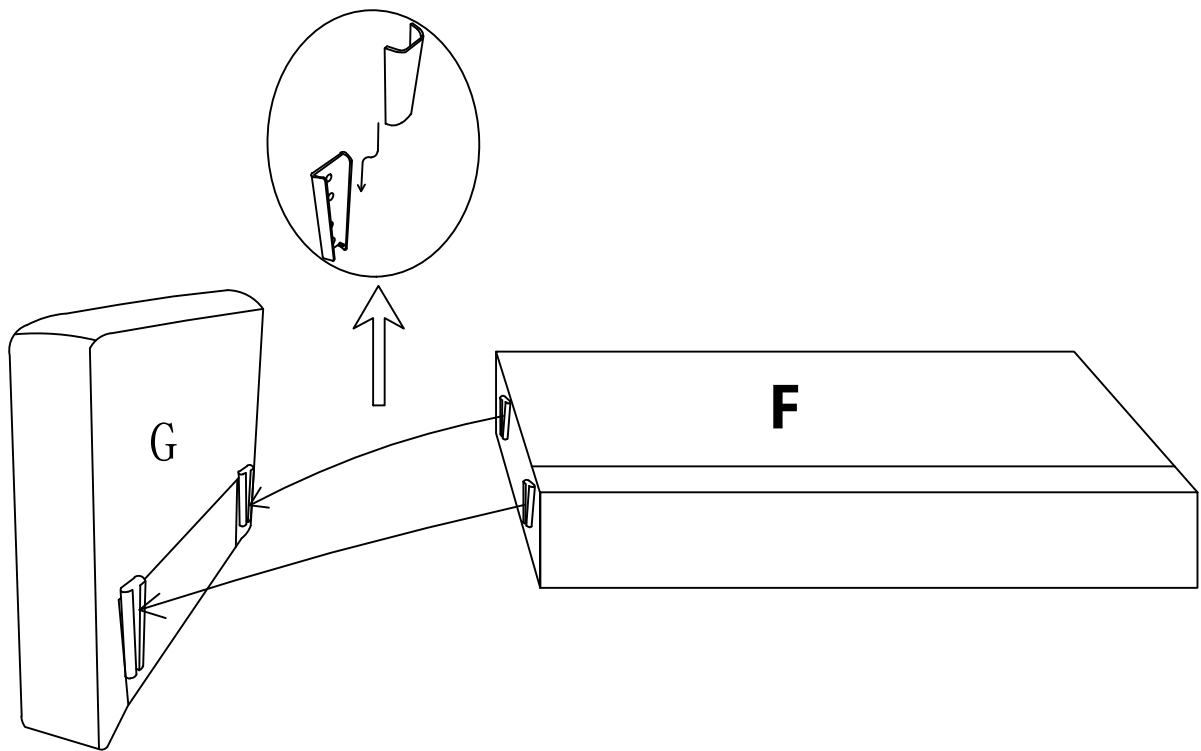

STEP 4:

Install the Legs K

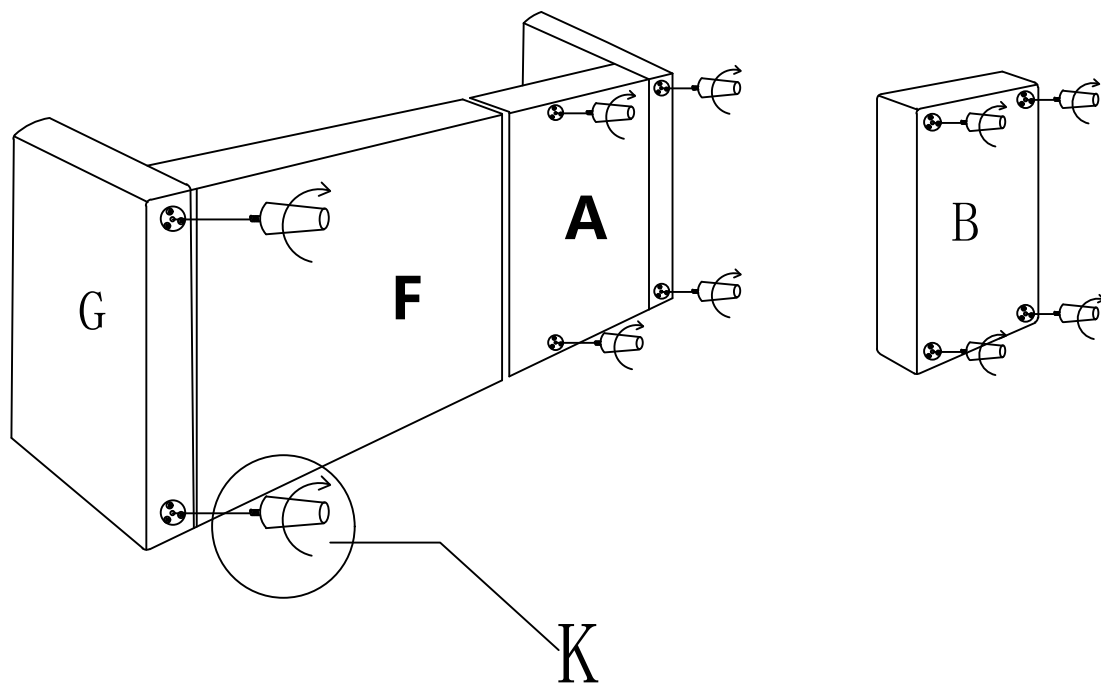

STEP 5:

Insert Double seat frame F to Single seat frame A

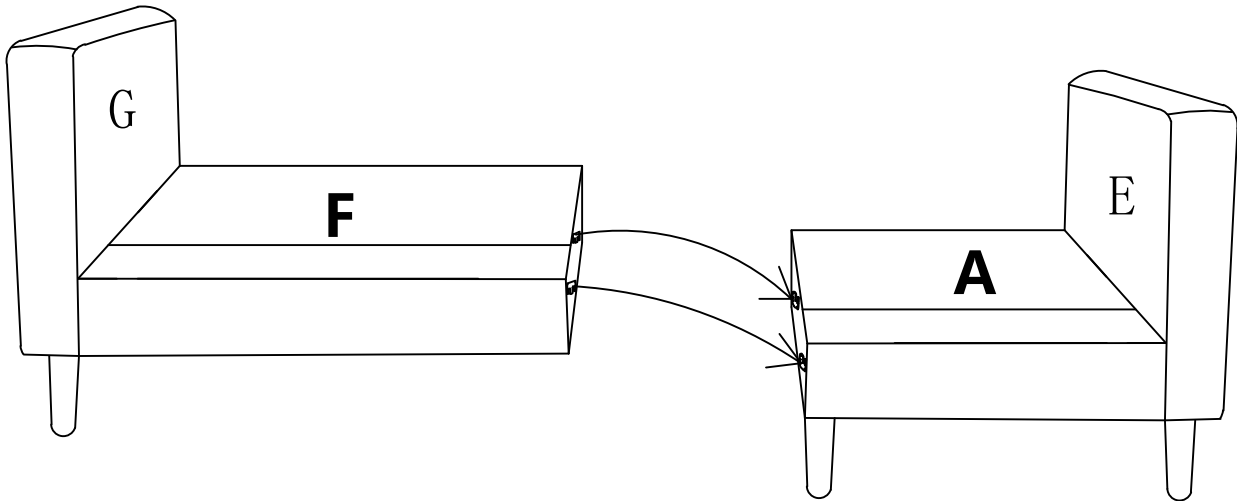

STEP 6:

Insert I into F, insert H into A
Push the back till it stops

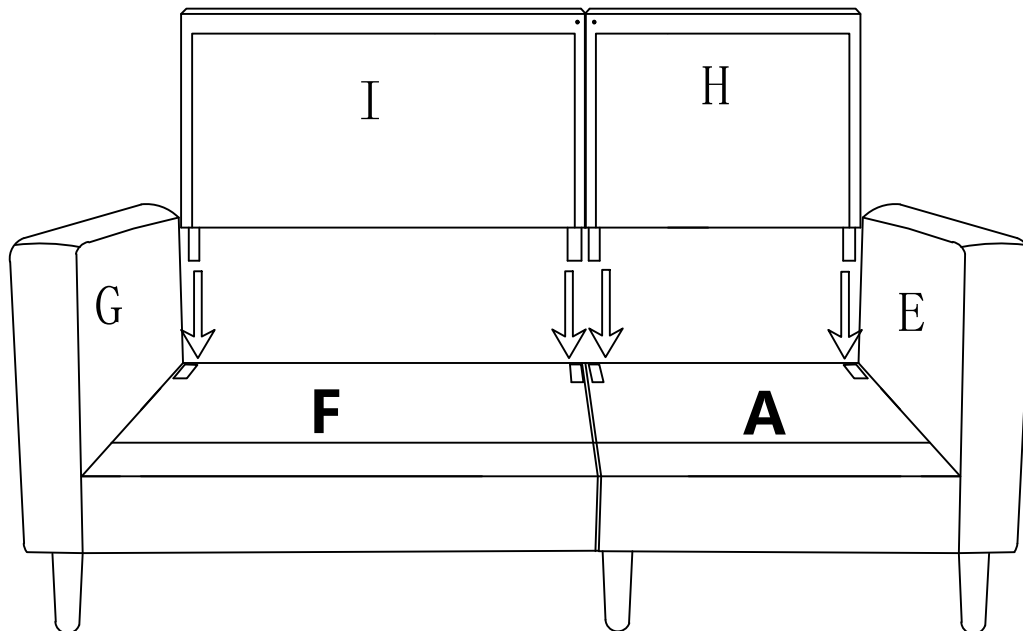

STEP 7:

Lock the backrest with the metal plate

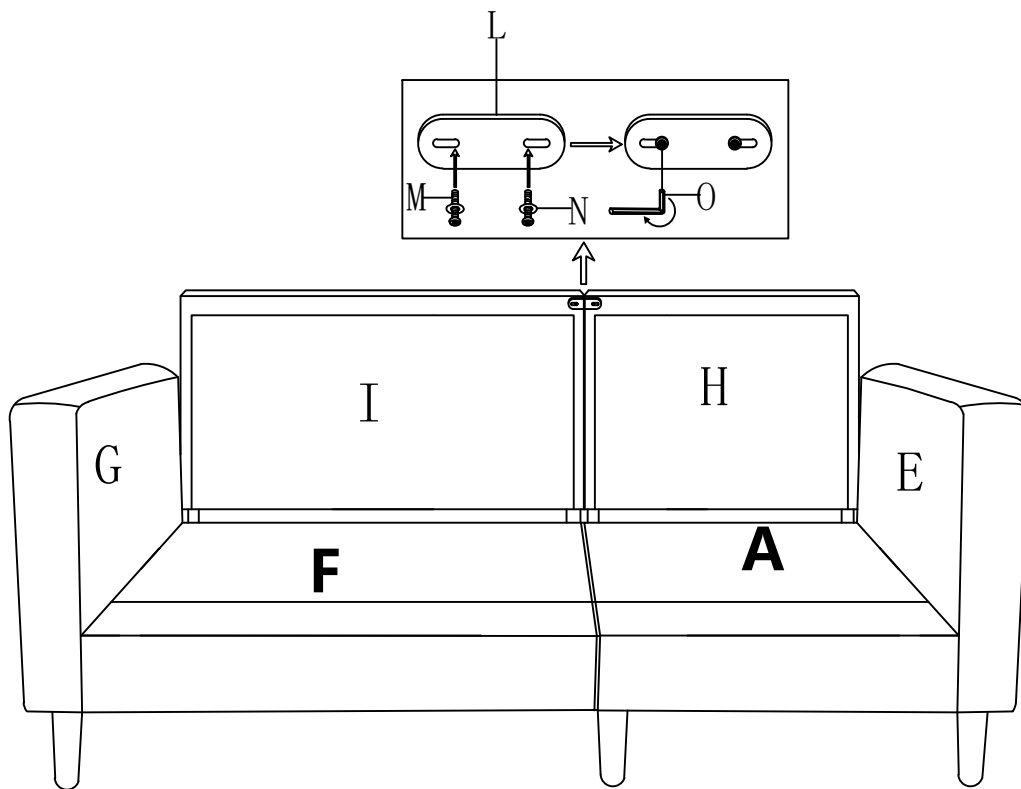

STEP 8:

Flip the backrest cloth and stick the Velcro on the backrest cloth to the seat frame

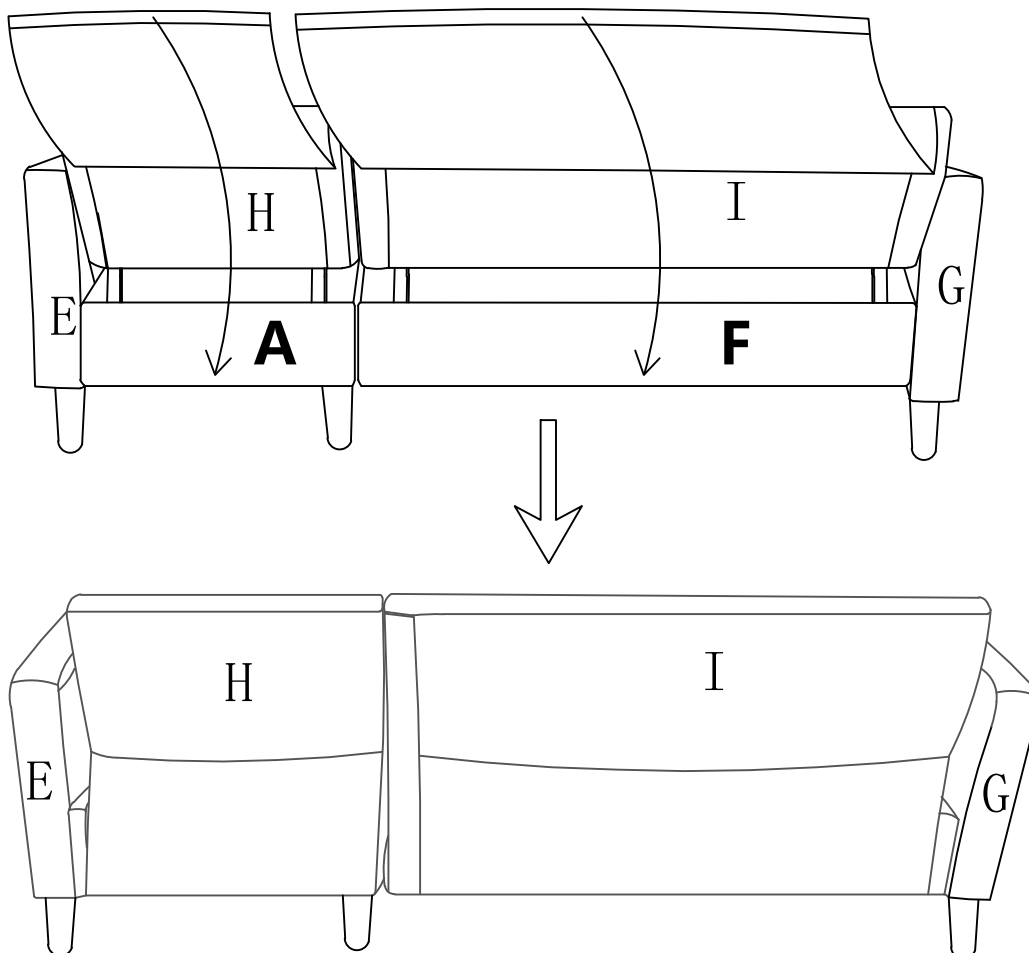

STEP 9:

Cut off the compression bag and tear off the Velcro

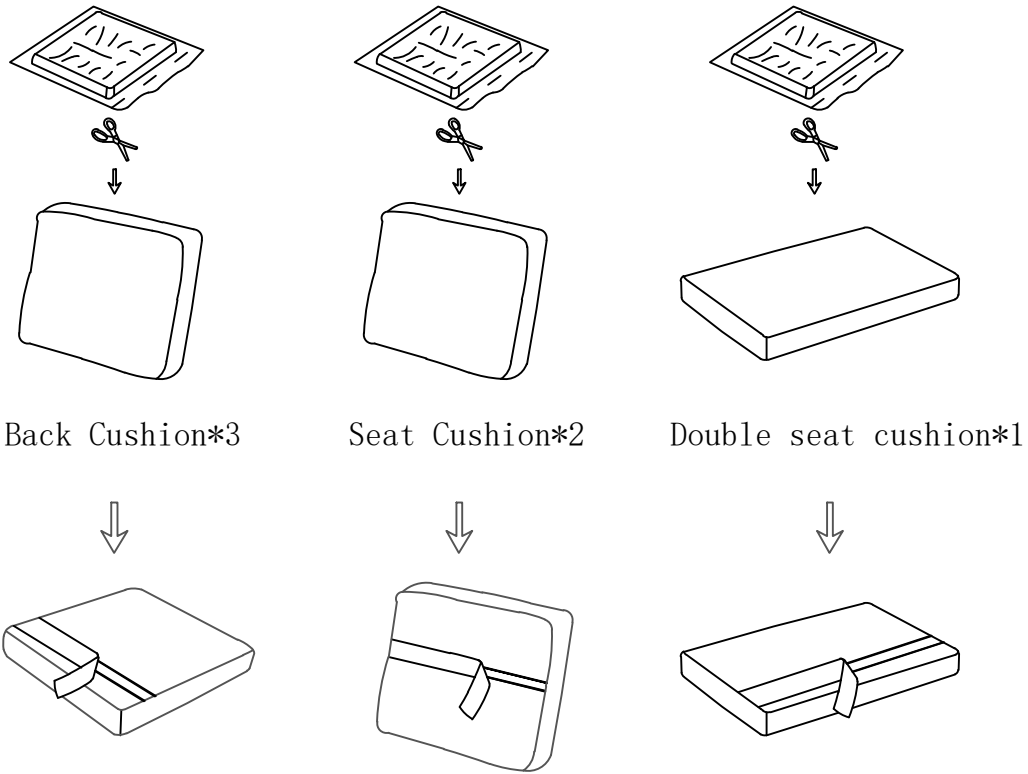

STEP 10:

Put the seat cushion and then the back cushions on the sofa

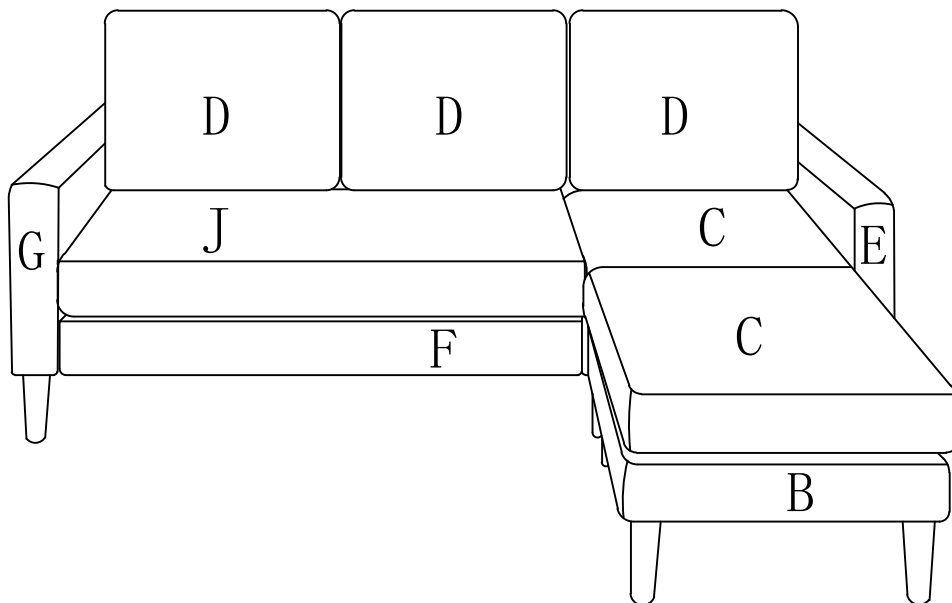

Tip:

1. Cushions are compressed to prevent humidity and mold, sometimes it's inevitable to find some wrinkles when you get them out, you can iron them or use them to help them to get back into the original shape.
2. Hand wash is preferred for daily care.