

# BENCH

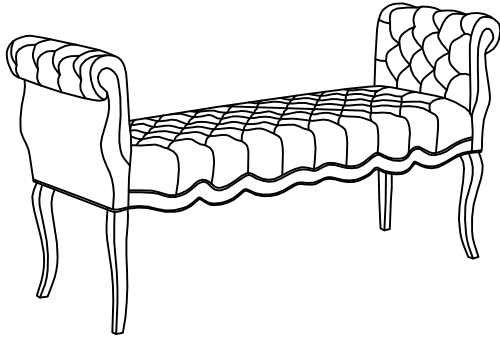



Thank you for purchasing the BENCH!

Before you start, here is some helpful advice:

1. We suggest you spend a short time reading through this leaflet and then follow the simple step by step instructions.
2. Owing to the size and weight of the bench, we recommend that it is assembled by two adults, on a carpeted or padded area, in the room that it is intended for. Approximate assembly time: 15 minutes.
3. Please do not use any tools other than those provided or recommended in these instructions.
4. Please do not throw away any of the packaging or instructions until you have checked all the components and hardware and the furniture is fully assembled.
5. Assemble all components loosely until advised to tighten. Depending on use, it may be necessary to tighten the components from time to time, so please save the tools that have been provided.
6. Please keep all pieces out of reach of small children.



## Hardware:

1		JCBC BOLT M6 x 80	8 PCS
2		JCBC BOLT M6 x 45	4 PCS
3		FLAT WASHER M6	12 PCS
4		SPRING WASHER M6	12 PCS
5		ALLEN KEY (BALL SHAPE) M4	1 PC

## Component:

A.	BENCH	x 1
B.	LEG (L/R)	x 2

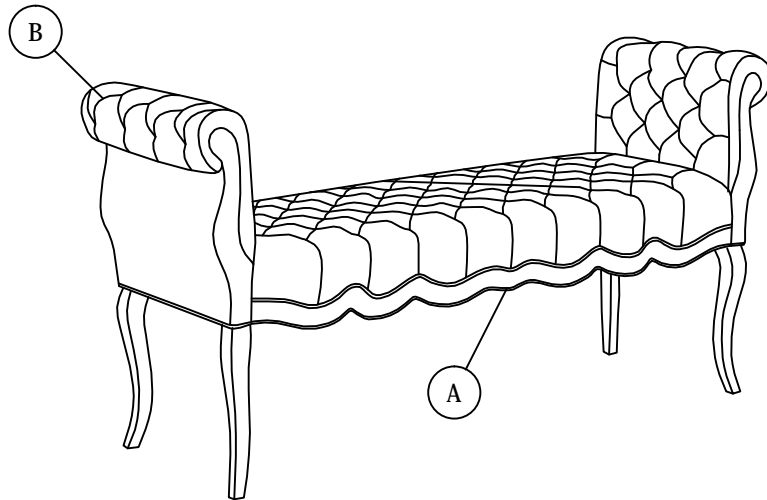



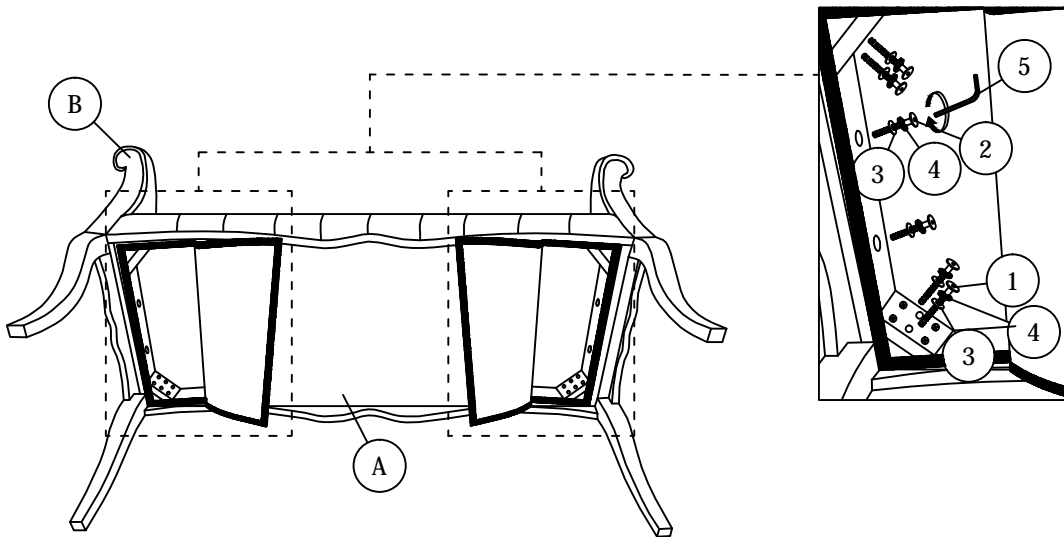

# BENCH

## STEP 1

1.1 Insert and secure the leg L/R (B) to the bench (A) using hardware parts 1,2,3,4 and 5. Repeat the same for other side of leg.



			
1. JCBC BOLT M6 x 80 x 8pcs	4. SPRING WASHER M6 x 12pcs	3. FLAT WASHER M6 x 12pcs	5. ALLEN KEY (BALL SHAPE) M4 x 1pc

2. JCBC BOLT M6 x 45 x 4pcs

## STEP 2

Carefully turn over the bench.

