

# Assembly instructions

## L-shaped desk

Model:06-10DK01L71-WG

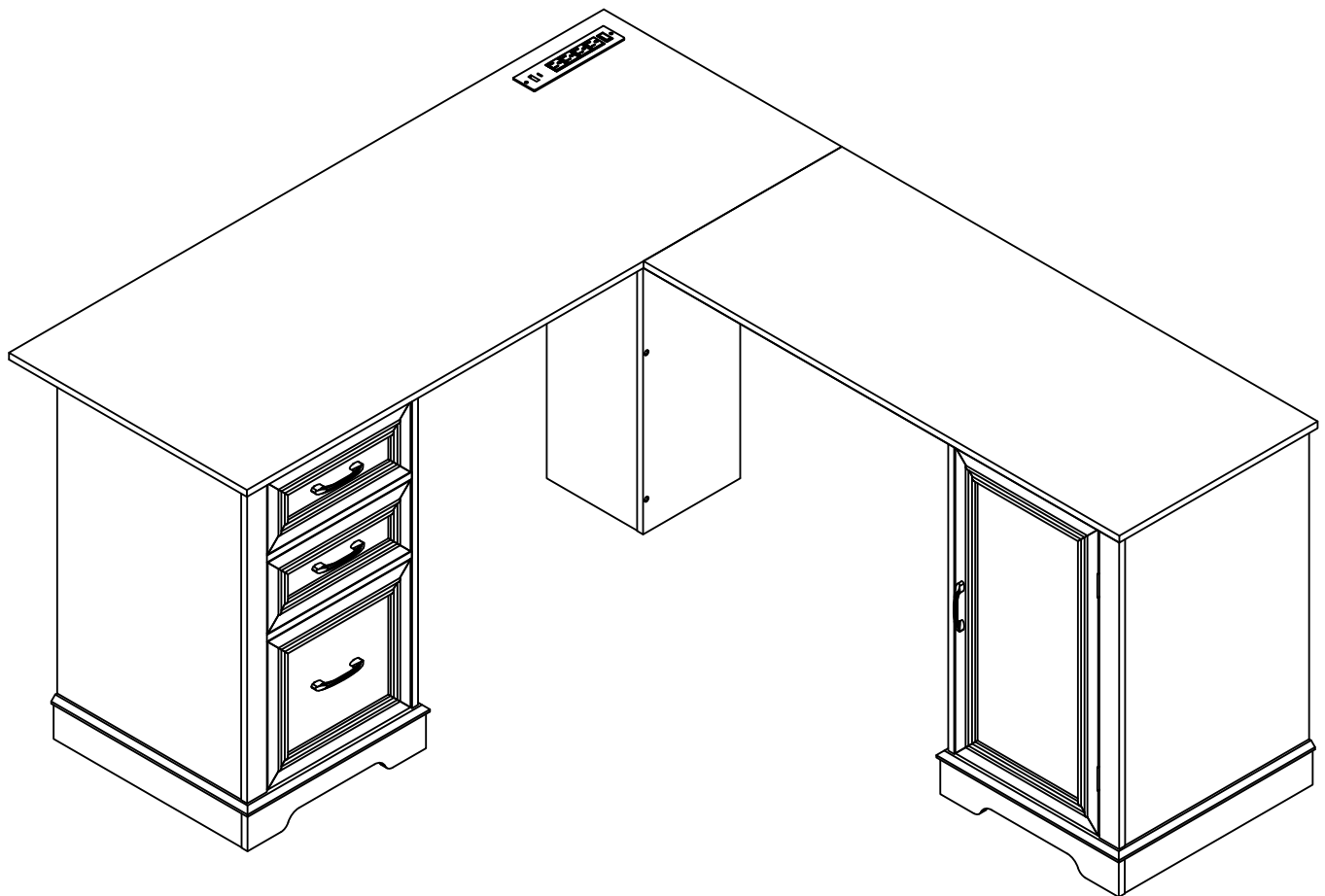

### MADE IN P.R.C.

Thank you for your purchase.All components are included in a single package. Please follow the instructions step by step for a quicker and smoother installation process.If you encounter any issues,please contact our customer service team [service@theyulika.com](mailto:service@theyulika.com),and we will be pleased to assist you.

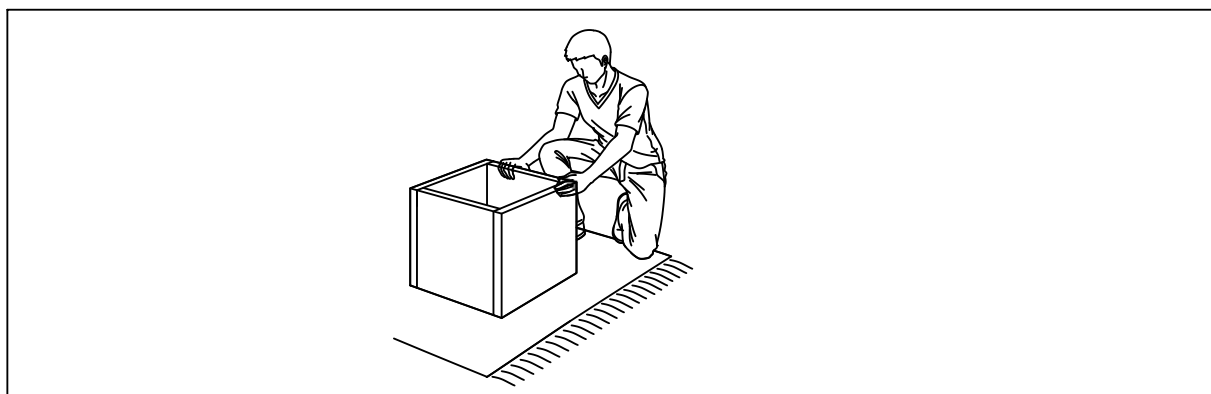
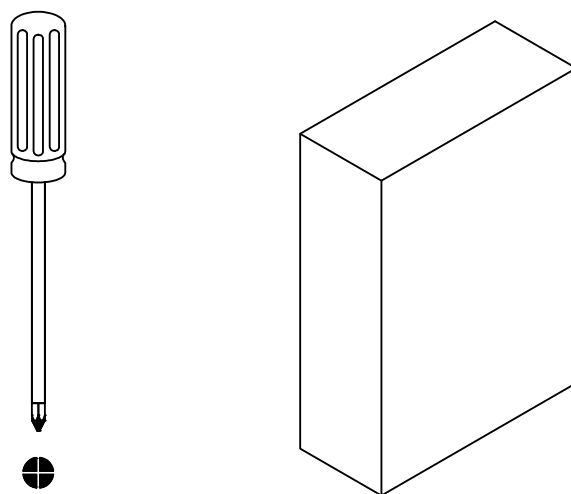

Assemble the furniture on empty carton, carpet, or rug to prevent scratches or damage.

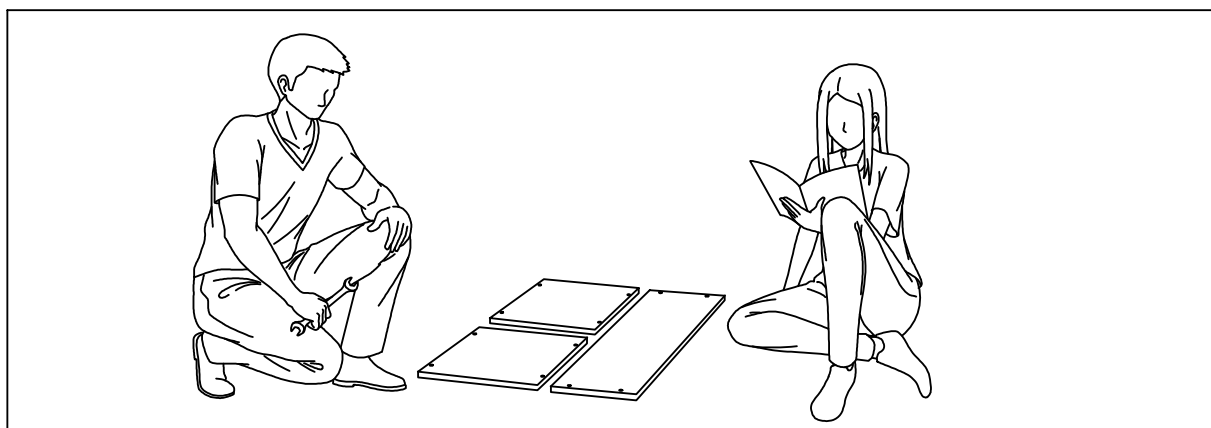

This furniture requires 2 people to assembly.  
Make sure no parts are missing or damaged before assembly.

# Not actual size

## ✓ CHECK ALL PARTS

Are you missing anything?

Double-check that all parts, hardware, and accessories listed on Pages 3-6 are accounted for. We can send any missing parts.

Should we send any replacements?

If there are any flaws in the parts, we can send replacements!

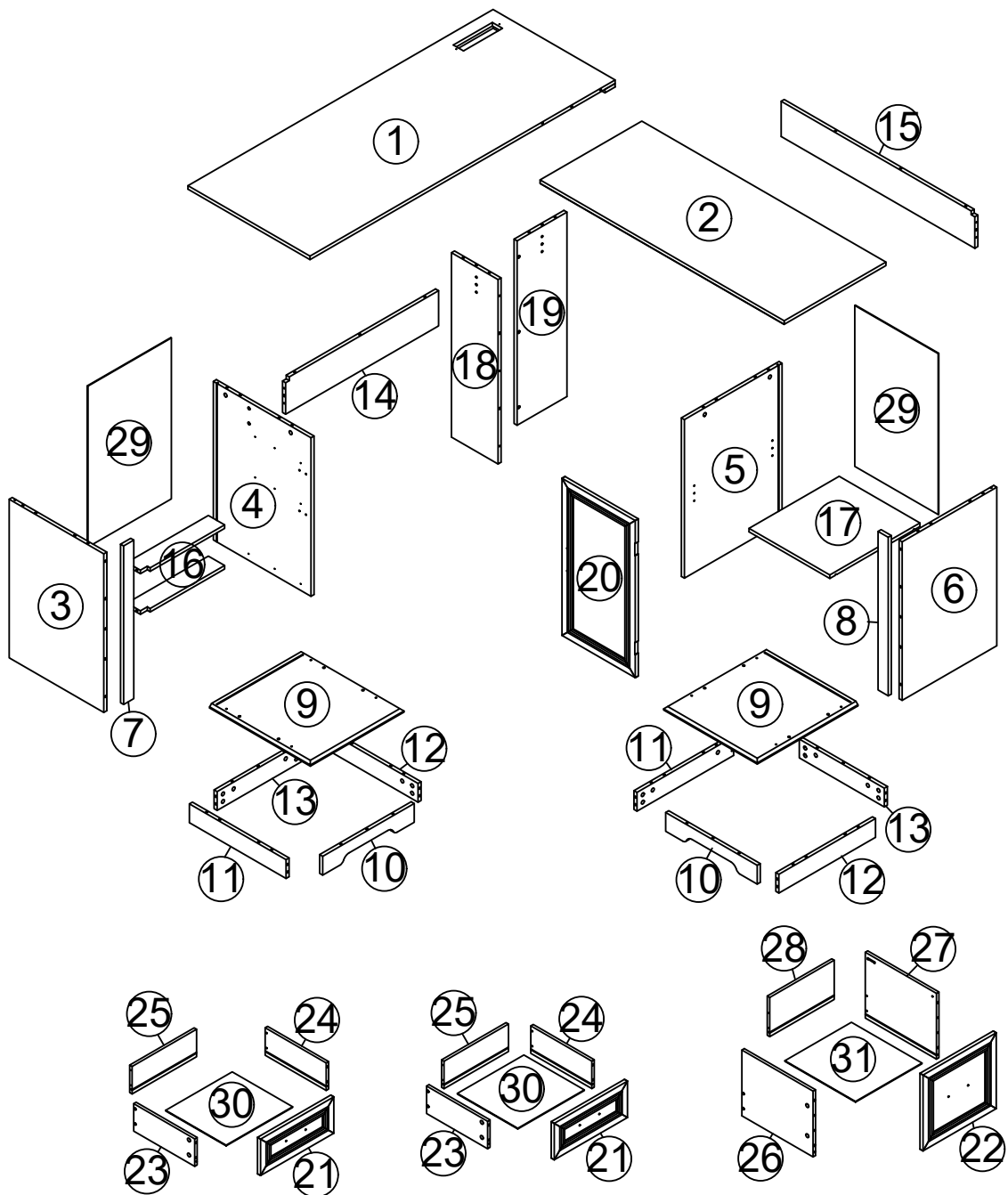

Not actual size

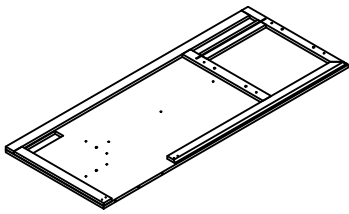

① X1

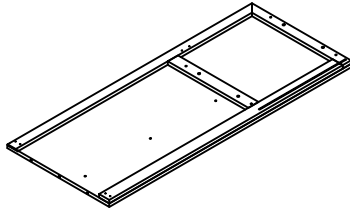

② X1

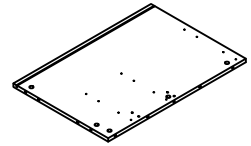

③ X1

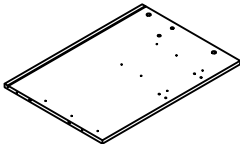

④ X1

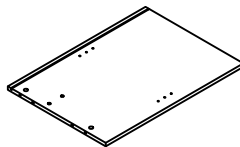

⑤ X1

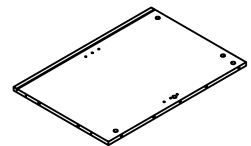

⑥ X1

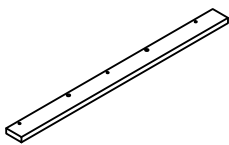

⑦ X1

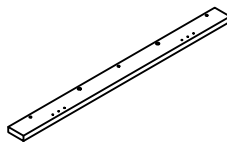

⑧ X1

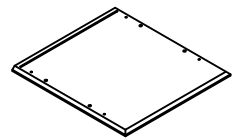

⑨ X2

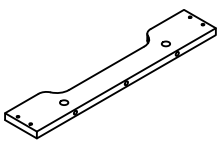

⑩ X2

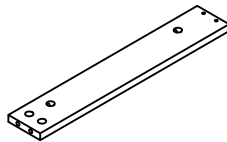

⑪ X2

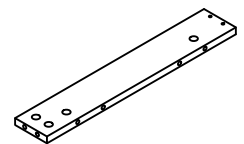

⑫ X2

Not actual size

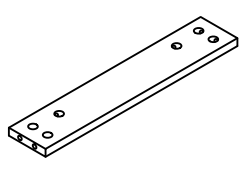

⑬X2

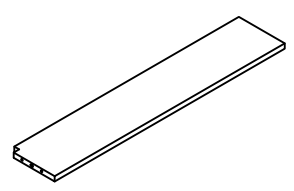

⑭X1

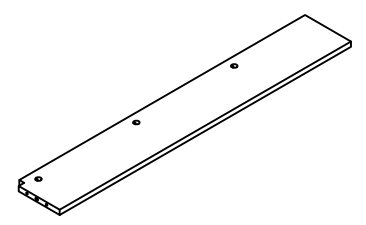

⑮X1

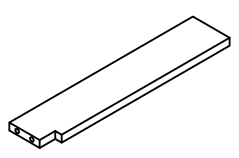

⑯X2

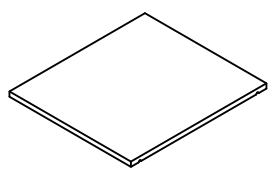

⑰X1

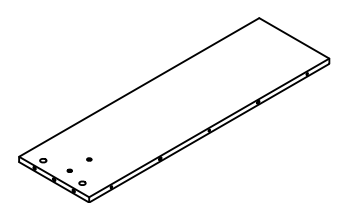

⑱X1

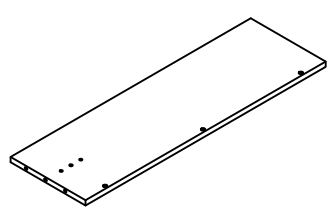

⑲X1

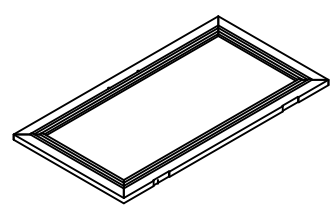

⑳X1

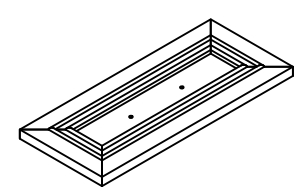

㉑X2

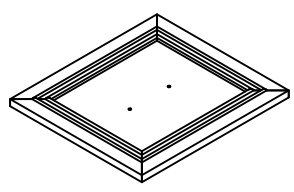

㉒X1

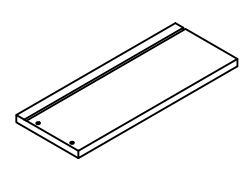

㉓X2

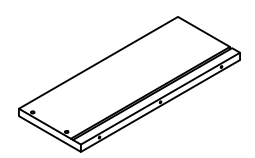

㉔X2

Not actual size

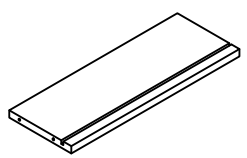

25 X2

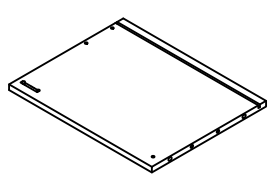

26 X1

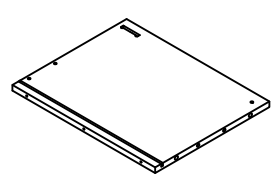

27 X1

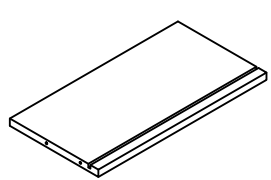

28 X1

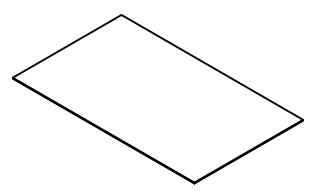

29 X2

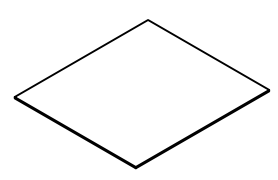

30 X2

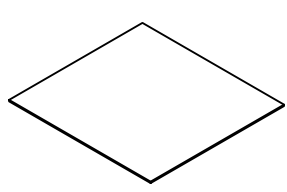

31 X1

## Not actual size

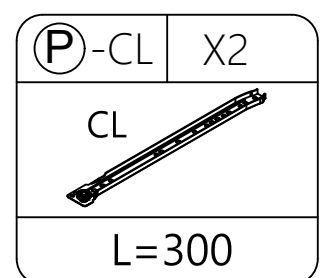
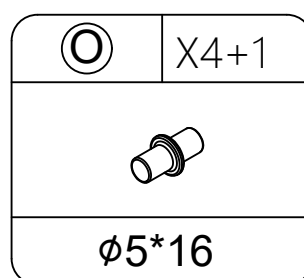
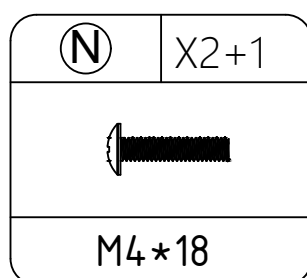
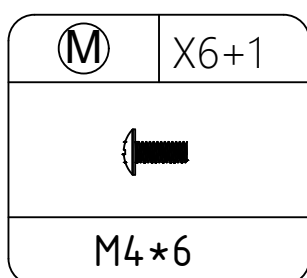
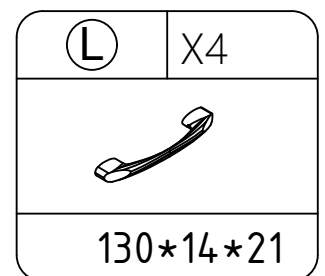
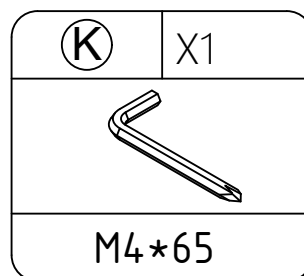
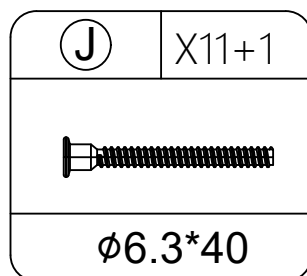
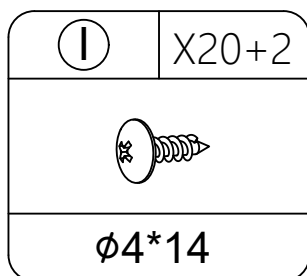
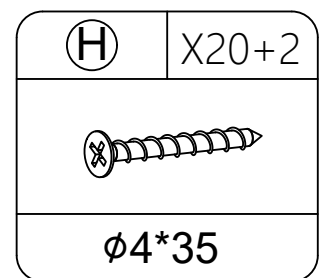
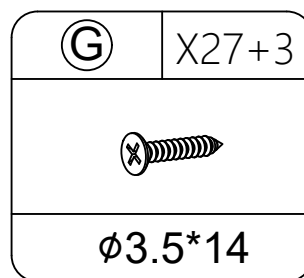
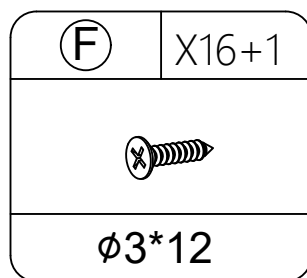
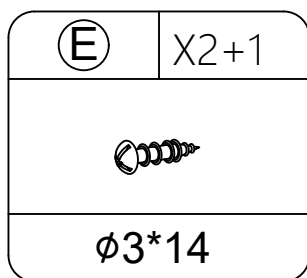
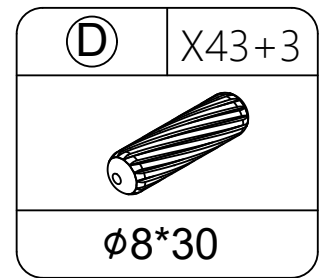
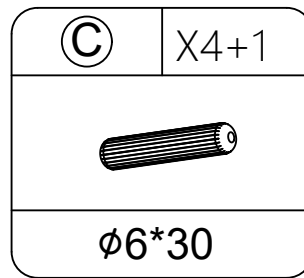
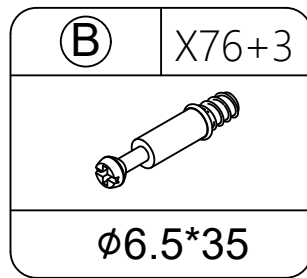
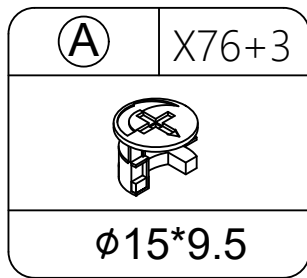

# Not actual size

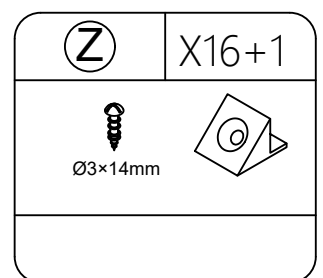
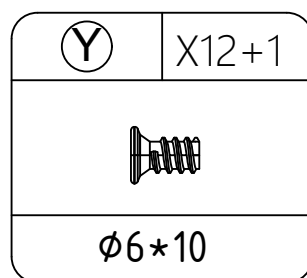
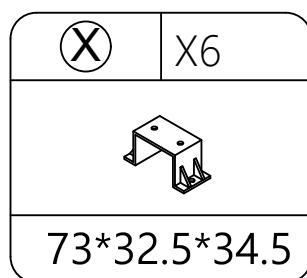
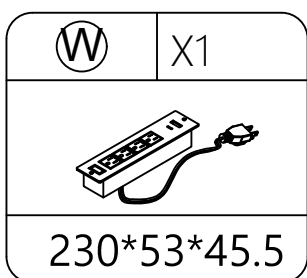
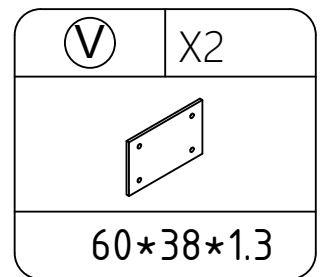
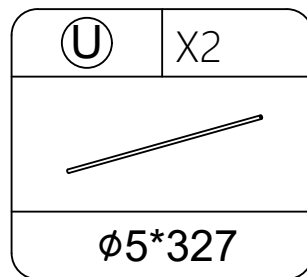
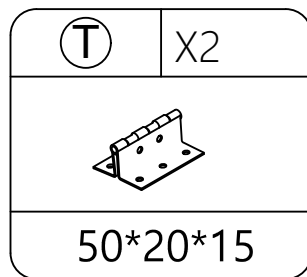
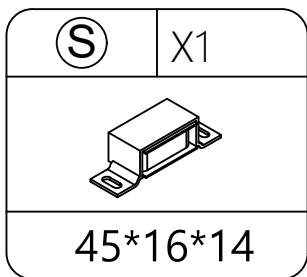
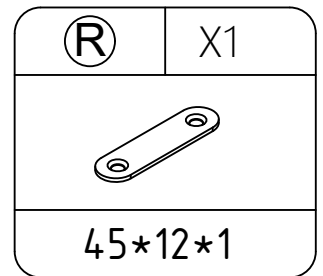
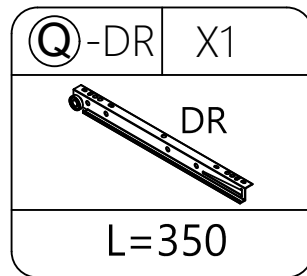
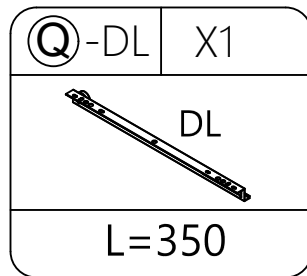
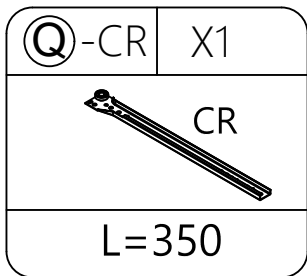
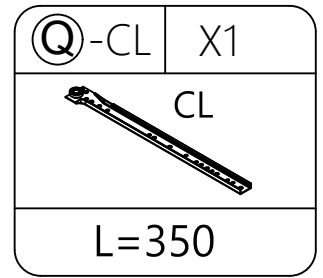
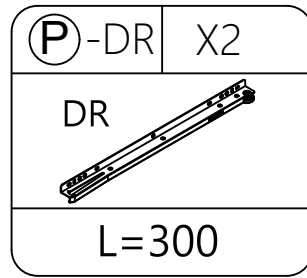
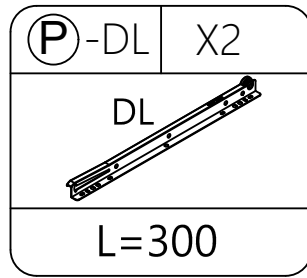
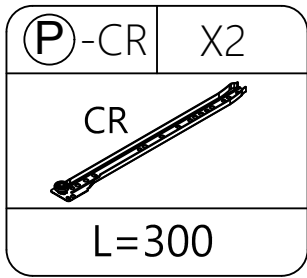

Not actual size

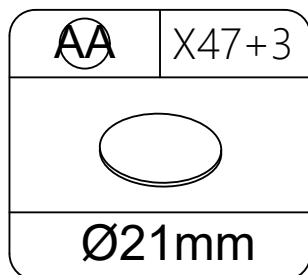

## Cam Lock Fastening System

Insert the cam bolt into the hole first, then insert the cam lock and lock it.

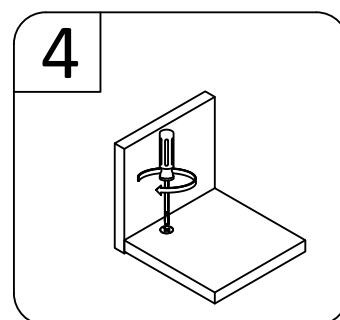
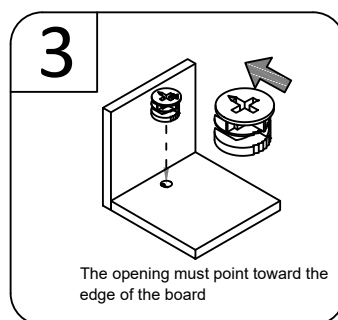
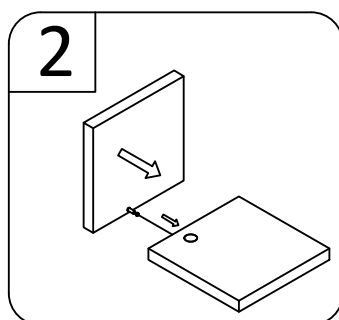
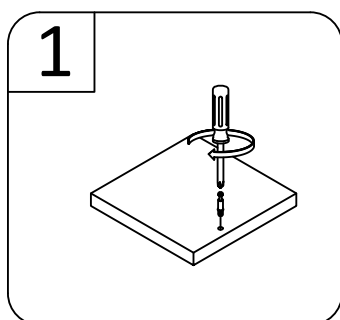

# STEP 1

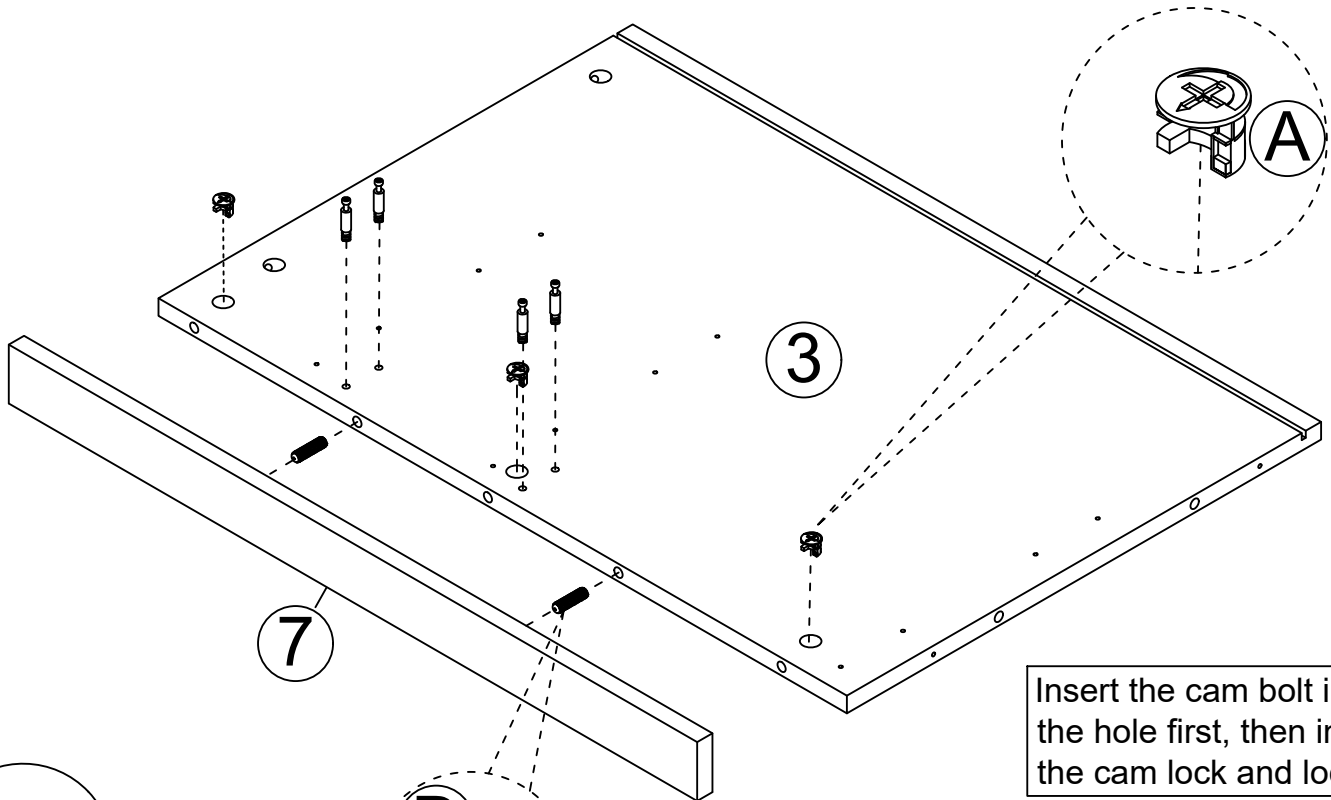
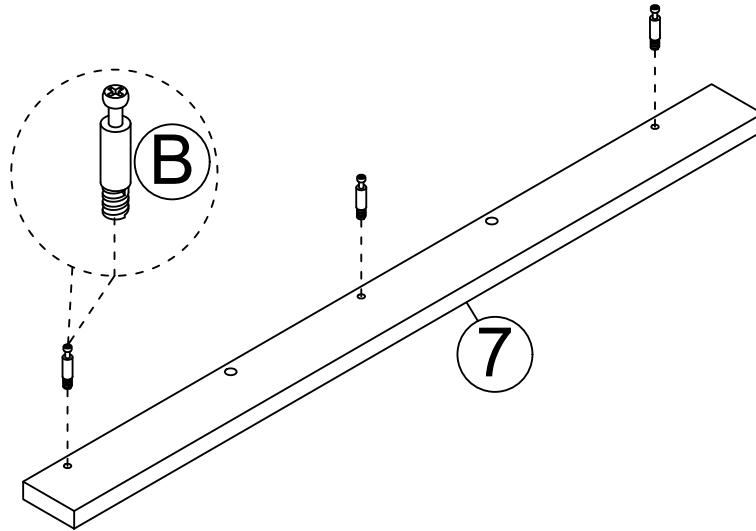
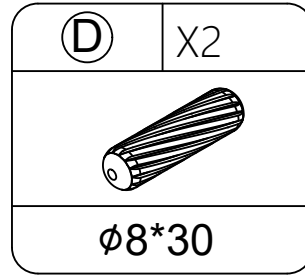
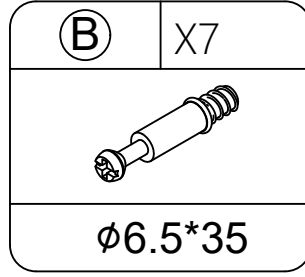
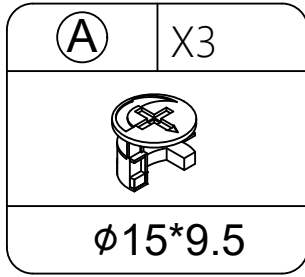
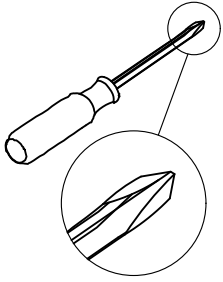

Insert the cam bolt into the hole first, then insert the cam lock and lock it.

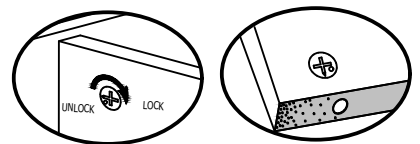
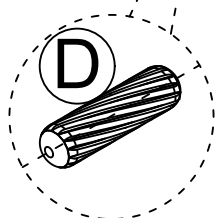
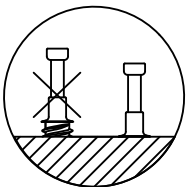

Proper orientation of CAM LOCK

# STEP 2

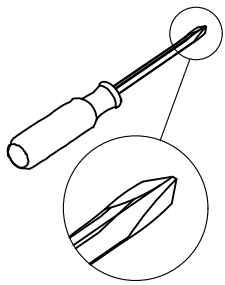

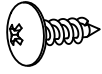
⊃	X12
	
ø4*14	

⊗	X6
	
73*32.5*34.5	

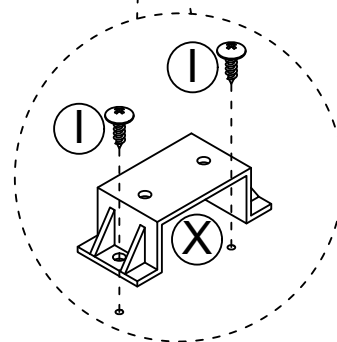
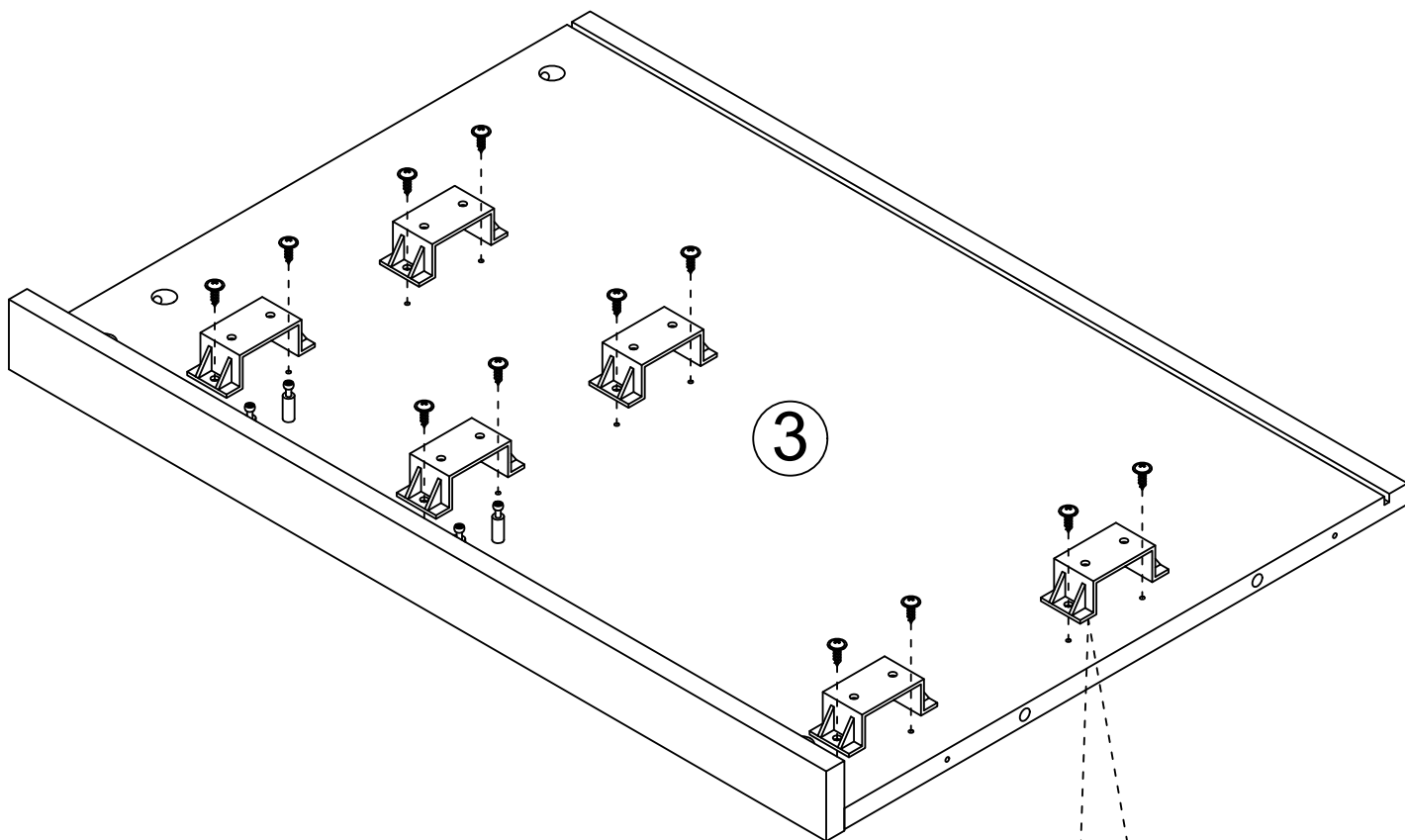

# STEP 3

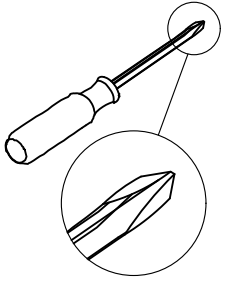

(P)-CL	X2
CL	
L=300	

(Q)-CL	X1
CL	
L=350	

(Y)	X12
φ6×10	

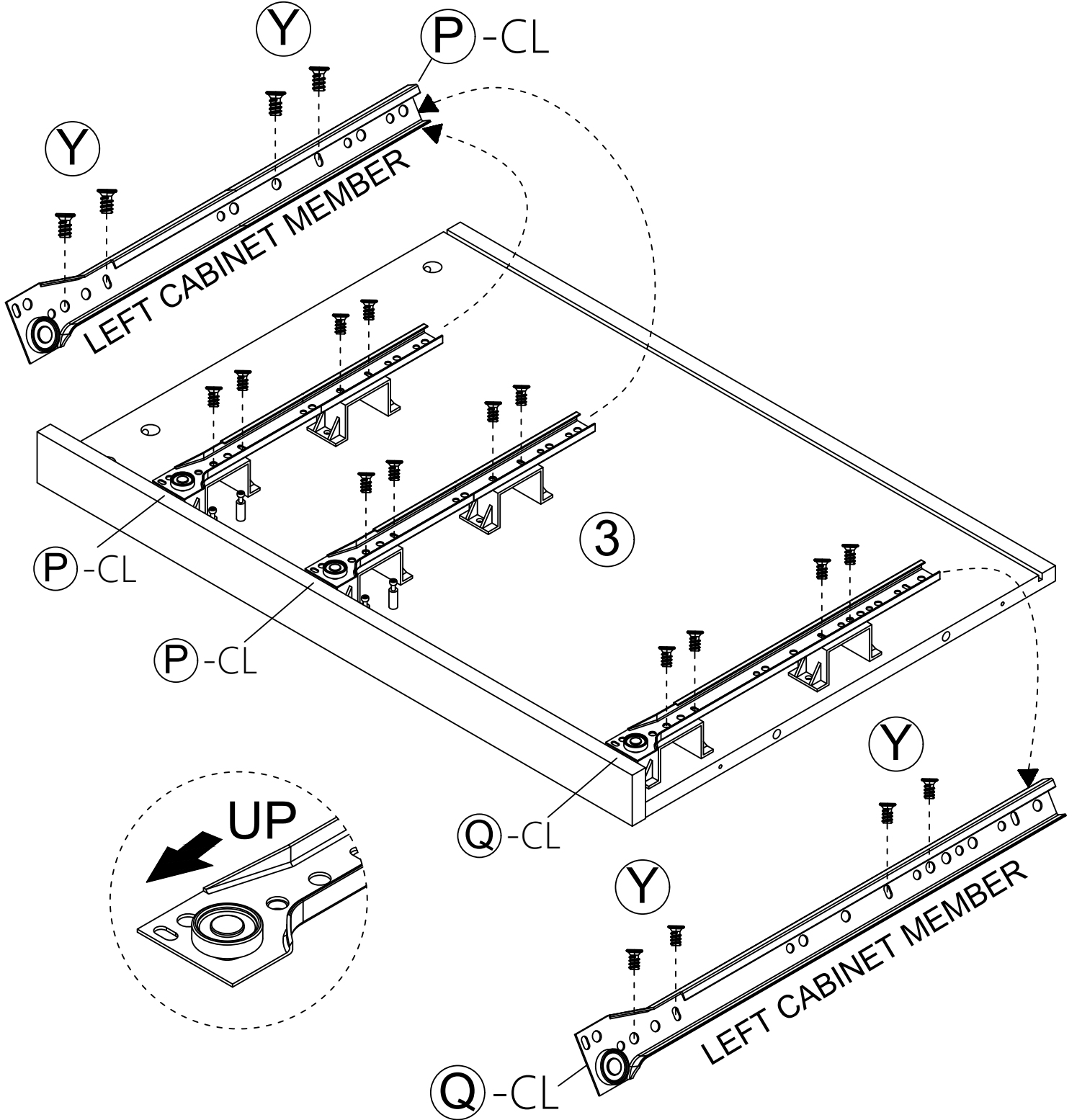

# STEP 4

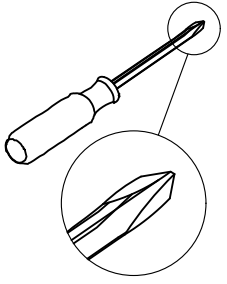

<b>B</b>	X4
ø6.5*35	

<b>G</b>	X9
ø3.5*14	

<b>P-CR</b>	X2
CR 	
L=300	

<b>Q-CR</b>	X1
CR 	
L=350	

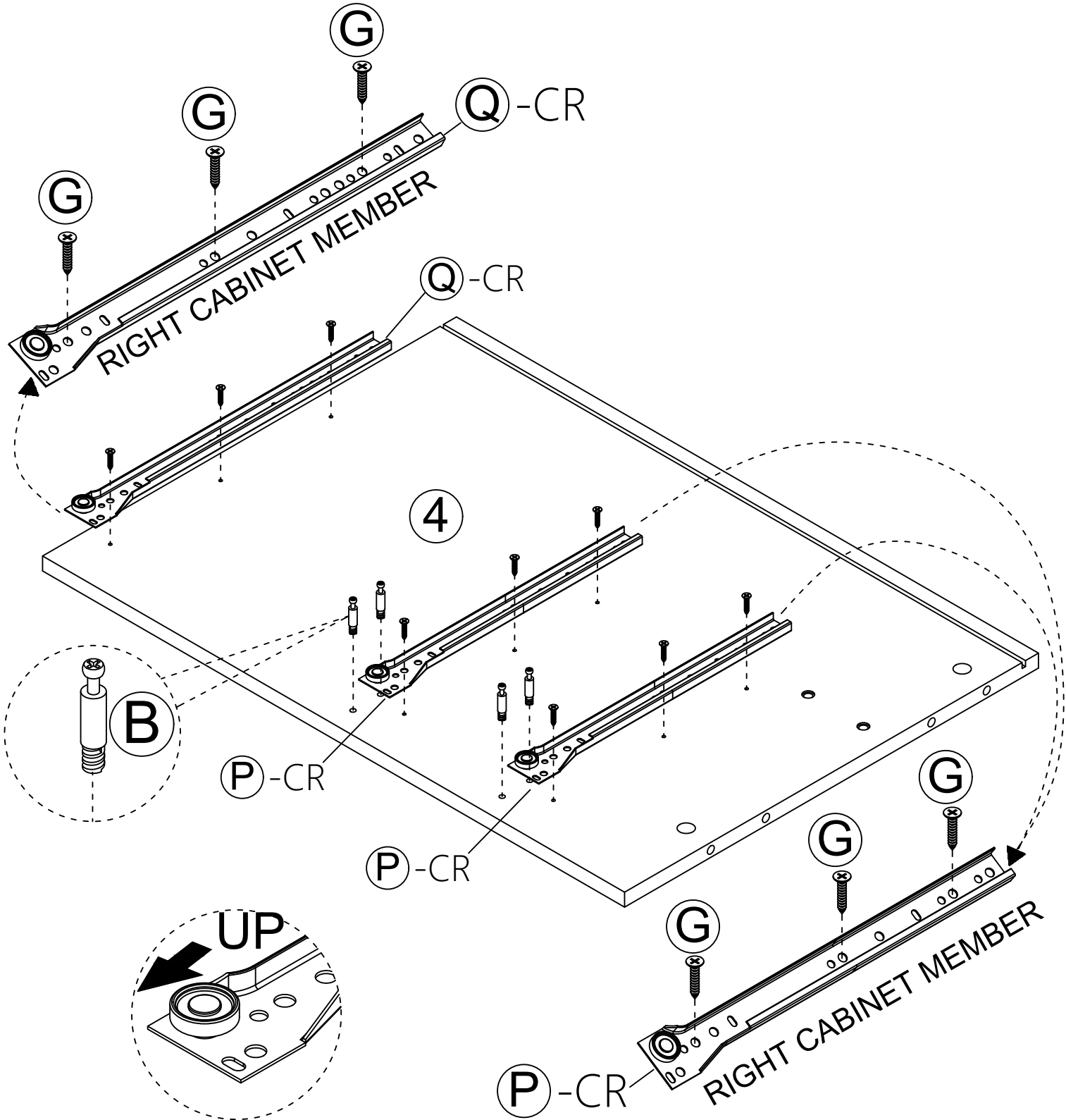

# STEP 5

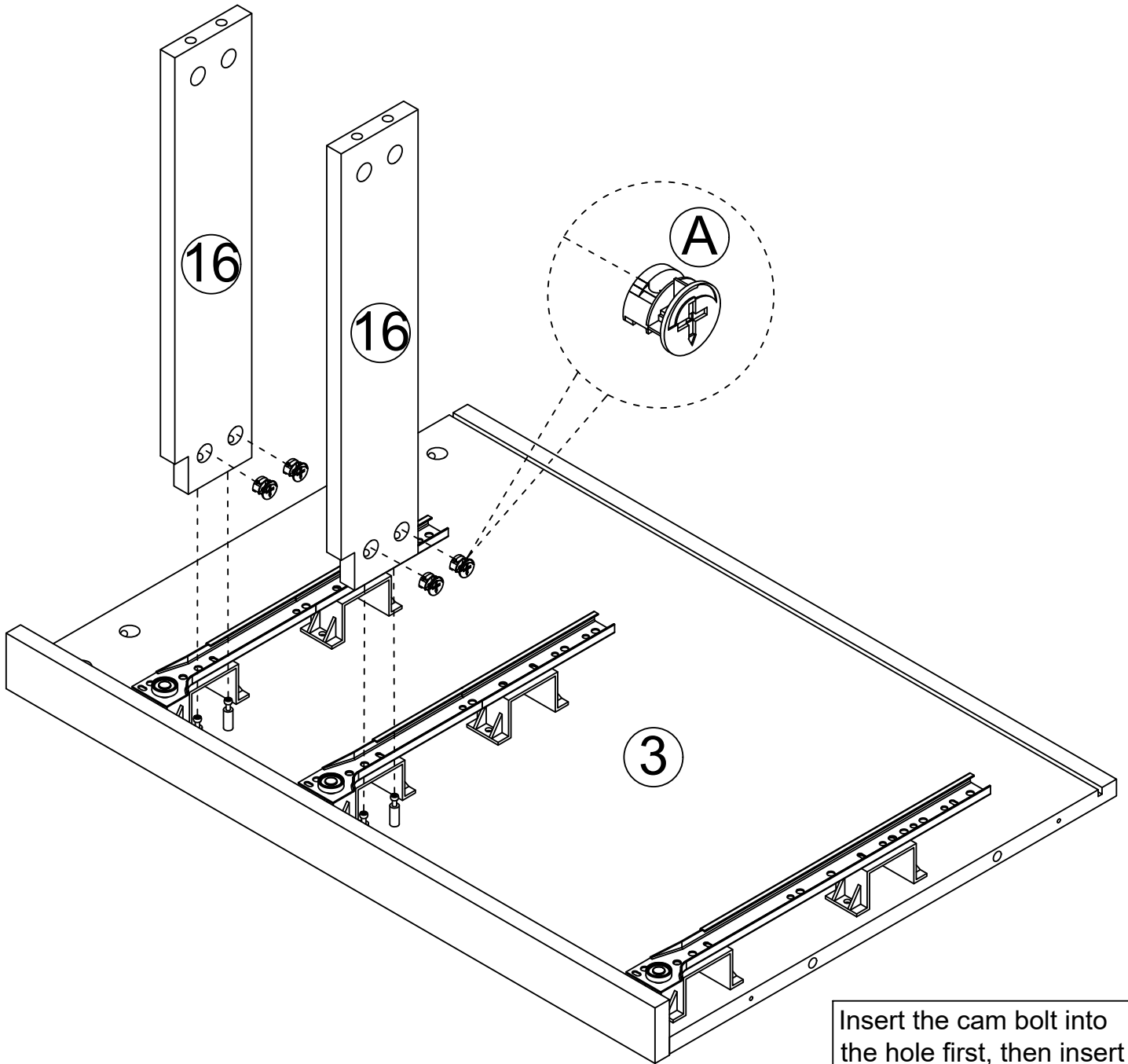
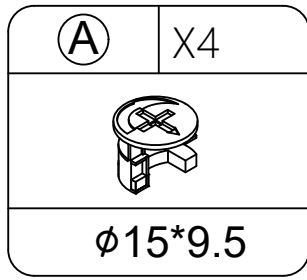
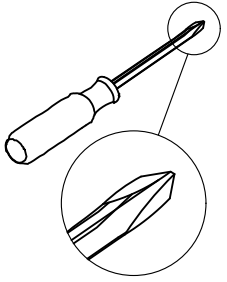

Insert the cam bolt into the hole first, then insert the cam lock and lock it.

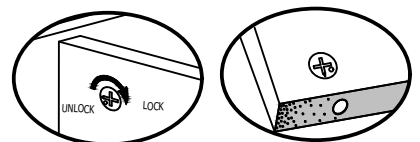

# STEP 6

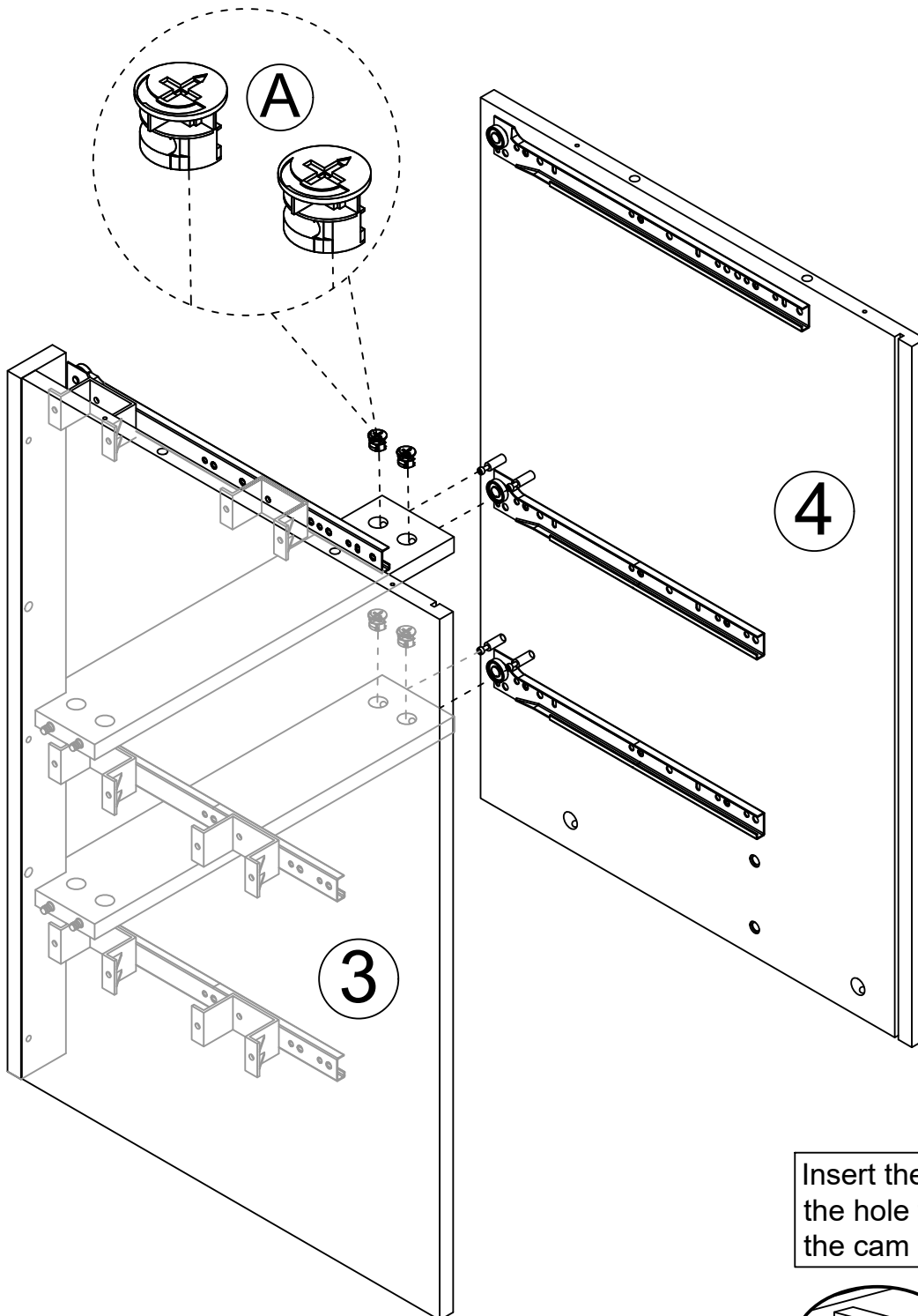
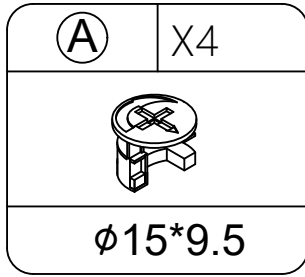
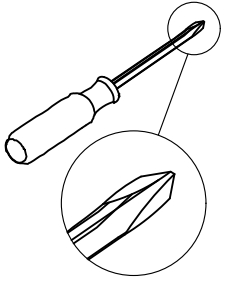

Insert the cam bolt into the hole first, then insert the cam lock and lock it.

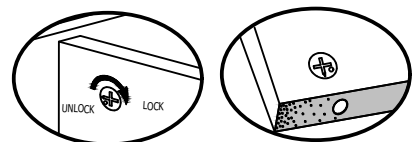

Proper orientation of CAM LOCK

# STEP 7

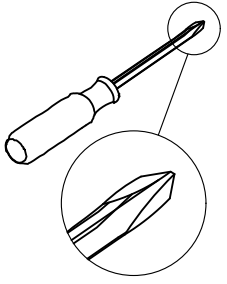

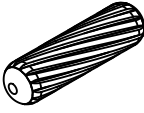
ⓓ	X4
	
ϕ8*30	

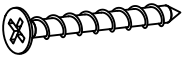
ⓓ	X4
	
ϕ4*35	

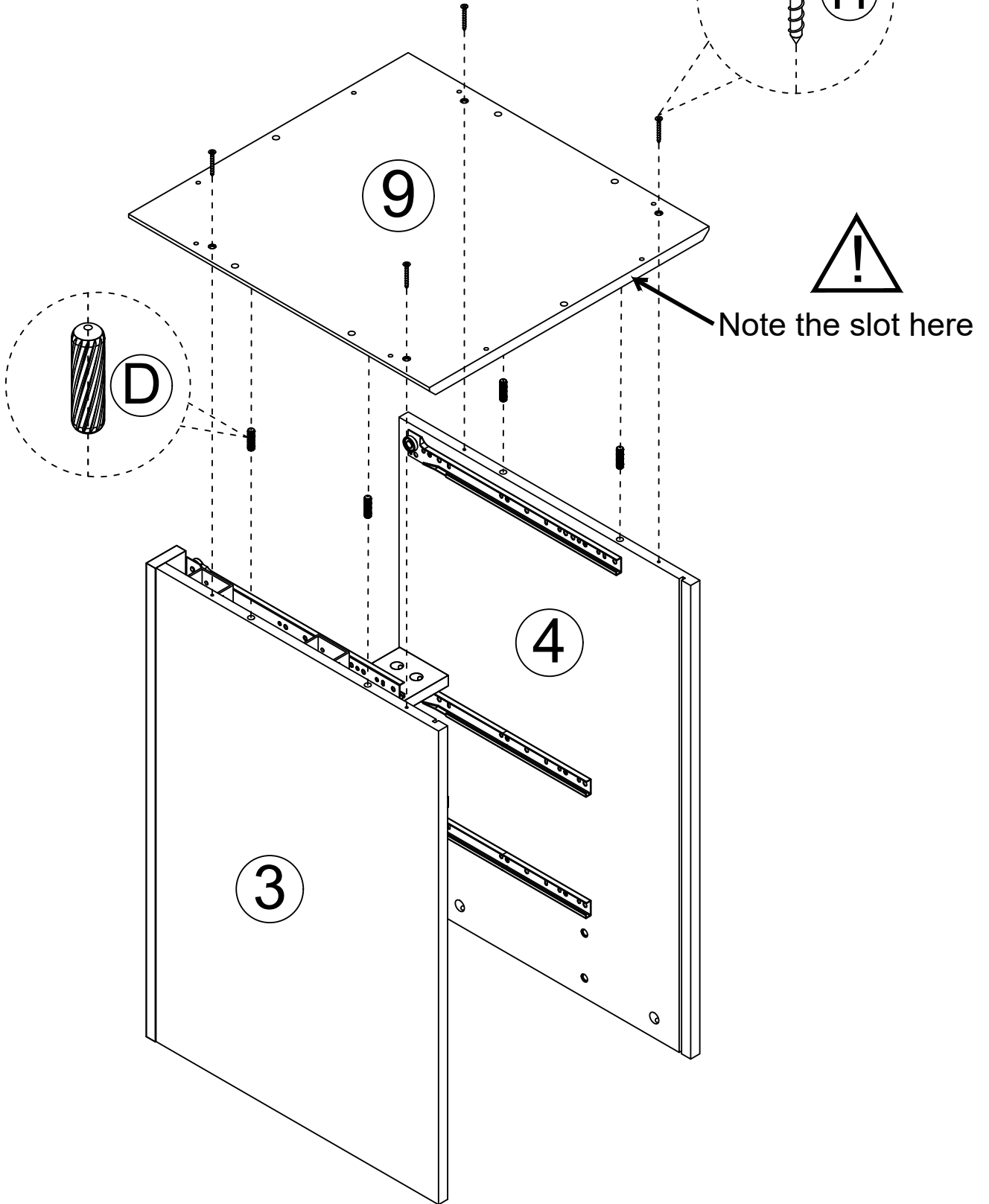

# STEP 8

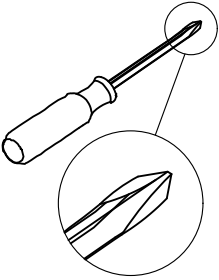

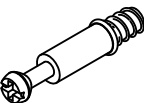
(B)	X8
	
ø6.5*35	

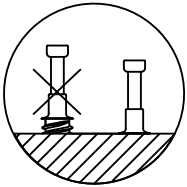
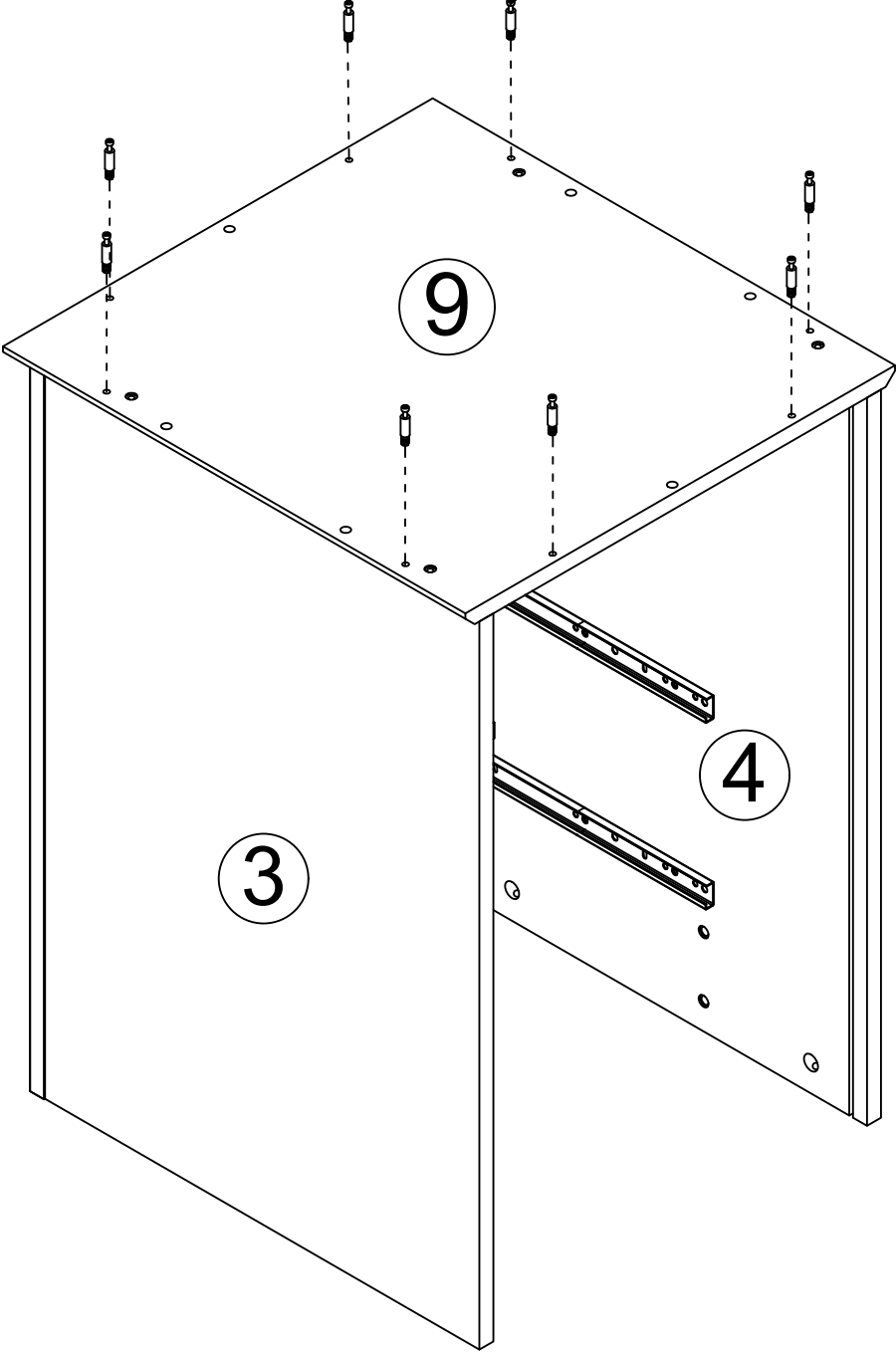
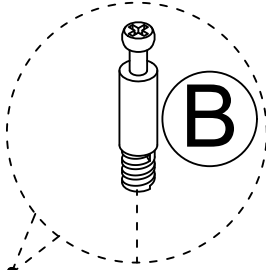

# STEP 9

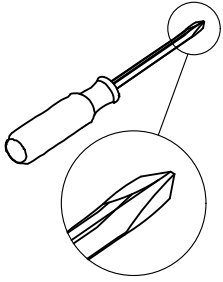

<b>A</b>	X8
$\phi 15 \times 9.5$	

<b>B</b>	X16
$\phi 6.5 \times 35$	

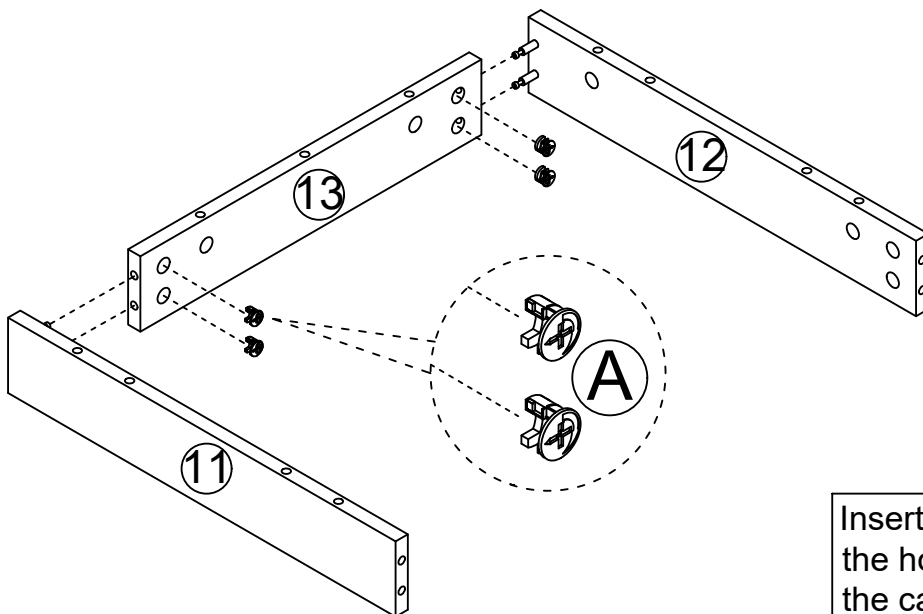
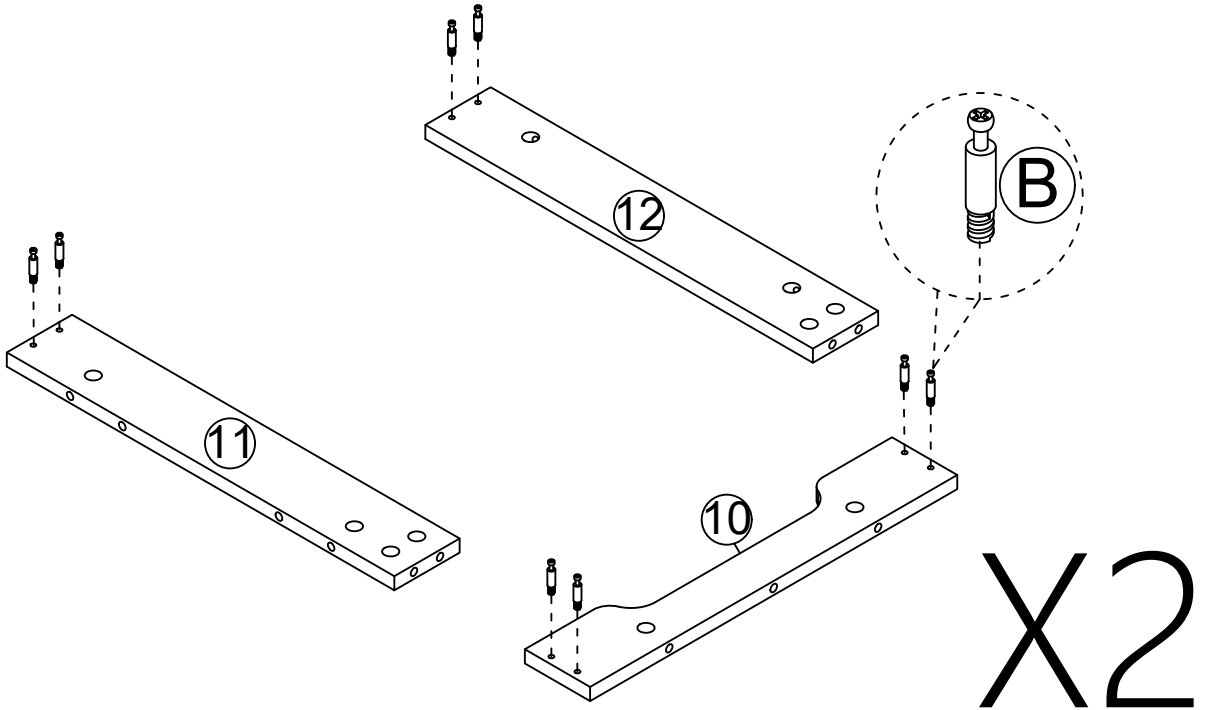

Insert the cam bolt into the hole first, then insert the cam lock and lock it.

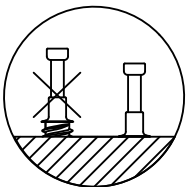

# X2

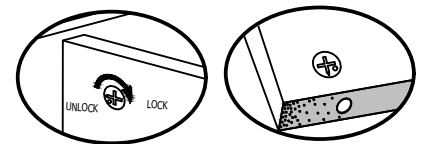

Proper orientation of CAM LOCK

# STEP 10

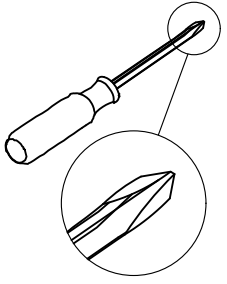

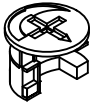
A	X8
	
Ø15*9.5	

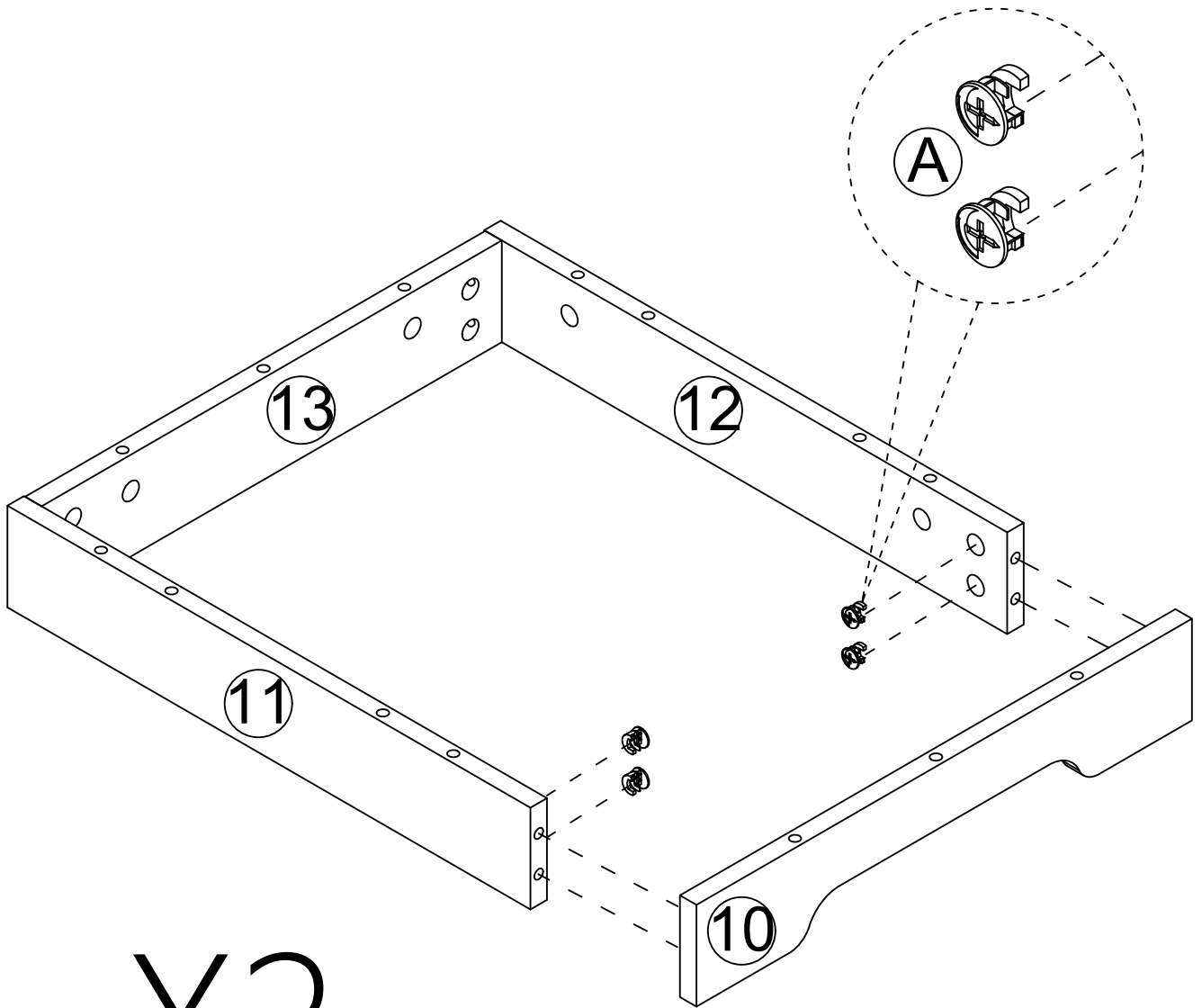

X2

Insert the cam bolt into the hole first, then insert the cam lock and lock it.

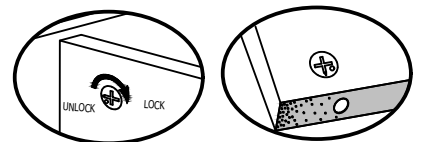

Proper orientation of CAM LOCK

# STEP 11

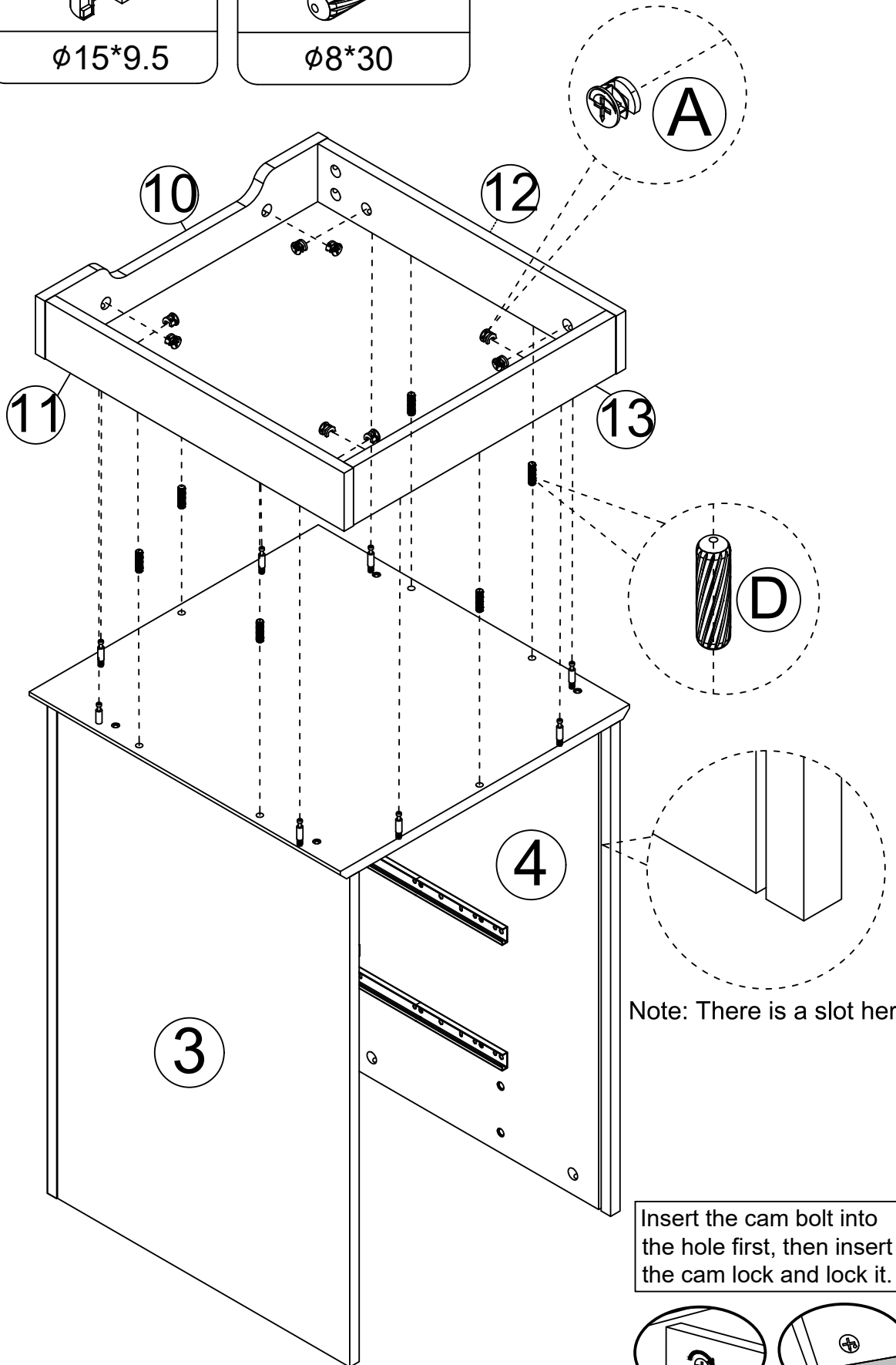
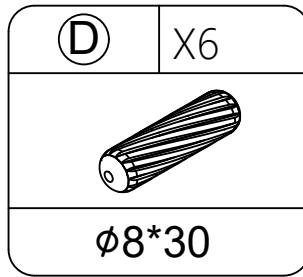
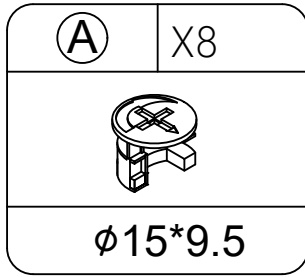
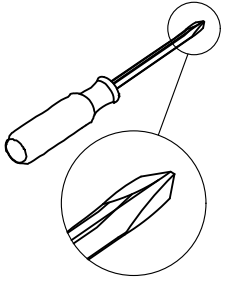

Note: There is a slot here.

Insert the cam bolt into the hole first, then insert the cam lock and lock it.

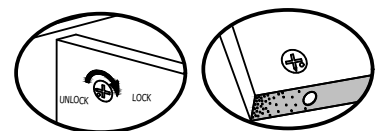

Proper orientation of CAM LOCK

# STEP 12

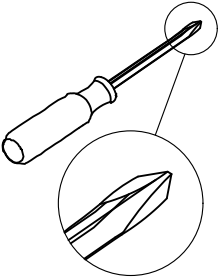

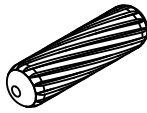
ⓓ	X2
	
ø8*30	

ⓙ	X3
	
ø6.3*40	

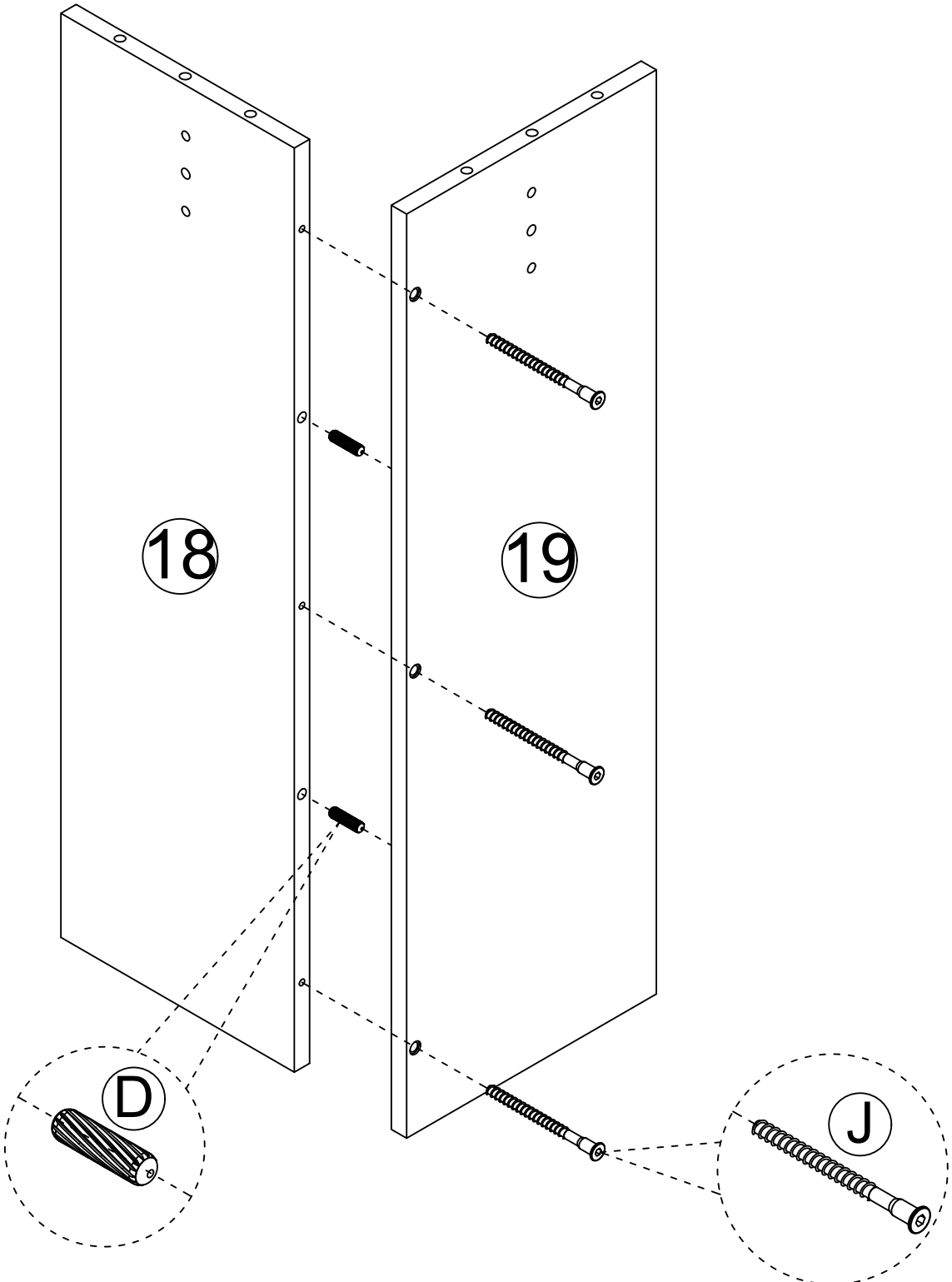

# STEP 13

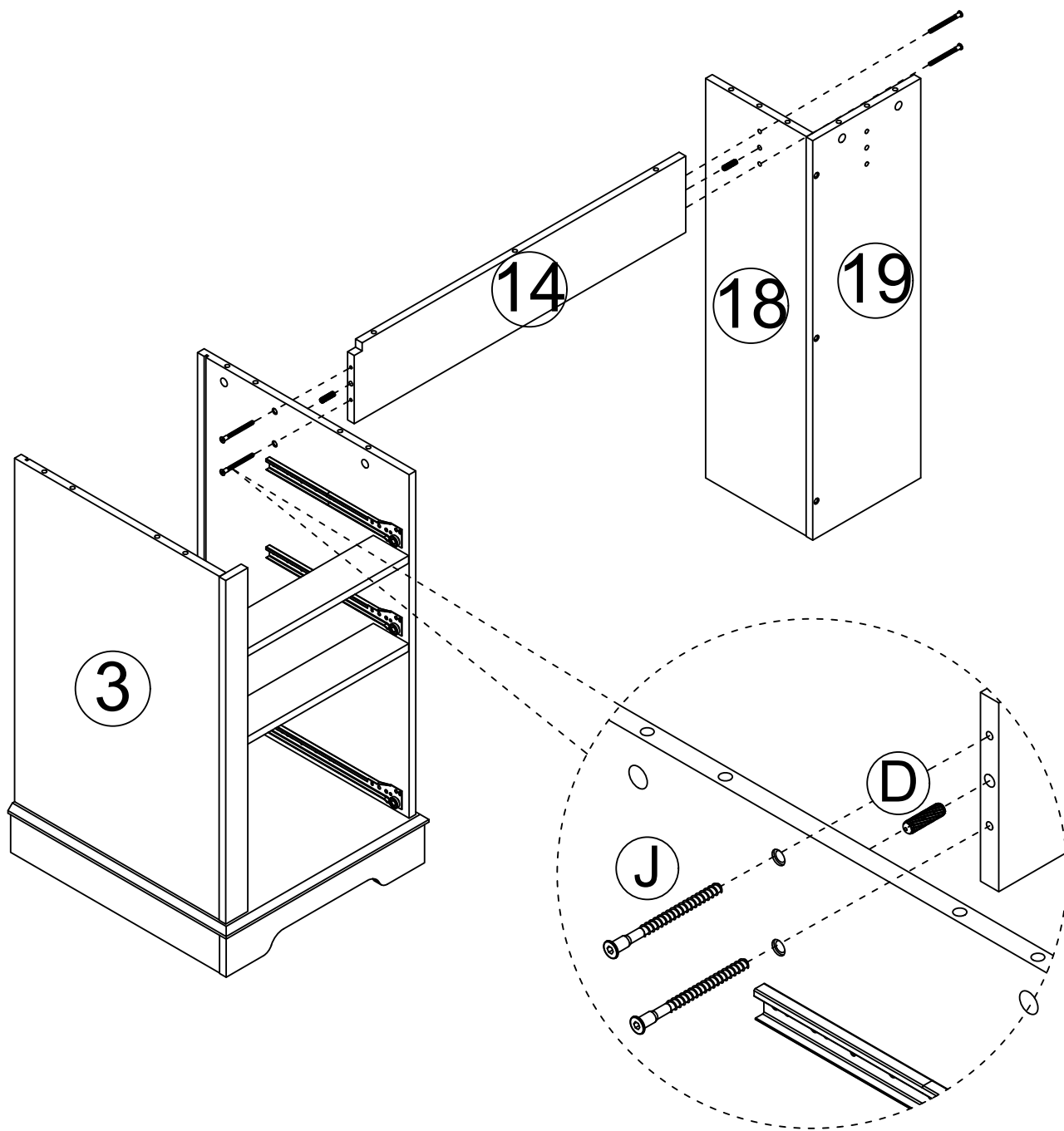
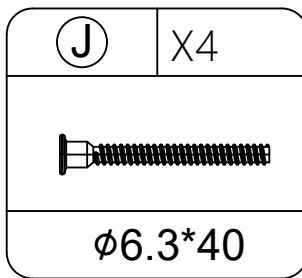
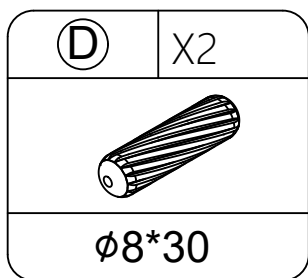
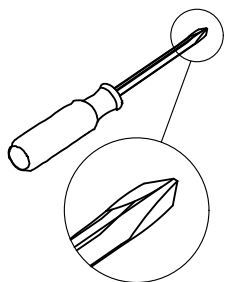

# STEP 14

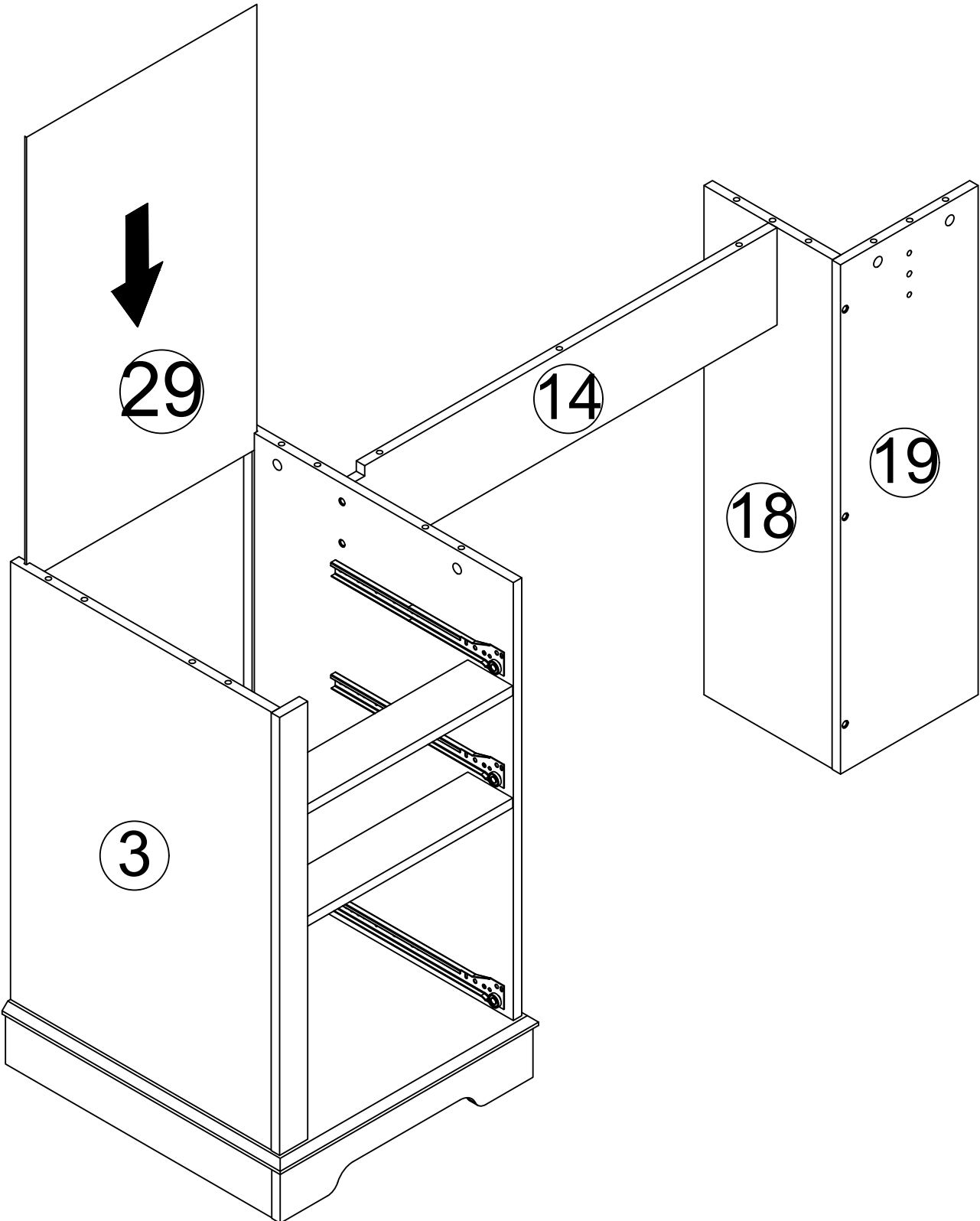
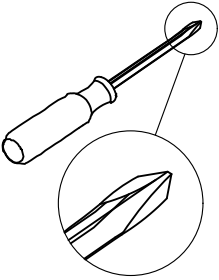

# STEP 15

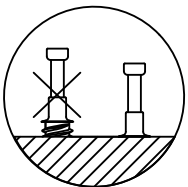
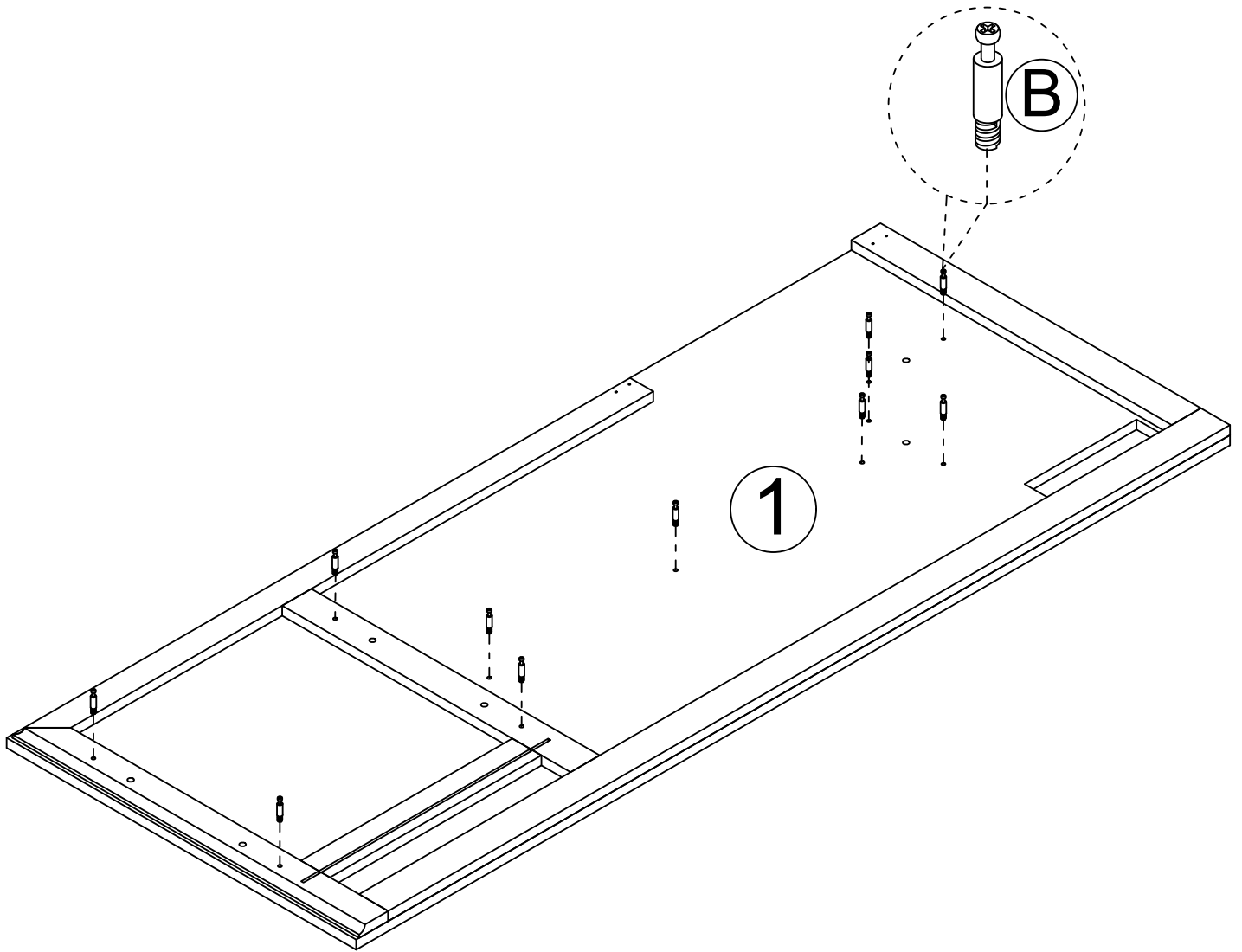
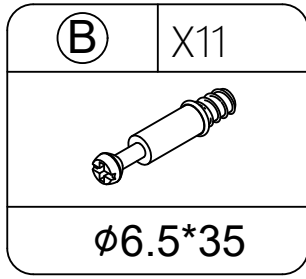
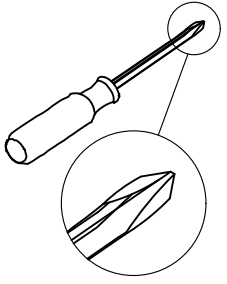

# STEP 16

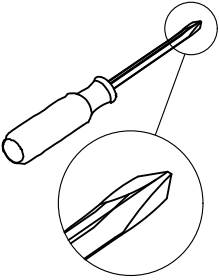

(A)	X11
	
ø15*9.5	

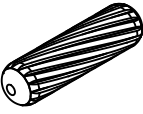
(D)	X6
	
ø8*30	

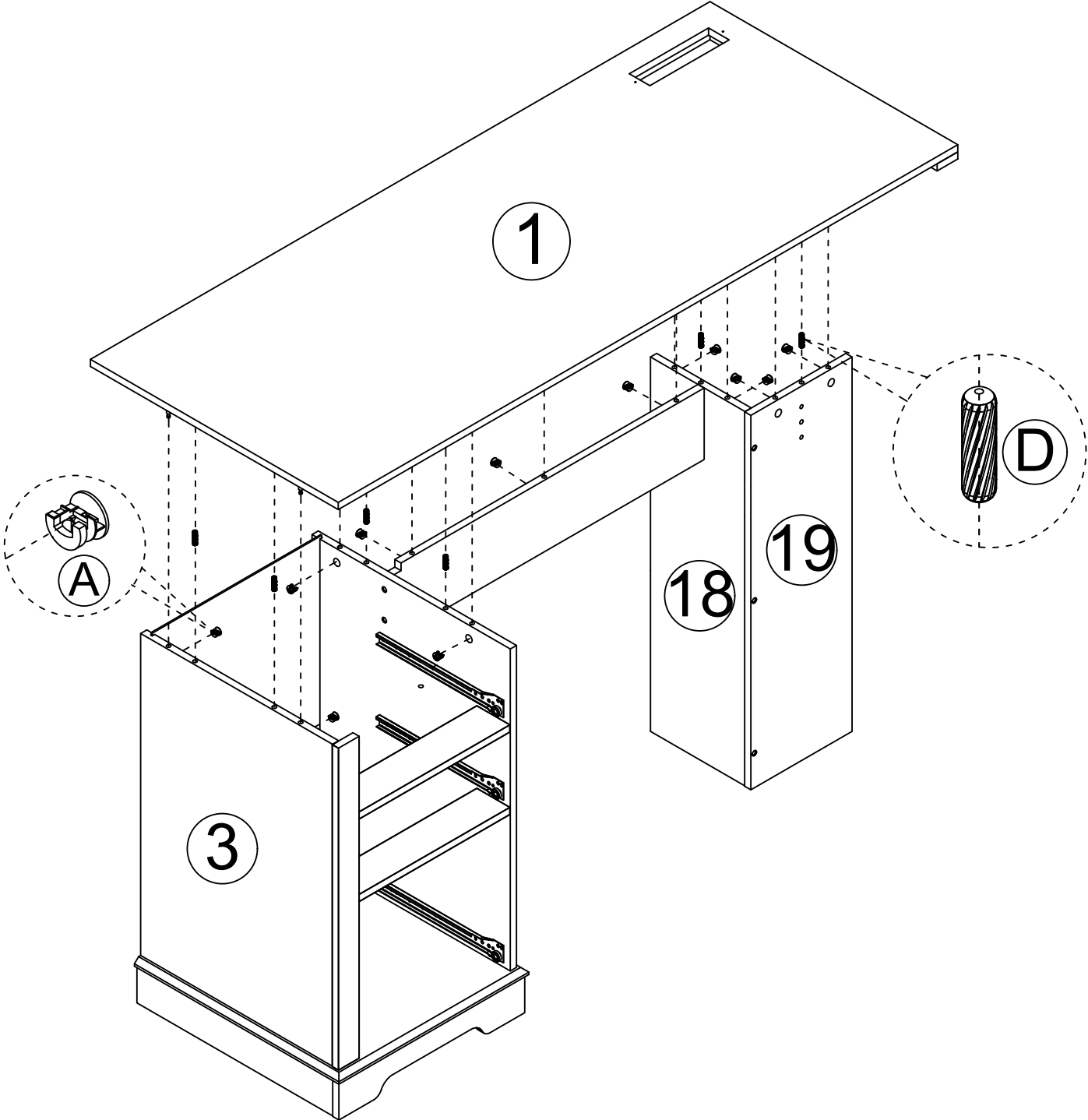

# STEP 17

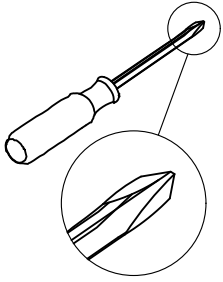

(A)	X3
ø15*9.5	

(B)	X3
ø6.5*35	

(D)	X2
ø8*30	

(F)	X6
ø3*12	

(T)	X2
50*20*15	

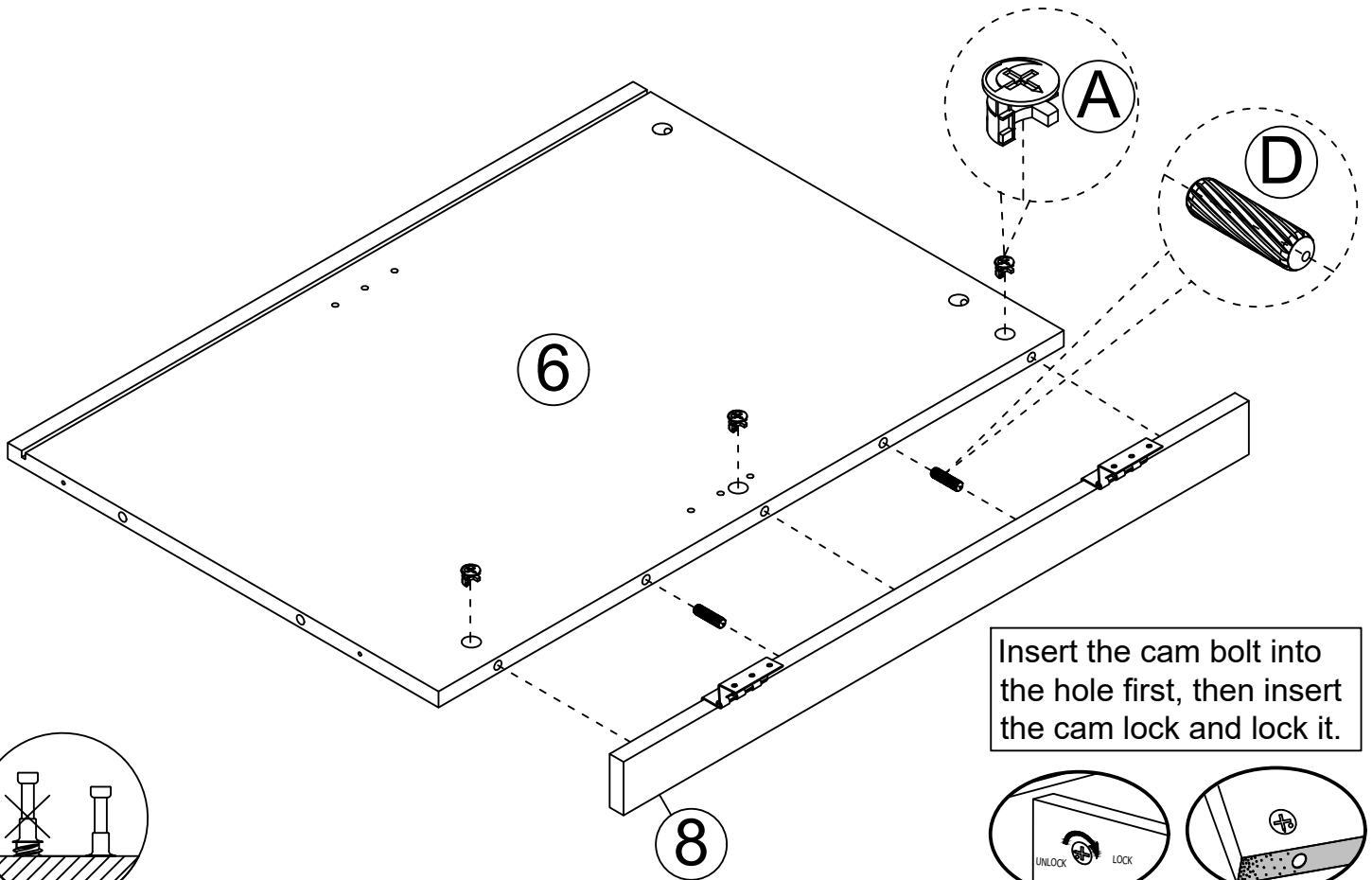
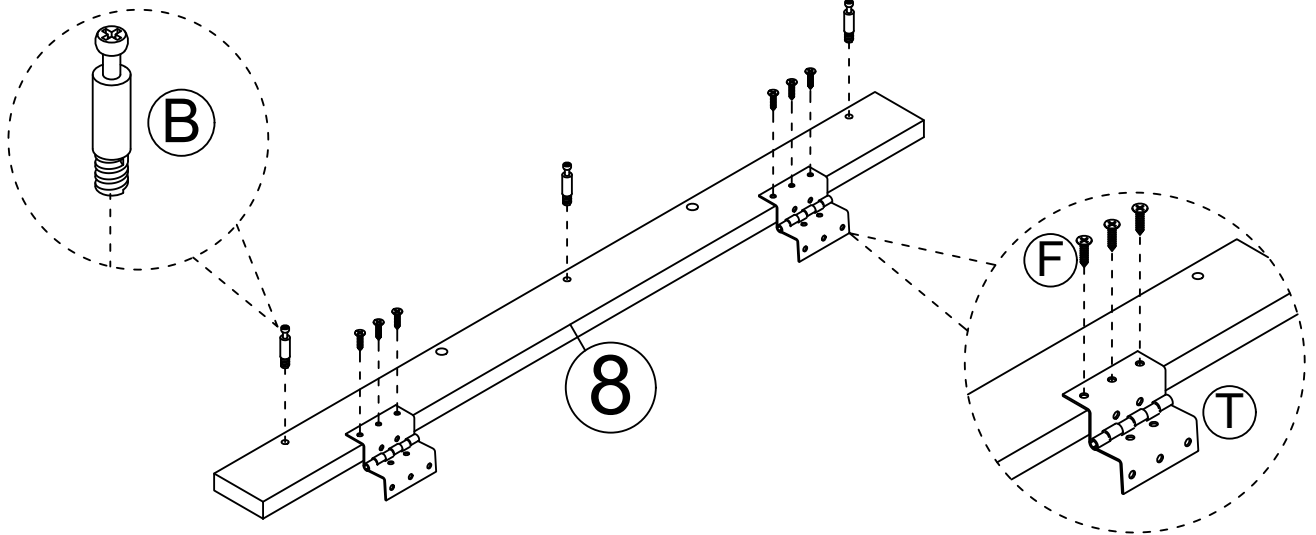

Insert the cam bolt into the hole first, then insert the cam lock and lock it.

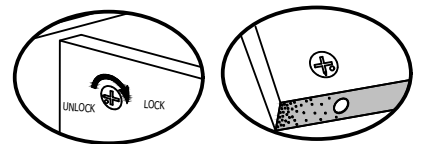
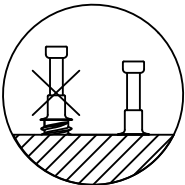

Proper orientation of CAM LOCK

# STEP 18

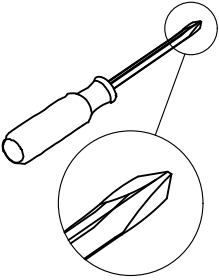

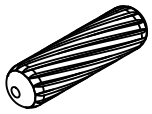
ⓓ	X1
	
ø8*30	

ⓙ	X2
	
ø6.3*40	



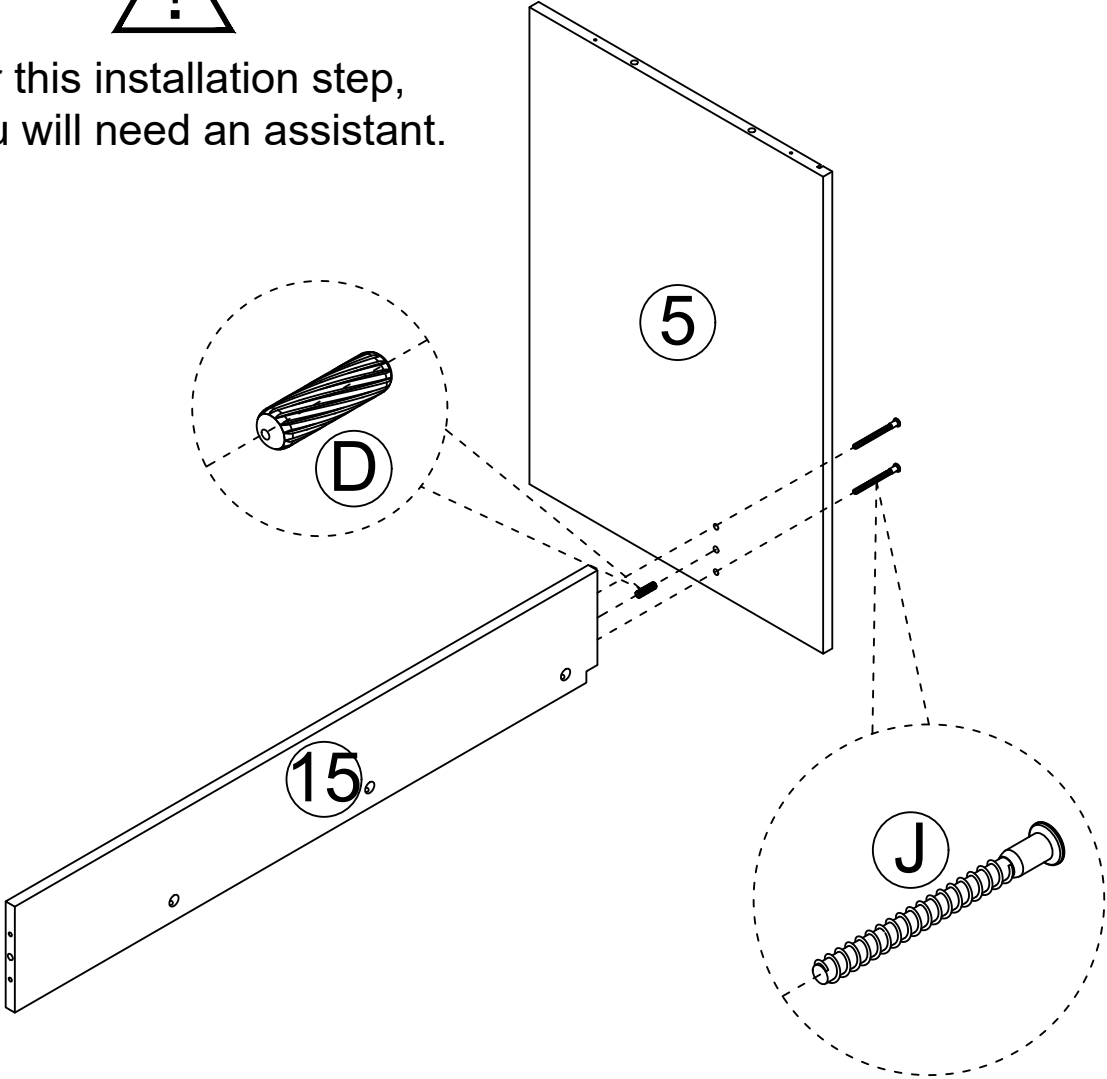

For this installation step,  
you will need an assistant.

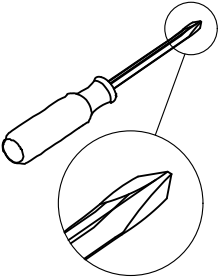

# STEP 19

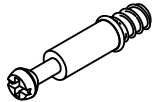

(B)	X7
	
ø6.5*35	

(E)	X2
	
ø3*14	

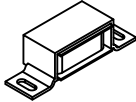
(S)	X1
	
45*16*14	

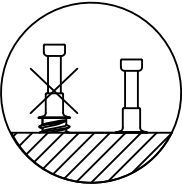
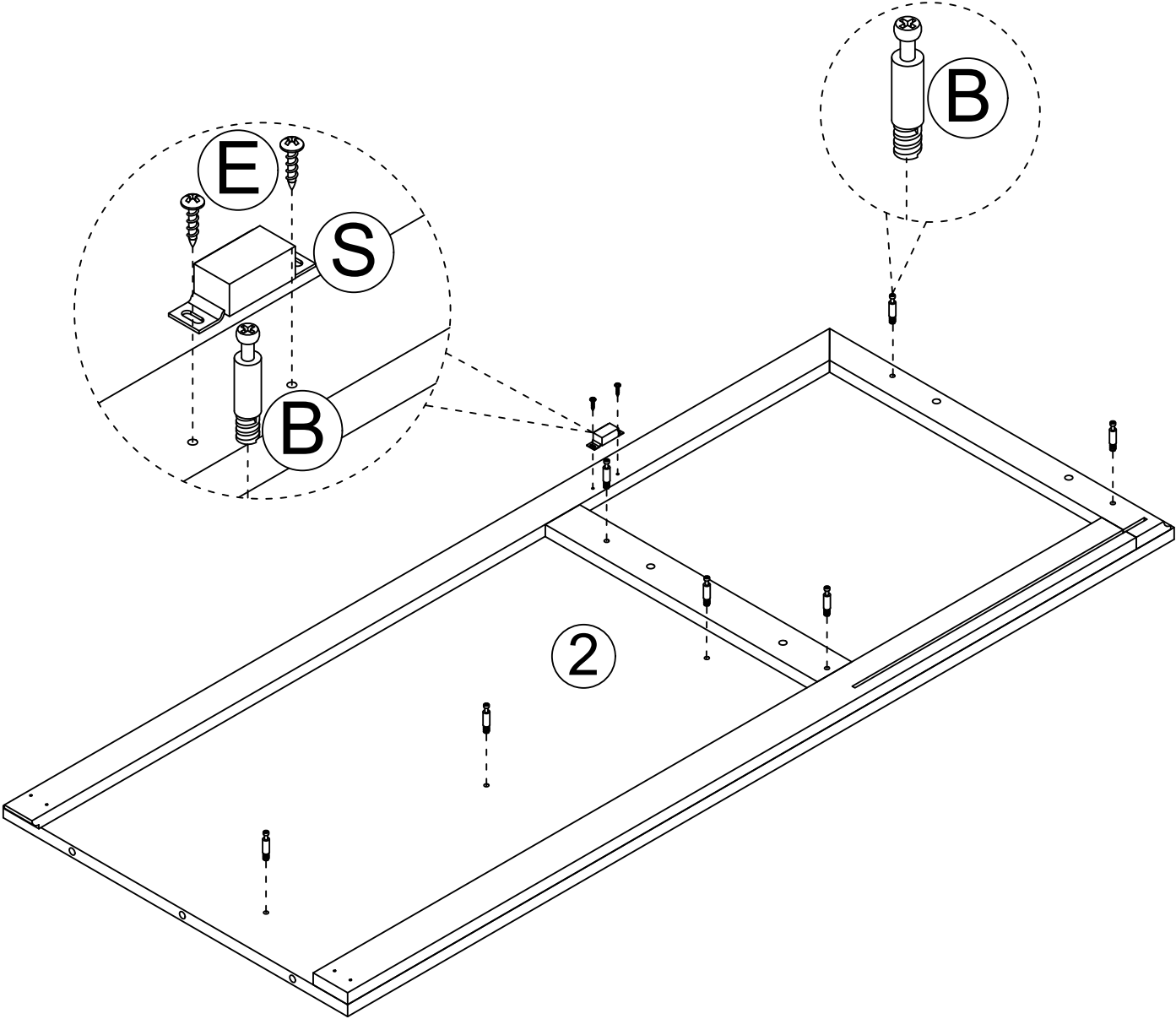

# STEP 20

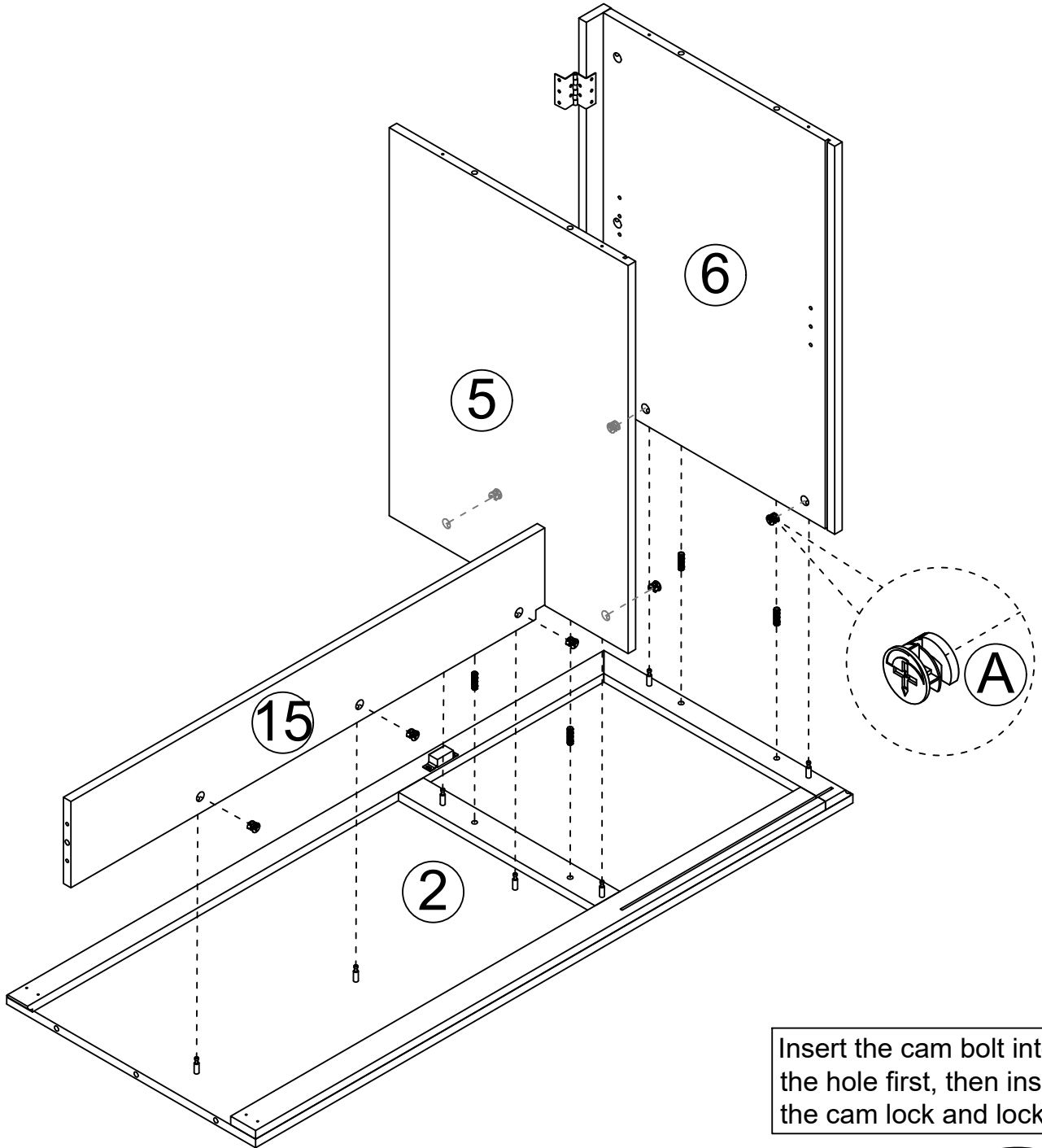
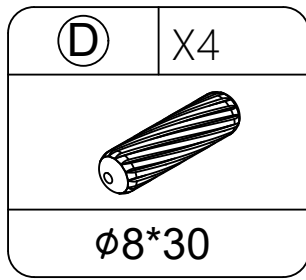
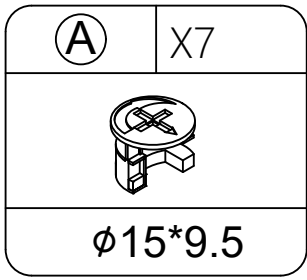
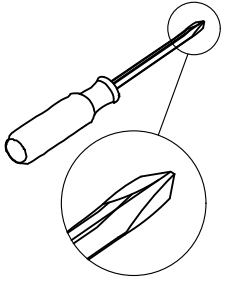

Insert the cam bolt into the hole first, then insert the cam lock and lock it.

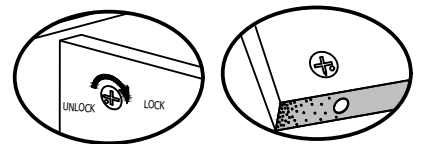

Proper orientation of CAM LOCK

# STEP 21

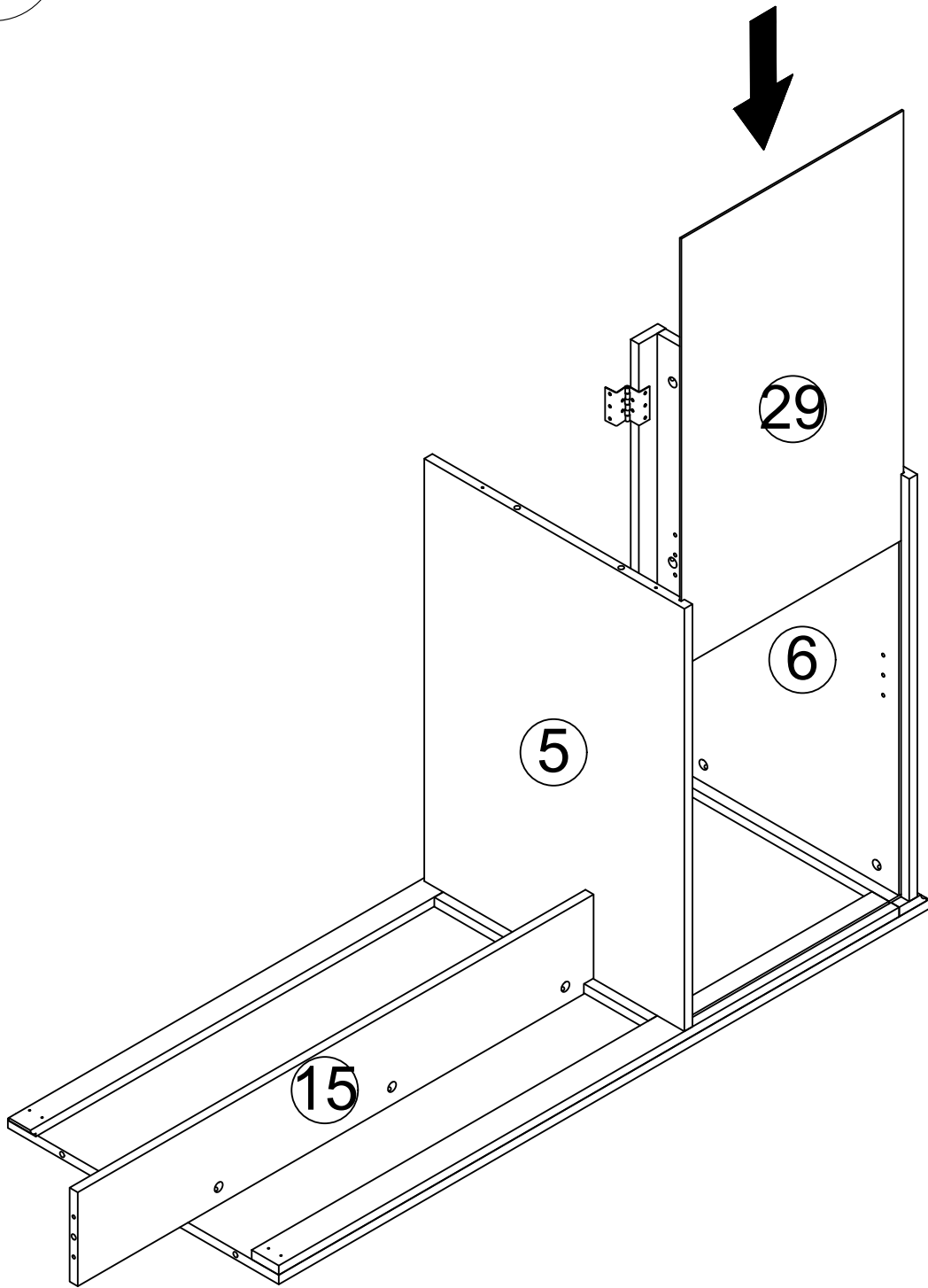
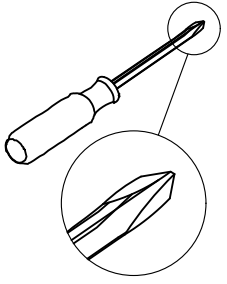

# STEP 22

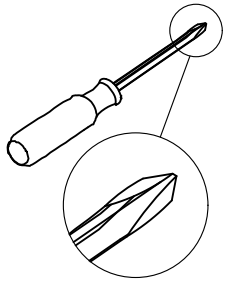

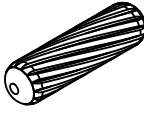
<b>D</b>	X4
	
$\phi 8 \times 30$	

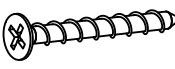
<b>H</b>	X4
	
$\phi 4 \times 35$	

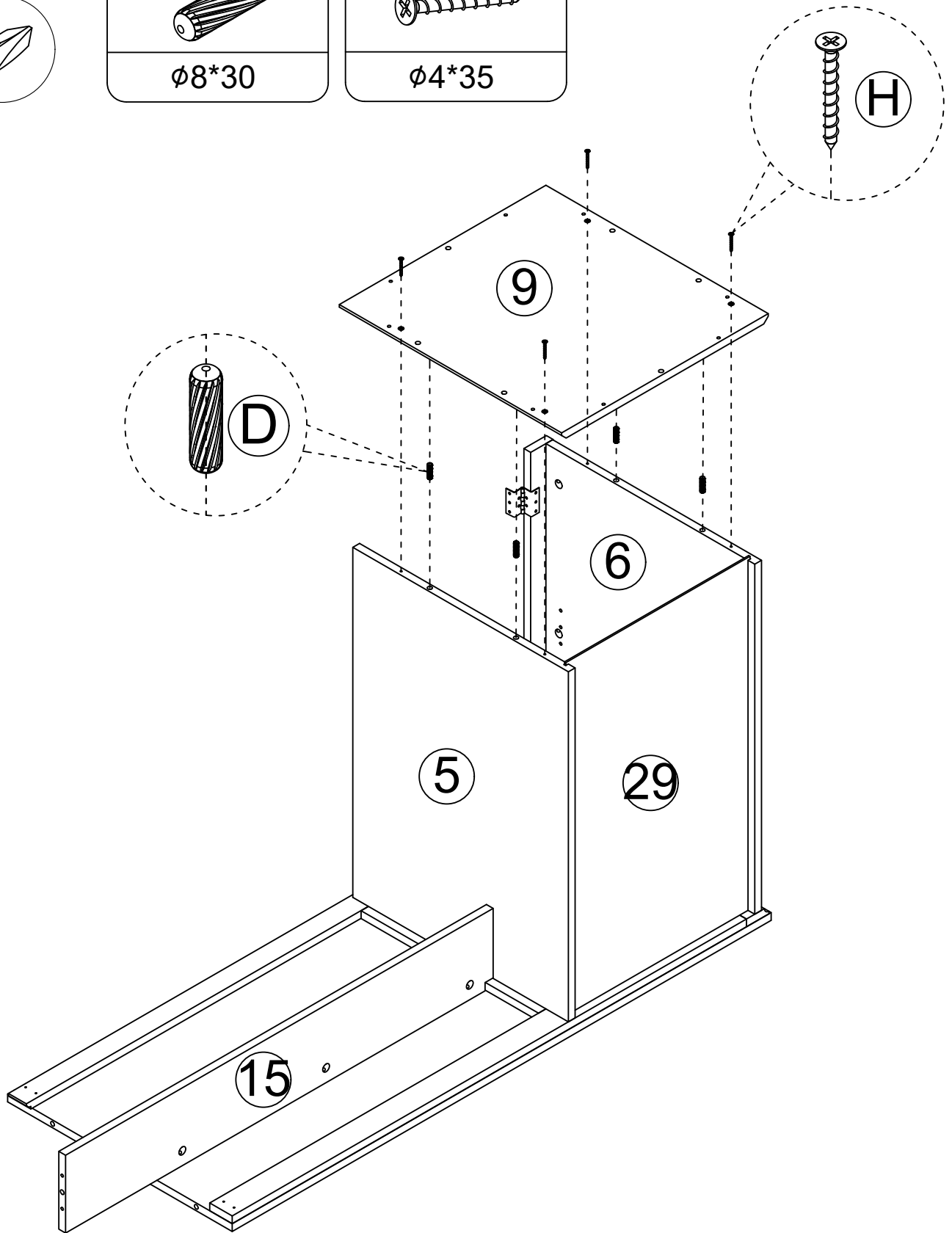

# STEP 23

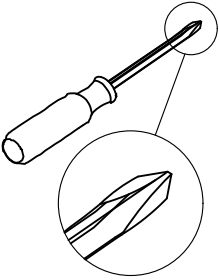

(B)	X8
A detailed illustration of a screw with a Phillips head and a threaded shaft.	
$\phi 6.5 \times 35$	

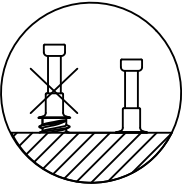
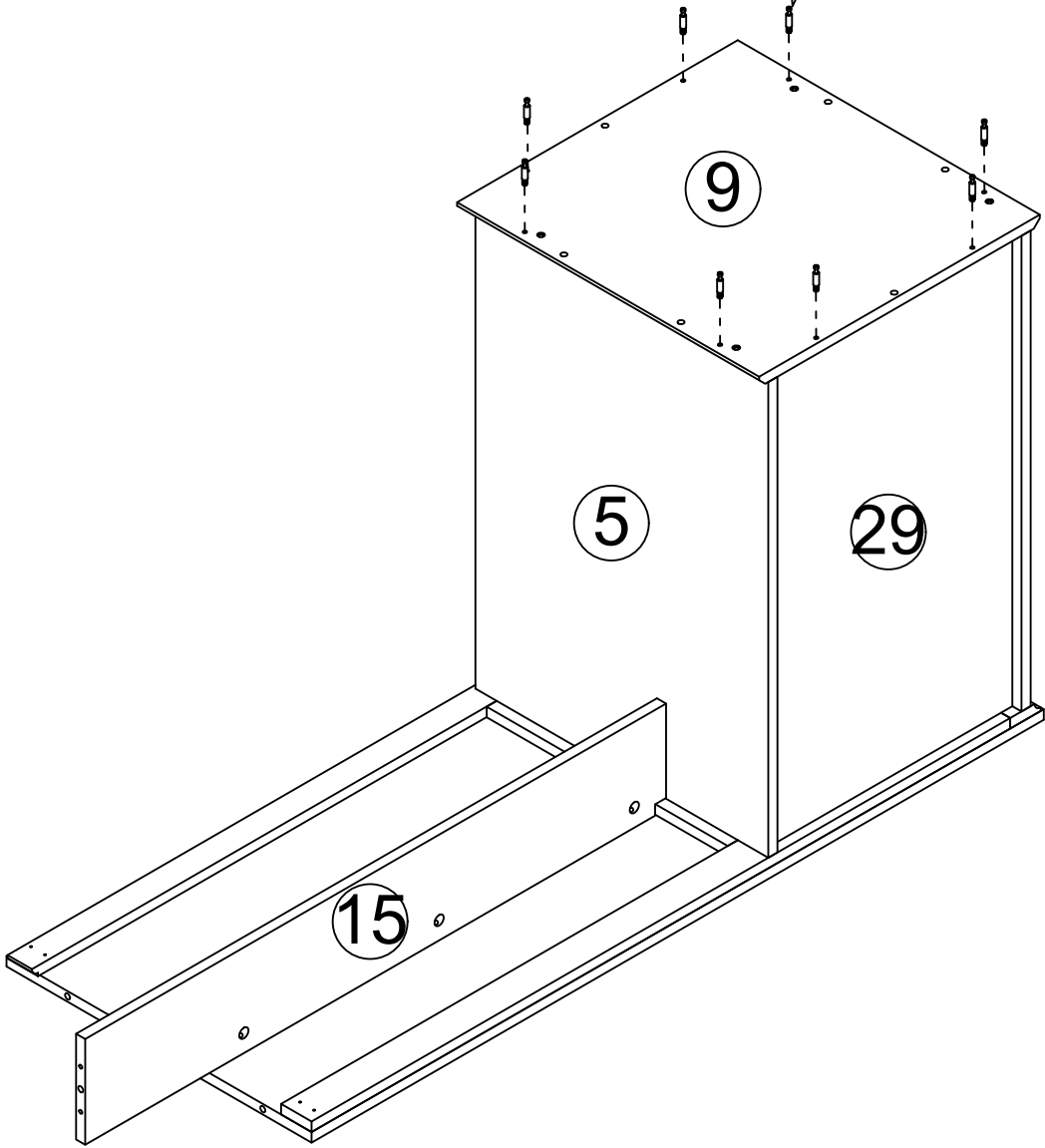
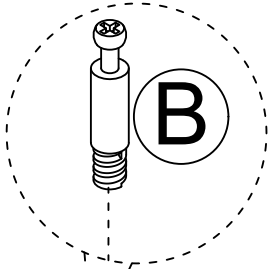

# STEP 24

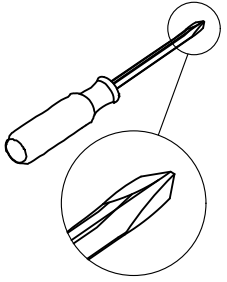

(A)	X8
	
ø15*9.5	

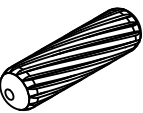
(D)	X6
	
ø8*30	

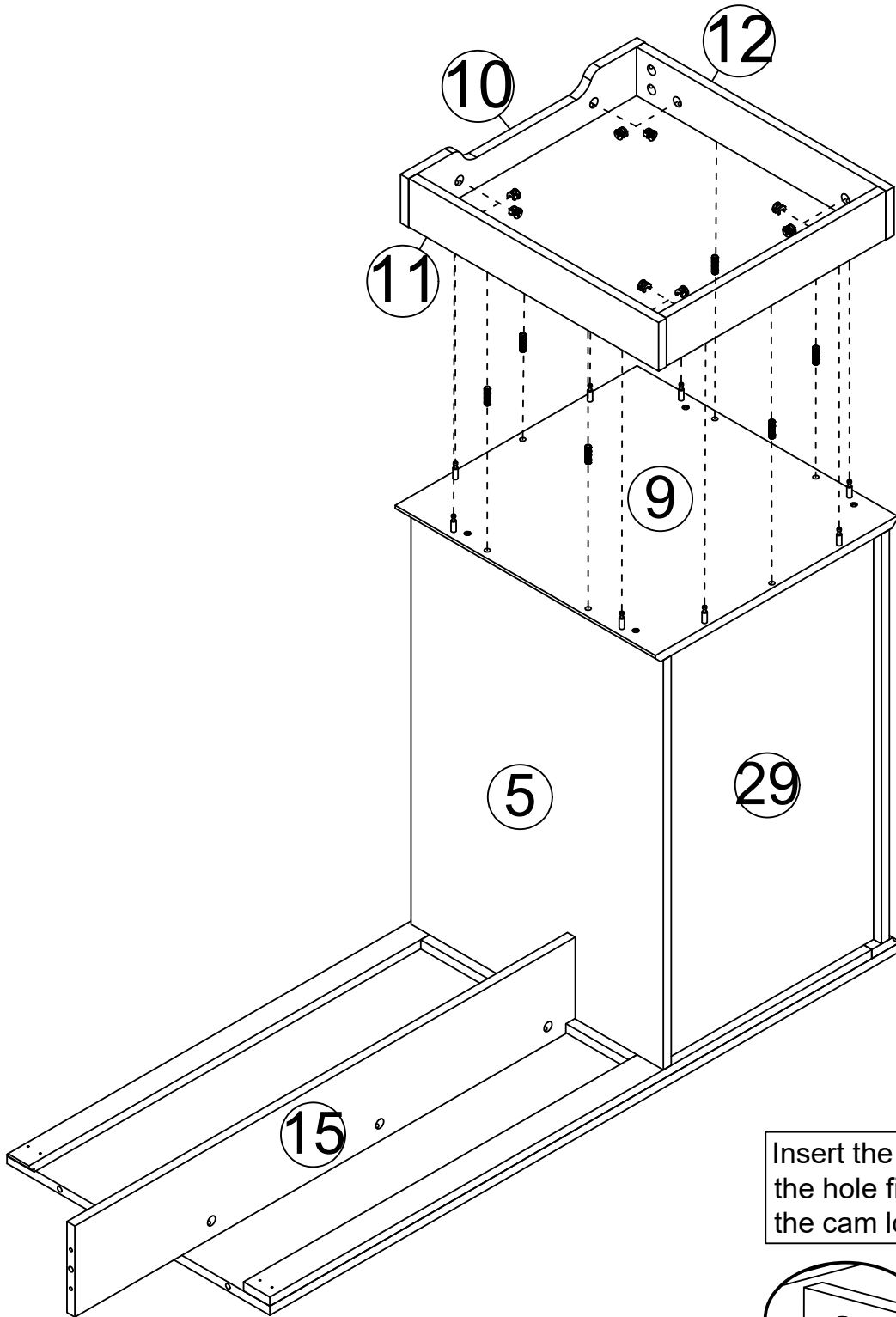

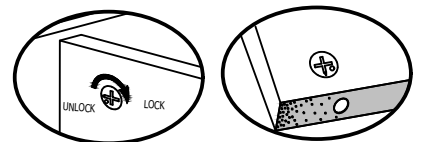

Insert the cam bolt into the hole first, then insert the cam lock and lock it.

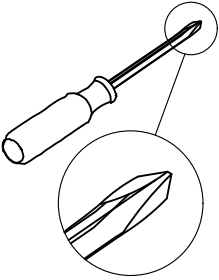

Proper orientation of CAM LOCK

# STEP 25



(F)	X2
	
ø3*12	

(N)	X2
	
M4*18	

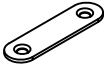
(R)	X1
	
45*12*1	

(L)	X1
	
130*14*21	

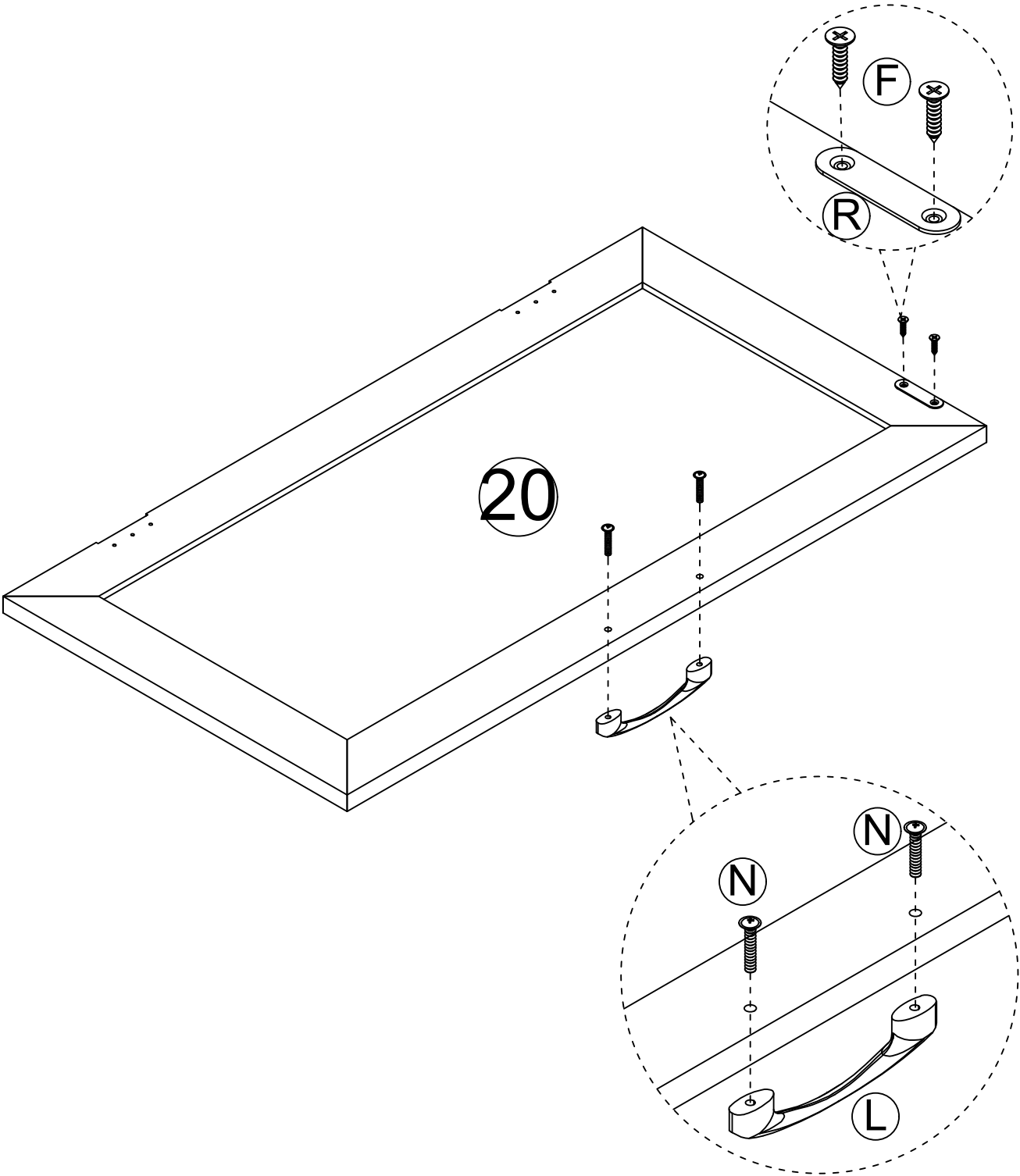

# STEP 26

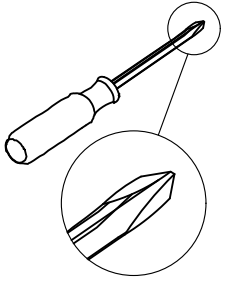

(F)	X6
	
ø3*12	

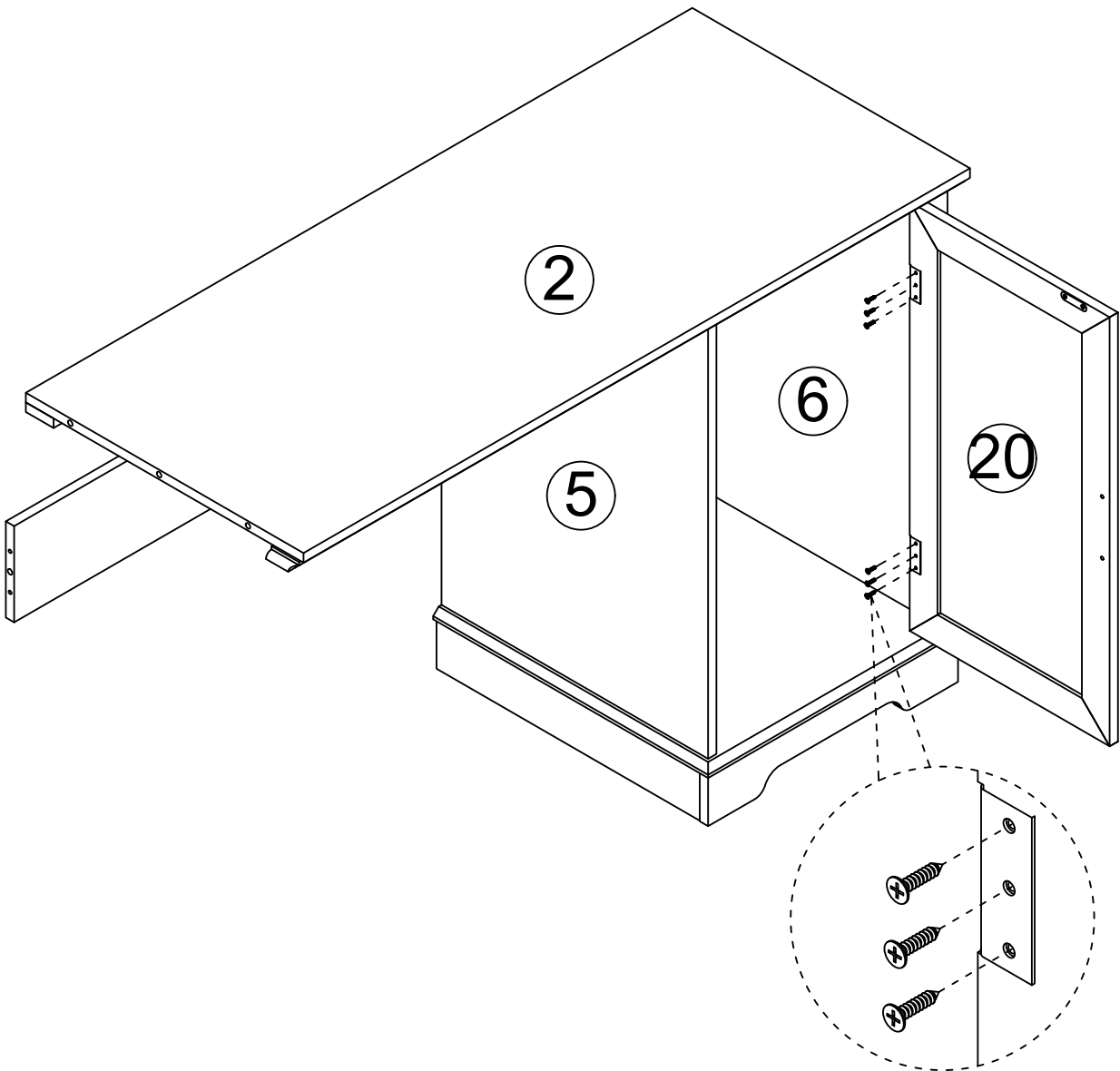

# STEP 27

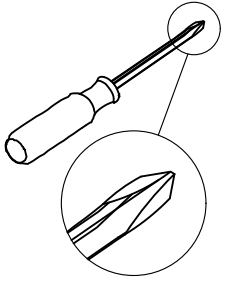

⊙	X4
	
φ5*16	

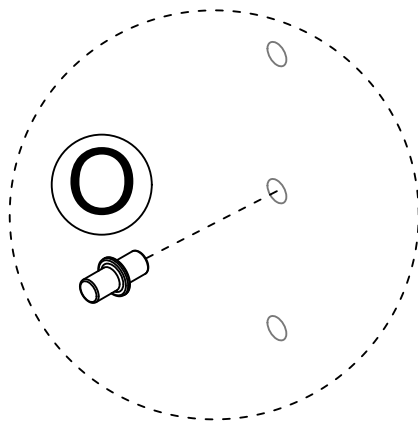
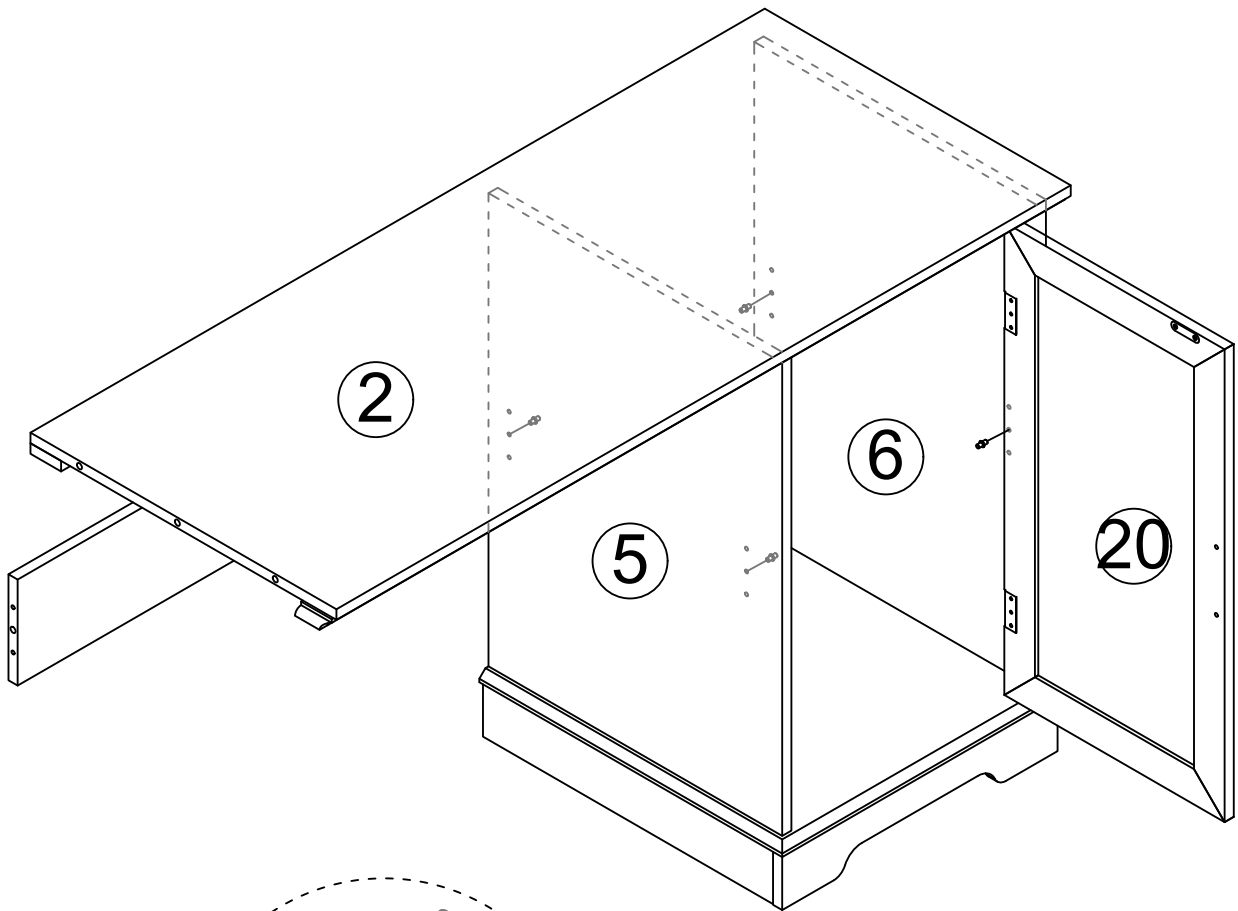

# STEP 28

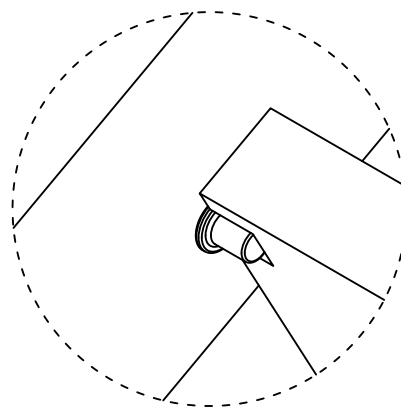
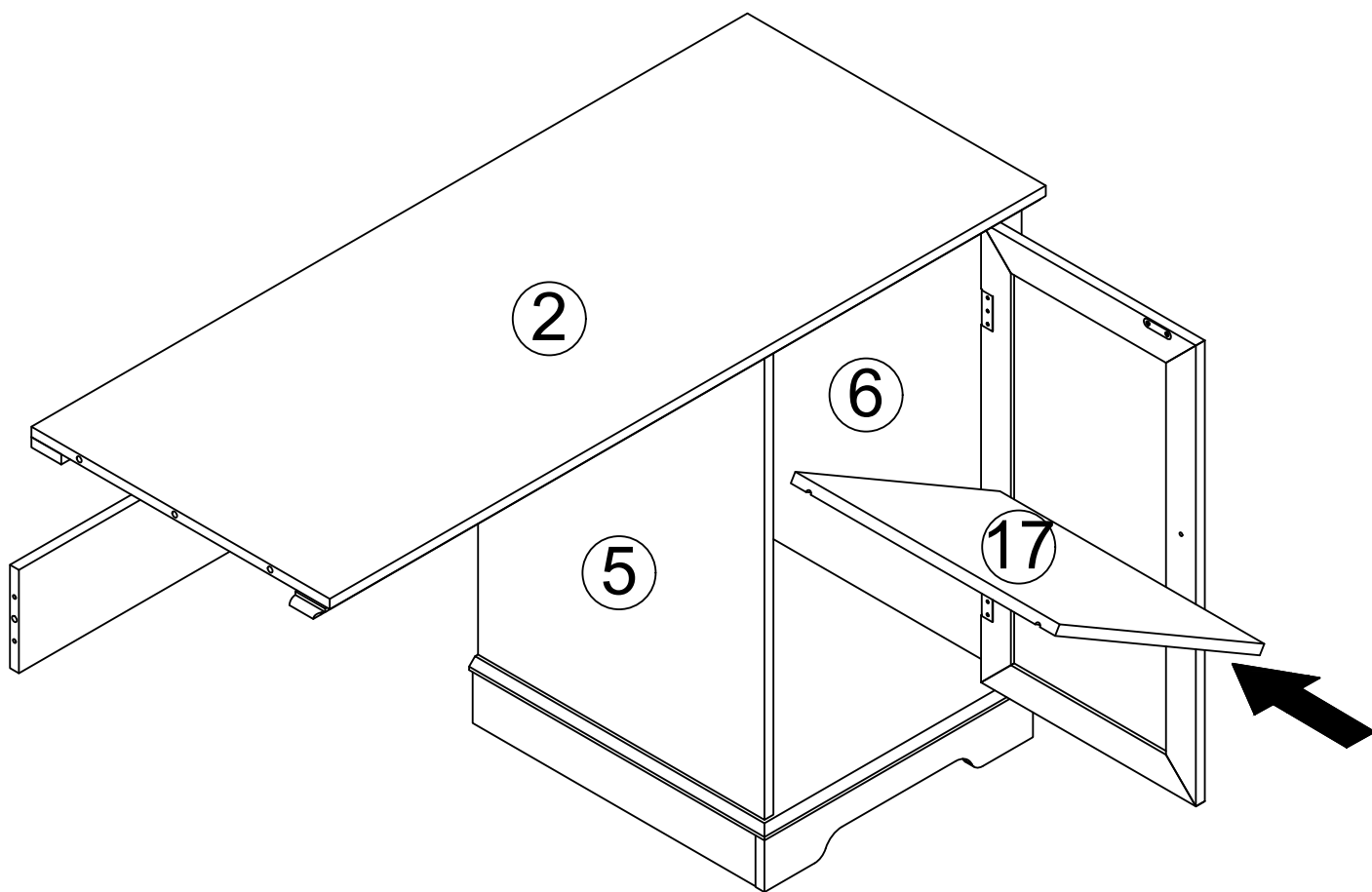
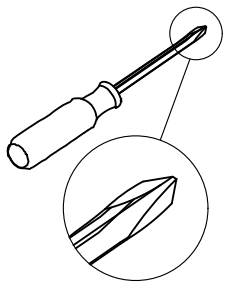

# STEP 29

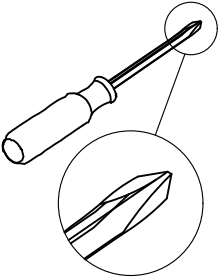

ⓓ	X4
ø8*30	

ⓙ	X2
ø6.3*40	

Ⓩ	X16
ø3×14mm	

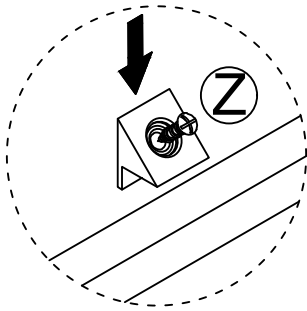
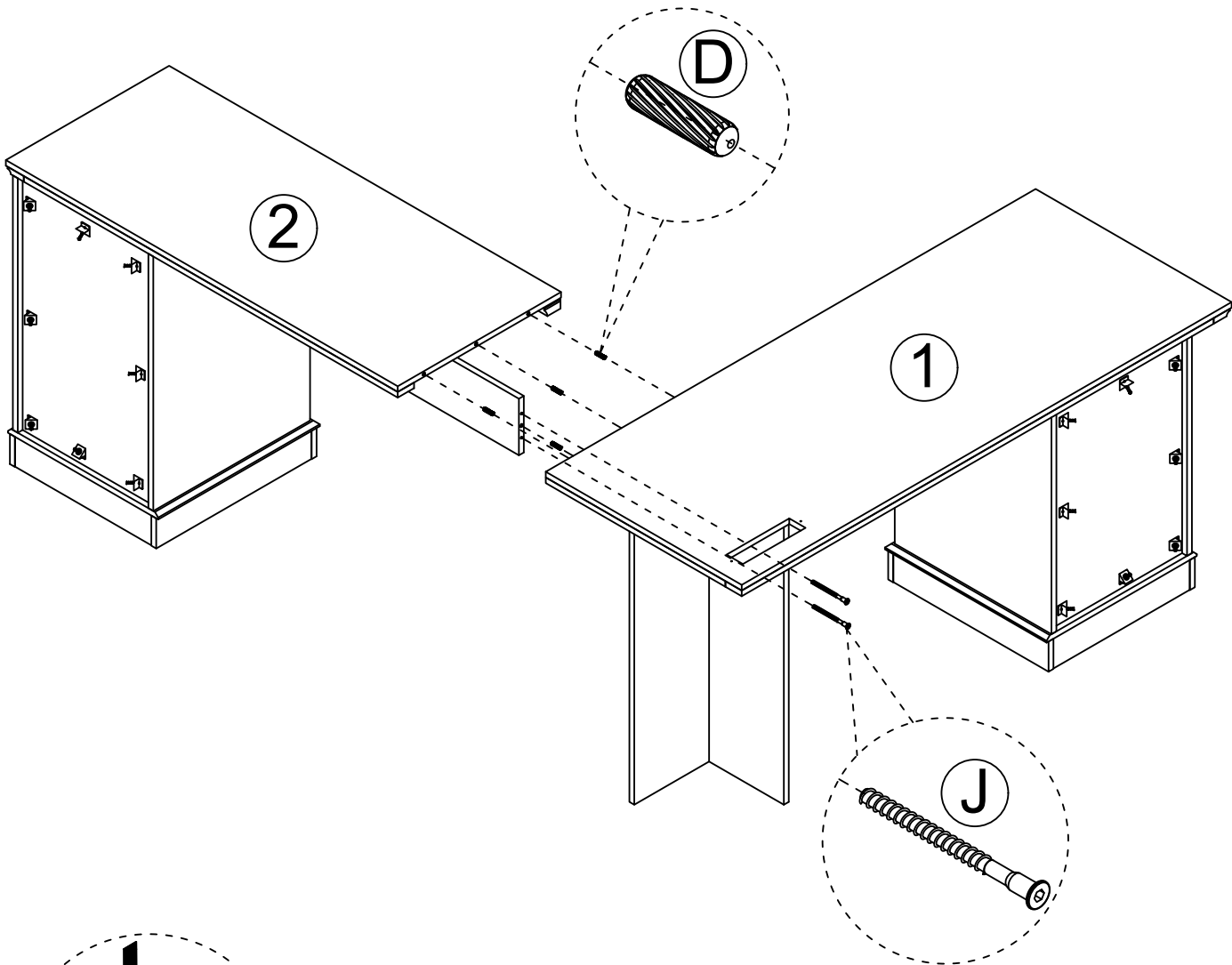

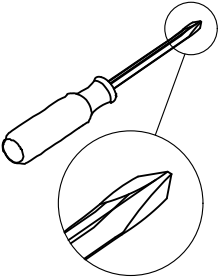

Insert the plastic buckle into the back plate slot, screw through the hole in the plastic buckle and lock it in place.

# STEP 30



Ⓛ	X8
	
ø4*14	

ⓕ	X2
	
ø3*12	

Ⓥ	X2
	
60*38*1.3	

Ⓦ	X1
	
230*53*45.5	

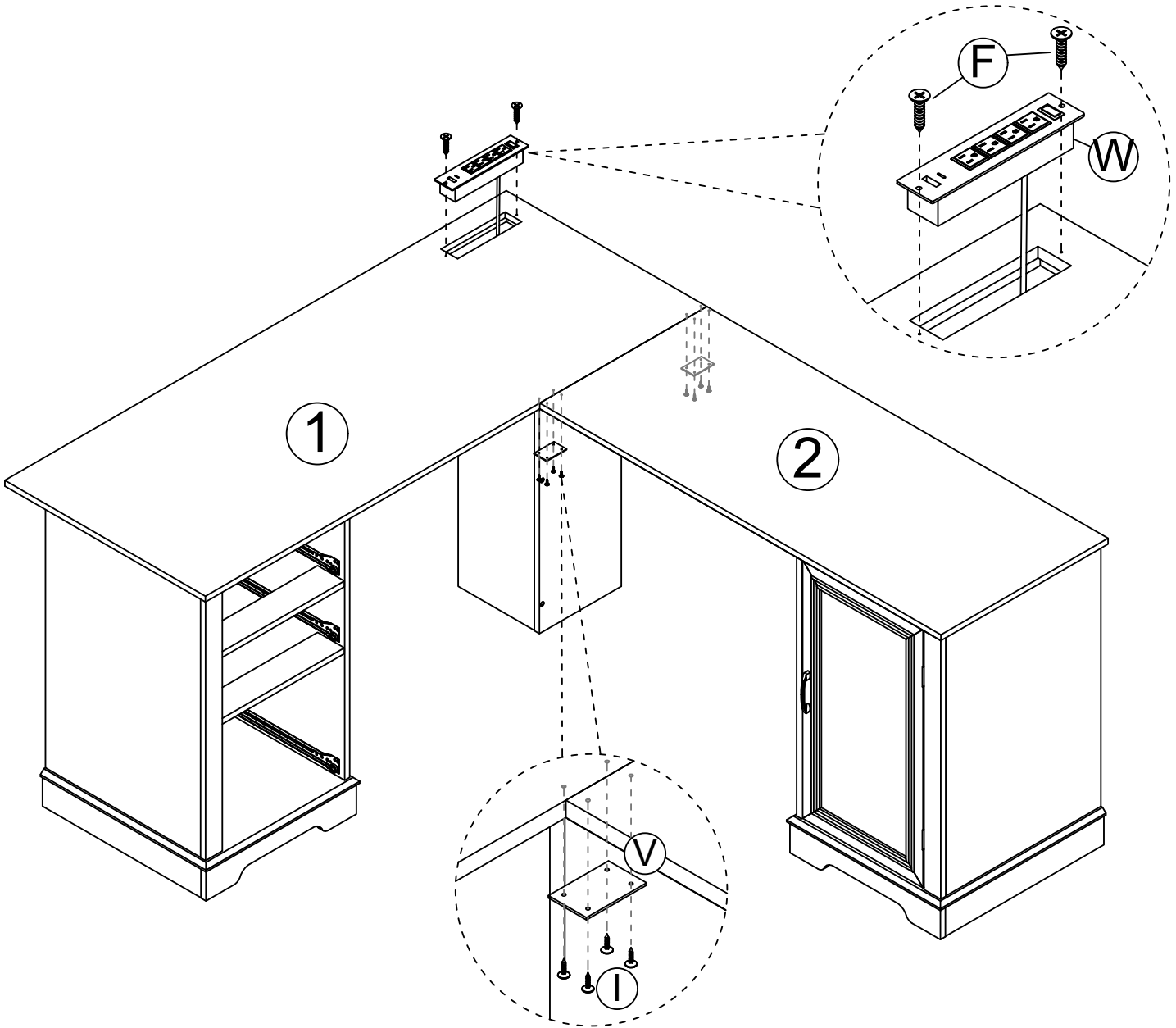

# STEP 31

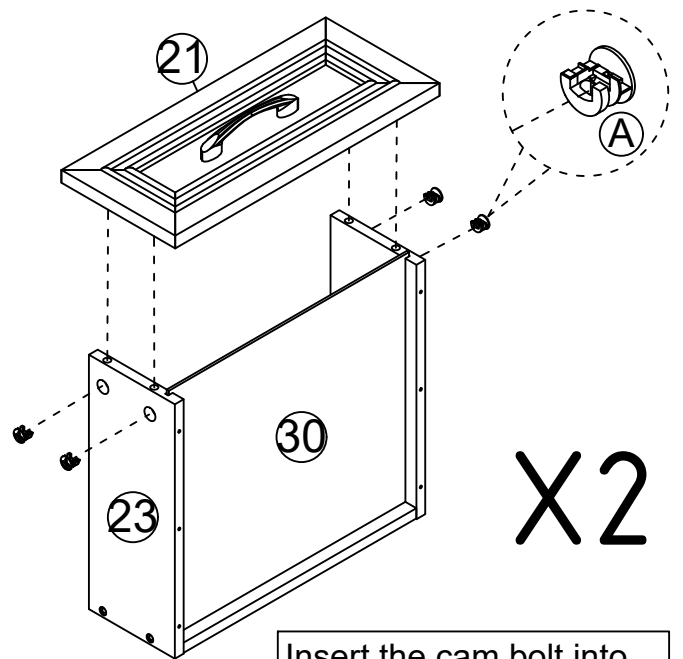
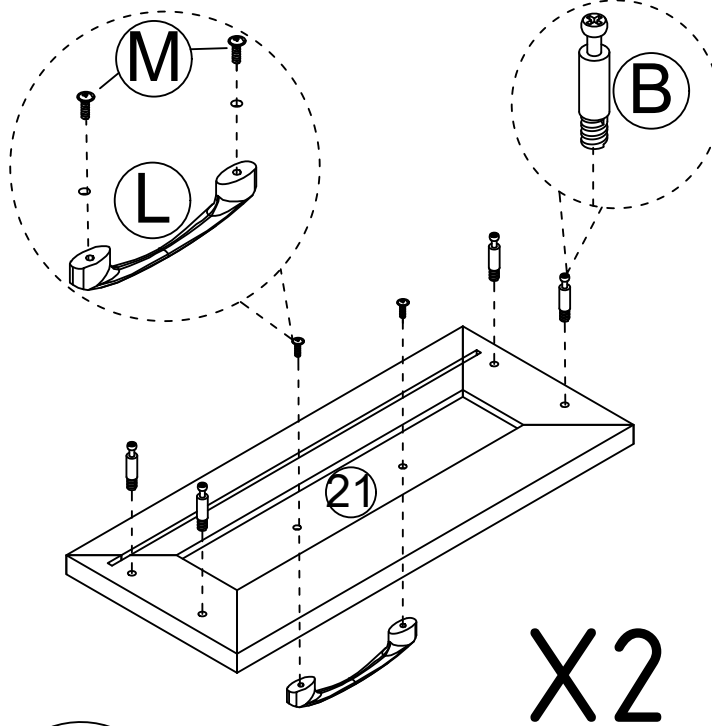
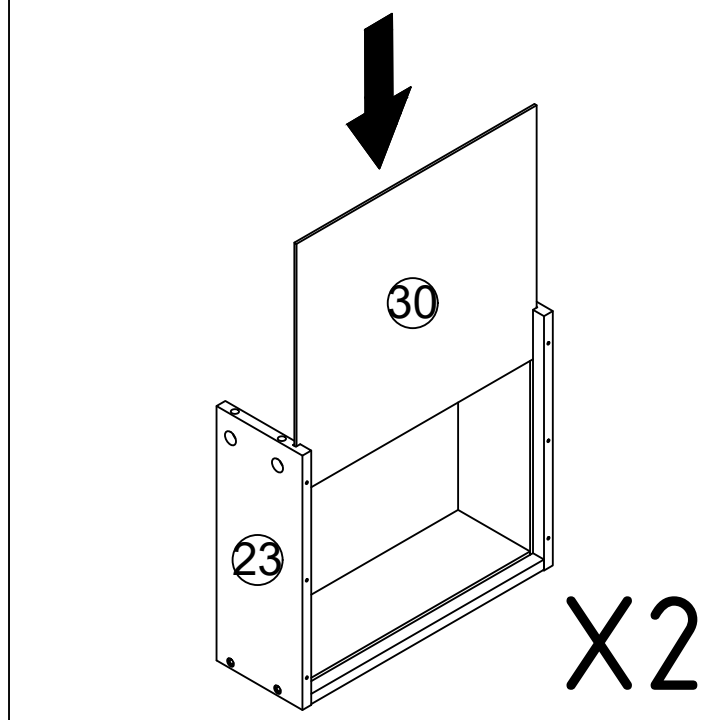
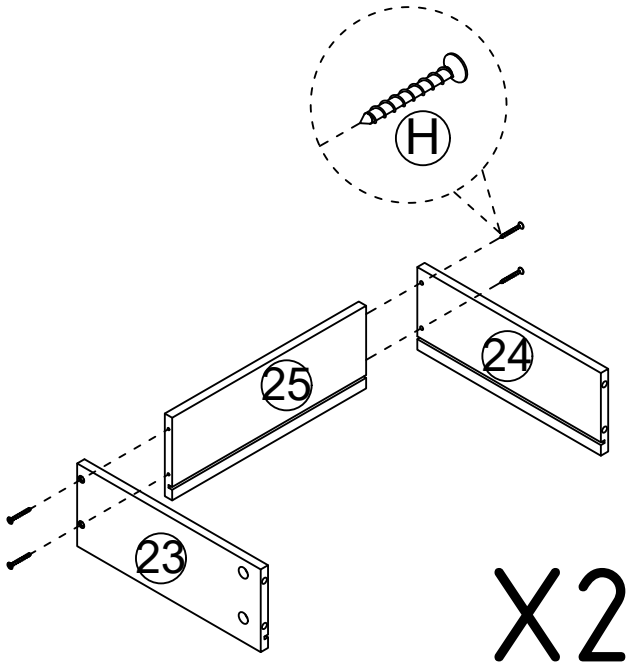
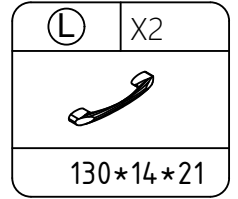
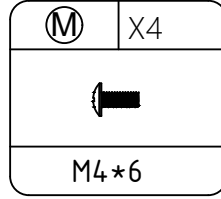
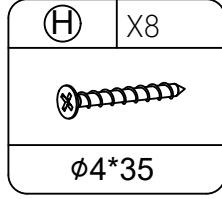
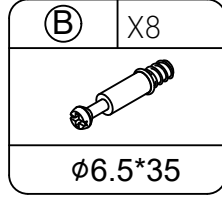
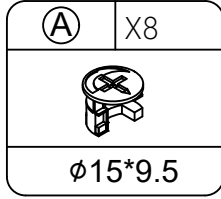
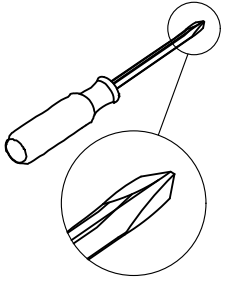

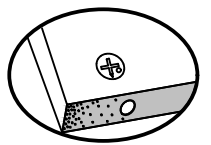
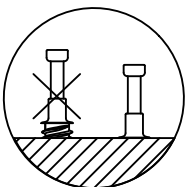

Insert the cam bolt into the hole first, then insert the cam lock and lock it.

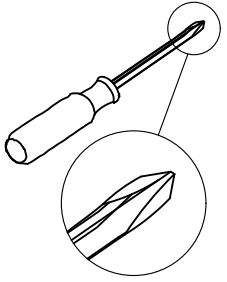

Proper orientation of CAM LOCK

# STEP 32

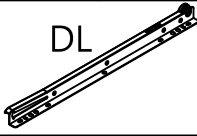

(G)	X12
	
ø3.5*14	

(P)-DL	X2
	
L=300	

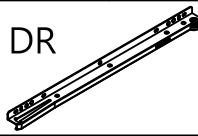
(P)-DR	X2
	
L=300	

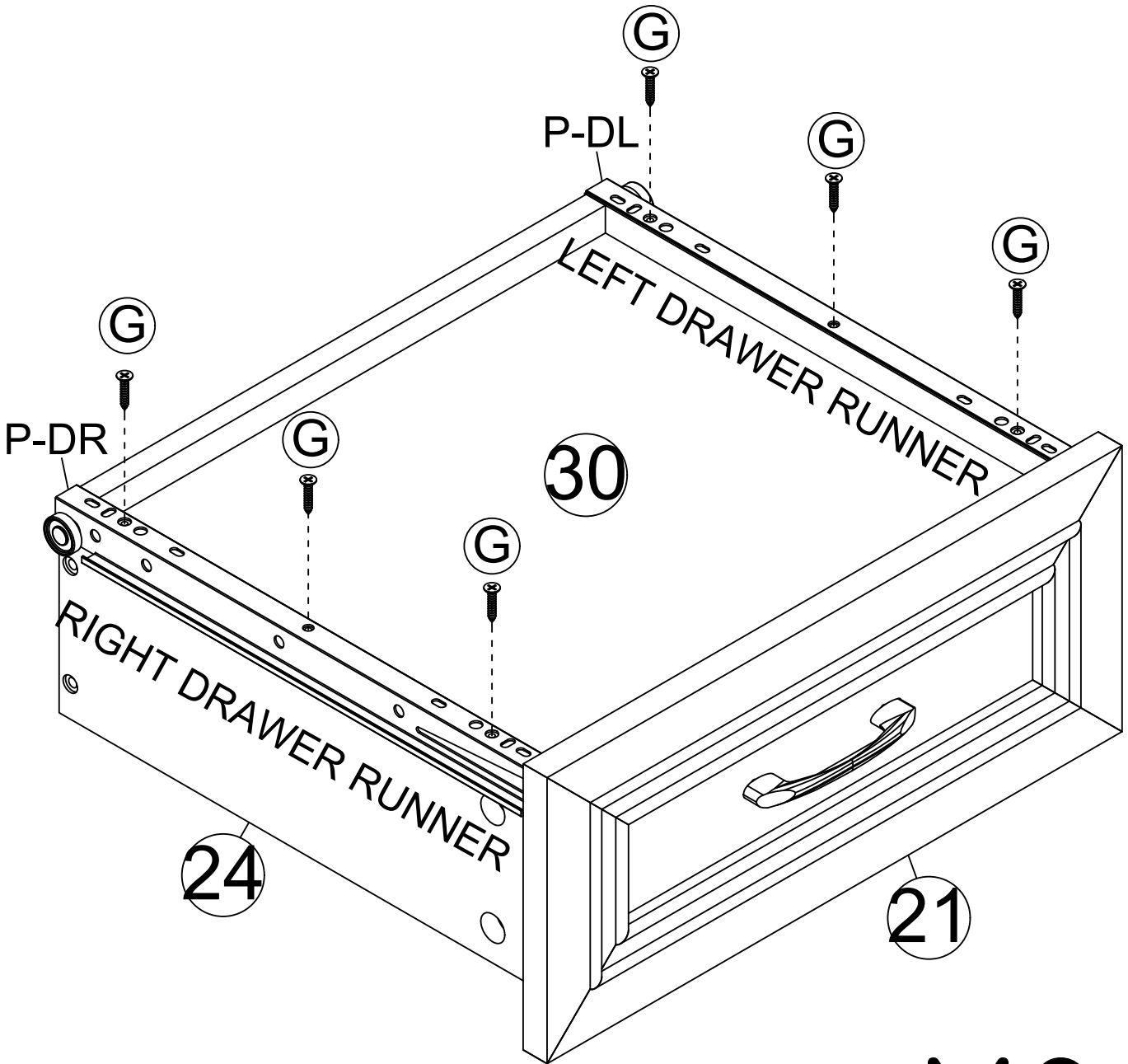

X2

# STEP 33

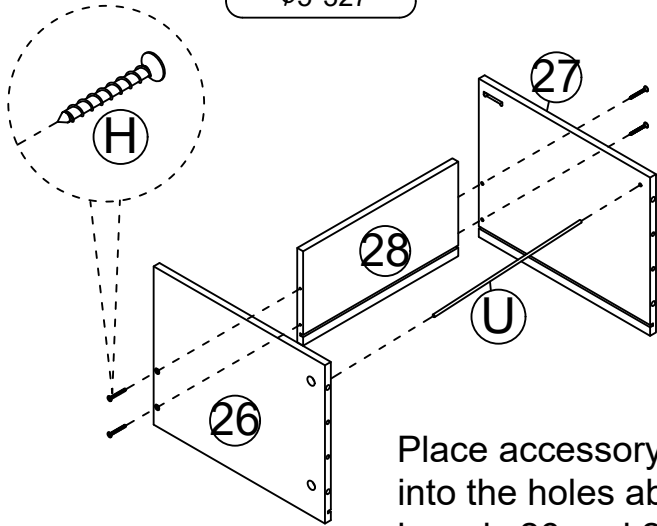
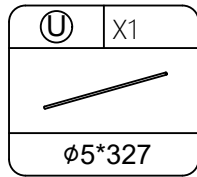
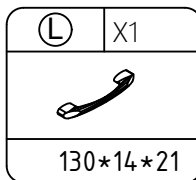
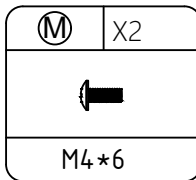
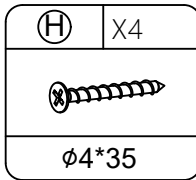
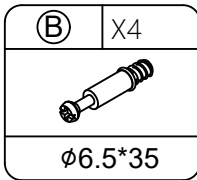
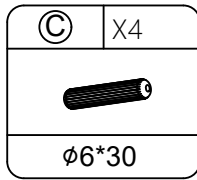
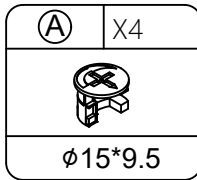
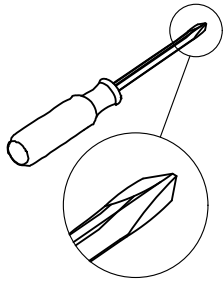

Place accessory U into the holes above boards 26 and 27.

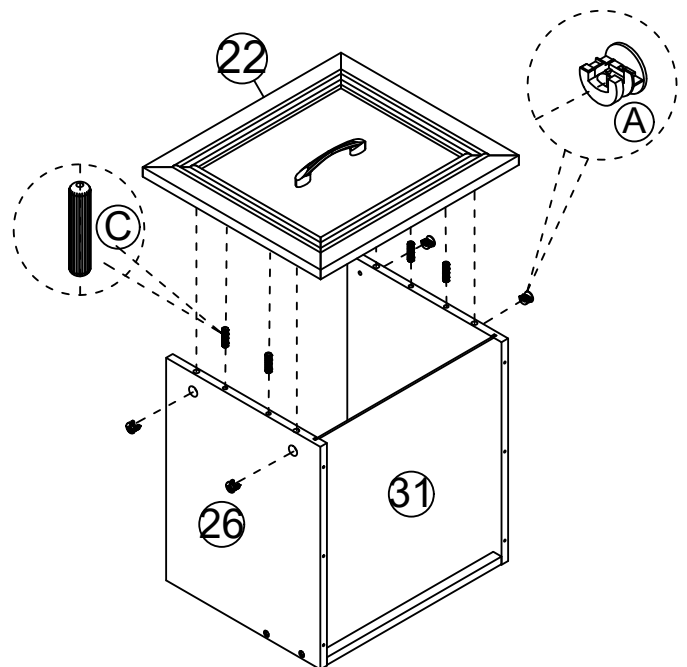
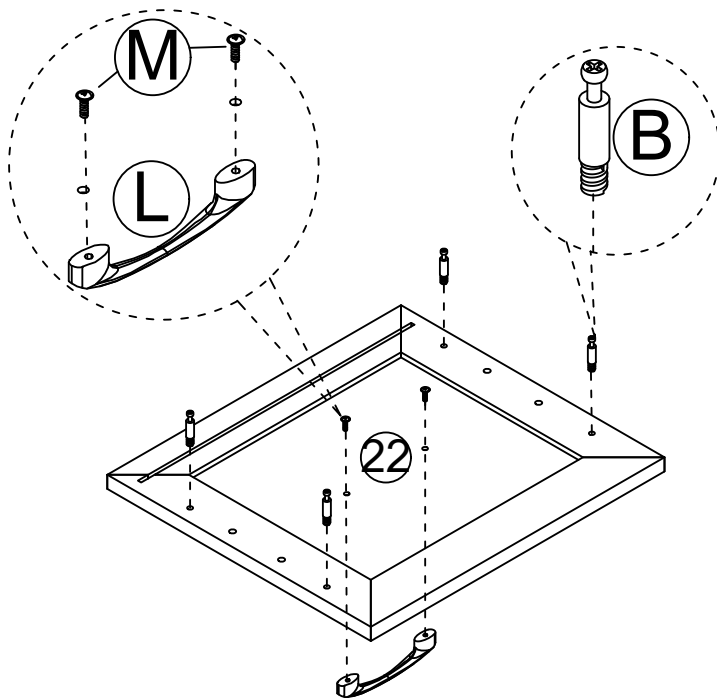
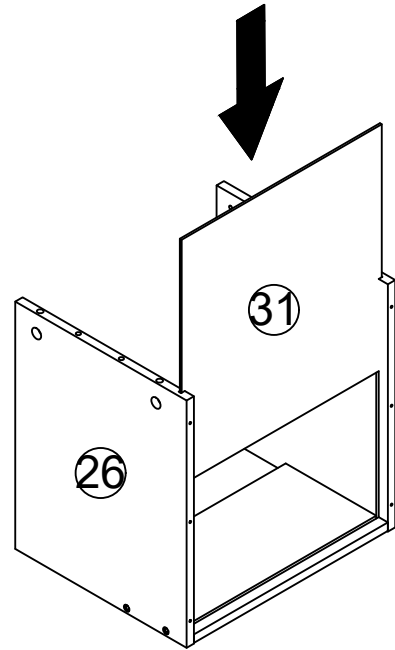

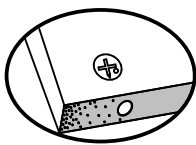
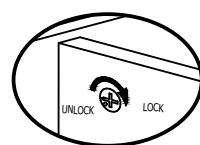
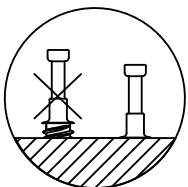

Insert the cam bolt into the hole first, then insert the cam lock and lock it.

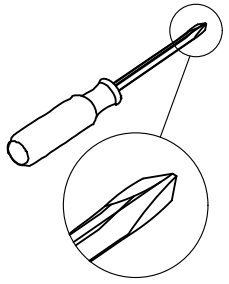

Proper orientation of CAM LOCK

# STEP 34

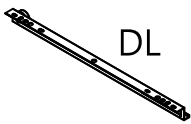

<b>G</b>	X6
	
$\phi 3.5 \times 14$	

<b>Q-DL</b>	X1
	DL
L=350	

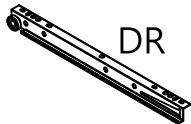
<b>Q-DR</b>	X1
	DR
L=350	

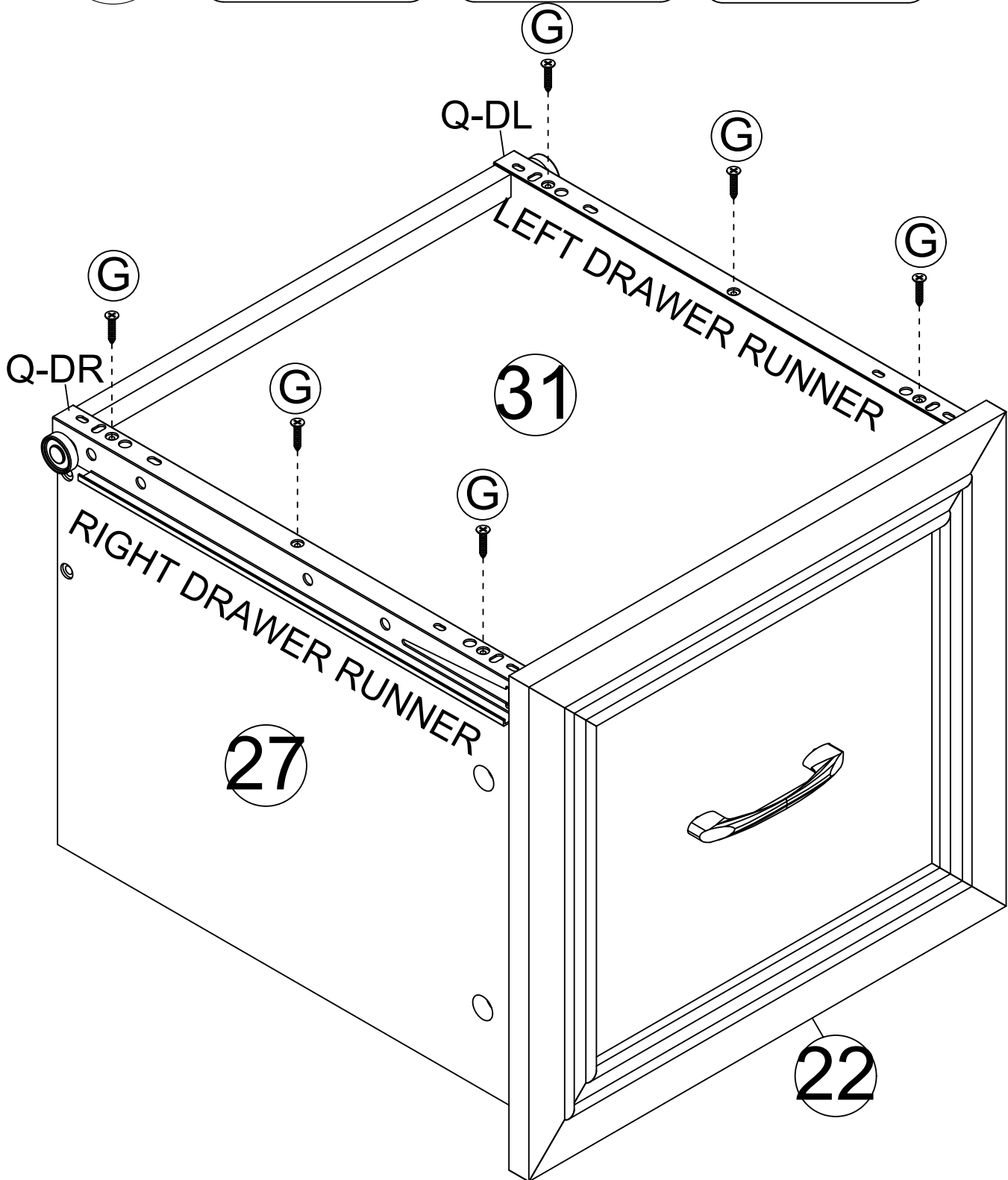

# STEP 35

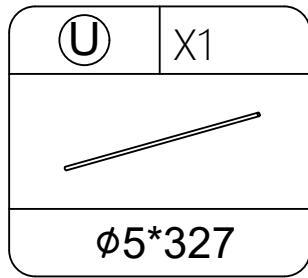
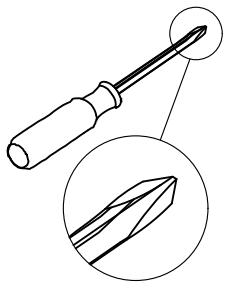

Place accessory U  
in the grooves of  
boards 26 and 27.

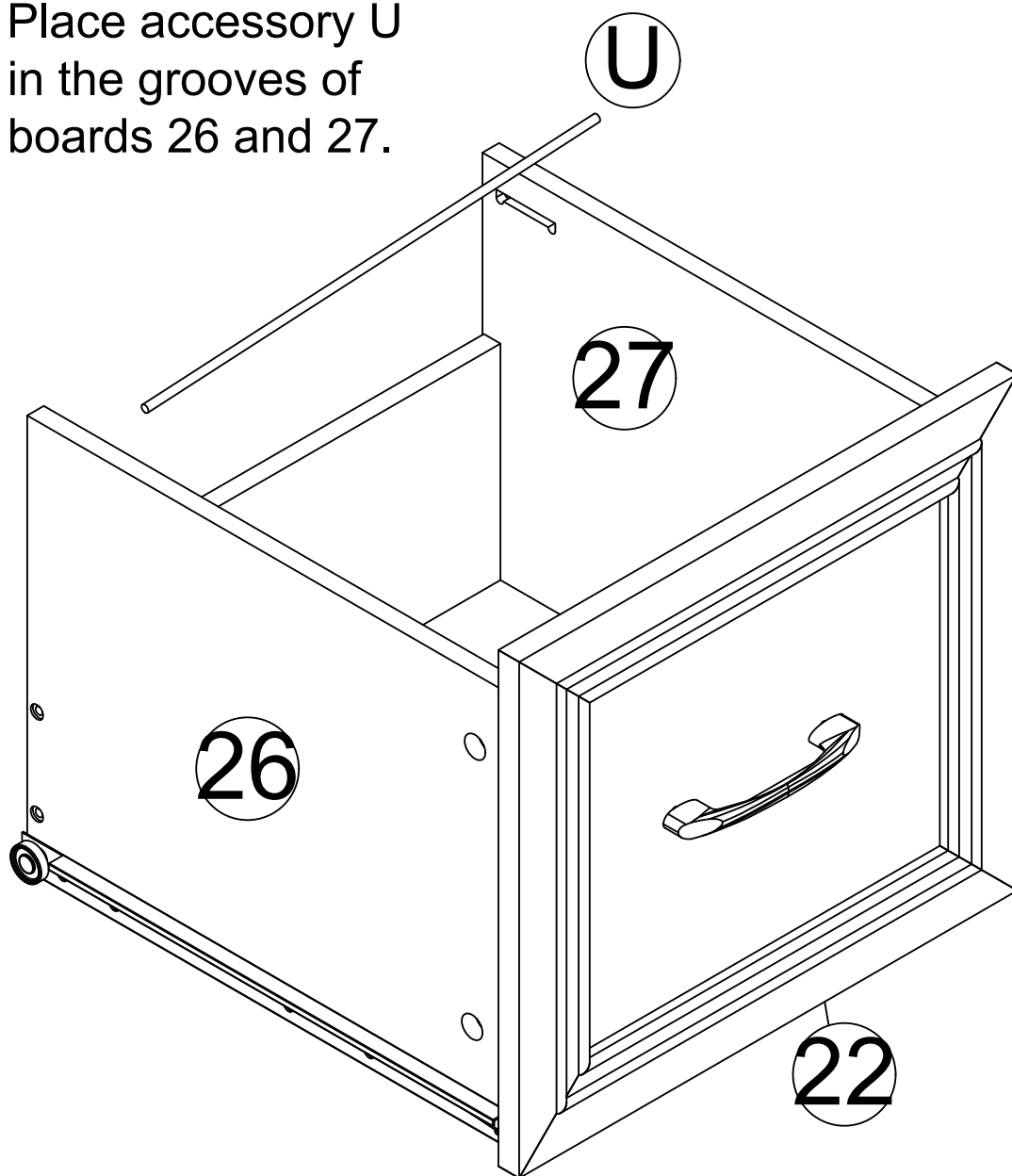

# STEP 36

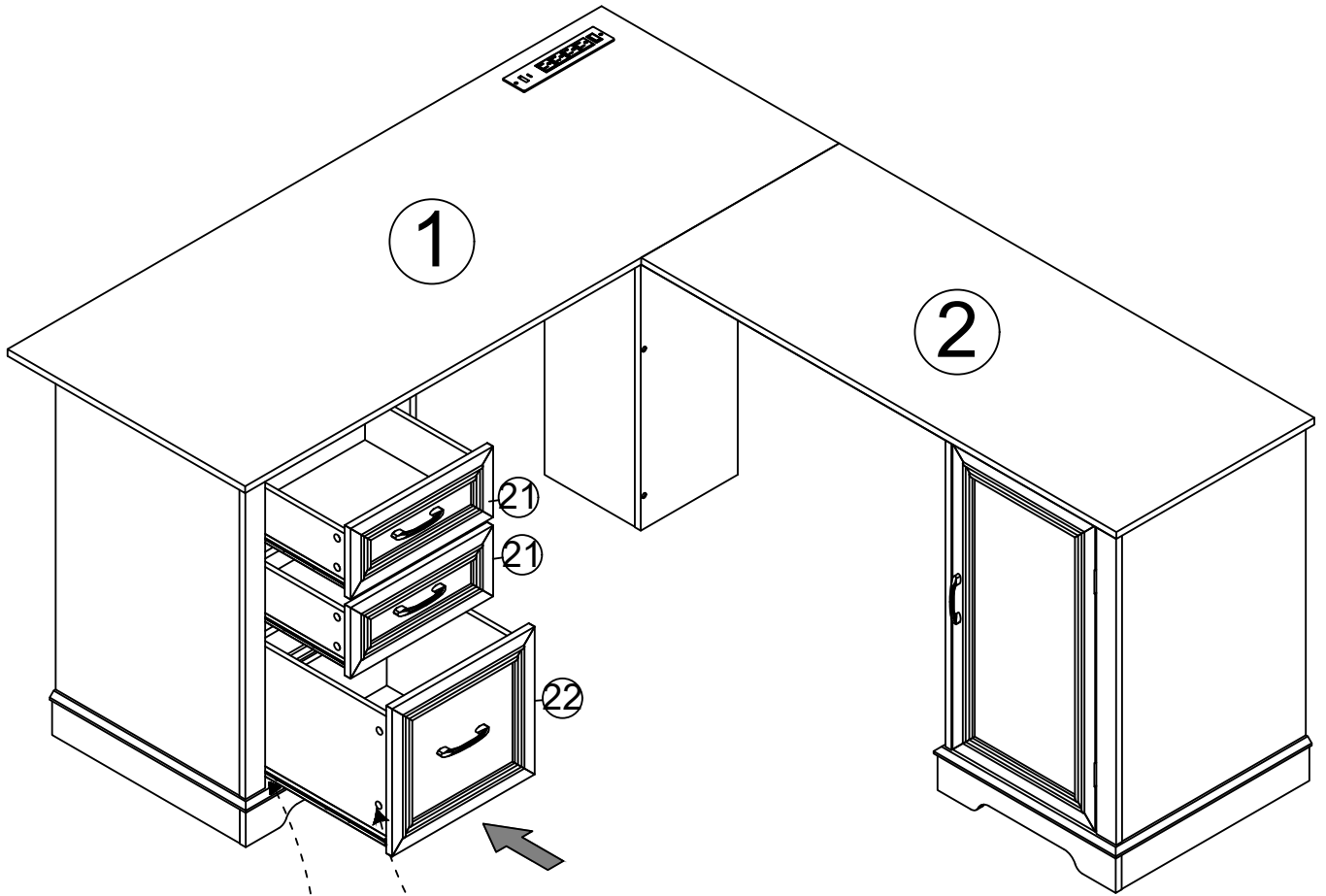
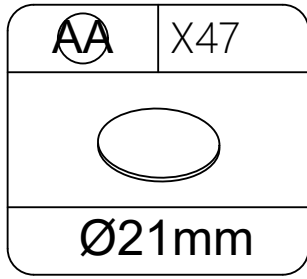
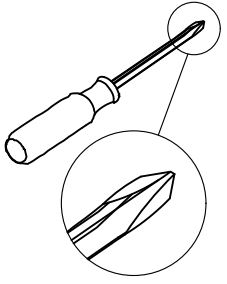

Cabinet Slide

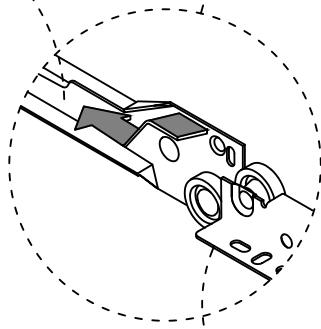

Drawer Slide

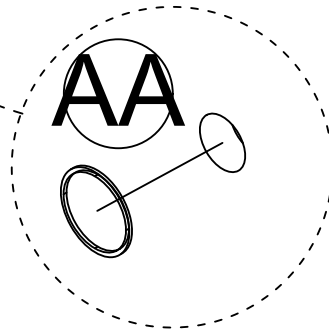

Using Cover-up Sticker (AA)\*47 to cover the exposed part of Screws.