

# Installation sanleitung

# Installation Instruction

# Instruction d'installation

SKU: N606P243179G/ N606P243181G/ N606P243182G

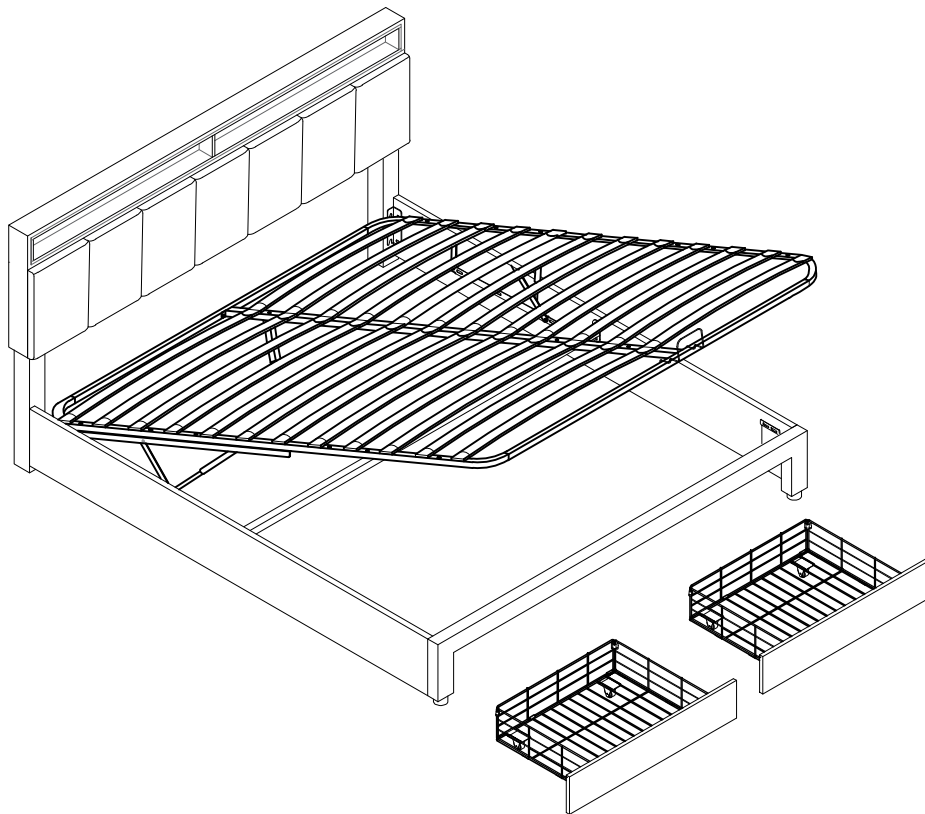

Unser Produkt wird Ihnen in 3 Paketen geliefert. Die Lieferzeiten dieser 3 Pakete können abweichen, bitte haben Sie etwas Geduld und vielen Dank für Ihr Verständnis.

Our product will be delivered to you in 3 packages. The delivery times of these 3 packages may differ, please be patient and thank you for your understanding.

Notre produit vous sera livré en 3 colis. Les délais de livraison de ces 3 colis peuvent différer, soyez patient et merci pour votre compréhension.

**UK**  
**CA**



## English

### IMPORTANT FOR GAS LIFT BEDS&MAINTAINCE

- Please place the mattress on top of the bed frame.
- Please do not pull on the strap handles.
- Please press heavily to release the compressed gas.
- Periodically check all screw & fixings to ensure they are secure.
- When moving your product, carefully lift into place.
- Wipe clean with a slightly damp cloth- please do not use abrasive chemicals or bleach.
- Do NOT allow children to operate the lift mechanism.
- Do NOT allow children near the lift base when operating the mechanism.
- Do NOT stand inside the bed or the internal storage base.
- Do NOT overload the internal storage base.
- DO NOT jump on the product or any of its parts.

## Deutsch

### WICHTIG FÜR GASLIFT-BETTEN&WARTUNG

- Bitte legen Sie die Matratze oben auf den Bettrahmen.
- Bitte ziehen Sie nicht an den Gurtgriffen.
- Bitte drücken Sie kräftig, um das komprimierte Gas freizusetzen.
- Überprüfen Sie regelmäßig alle Schrauben und Befestigungen, um sicherzustellen, dass sie sicher sind.
- Wenn Sie Ihr Produkt bewegen, heben Sie es vorsichtig an seinen Platz.
- Mit einem leicht feuchten Tuch abwischen - bitte keine scheuernden Chemikalien oder Bleichmittel verwenden.
- Erlauben Sie Kindern NICHT, den Hebemechanismus zu bedienen.
- Lassen Sie Kinder NICHT in die Nähe des Liftsockels, wenn Sie den Mechanismus bedienen.
- Stellen Sie sich NICHT in das Bett oder in die Innenablage.
- Überlasten Sie den internen Liftsockel NICHT.
- Springen Sie NICHT auf das Produkt oder eines seiner Teile.

## Français

### IMPORTANT POUR LES LITS À RELEVAGE DE GAZ&MAINTENANCE

- Veuillez placer le matelas sur le dessus du cadre de lit.
- Ne tirez pas sur les poignées de la sangle.
- Appuyez fortement pour libérer le gaz comprimé.
- Vérifiez régulièrement que toutes les vis et fixations sont bien en place.
- Lorsque vous déplacez votre produit, soulevez-le avec précaution pour le mettre en place.
- Nettoyez avec un chiffon légèrement humide - n'utilisez pas de produits chimiques abrasifs ou d'eau de Javel.
- Ne laissez pas les enfants utiliser le mécanisme de levage.
- Ne laissez pas les enfants s'approcher de la base de levage lorsqu'ils actionnent le mécanisme.
- Ne vous tenez PAS à l'intérieur du lit ou de la base de stockage interne.
- Ne surchargez pas la base de stockage interne.
- Ne pas sauter sur le produit ou l'une de ses parties.

## Italiano

### IMPORTANTE PER I LETTI CON SOLLEVAMENTO A GAS E LA MANUTENZIONE

- Posizionare il materasso sopra la struttura del letto.
- Non tirare le maniglie della cinghia.
- Premere con forza per rilasciare il gas compresso.
- Controllare periodicamente tutte le viti e i fissaggi per assicurarsi che siano saldi.
- Quando si sposta il prodotto, sollevarlo con cautela.
- Pulire con un panno leggermente umido, senza usare prodotti chimici abrasivi o candeggina.
- NON permettere ai bambini di azionare il meccanismo di sollevamento.
- NON permettere ai bambini di avvicinarsi alla base di sollevamento quando si aziona il meccanismo.
- NON sostare all'interno del letto o della base di contenimento interna.
- NON sovraccaricare la base di contenimento interna.
- NON saltare sul prodotto o sulle sue parti.

## Español

### IMPORTANTE PARA LAS CAMAS ELEVADORAS DE GAS & MANTENIMIENTO

- Coloque el colchón sobre el somier.
- No tire de las asas de la correa.
- Presione con fuerza para liberar el gas comprimido.
- Compruebe periódicamente que todos los tornillos y fijaciones estén bien sujetos.
- Al mover el producto, levántelo con cuidado para colocarlo en su sitio.
- Limpie con un paño ligeramente humedecido; no utilice productos químicos abrasivos ni lejía.
- NO permita que los niños accionen el mecanismo de elevación.
- NO permita que los niños se acerquen a la base elevadora cuando accionen el mecanismo.
- NO se ponga de pie dentro de la cama o de la base de almacenamiento interna.
- NO sobrecargue el somier.
- NO salte sobre el producto ni sobre ninguna de sus piezas.

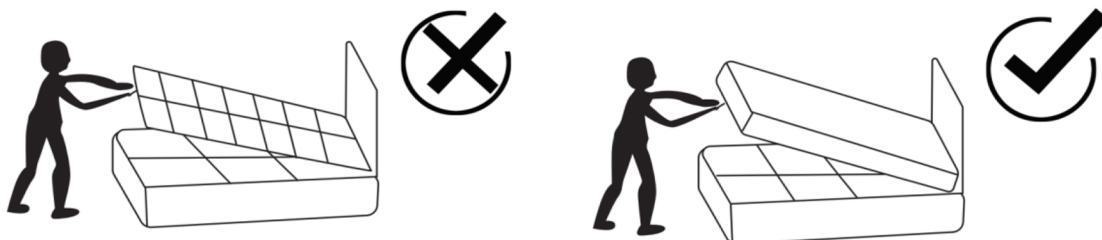

# Detail View

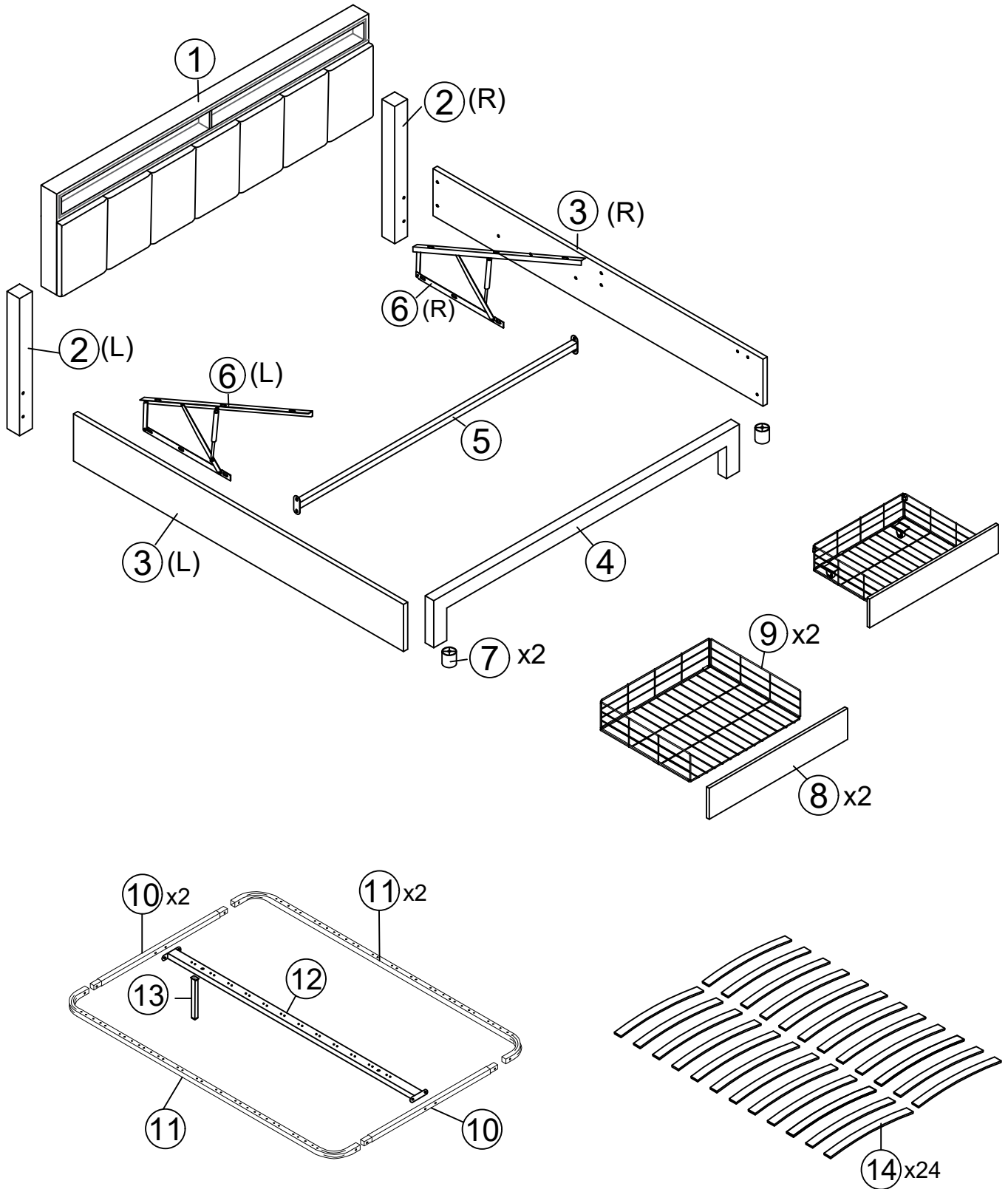





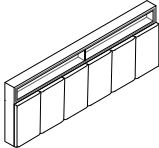
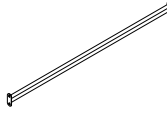

# Part List

## N606P243179G

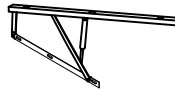
<p>① x1</p>  <p>Head board</p>	<p>⑤ x1</p>  <p>Cross bar</p>
---	--

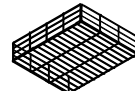
## N606P243182G





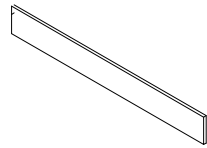
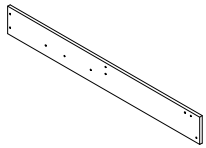
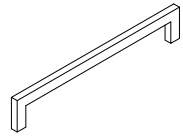
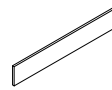
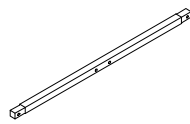
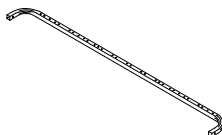
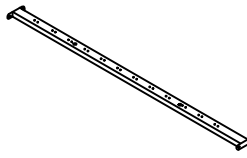
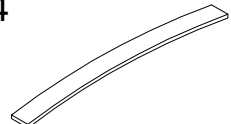









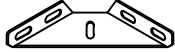
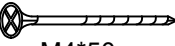

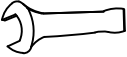

<p>②L x1</p>  <p>Head board leg</p>	<p>②R x1</p>  <p>Head board leg</p>	<p>⑥L x1</p>  <p>Gas lift</p>
<p>⑥R x1</p>  <p>Gas lift</p>	<p>⑦ x2</p>  <p>Bed legs</p>	<p>⑨ x2</p>  <p>Drawer</p>
<p>⑬ x1</p>  <p>Middle support leg</p>		

## N606P243181G

<p>③L x1</p>  <p>Side rail</p>	<p>③R x1</p>  <p>Side rail</p>	<p>④ x1</p>  <p>Foot board</p>
<p>⑧ x2</p>  <p>Drawer outer board</p>	<p>⑩ x2</p>  <p>Metal frame cross bar</p>	<p>⑪ x2</p>  <p>Metal frame side bar</p>
<p>⑫ x1</p>  <p>Metal frame middle bar</p>	<p>⑭ x24</p>  <p>Slat</p>	

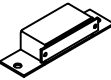
# Hardware list

## N606P243182G

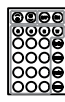
<p>A x1</p>  <p>Allen Key</p>	<p>B x19</p>  <p>M8x45mm</p> <p>Bolts</p>	<p>C x2</p>  <p>Hinge</p>
<p>D x38</p>  <p>M8x18mm</p> <p>Bolts</p>	<p>E x2</p>  <p>Little "7" Connector</p>	<p>F x2</p>  <p>Metal Corner</p>
<p>G x2</p>  <p>M4*50mm</p> <p>Nails</p>	<p>H x1</p>  <p>"7" Connector</p>	<p>I x4</p>  <p>Nuts</p>
<p>J x1</p>  <p>Spanner</p>	<p>K x14</p>  <p>M8</p> <p>Nuts</p>	<p>L x12</p>  <p>Middle slats cap</p>
<p>M x24</p>  <p>End slats cap</p>	<p>N x1</p>  <p>Stopper</p>	<p>O x8</p>  <p>Wheel</p>
<p>P x6</p>  <p>Drawer fittings</p>	<p>Q x4</p>  <p>Drawer fittings</p>	<p>R x3</p>  <p>Roller latch</p>
<p>S x12</p>  <p>M3*16mm</p> <p>Nails</p>	<p>T x1</p>  <p>Power adapter</p>	<p>U x1</p>  <p>Color controller</p>
<p>V x1</p>  <p>Remote control</p>		

**DE:** Vor dem Einbau die Schrauben in die Löcher stecken und festziehen, aber nicht bis 100%, 70% bis 80% anziehen reicht aus. Schließlich, nachdem alle Schrauben installiert sind, ziehen Sie alle Schrauben auf 100%.

Wenn Sie auf diese Probleme stoßen, wie z. B. Fehlausrichtung der Löcher oder Unfähigkeit, bestimmte Teile zu installieren, überprüfen Sie bitte, ob die Schrauben korrekt verwendet werden und passen Sie die Dichtigkeit der Schrauben an.

**UK:** Before installation, insert the screws into the holes and tighten them, but do not tighten them to 100%, 70% to 80% is sufficient. Finally, after all screws are installed, tighten all screws to 100%.

If you encounter these issues, such as if the holes cannot be aligned or some parts cannot be installed, please check if the screws are used correctly and adjust the tightness of the screws.

**FR:** Insérer la vis dans le trou avant la fin de l'assemblage, serrer la vis, mais ne pas serrer à 100%, 70% ~ 80% est correct. Enfin, une fois que toutes les vis sont bien serrées, toutes les vis sont serrées à 100%.

Si vous rencontrez ces problèmes, par exemple si les trous ne sont pas alignés ou si certaines pièces ne peuvent pas être montées, vérifiez que les vis sont utilisées correctement et Ajustez leur serrage.

Attention: Do not tighten the screws before completing the entire installation. If you have any difficulty with the installation process, please feel free to contact us.

### Step 1

Fix the Headboard legs ② to the Headboard ① with Bolts B by using Allen key A. You can chose the holes a and c , b and d or c and e. For easy installation, please open the headboard cover first.

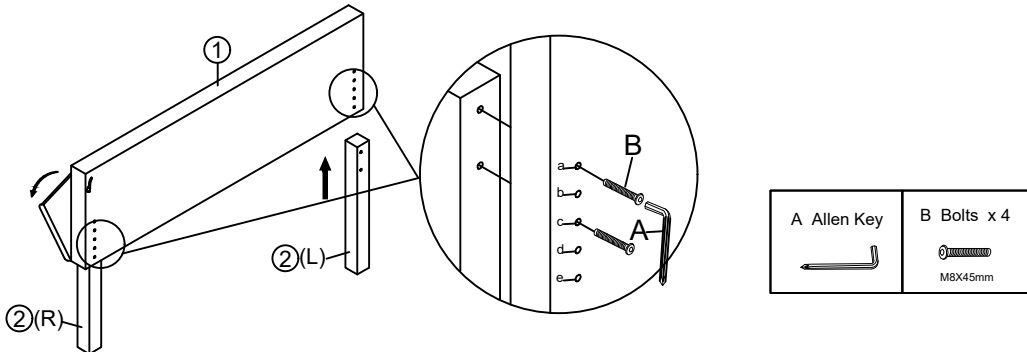

### Step 2

At first separate R into R1 and R2, then fix R2 to the Front board and fix R1 to the top of the storage box with Nails S by using Allen key A. Please notice that we mark the position with white drawing.

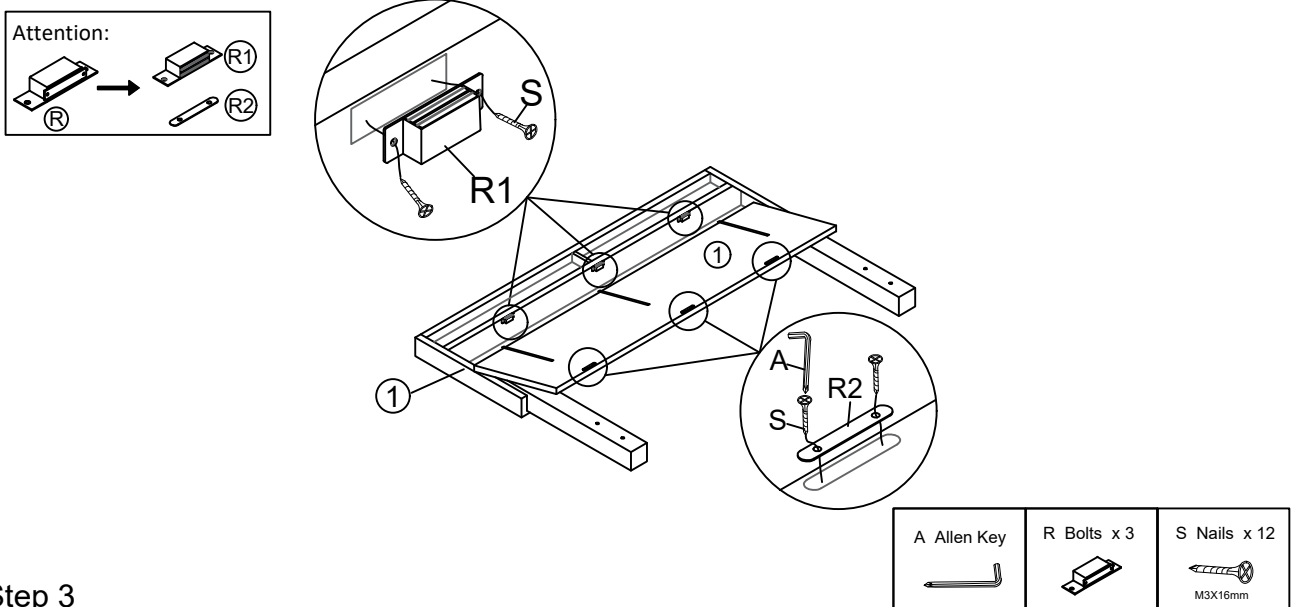

### Step 3

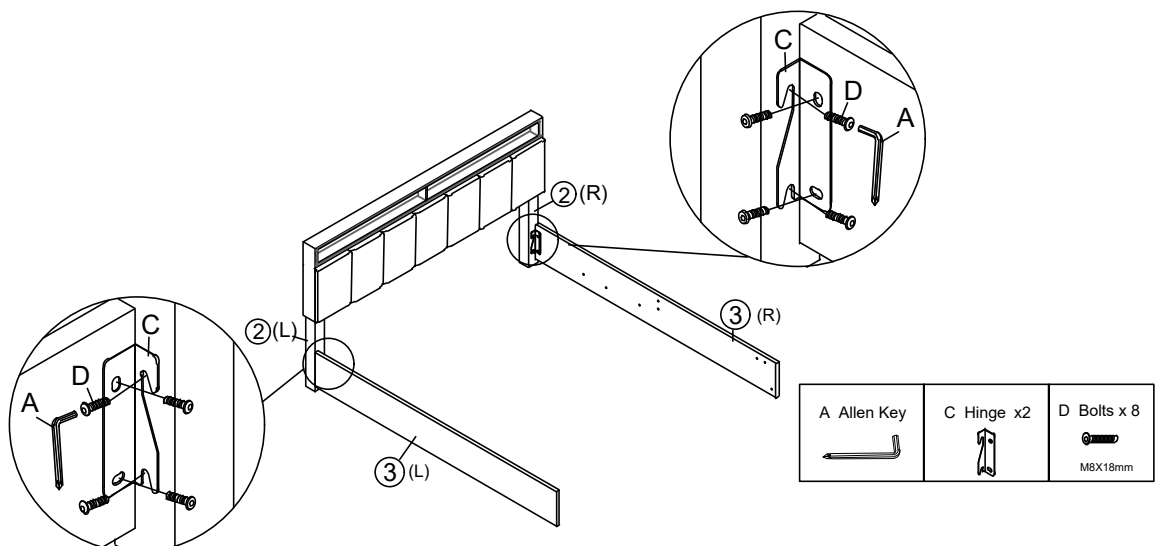

Fix the side rails ③ to the side head board legs ② with Bolts D and Hinges C by using Allen key A .

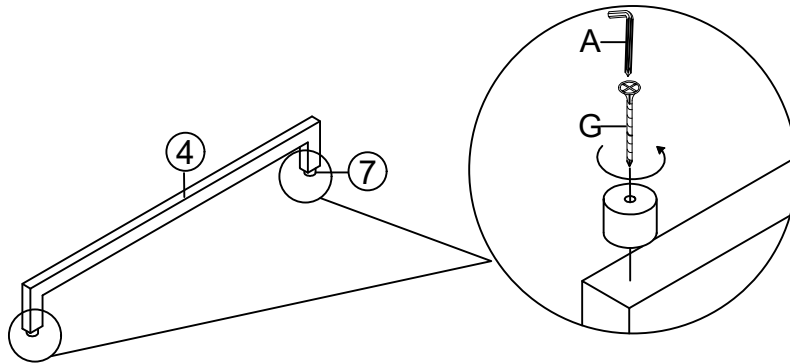

## Step 4

Fix the legs ⑦ to the foot board ④ with Nails G by using Allen key A or electric drill .





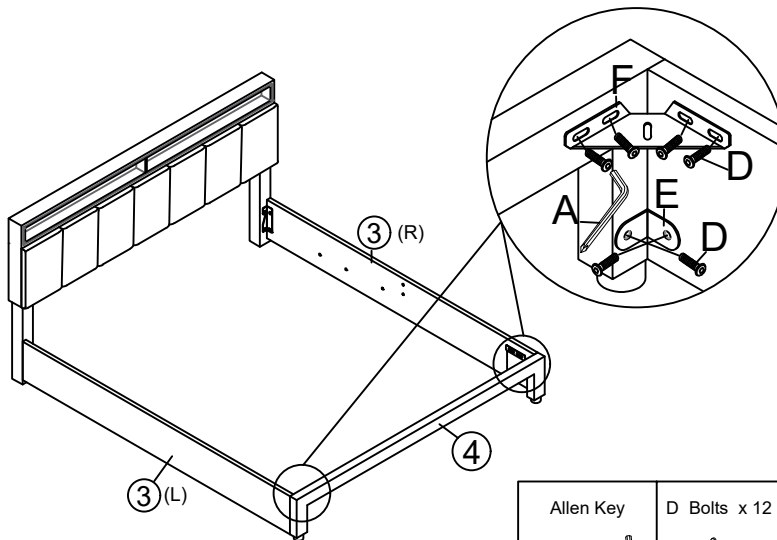

A Allen Key	G Nails x2
	 M4X50mm

## Step 5

Fix the Siderails ③ to the footboard ④ with Metal corner F, Little "7" Connector E and Bolt D by using Allen key A.





Allen Key	D Bolts x 12	E Little "7" Connector x 2	F Metal Corner x 2
	 M8X18mm		

## Step 6

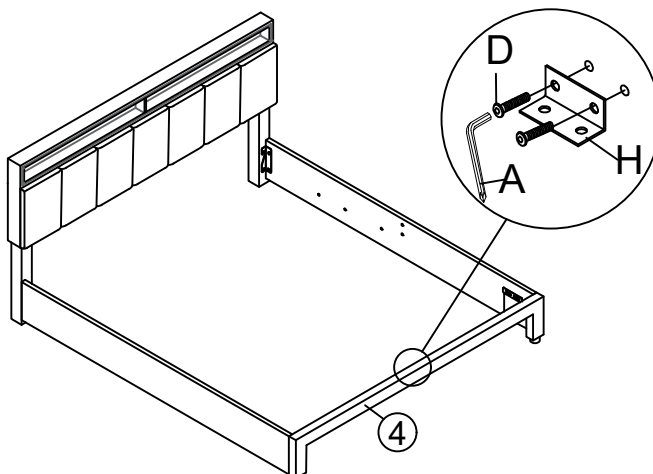
Fix the "7" Connector H to the footboard ④ with Bolt D by using Allen key A.



Allen Key	D Bolts x 2	H "7" Connector x 1
	 M8X18mm	

## Step 7

Fix the gas lifts ⑥ to the Siderails ③ with Bolts D by using Allen Key A or electric drill. fix the gas bar to the gas lifts ⑥ with Nuts I.

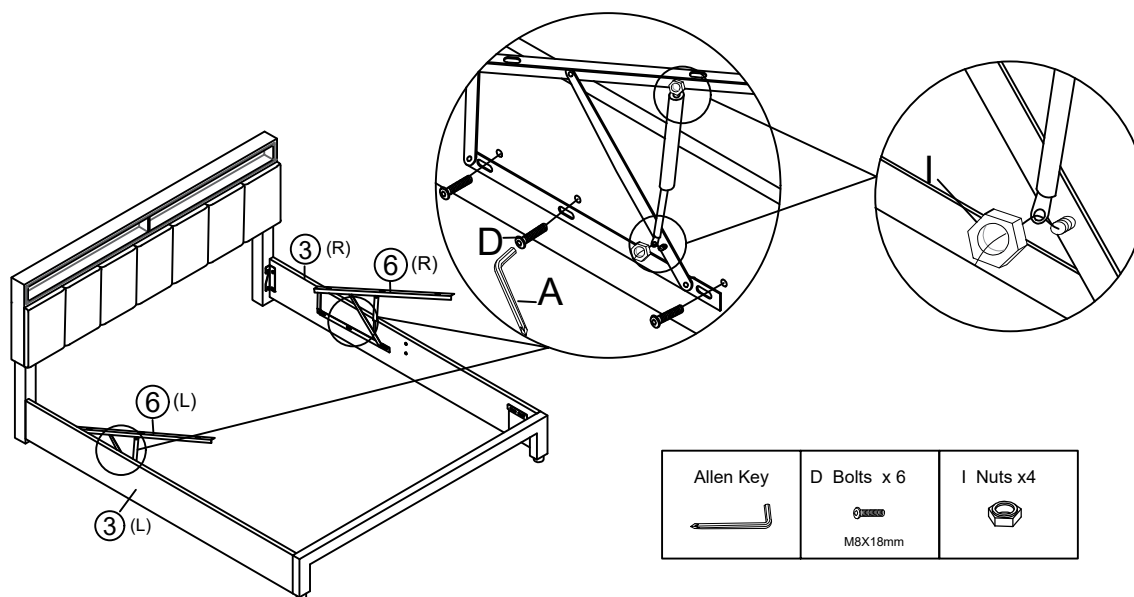

### NOTICE:

The hole on the gas list is oval, please make sure that Please ensure that the installation positions on the left and right are roughly the same, if you accidentally install the gas lift one side to the front and the other to the back, which affects your use, you can write it down and reinstall it.

## Step 8

Fix the cross bar ⑤ to the Siderails ③ with Bolts D by using Allen Key A.

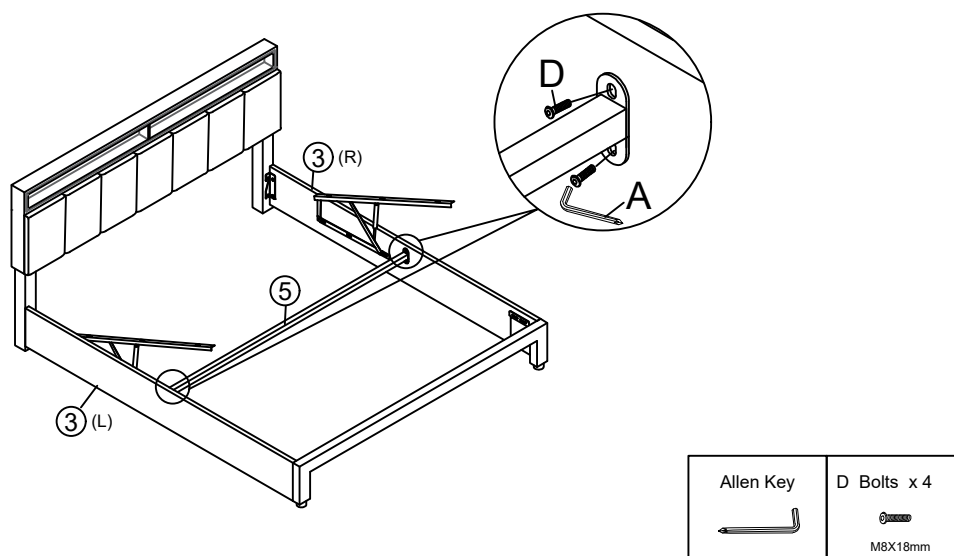

## Step 9

Assemble the slats frame with Bolts B and Nuts K by using Spanner J and Allen Key A.

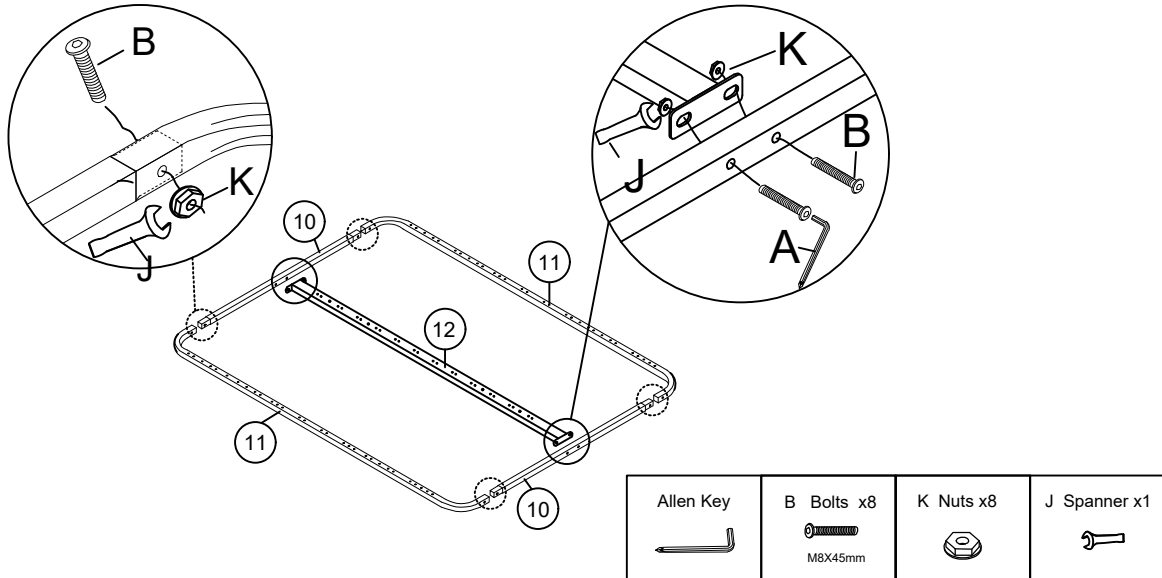

## Step 10

Fix the Middle support leg (13) to the Metal frame middle bar (12) with Bolts B by using Allen Key A.

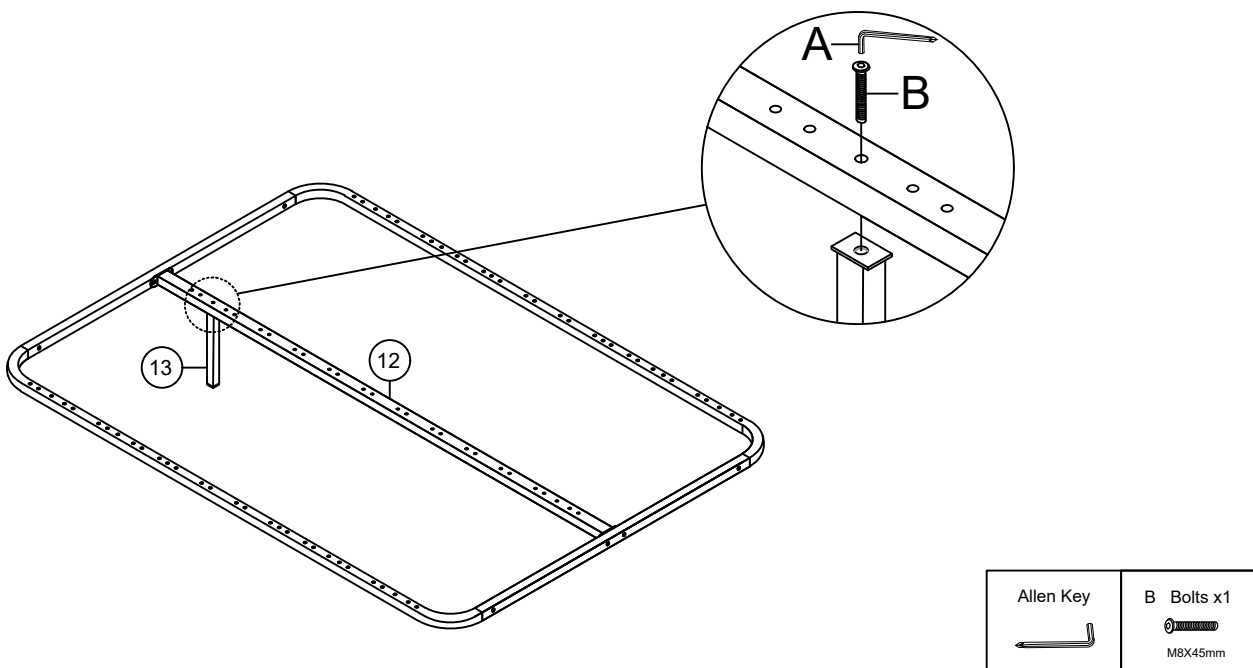

## Step 11

Assemble the slats into the assembled slats frame with middle slats cap L and end slats cap M.

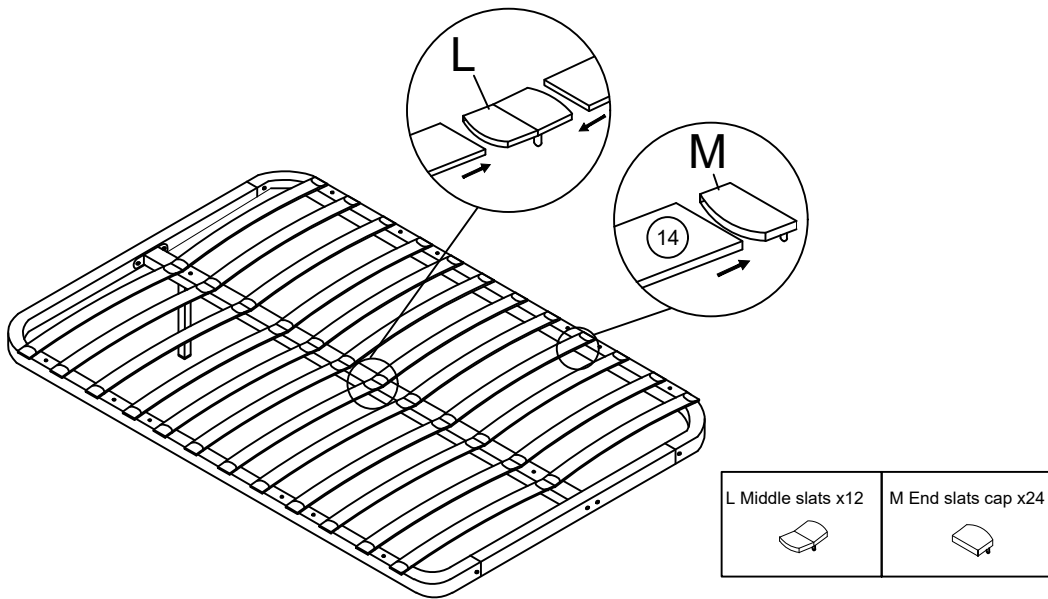

## Step 12

Assemble the slats frame to the gas lifts ⑥ with Bolts B and Nuts K, put the stopper N in the end of the slat frame.

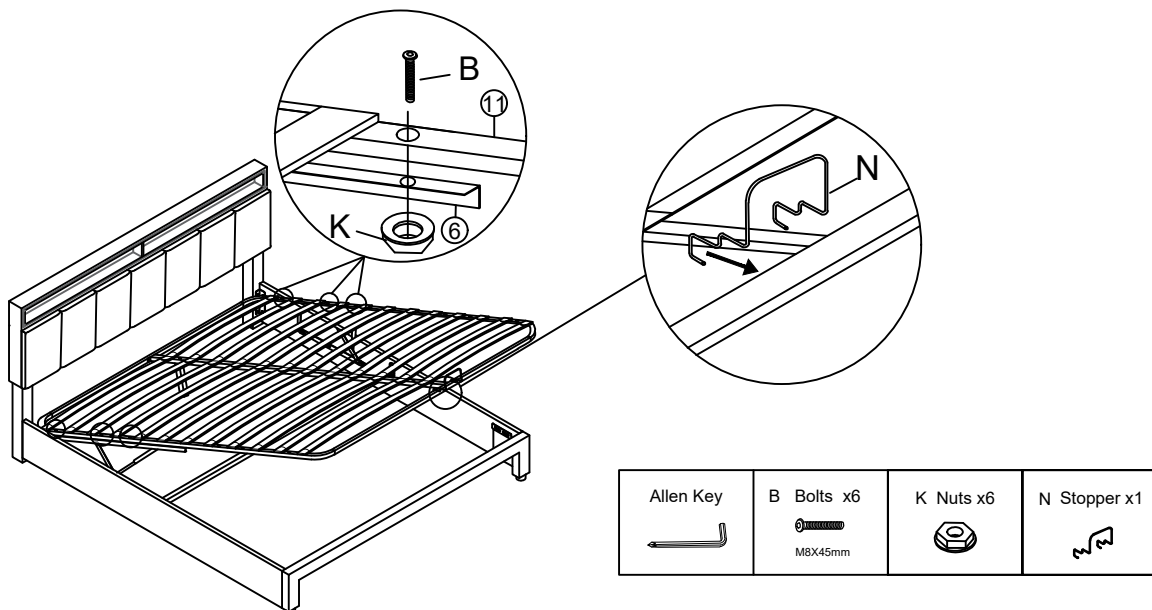

## Step 13x2

Assemble the Drawer ⑨ with Drawer fittings Q(Please separate Q1 and Q2 first).  
Fix the Drawer out board ⑧ to the Drawer ⑨ with Drawer fittings P and Bolts D by using Allen key A.

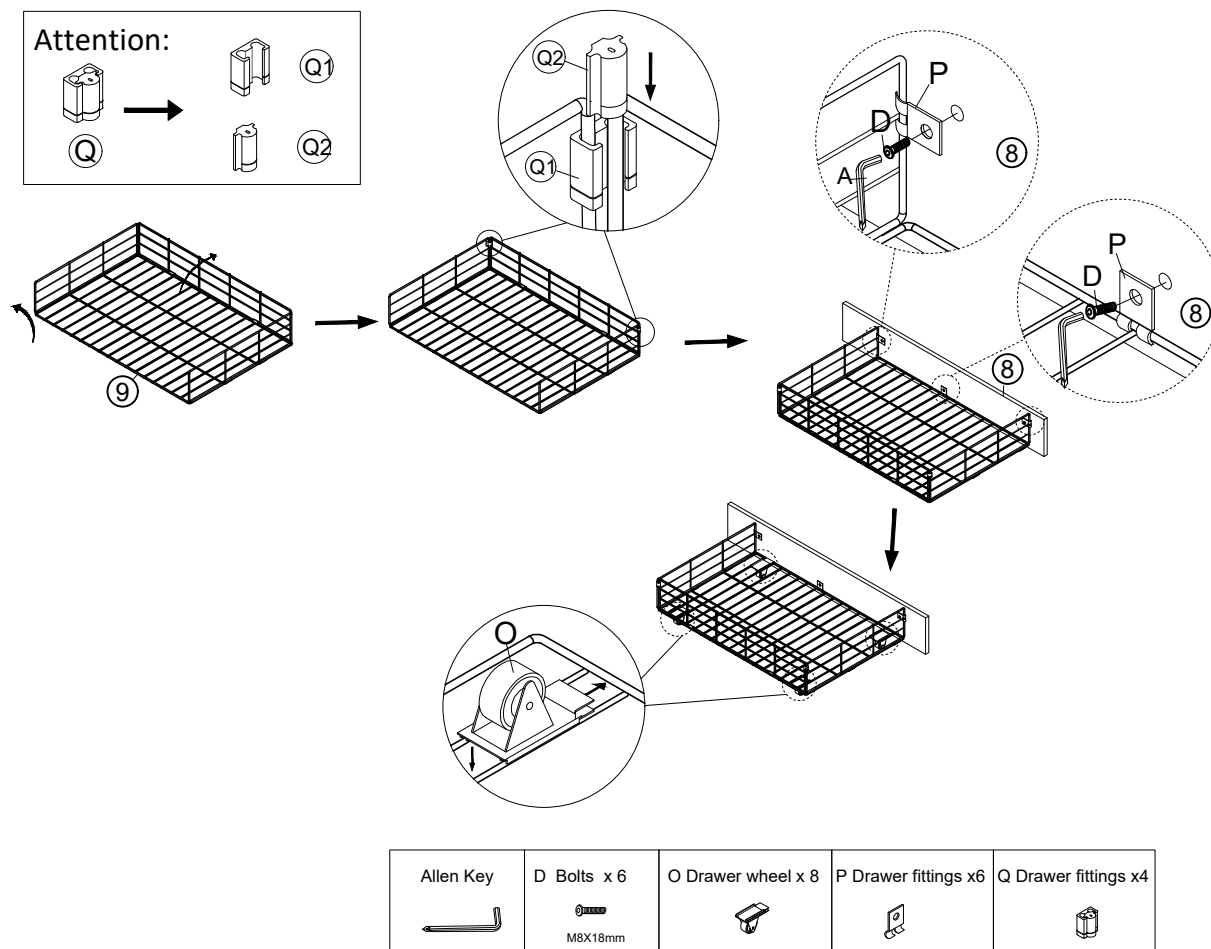

## Step 14

Put the color controller U to the light line ,please notice that → ←. Fix the Led adapter T to the Color controller U, Finally connect the power. Push the drawers into the bed, then assembly is finished and please enjoy your bed.

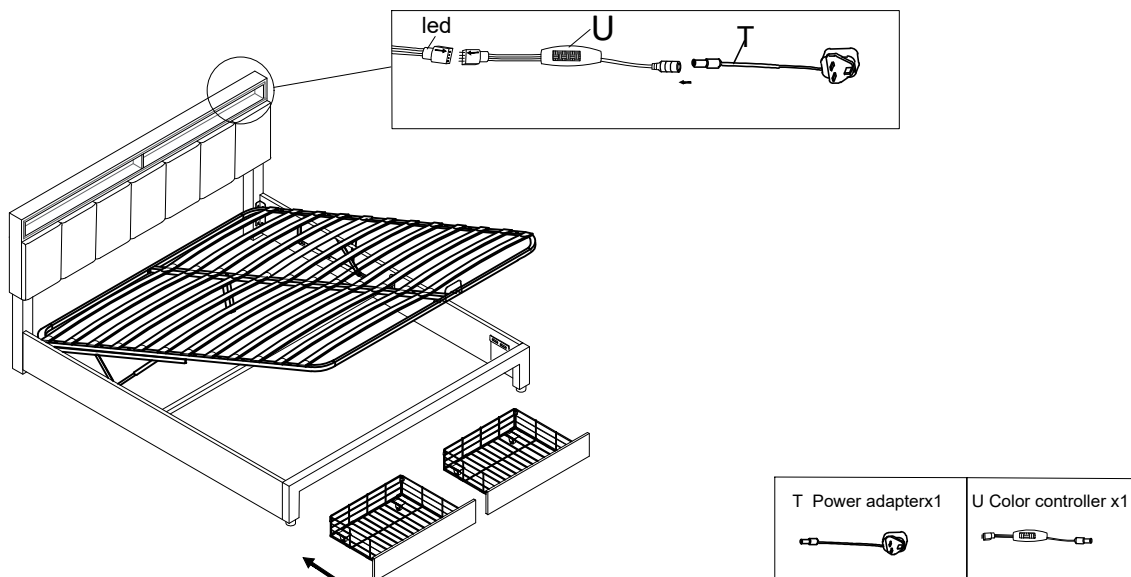

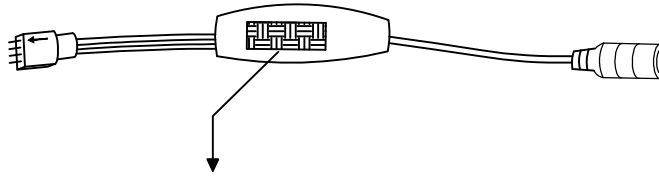

**NOTICE:**

You can scan the QR code here and download an app that can control the color of the light strip like a remote control.  
 When your phone plays music through the app, the color of the light strip will also change according to the strength of the music

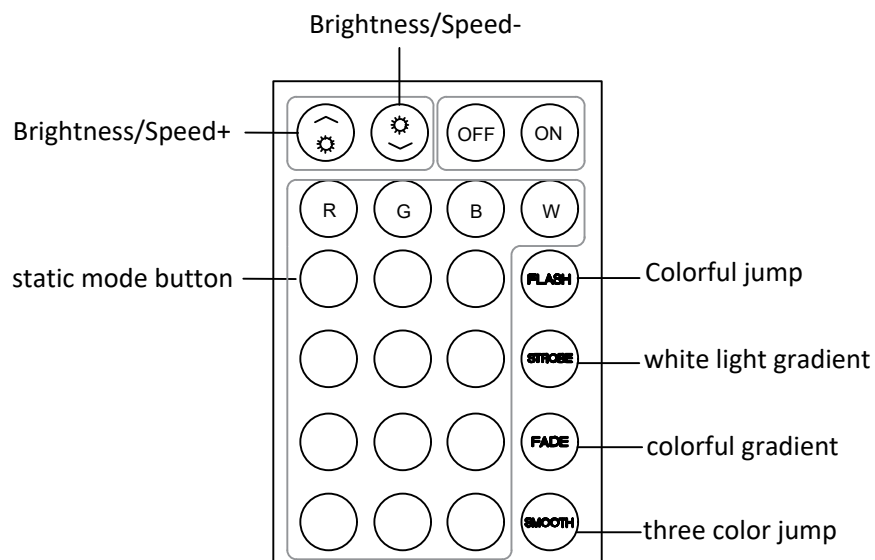

**NOTICE:**

When you use the remote control board to control the color of the light, Please remove the clear plastic card first, then please be sure to point the remote control at the color controller .

**GB** – NOTE: The battery in the remote control requires you to purchase and install it yourself.  
Model: CR2025 3.V

**DE** – HINWEIS: Die Batterie in der Fernbedienung müssen Sie selbst kaufen und installieren  
Modell: CR2025 3.V

**FR** – REMARQUE : la pile de la télécommande doit être achetée et installée par vos soins.  
Modèle : CR2025 3.V

**IT** – NOTA: la batteria del telecomando deve essere acquistata e installata autonomamente.  
Modello: CR2025 3.V

**ES** – NOTA: La pila del mando a distancia debe comprarla e instalarla usted mismo  
Modelo CR2025 3.V



Modell : CR2025 3.V



# Attestation of Compliance

<b>Declaration No.:</b>	MK23110141P01-E01
<b>Name and address of Applicant:</b>	<b>Shenzhen Hongzhengyu Technology Co., LTD</b> Shenzhen baoan district rock street industrial science and technology industrial park of 2 Haitian lanyu 3 5 floor of A
<b>Name and address of Manufacturer:</b>	<b>Shenzhen Hongzhengyu Technology Co., LTD</b> Shenzhen baoan district rock street industrial science and technology industrial park of 2 Haitian lanyu 3 5 floor of A
<b>Product name:</b>	<b>RGB package</b>
<b>Rated:</b>	DC5V
<b>Product model(s):</b>	HZY-5050RGB-30D-90R-DC5V, HZY-5050RGB-30D-30R-DC5V, HZY-5050RGB-60D-60R-DC5V, HZY-5050RGB-60D-180R-DC5V, HZY-5050RGB-18D-18R-DC5V
<b>Product trademark:</b>	N/A

This Attestation of Compliance confirms that the product meets the requirements of the following standard.

BS EN IEC 55015:2019+A11:2020  
IEC 61547:2020  
BS EN IEC 61000-3-2:2019  
BS EN 61000-3-3:2013/A2:2021

*The Attestation of Compliance has been carried out in accordance with individual rules and conditions agreed with the applicant. Evaluation has been carried out in accordance with:*

<b>Test report(s) No.:</b>	MK23110141P01-E01
<b>Test conducted by:</b>	TMC Testing Services (Shenzhen) Co., Ltd.
<b>Declaration issue date:</b>	December 5, 2023

**Notes:**

*This Attestation of Compliance is issued according to the Great Britain legislation Electromagnetic Compatibility Regulations 2016( SI 2016 No. 1091). It confirms that the listed products complies with all essential requirements of the Regulations and applies only to the sample and its technical documentation to TMC Testing Services (Shenzhen) Co., Ltd. for testing.*

*After preparation of the necessary technical documentation (which must be kept for up to 10 years after the product is placed on the GB market) as well as the UK Declaration of Conformity, the required UKCA marking can be affixed on the product. Other relevant Regulations have to be observed.*

**TMC Testing Services (Shenzhen) Co., Ltd.**

t:86-755-86642861 cert@tmc-lab.com www.tmc-lab.com

1st Floor, Block A1, Zone A, Xinshidai Gongrong Industrial Park, No. 2, Shihuan Road, Shiyuan Street, Baoan District, Shenzhen, China



**UK  
CA**



# CERTIFICATE OF CONFORMITY

## Electrical Equipment (Safety) Regulation 2016

This Certificate of Conformity is hereby issued to the product designated below:

**Certificate No.** ..... : 21SP12116L01  
**Report No.** ..... : SP2112116L01  
**Date Issue.** ..... : 2022-01-21  
**Applicant's name** ..... : Huizhou Guoatong Technology Co., Ltd  
**Address** ..... : 4F(plant E), 4F(Plant C), 4F&5F(plant B), 2 Runze Rd. Huinan South High-tech Industrial Park. Huiao Avenue. Huizhou, Guangdong, China  
**Manufacturer's name** ..... : Same as applicant  
**Address** ..... : Same as applicant  
**Product Description** ..... : POWER ADAPTER  
**Model(s)/Type References** : GA-XXXYYYYW, GAT-XXXYYYYW  
("XXX", "YYYY" and "W" are variables, see following page for details)  
**Parameters** ..... : Input: 100-240V~, 50/60Hz, 0.6A  
Output: 3.0-24.0Vdc, 0100-2000mA, 12.0W Max.  
**Standard(s)** ..... : BS EN 62368-1:2014+A11:2017

On the basis of the referenced test report(s), sample(s) tested of the above product have been found to comply with the standards harmonized with the directives listed on this verification at the time the tests were carried out. Other standards and Directives may be relevant to the product. This verification is part of the full test report(s) and should be read in conjunction with it(them).

Once compliance with all product relevant CE mark directives are verified, including any relevant e.g. risk assessment and production control, the manufacturer may indicate compliance by signing a Declaration of Conformity themselves and applying the mark to products identical to the tested sample(s).

Approved By

  
Eric Liu  
Director of engineering department



# CERTIFICATE OF CONFORMITY

Electrical Equipment (Safety) Regulation 2016

Appendix of Certificate No.: 21SP12116L01

Table A: Definition of variables

Variable:	Range of variable:	Content:
XXX	030-240	Which stands for the rated output Voltage from 3.0Vdc to 24.0Vdc, minimum step by 0.1 Vdc.
YYYY	0100-2000	Which stands for the rated output current from 100mA to 2000mA, minimum step by 100mA.
W	V, Y	"V" "Y" means UK plug

Table B: Model list and output rating

Model	Rated output voltage (VDC)	Rated output current (mA)	Max. rated output power (W)	Transformer (T1)
GA-XXXYYYYYW, GAT-XXXYYYYYW	3.0-5.0	0100-2000	10.0	EF15-5V
	5.1-12.0	0100-1000	12.0	EF15-12V
	12.1-24.0	0100-1000	12.0	EF15-24V

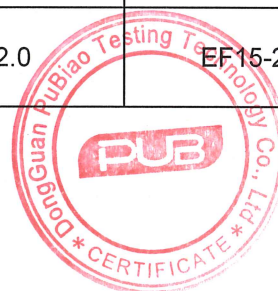

DongGuan PuBiao Testing Technology Co., Ltd

No. 3, First Floor, Building A, No.30, Minghua Road, Juzhou village, Shijie Town, Dongguan City Guangdong China

Tel: +86 769 81813516 E-mail: [service@pubiaotest.com](mailto:service@pubiaotest.com) Web: [www.pubiaotest.com](http://www.pubiaotest.com)

Question: What to do if the slat frame is tilted?

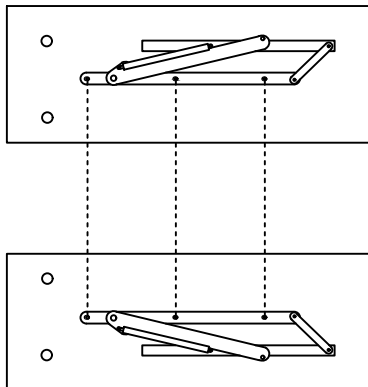

Answer:

The hole on the hydraulic rod is oval. Please make sure that the installation positions on the left and right sides are the same. If you accidentally install one side of the hydraulic rod in the front and the other side in the back, the slat frame will be crooked and you will need to disassemble it and reinstall it.

Question: What to do if the hydraulic system fails to press down?

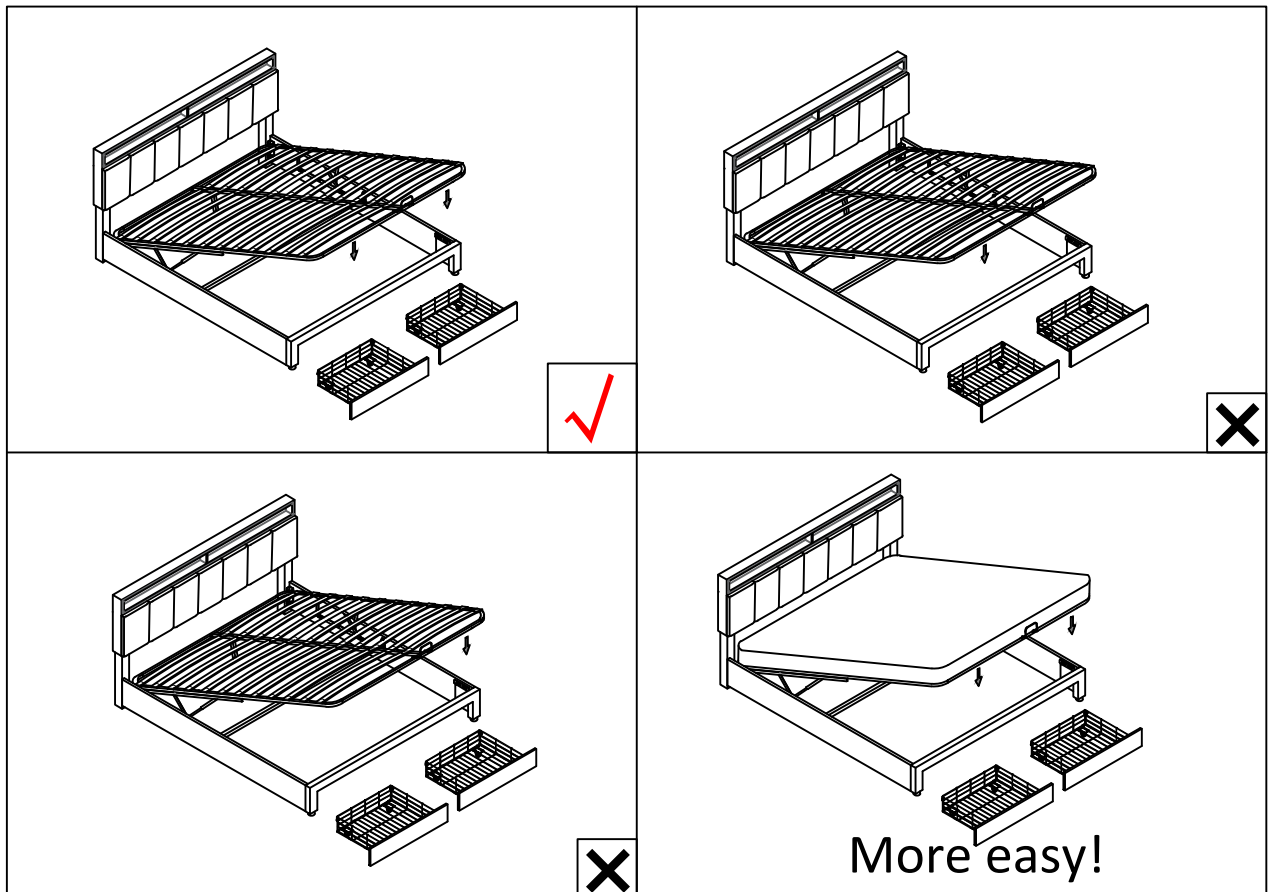

Answer:

When turning off the hydraulic pressure, make sure that the pressure point is at the position indicated by the arrow. Place your hand at the pressure point.

If you place the mattress on a slatted frame, it will be easier to turn off the hydraulic pressure. Please try it.

Do not press only on the left side or only on the right side, as this will damage the hydraulic system.