

OFFICE CHAIR SQUARE BACK

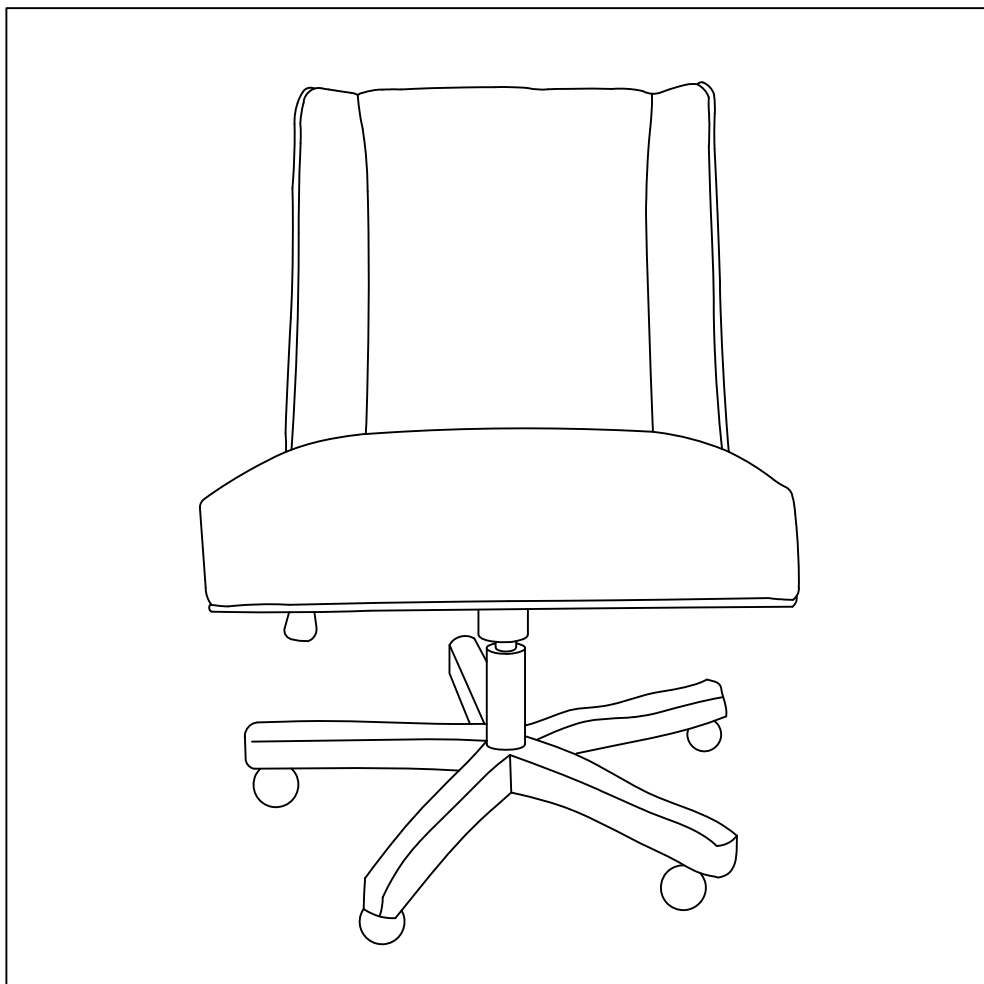

We are here to help! Before you return it - contact us.

We do our best to insure that your furniture arrives in excellent condition. In the event that a part is damaged or missing, we will be happy to provide you with replacement parts, at no charge, within 30 days of purchase, providing the parts are available in our warehouse and the item purchased is part of our current inventory. In order to receive spare parts, at no charge, you must provide proof of purchase within 30 days.

If you need assistance with assembly or replacement parts, please call Customer Service, prior to returning the item to the store.



Or visit our web site to order spare parts and for care instructions on your newly purchased furniture.

Part List

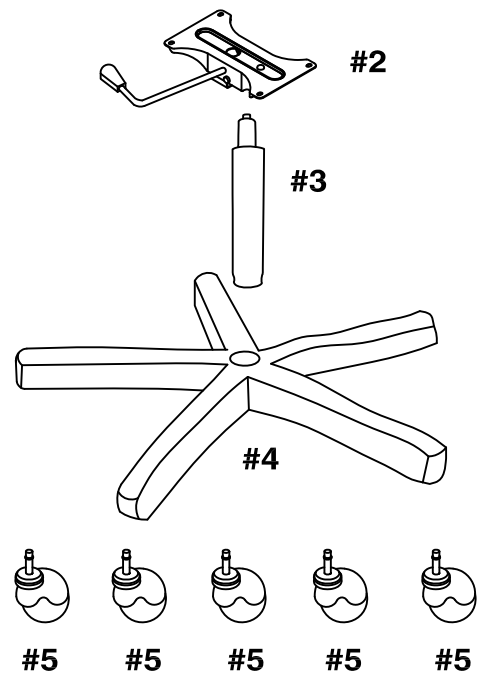
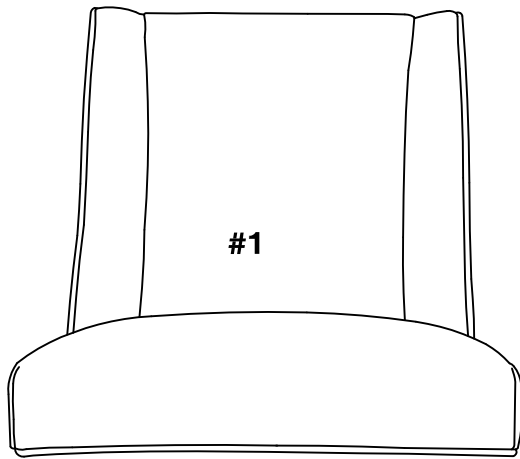
#1	Seat	01
#2	Mechanism	01
#3	Gaslift	01
#4	Base	01
#5	Caster	05



Hardware List

A	Bolt(Ø5/16"x1-3/16")		04
B	Flat washer		04
C	Spring washer		04

Tools required

Allen key		Supplied
-----------	---	----------

IMPORTANT:

1. Do not tighten bolts completely until all bolts are completely lined up and inserted into holes / nuts.
2. Do not over tighten screws and bolts to avoid stripping.
3. Please use hand tools to assemble this product. Do not use power tools.

1.

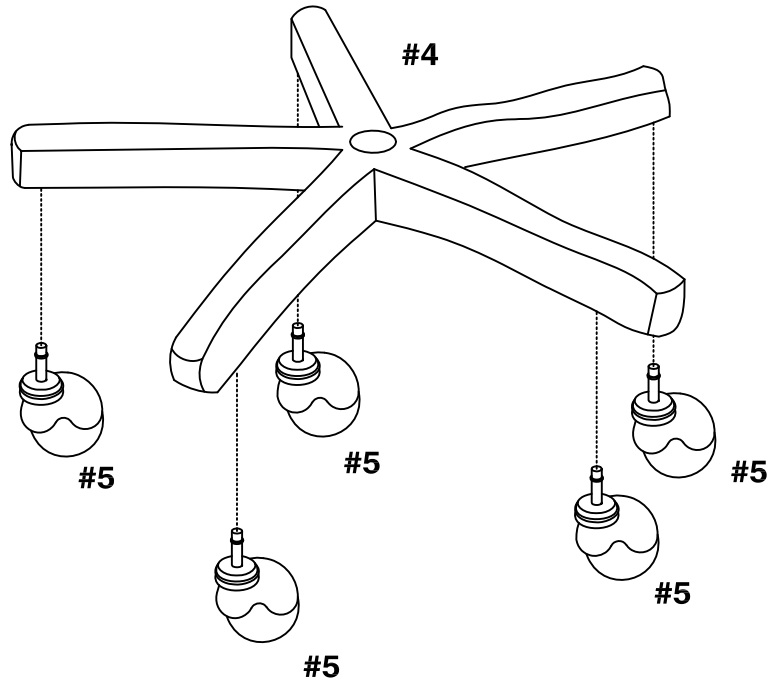



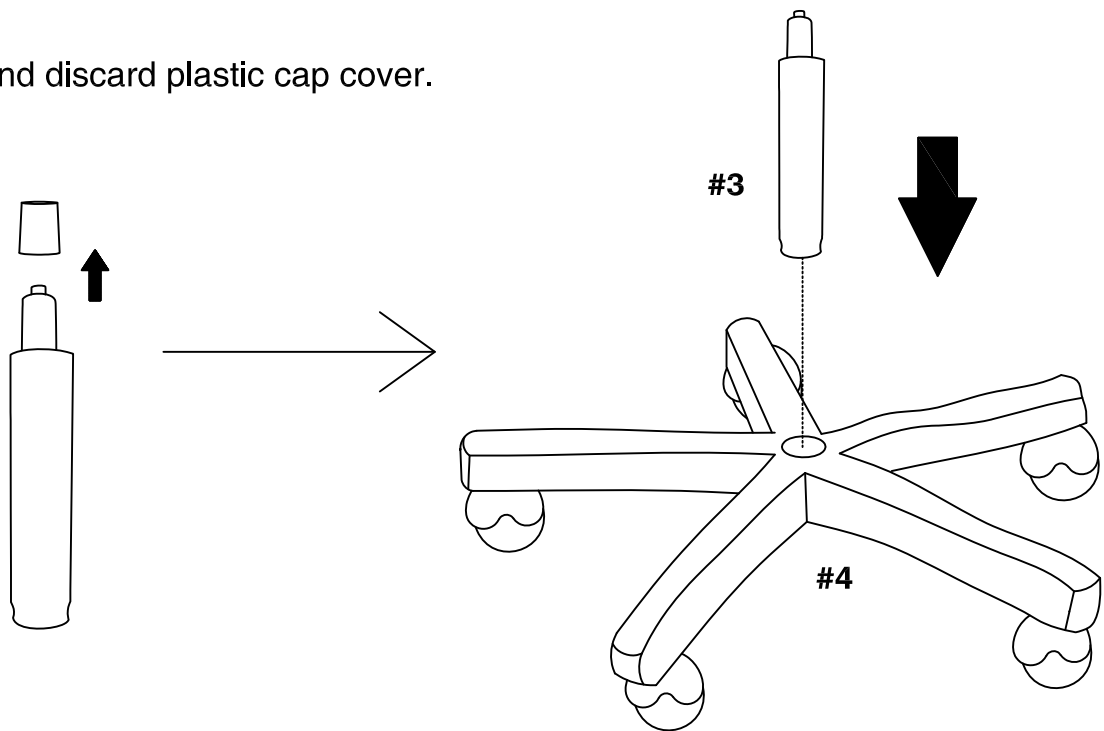

2.

Remove and discard plastic cap cover.

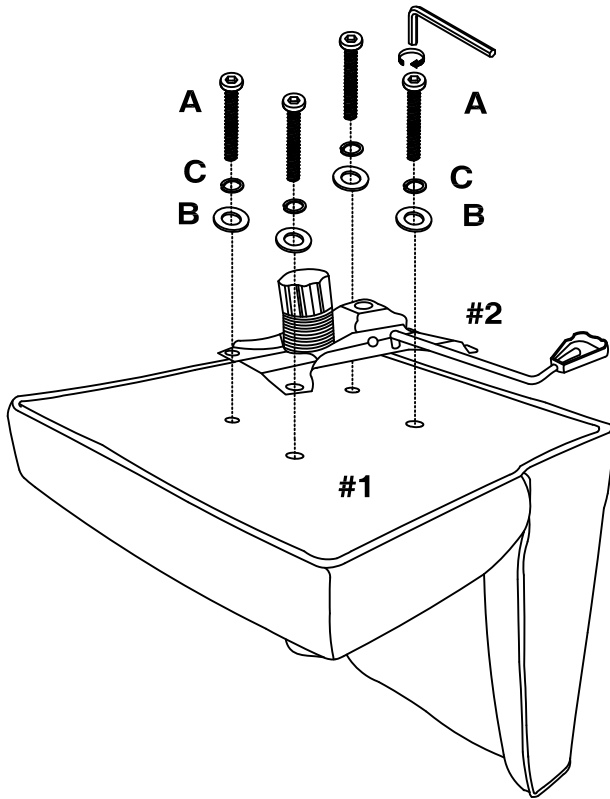

3.



A		04
B		04
C		04

4.

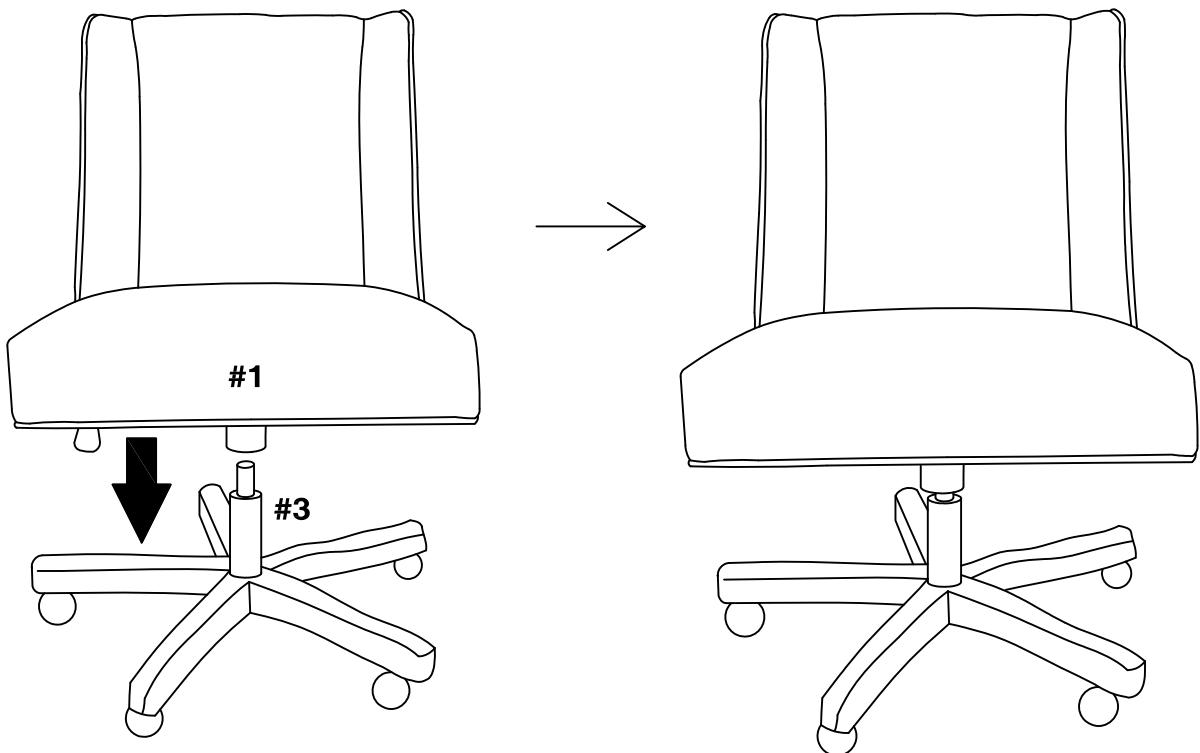

LIMITED 6 MONTHS WARRANTY
GARANTIE LIMITÉE DE 6 MOIS
GARANTÍA LIMITADA DE 6 MESES

WHAT IS COVERED

This product is covered under our manufacturer's 6 months limited warranty. To ensure your complete satisfaction, this warrants to the original purchaser that the supplied item is free from defects in material and workmanship, as of the date of purchase, and that it will, under normal use and proper care, remain so for six months after the date of purchase. Replacement of missing or initially defective parts will be sent, at no charge, for a period of 30 days from the date of purchase with valid proof of purchase providing the parts are available in our warehouse and the item purchased is part of our current inventory.

WHAT IS NOT COVERED

It remains the customer's responsibility for freight and packaging charges to and from the customer service center. Labor and material charges to remove or replace parts under this warranty are not covered.

This warranty does not cover: Furniture used for commercial purposes, failures caused by improper installation assembly or by improper care, unreasonable or abusive use, freeze damage, acts of God, rust, purchased parts or return freight and packaging charges. Proof of purchase (dated register receipt) is required for warranty claims.

HOW TO OBTAIN SERVICE

For further information, please contact our customer service department.

MADE IN CHINA
FABRIQUÉ EN CHINE
FABRICADO EN CHINA