

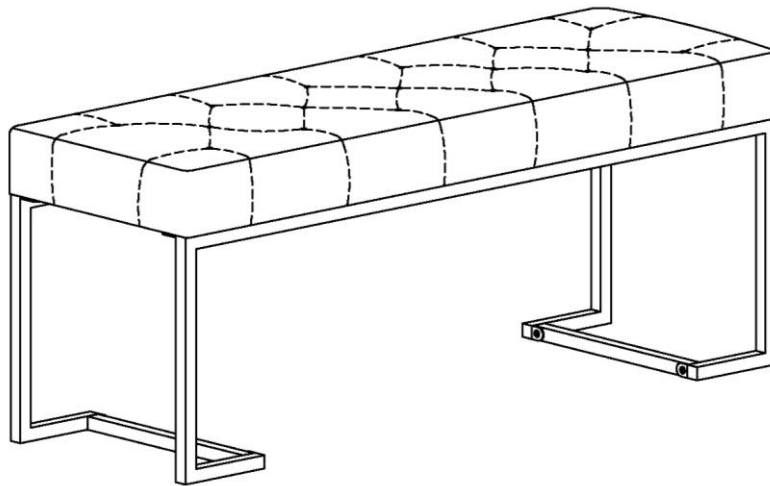

Assembly Instructions

Caution : You must read this before you proceed



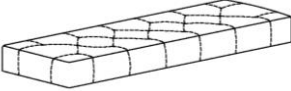
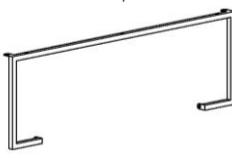

Bench

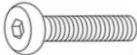

Parts List

Label	Picture	Description	QTY
A		Bench Base	1
B		Metal Leg (with Pre-installed Levellers)	2
C		Iron Pipe	2

Hardware

Label	Picture	Description	QTY
①		Bolt (M6*20mm)	9
②		Bolt (M6*55mm)	7
③		Spring Washer (M6)	15
④		Washer (M6*Φ16)	15
⑤		Allen Wrench (M4)	1

Assembly Preparation

Before Beginning Assembly:

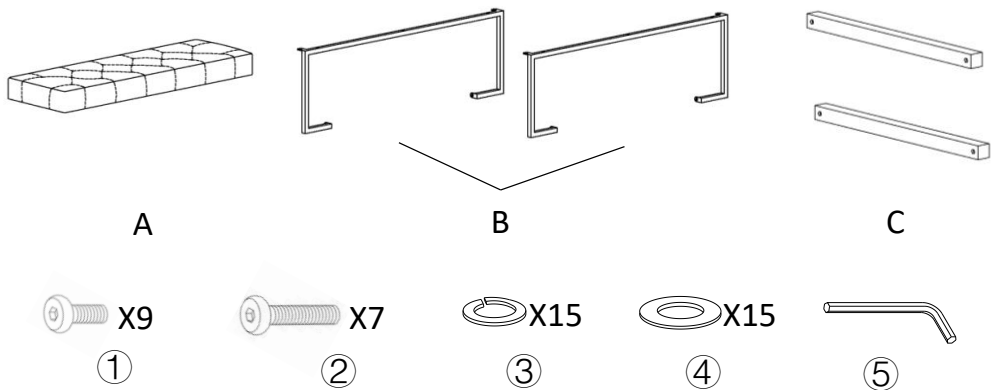

- Read instructions, cover to cover-



- Have 2 adults on hand for assembly-



- Do not assemble on flooring or carpet-



- Assemble on a clean non-marring surface (packing foam)-



- Save all packaging until finished-

Assembly Steps

Overview

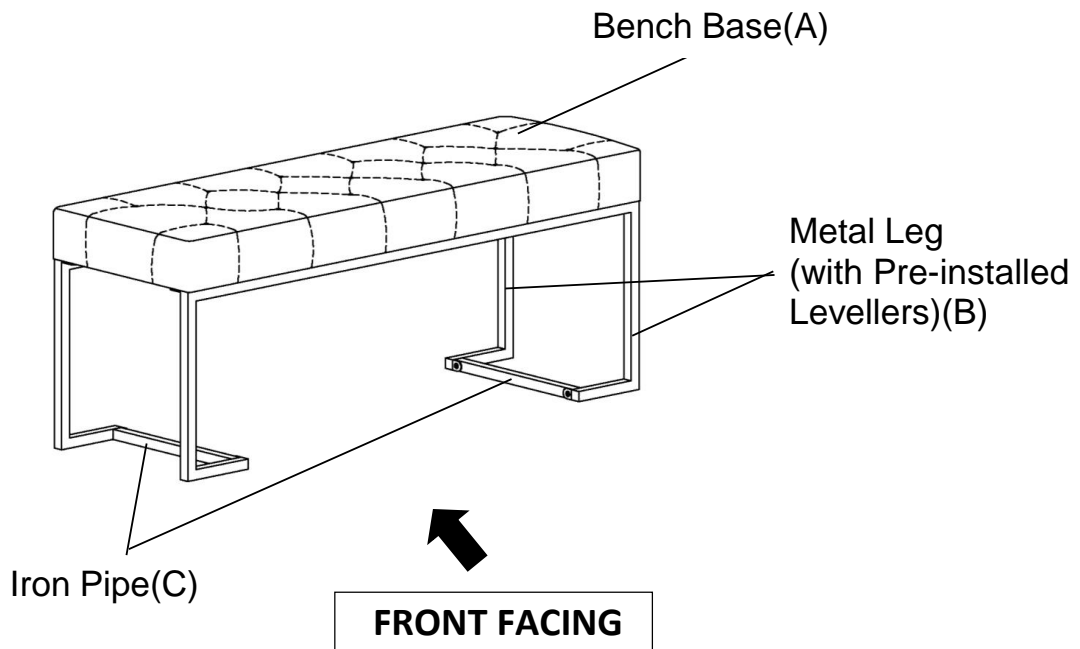

This Bench has multiple parts and may require up to 30 minutes to assemble. To give you an overview of the Bench parts, the above picture is to help you put the various parts into perspective. Please read through the instructions below to familiarise yourself with the parts and steps before assembly.

Step 1

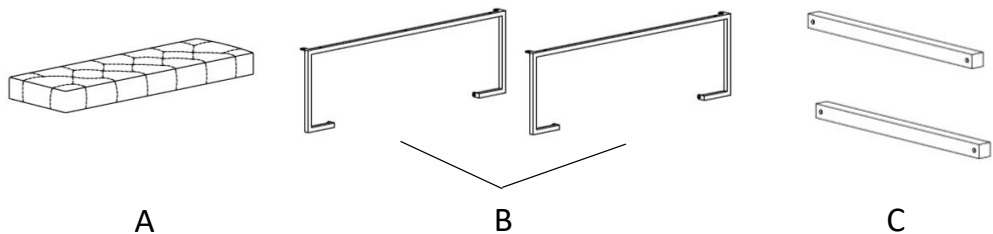

Place the Bench Base(A), Metal Legs(B) and Iron Pipes(C) on a clean, non-marring surface.

Step 2

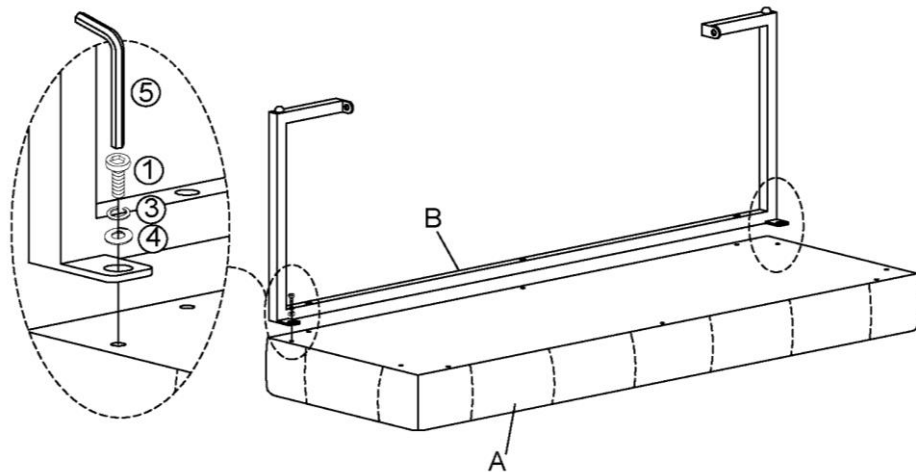

Position the Bench Base(A) facedown as shown. Place the Metal Leg(B) on the Bottom of Bench Base(A) and attach where indicated using Bolts(①), Spring Washers(③) and Washers(④) with the Allen Wrench(⑤).

Note: Do not fully tighten the Bolts in this step.

Step 3

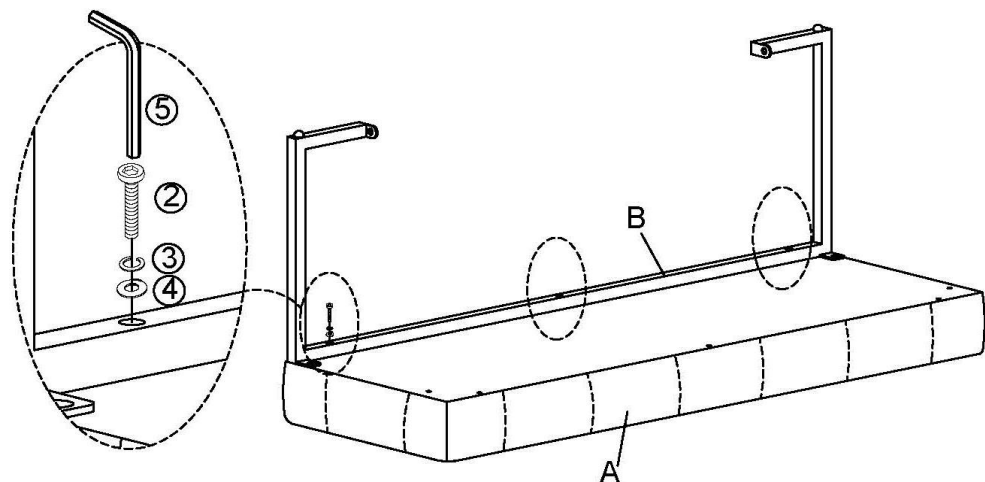

Further Attach Metal Leg(B) to Bench Base(A) where indicated using Bolts(②), Spring Washers(③) and Washers(④) with the Allen Wrench(⑤).

Note: Do not fully tighten the Bolts in this step.

Step 4

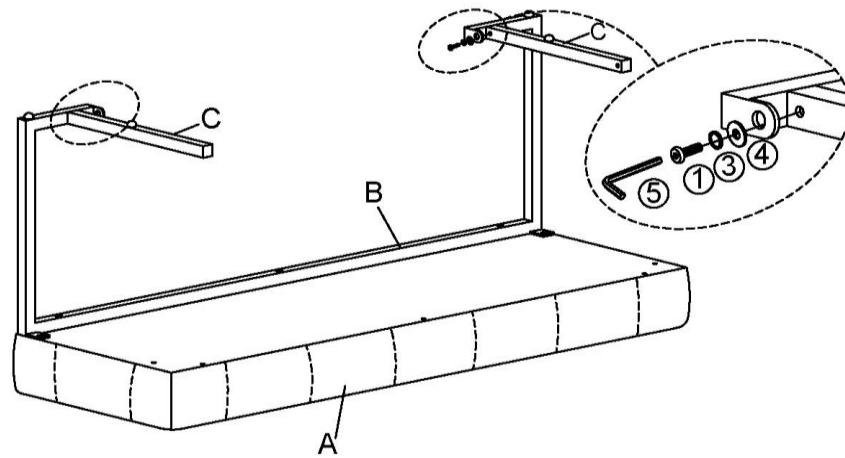

Using Bolts(①), Spring Washers(③), and Washers(④) with the Allen Wrench(⑤) affix the Iron Pipes(C) to the Metal Leg(B).

Note: Do not fully tighten the Bolts in this step.

Step 5

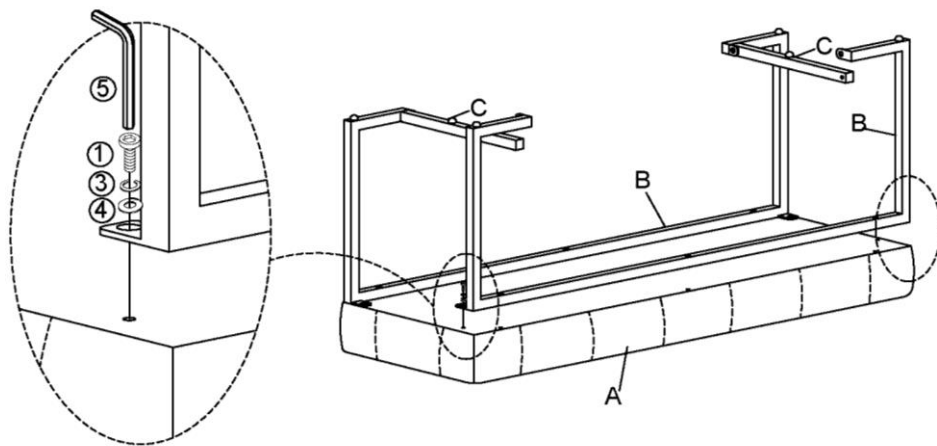

Place the other Metal Leg(B) on the Bottom of Bench Base(A) and attach where indicated above using Bolts(①), Spring Washers(③) and Washers(④) with the Allen Wrench(⑤).

Note: Tighten the Bolts fully in a sequential manner.

Step6

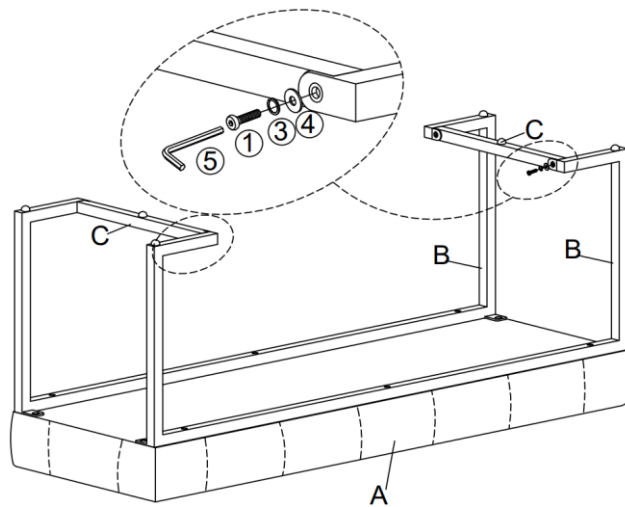

Using Bolts(①), Spring Washers(③), and Washers(④) with the Allen Wrench(⑤) connect the Metal Leg(B) to Iron Pipes(C).

Note: Tighten the Bolts fully in a sequential manner.

Step7

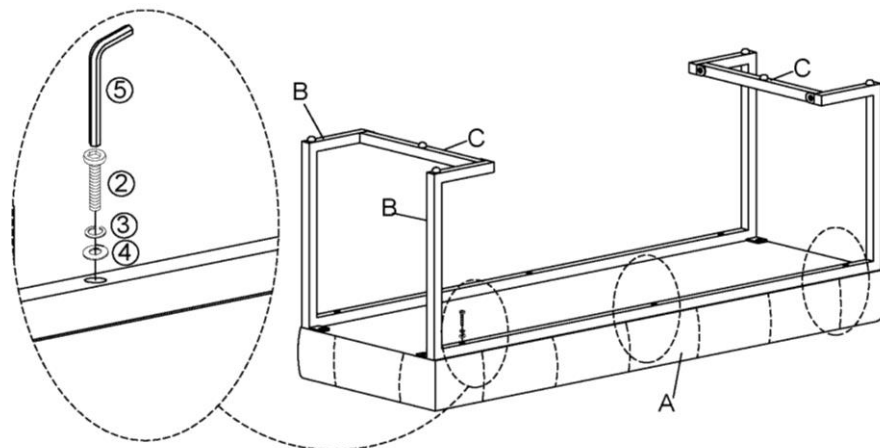

Further Attach Metal Leg(B) to Bench Base(A) where indicated above using Bolts(②), Spring Washers(③) and Washers(④) with the Allen Wrench(⑤).

Note: Tighten all Bolts fully in a sequential manner.

Step8

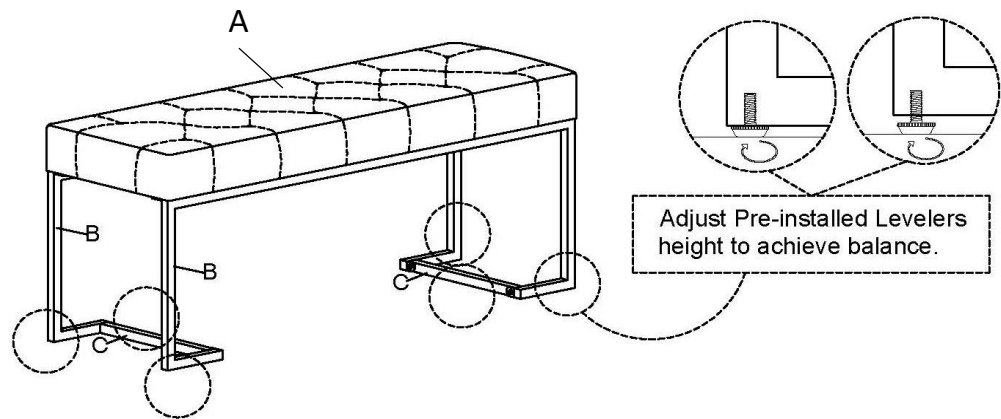

With assistance from an adult partner, stand the Bench up. Adjust the Pre-installed Levelers at the bottom of the Metal Legs (B) until the Bench is level with the ground.

Step9

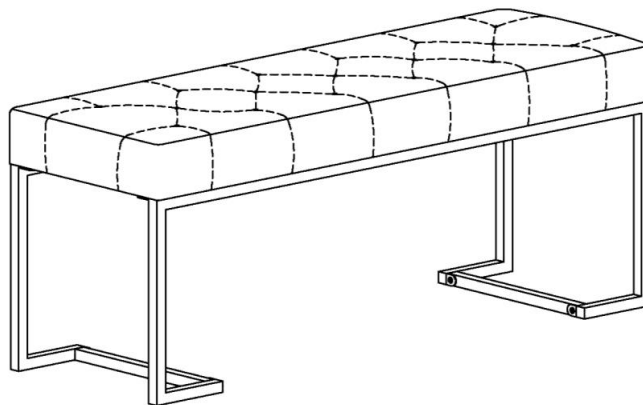

Your Bench is ready for use.
This Bench can only be used on a flat, level surface.

Care & Maintenance



- Furniture may scratch floors. We recommend using furniture pads to protect your floors.



- Do not put hot items directly on furniture surface.



- Do not clean furniture with harsh cleansers or polish.



- Do not place furniture under direct sunlight.



- Do not place furniture near heating or cooling vents.



- Do not write on furniture without a padded barrier to protect the surface.



- Do not place furniture outside . For indoor use only.



- Not for commercial use. For residential use only.



- Stains may be removed with mild soap solution and damp cloth.



- Children should not climb or jump on the furniture.



- Dust and pick-up spills using a clean, non-colored, lint-free cloth.