

Coffee Table

USER' S MANUAL

SKU: LI007501

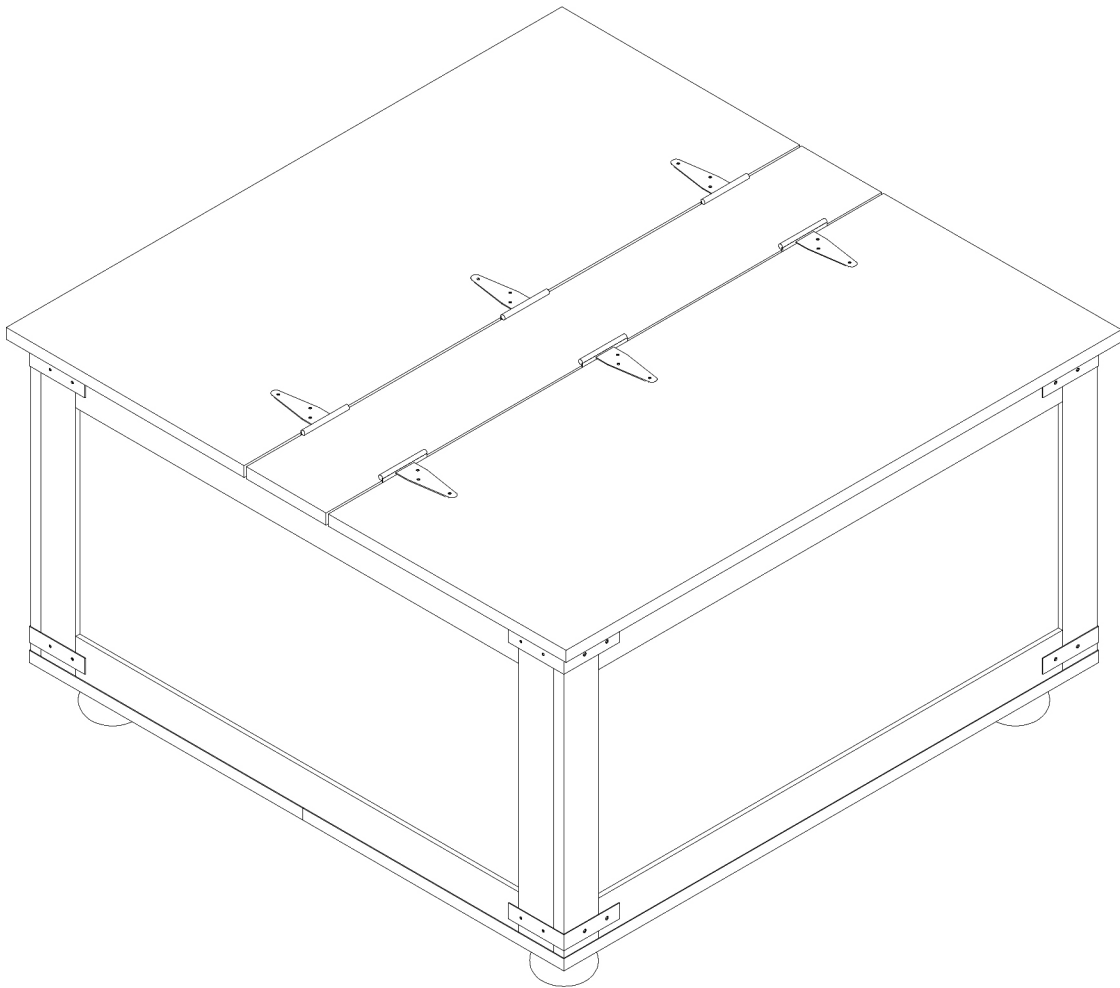

- 1.Ensure that all parts and hardware are available before beginning assembly.
- 2.Follow each step carefully to ensure the proper assembly of the product.
- 3.Two people are recommended for ease in the assembly of this product.
- 4.Before Assembling: Please do not over-tighten all screws to avoid damage to the wood panel.
- 5.Please contact us via the "Contact Seller" button in the detail page of your order for any concern and we'll respond as soon as possible.

BOARD IDENTIFICATION

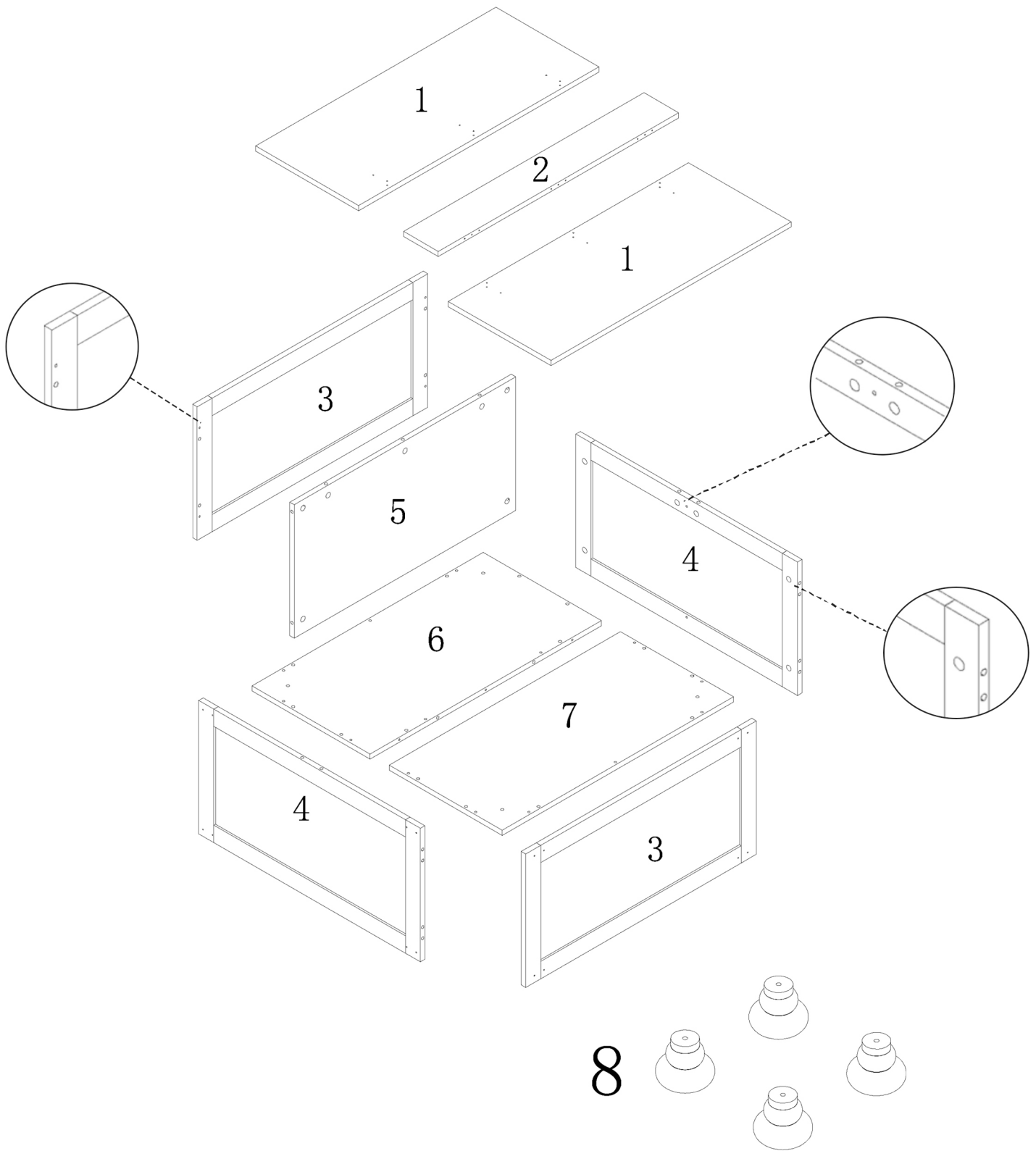

Parts List

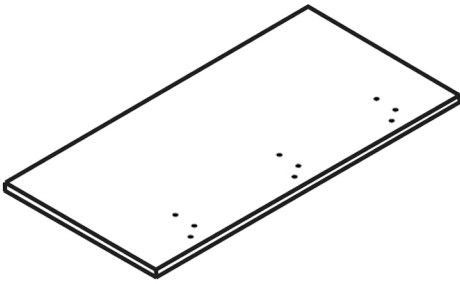

1

2PC

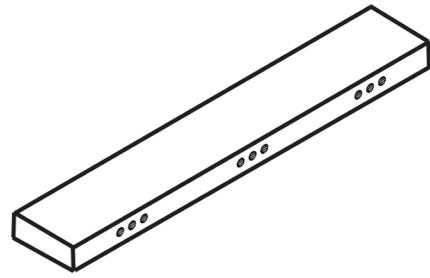

2

1PC

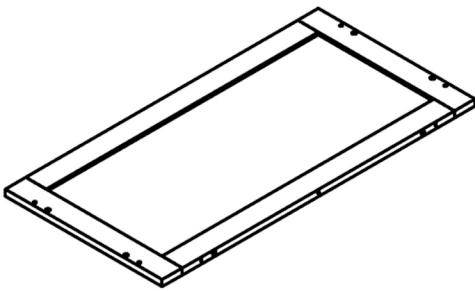

3

2PC

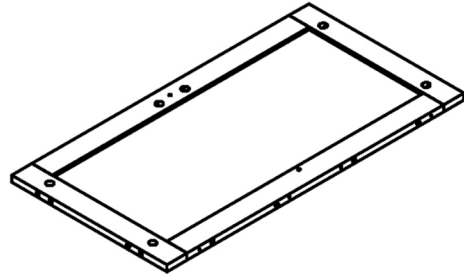

4

2PC

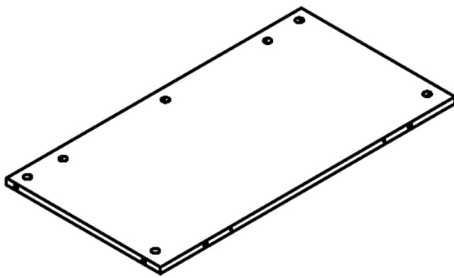

5

1PC

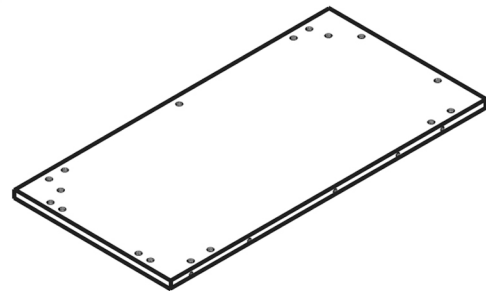

6

1PC

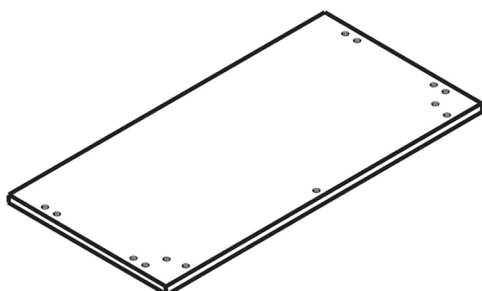

7

1PC

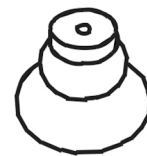

8

4PC

Hardware List

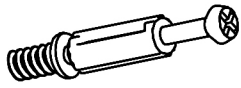

A

22PC



∅15

B

22PC

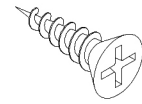

∅3.5*14mm

C

68PC

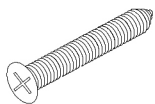

∅4*40mm

D

16PC



∅8*30mm

E

24PC

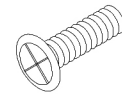

M6*25mm

F

4PC

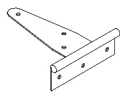

Hinges

G

6PC

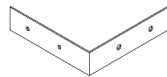

Black Metal Bar

H

8PC

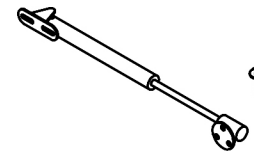

*5PC

Gas Shock Strut Spring

J

4PC



Anti-drop Mat

K

4PC

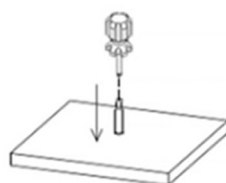
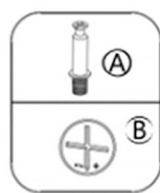

Step 1

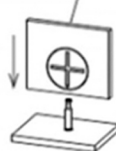
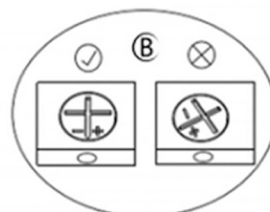

Step 2



Step 3

STEP 1

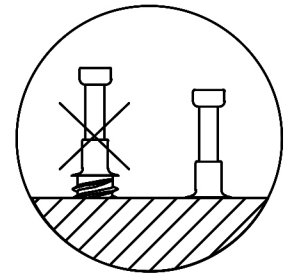
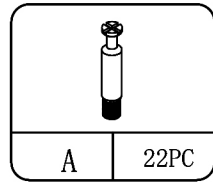

Insert Cam Bolt (A) into Part (2,3,4,6)

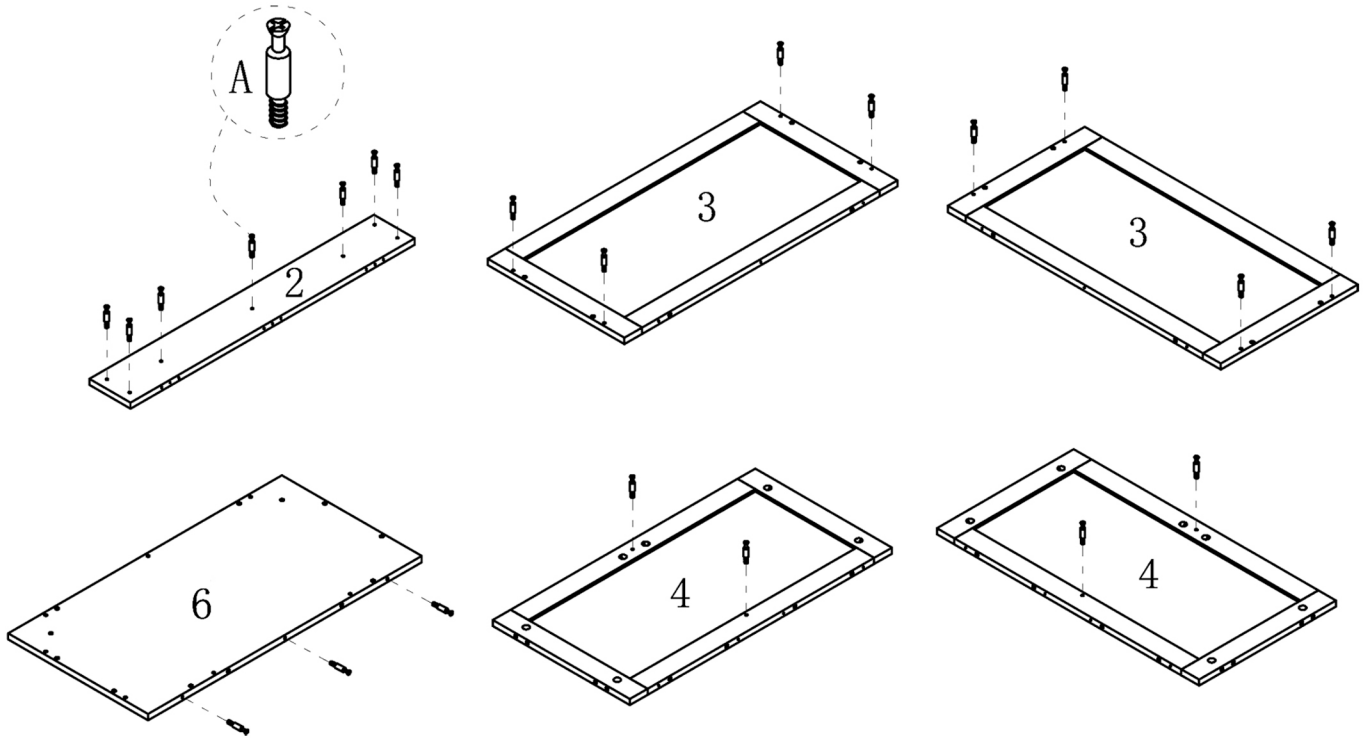

STEP 2

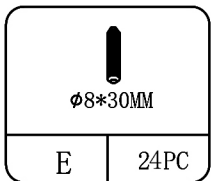

Insert Wooden Dowel (E) into Part (3,4,5,6)

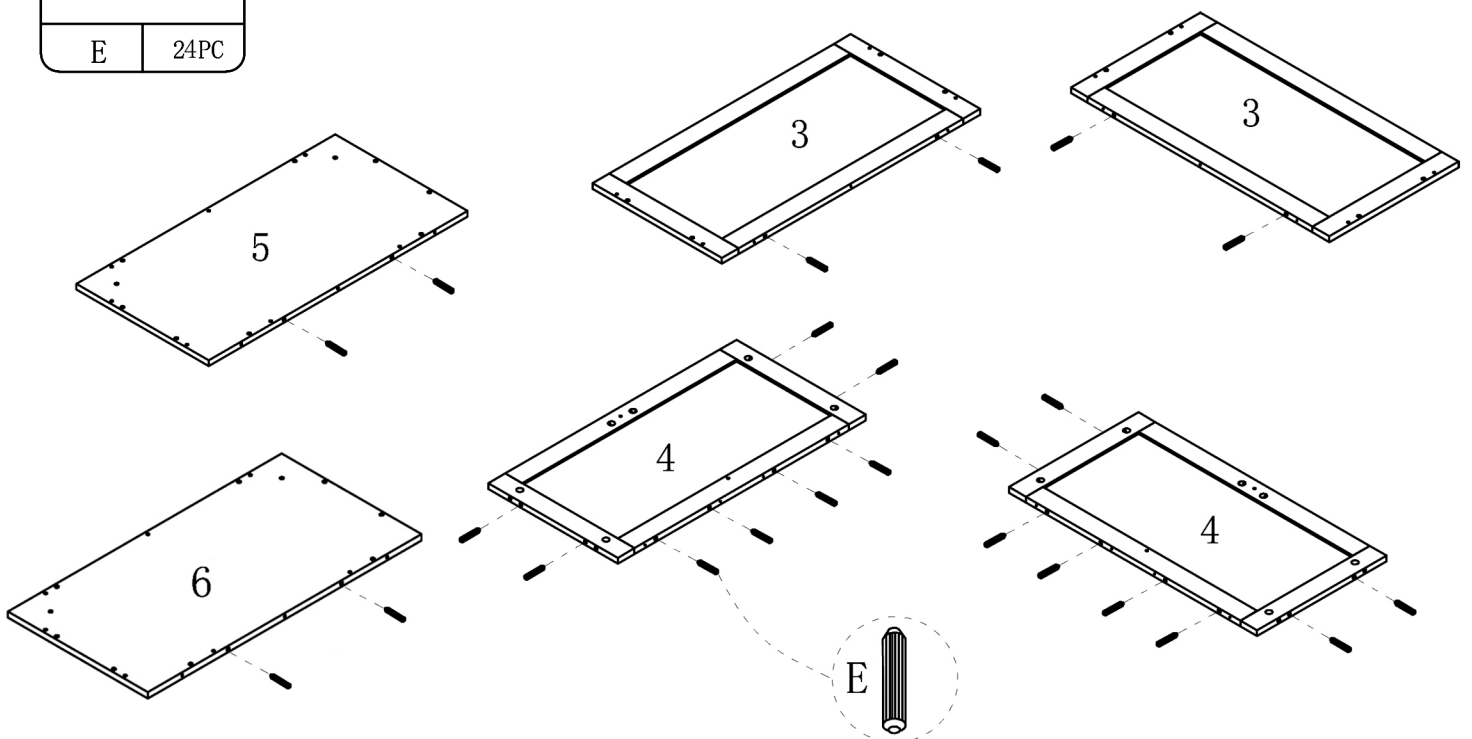

STEP 3

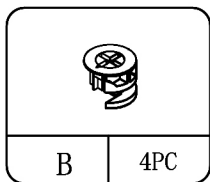

Attach Part (4) to Part (5), then insert and secure Cam Lock (B) to lock it

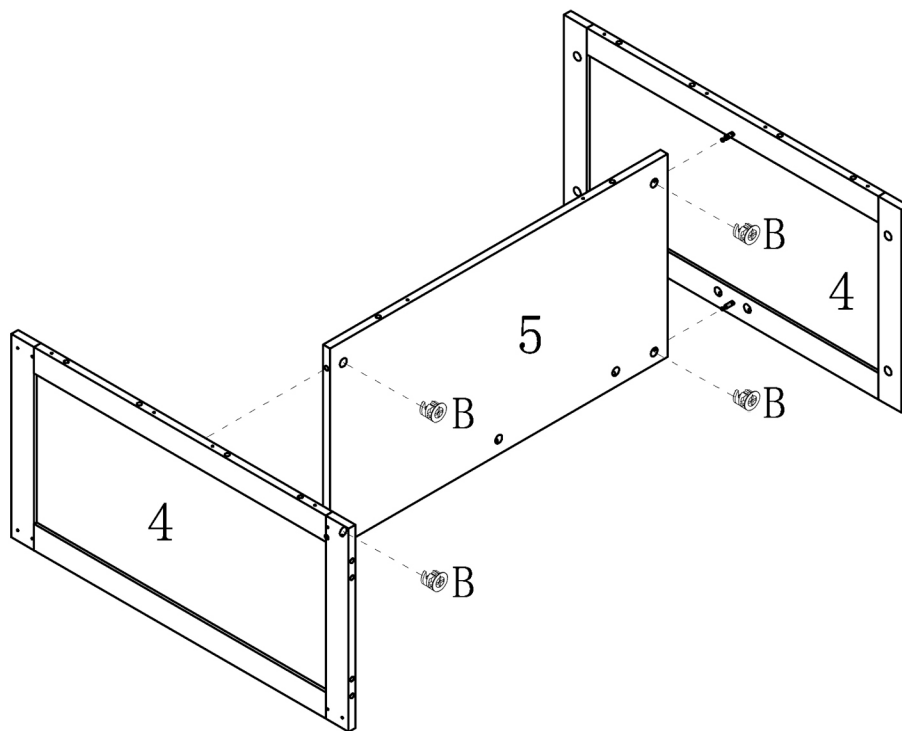

STEP 4

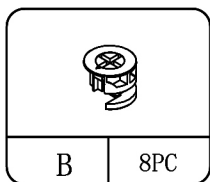

Attach Part (3) to Part (4), then insert and secure Cam Lock (B) to lock it

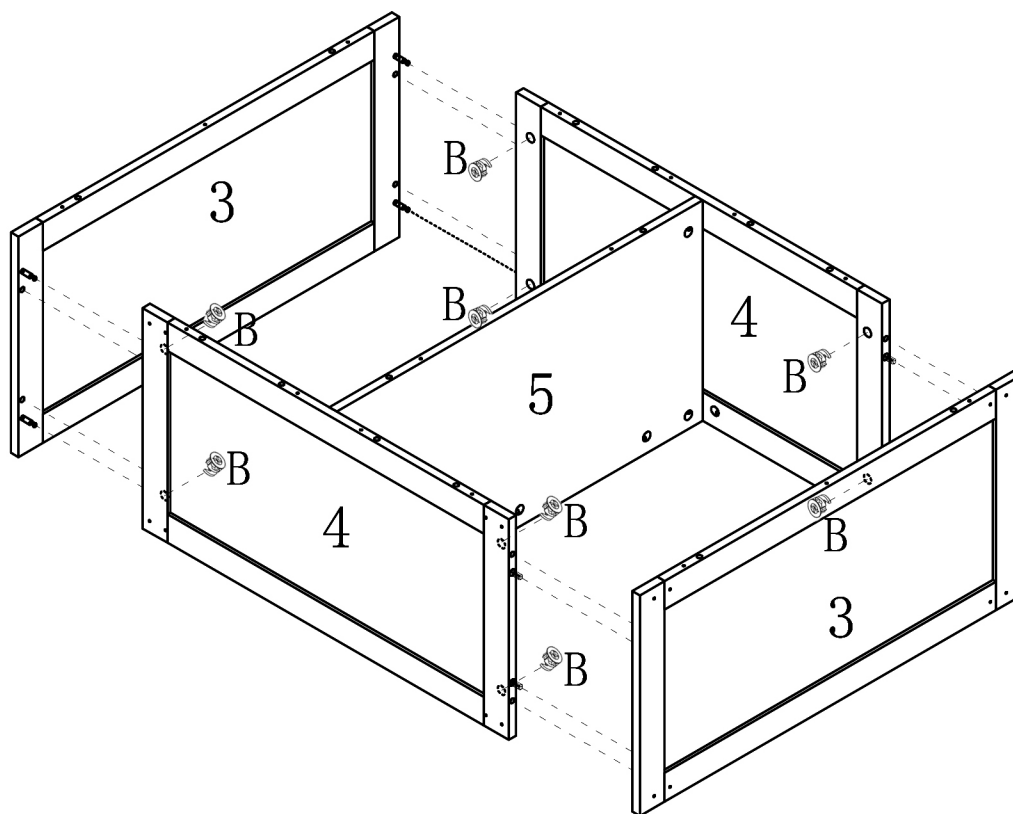

STEP 5

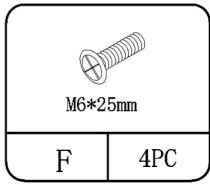

Attach Part (8) to Part (6,7) with Bolt (F) using screwdriver

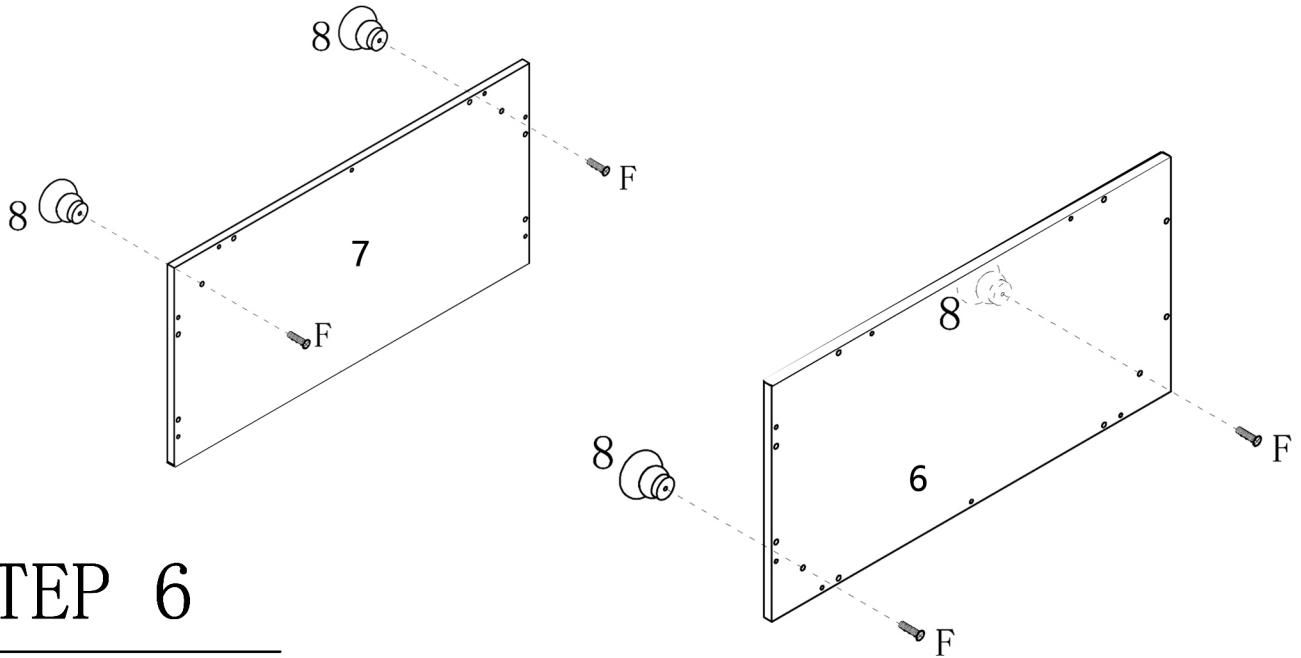

STEP 6

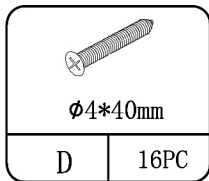

Attach Part (6) and Part (7)
Attach Part (6,7) to Part (3,4)
Insert and secure Cam Lock(B) to lock Part (6) and Part (7)
Using screwdriver for Bolt (D) to lock part (6,7) to part (3,4)

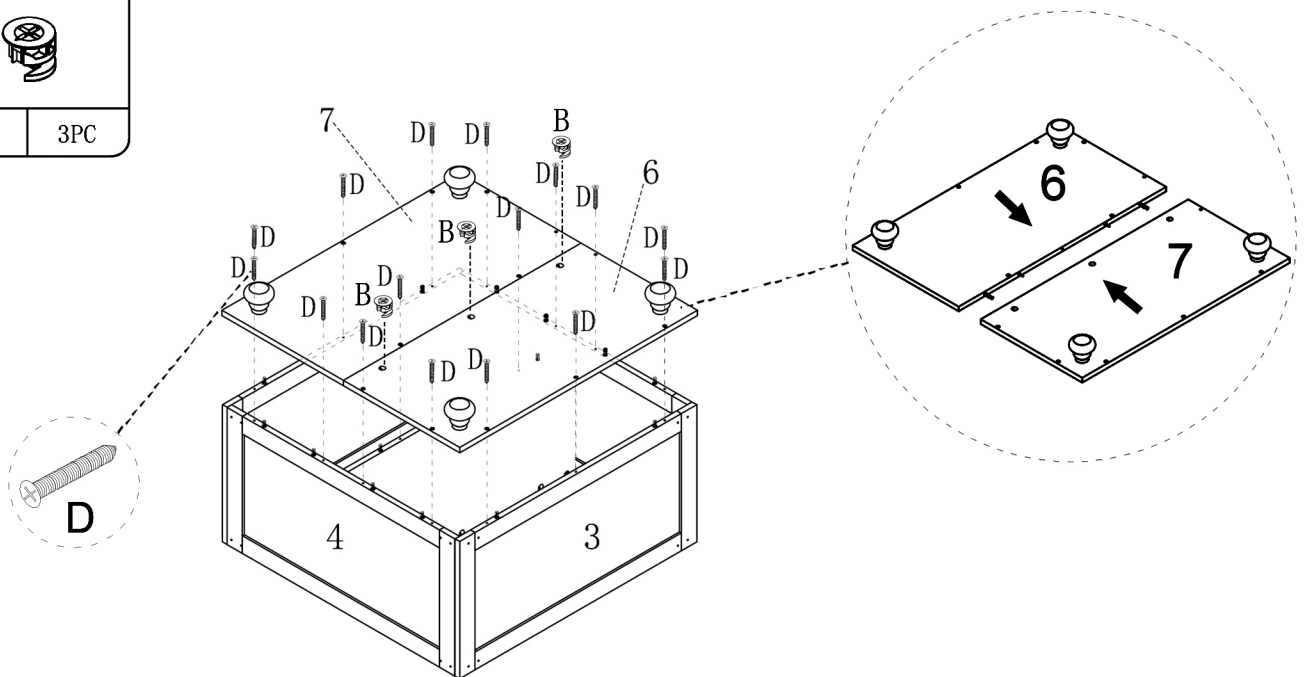
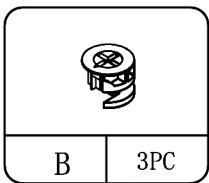

STEP 7

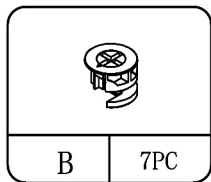

Attach Part (2) to Part (4,5), then insert and secure Cam Lock (B) to lock it

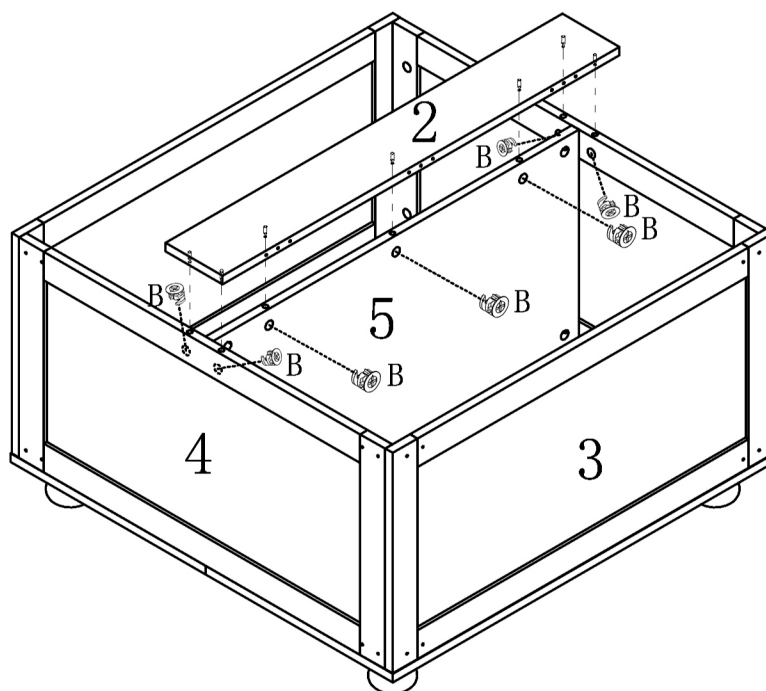

STEP 8

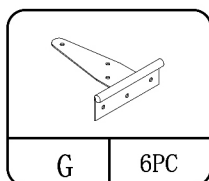
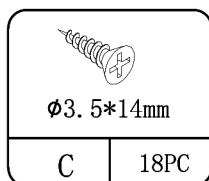

Attach hinges (G) to Part 2 with Screw (C) using screwdriver

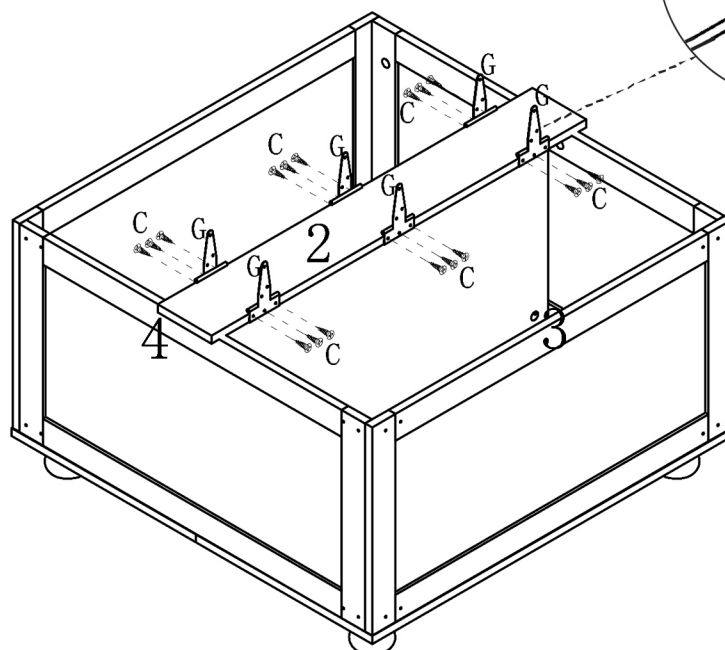
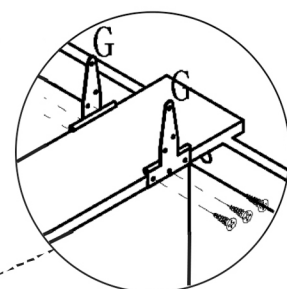

STEP 9

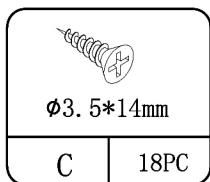

Attach hinges (G) to Part 1 with Screw (C) using screwdriver

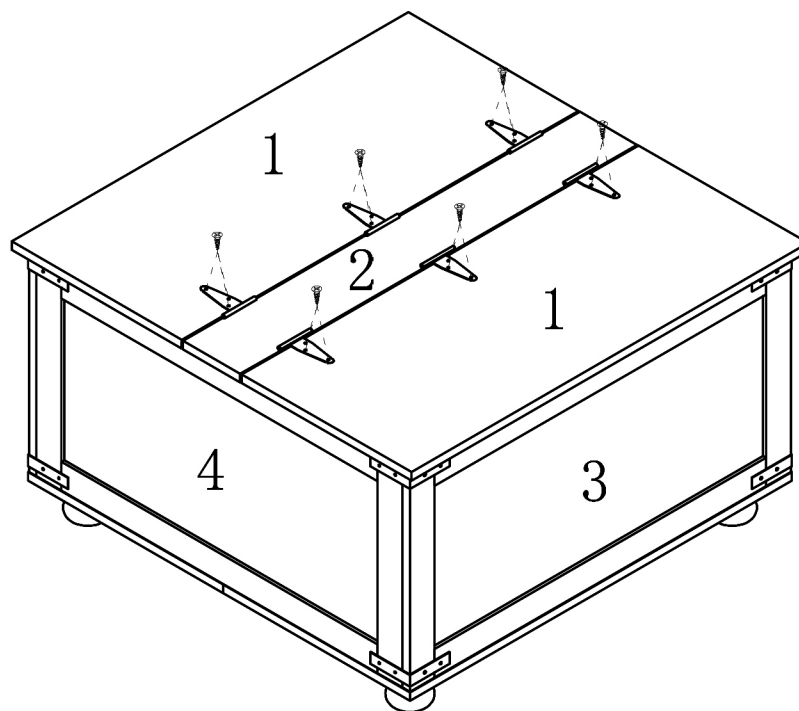

STEP 10

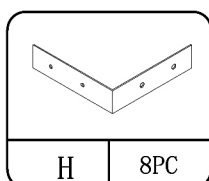
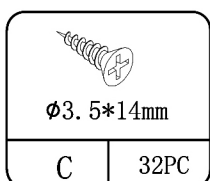

Attach Black Metal Bar to Part (3,4) with Screw (C) using screwdriver

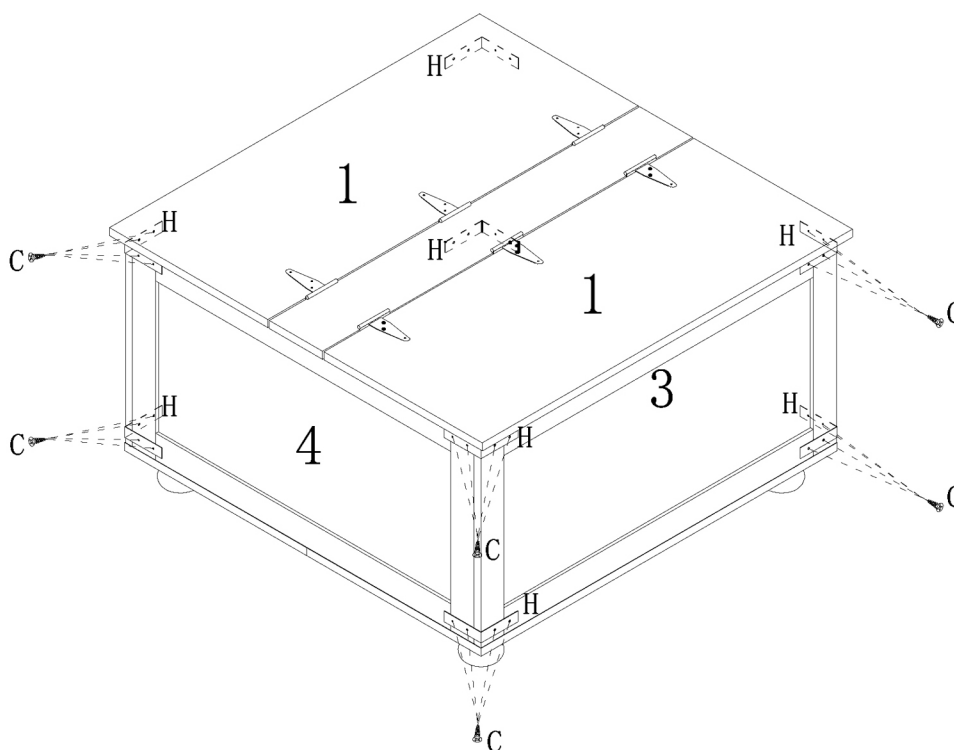

STEP 11

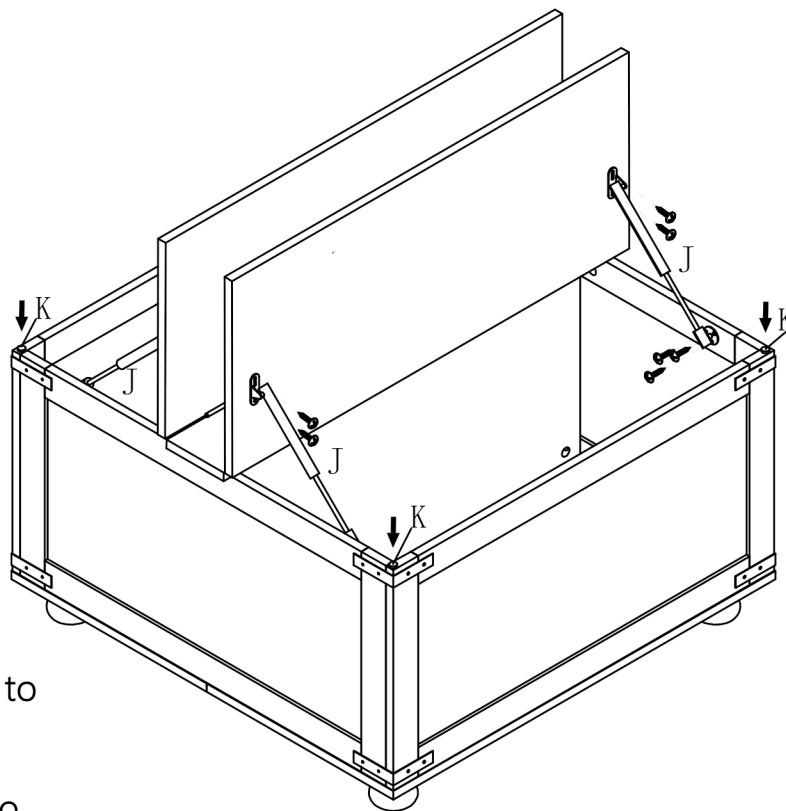
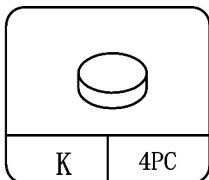
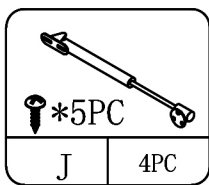

Attach Gas Shock Strut Spring (J) to Part (1,4) with Screw using screwdriver
Place the Anti-drop Mat (K) to Part(1) as per diagram

STEP 12

