







MODEL:QUEEN BED (13 PCS LVL SLATS)

Read this instruction carefully. See hardware and furniture part list for guidance. Be sure all part is complete, before you assemble. Place all wooden furniture part on a clean and flat soft surface to prevent from being scratched. Follow the figure to start assembling.









CAUTION:

1. Do not FULLY-TIGHTEN the nut or bolt untill all nut or nut bolt is ready to assembled.
2. Do not OVER-TIGHTEN the nut or nut bolt to avoid causing damages to the thread.
3. Keep all hardware part out of reach of children.

PART LIST

NO	DESCRIPTION		QTY
1	HEADBOARD		1 PC
2	FOOTBOARD		1 PC
3	SIDE RAIL		2 PCS
4	CENTER RAIL		1 PC
5	SUPPORT LEG		3 PCS
6	SLAT		13 PCS
7	BED LEG		4 PCS

HARDWARE LIST

NO	DESCRIPTION		QTY
A	JCBB M8 X 35MM		8PCS
B	JCBC M6 X 40MM		6PCS
C	SPRING WASHER 5/16"		14PCS
D	FLAT WASHER 5/16"		8PCS
E	FLAT WASHER 1/4"		6PCS
F	CSK M4 X 30MM		33PCS
G	ALLEN KEY M4		1PC
H	ALLEN KEY M5		1PC

STEP 1

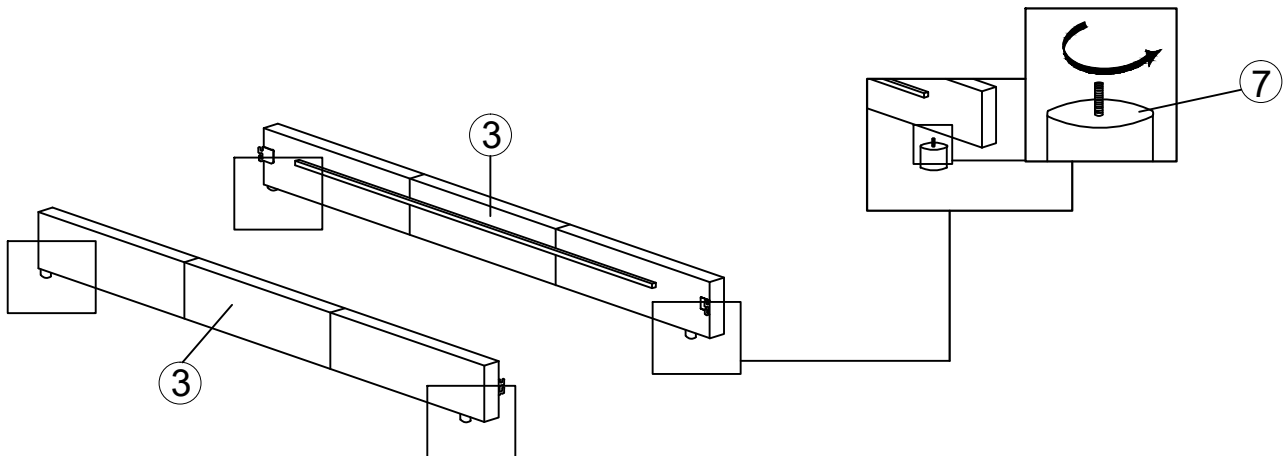

STEP 2

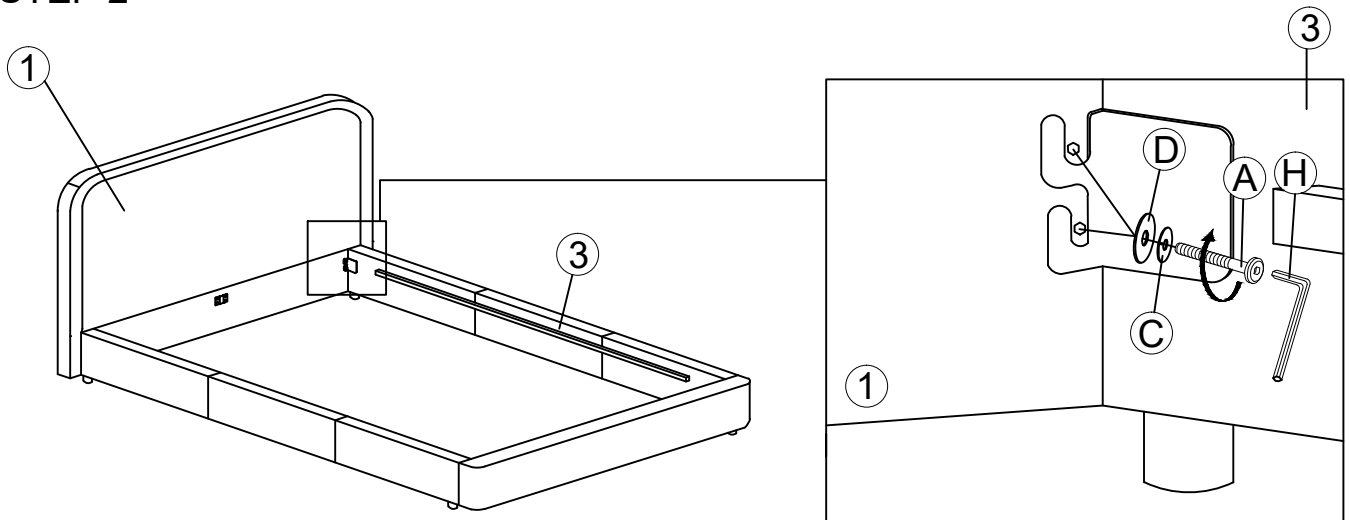

STEP 3

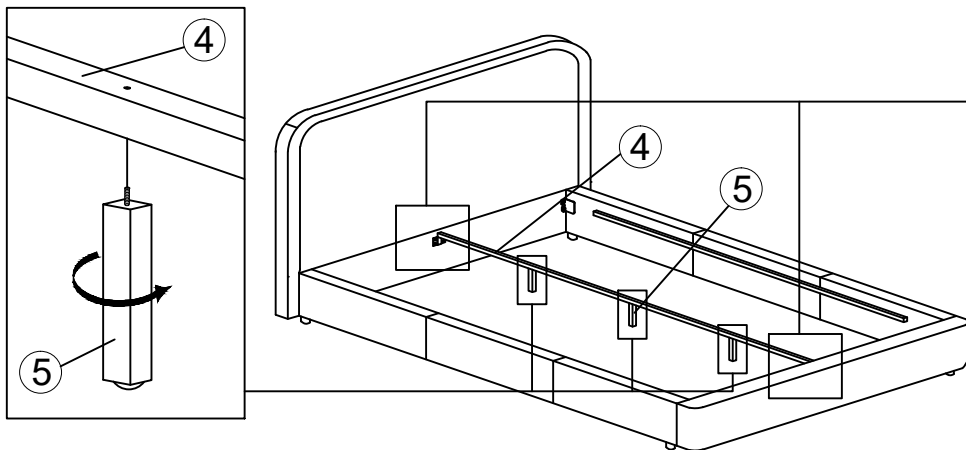

STEP 4

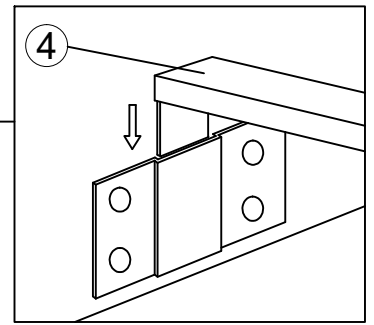

STEP 5

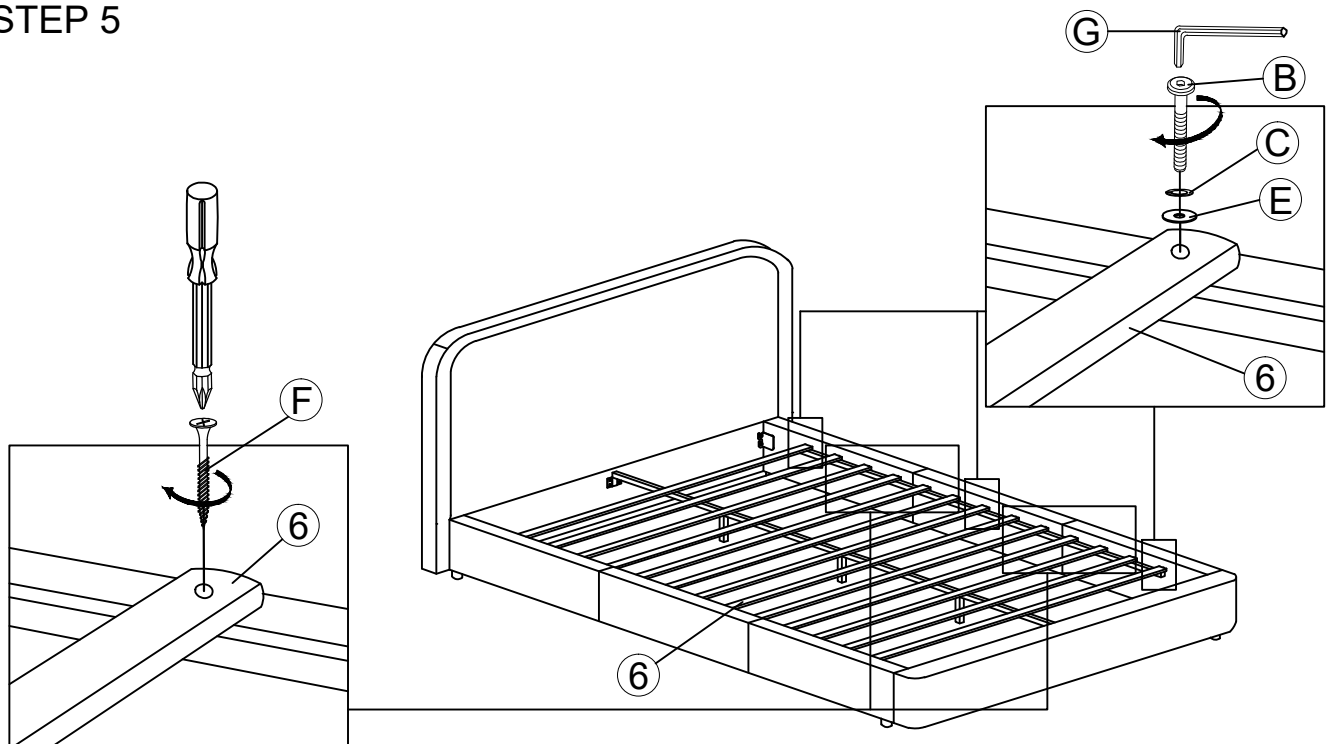

STEP 6

