

N635P389312N

N635P389313N

N635P389314N



Ú!| à~ &Á æ~ æ
Õ^à!æ &@æ, ^ã~ } * Á
T æ~ ^|Á~ Á!| à~ ãÁ
T æ~ æ^Á^|Á!| à~ &ç Á
T æ~ æ^Á^|Á!| à[ç

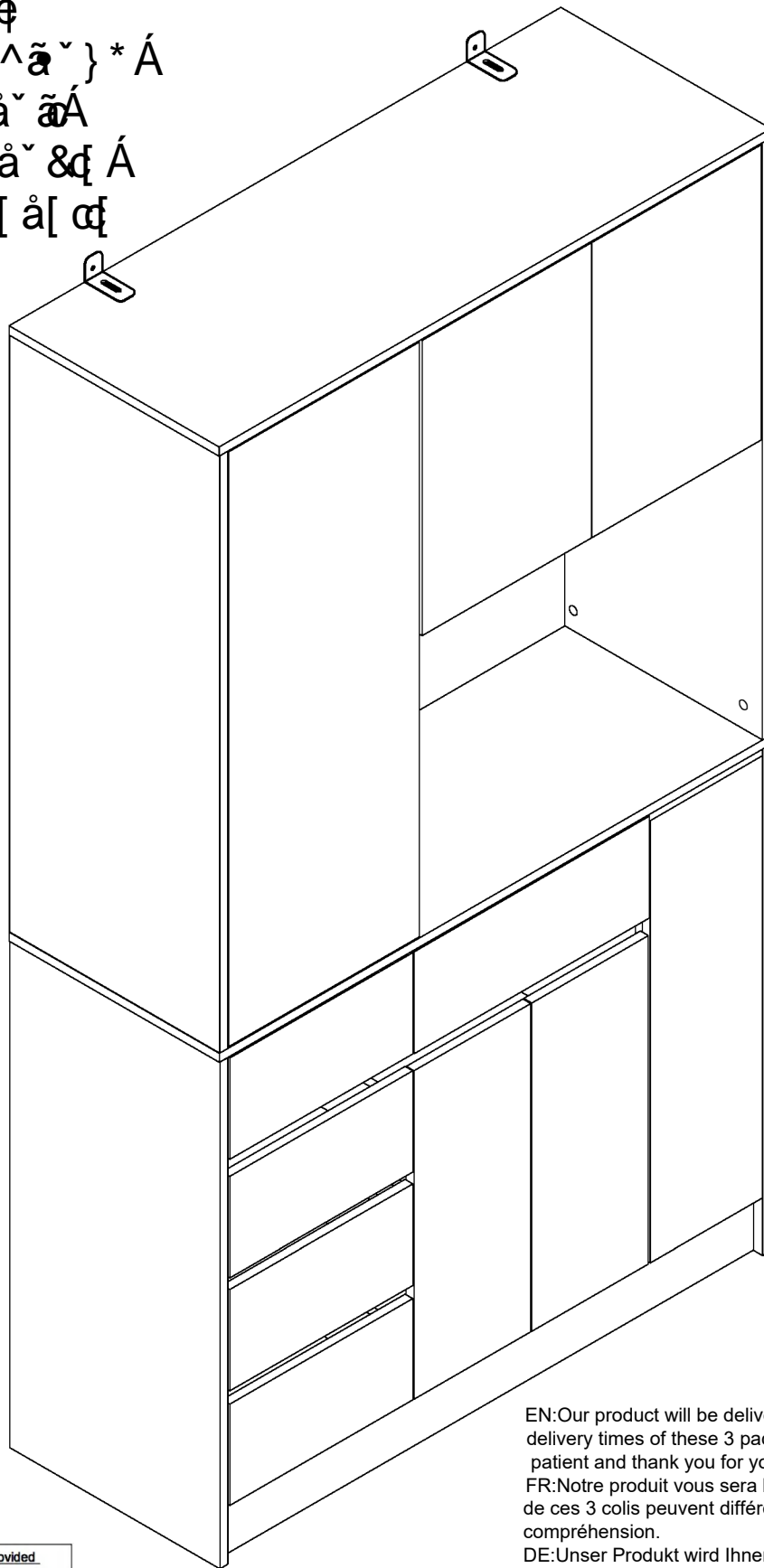

EN:Our product will be delivered to you in 3 packages. The delivery times of these 3 packages may differ, please be patient and thank you for your understanding
FR:Notre produit vous sera livré en 3 colis. Les délais de livraison de ces 3 colis peuvent différer, soyez patient et merci de votre compréhension.

DE:Unser Produkt wird Ihnen in 3 Paketen geliefert. Die Lieferzeiten dieser 3 Pakete können abweichen, bitte haben Sie etwas Geduld und vielen Dank für Ihr Verständnis

IT:I nostri prodotti vengono trasportati in 3 pacchetti. I tempi di consegna dei 3 pacchetti sono diversi:abbiate pazienza e vi ringrazio per la vostra comprensione.

ES:Nuestro producto se entrega en 3 paquetes. El tiempo de entrega de estos 3 paquetes es diferente. Por favor, sea paciente. Gracias por su comprensión.

| | | | |
|-------|--------|----------------------------|--|
| | | Tool Required Not Provided | |
| 2PERS | 45 MIN | | |

FR
Cet appareil, ses cordons, et batterie se recyclent

À DÉPOSER EN MAGASIN

OU

À DÉPOSER EN DÉCHÈTERIE

Points de collecte sur www.quefairedemesdechets.fr
Privilégiez la réparation ou le don de votre appareil !

FR
DONNEZ OU RECYCLEZ

ASSOCIATION

OU

MAGASIN

OU

DÉCHÈTERIE

FR
DONNEZ OU RECYCLEZ

ASSOCIATION

OU

MAGASIN

OU

DÉCHÈTERIE

Adresses sur quefairedemesdechets.fr



[DE]

Warnung: Lesen Sie diese Anleitung vor dem Zusammenbau bitte vollständig durch. Überprüfen Sie, ob Sie alle auf den Seiten aufgeführten Komponenten und Werkzeuge haben. Bewahren Sie die Anleitung zum späteren Nachschlagen auf. Teile des Zusammenbaus lassen sich mit 2 Personen leichter durchführen. Suchen Sie bei Bedarf professionelle Hilfe.

Warnung: Legen Sie alle Teile auf eine ebene Fläche. Legen Sie eine weiche Decke oder Ähnliches darunter, um sie vor Kratzern oder Flecken zu schützen. Vermeiden Sie es, Komponenten über den Boden zu ziehen oder zu schieben.

Warnung: Überprüfen Sie regelmäßig alle Beschläge und Befestigungen, um sicherzustellen, dass sie sicher sind und um Unfälle zu vermeiden. Wenn Teile fehlen, kaputt, beschädigt oder abgenutzt sind, verwenden Sie das Produkt nicht weiter, bis es mit vom Hersteller autorisierten Teilen repariert wurde.

Warnung: Lassen Sie Kinder nicht auf die Möbel klettern, da dies zum Umkippen und zu schweren Verletzungen führen kann. Bauen Sie die Möbel außerhalb der Reichweite von Kindern zusammen.

Warnung: Stellen Sie die Möbel nicht in die Nähe von Feuerquellen oder heißen Gegenständen, um Brandgefahr zu vermeiden.

Warnung: Reinigen Sie die Möbel mit einem feuchten Tuch oder Alkohol. Verwenden Sie keine Reinigungsmittel mit ätzenden Chemikalien.

Warnung: Dieses Produkt ist mit einer Kippschutzvorrichtung ausgestattet. Bitte installieren Sie diese Vorrichtung unbedingt, um unnötige Verletzungen durch Umkippen zu vermeiden.

[EN]

Warning: Please read these instructions fully before starting assembly. Check you have all the components and tools listed on pages. Keep the instructions for later reference. Parts of the assembly will be easier with 2 people. Seek professional assistance if necessary.

Warning: Please place all parts on a flat surface. Place a soft blanket or similar underneath to protect against scratches or stains. Avoid dragging or sliding components across the floor.

Warning: Regularly check all fittings and fastenings to ensure they are secure and to prevent accidents. If any parts are missing, broken, damaged, or worn, discontinue use of the product until repairs have been made using factory authorized parts.

Warning: Do not allow children to climb on the furniture as this may result in tipping and serious personal injury. Assemble the furniture away from the reach of children.

Warning: Do not place furniture close to fire sources or high-temperature objects to avoid the risk of fire. Do not place furniture in damp environments to prevent material damage.

Warning: Clean furniture with a damp cloth or alcohol, avoid using cleaning agents containing corrosive chemicals.

Warning: This product is equipped with an anti-tilt device. Please be sure to install this device to prevent unnecessary injuries caused by tipping.

[FR]

Avertissement : Veuillez lire attentivement ces instructions avant de commencer l'assemblage. Vérifiez que vous disposez de tous les composants et outils répertoriés sur les pages. Conservez les instructions pour référence ultérieure. Certaines parties de l'assemblage seront plus faciles à 2 personnes. Demandez l'aide d'un professionnel si nécessaire.

Avertissement : Veuillez placer toutes les pièces sur une surface plane. Placez une couverture douce ou similaire en dessous pour les protéger des rayures ou des taches. Évitez de faire glisser les composants sur le sol.

Avertissement : Vérifiez régulièrement tous les raccords et fixations pour vous assurer qu'ils sont bien fixés et pour éviter les accidents. Si des pièces manquent, sont cassées, endommagées ou usées, cessez d'utiliser le produit jusqu'à ce que des réparations aient été effectuées à l'aide de pièces autorisées par l'usine.

Avertissement : Ne laissez pas les enfants grimper sur les meubles car cela pourrait entraîner un basculement et des blessures graves. Assemblez les meubles hors de portée des enfants.

Avertissement : Ne placez pas les meubles à proximité de sources de feu ou d'objets à haute température pour éviter tout risque d'incendie.

Avertissement : Nettoyez les meubles avec un chiffon humide ou de l'alcool, évitez d'utiliser des produits de nettoyage contenant des produits chimiques corrosifs.

Avertissement : Ce produit est équipé d'un dispositif anti-basculement. Assurez-vous d'installer ce dispositif pour éviter les blessures inutiles causées par un basculement.

[IT]

Attenzione: leggere attentamente queste istruzioni prima di iniziare il montaggio. Verificare di avere tutti i componenti e gli strumenti elencati nelle pagine. Conservare le istruzioni per riferimento futuro. Alcune parti del montaggio saranno più facili con 2 persone. Se necessario, chiedere assistenza professionale.

Attenzione: posizionare tutte le parti su una superficie piana. Posizionare una coperta morbida o simile sotto per proteggere da graffi o macchie. Evitare di trascinare o far scivolare i componenti sul pavimento.

Attenzione: controllare regolarmente tutti i raccordi e i dispositivi di fissaggio per assicurarsi che siano sicuri e per prevenire incidenti. Se alcune parti sono mancanti, rotte, danneggiate o usurate, interrompere l'uso del prodotto fino a quando non siano state eseguite le riparazioni utilizzando parti autorizzate dalla fabbrica.

Attenzione: non consentire ai bambini di arrampicarsi sui mobili poiché ciò potrebbe causare ribaltamenti e gravi lesioni personali. Montare i mobili lontano dalla portata dei bambini.

Attenzione: non posizionare i mobili vicino a fonti di fuoco o oggetti ad alta temperatura per evitare il rischio di incendio

Attenzione: pulire i mobili con un panno umido o alcol, evitare di utilizzare detergenti contenenti sostanze chimiche corrosive.

Attenzione: questo prodotto è dotato di un dispositivo antiribaltamento. Assicurarsi di installare questo dispositivo per prevenire lesioni inutili causate dal ribaltamento.

[ES]

Advertencia: Lea estas instrucciones completamente antes de comenzar el montaje. Compruebe que tiene todos los componentes y herramientas que se enumeran en las páginas. Conserve las instrucciones para consultarlas más adelante. El montaje de algunas partes será más sencillo con 2 personas. Busque ayuda profesional si es necesario.

Advertencia: Coloque todas las piezas sobre una superficie plana. Coloque una manta suave o algo similar debajo para protegerlas de rayones o manchas. Evite arrastrar o deslizar los componentes por el piso.

Advertencia: Verifique regularmente todos los accesorios y fijaciones para asegurarse de que estén seguros y evitar accidentes. Si falta alguna pieza, está rota, dañada o desgastada, deje de usar el producto hasta que se hayan realizado las reparaciones con piezas autorizadas de fábrica.

Advertencia: No permita que los niños se suban a los muebles, ya que esto puede provocar que se vuelquen y lesiones personales graves. Monte los muebles fuera del alcance de los niños.

Advertencia: No coloque los muebles cerca de fuentes de fuego u objetos de alta temperatura para evitar el riesgo de incendio.

Advertencia: Limpie los muebles con un paño húmedo o alcohol, evite usar agentes de limpieza que contengan químicos corrosivos.

Advertencia: Este producto está equipado con un dispositivo antivuelco. Asegúrese de instalar este dispositivo para evitar lesiones innecesarias causadas por vuelcos.

| | |
|---|--|
| Importeur | Decobus Handel GmbH |
| Adresse | Innungsstraße 9, 21244 Buchholz, Deutschland |
| URL | https://www.decobusgroup.de |
| Hersteller | Shouguang May Home Furniture Co., Ltd. |
| Adresse | Shouguang City, Weifang City, Shandong Province, China |
| Email/URL | http://www.himayhome.com |
| Partienummer | N635P389312N, N635P389313N, N635P389314N |
| Hergestellt in | CHINA |
|  | Decobus Handel GmbH Innungsstraße 9, 21244 Buchholz, Deutschland https://www.decobusgroup.de |

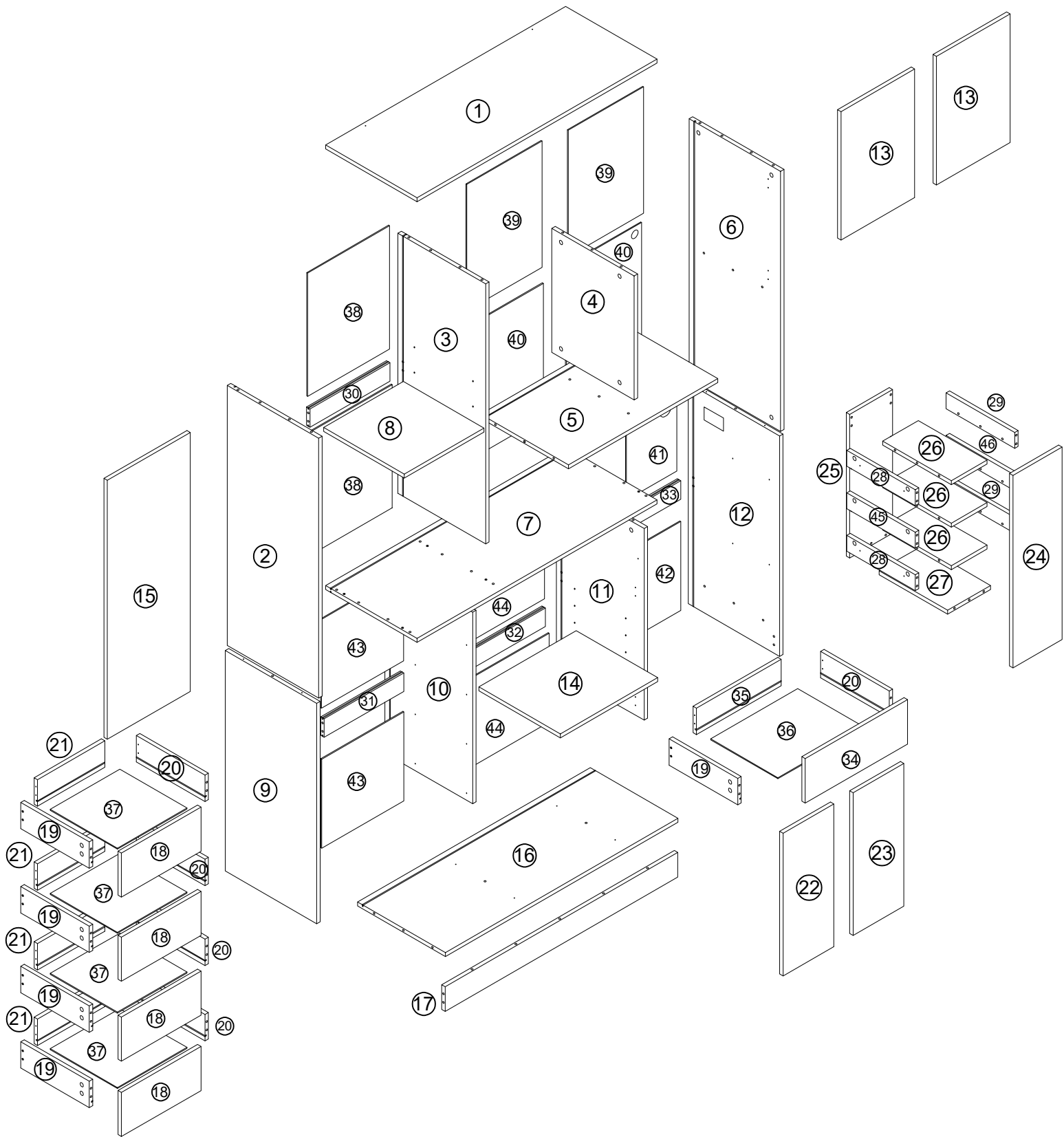

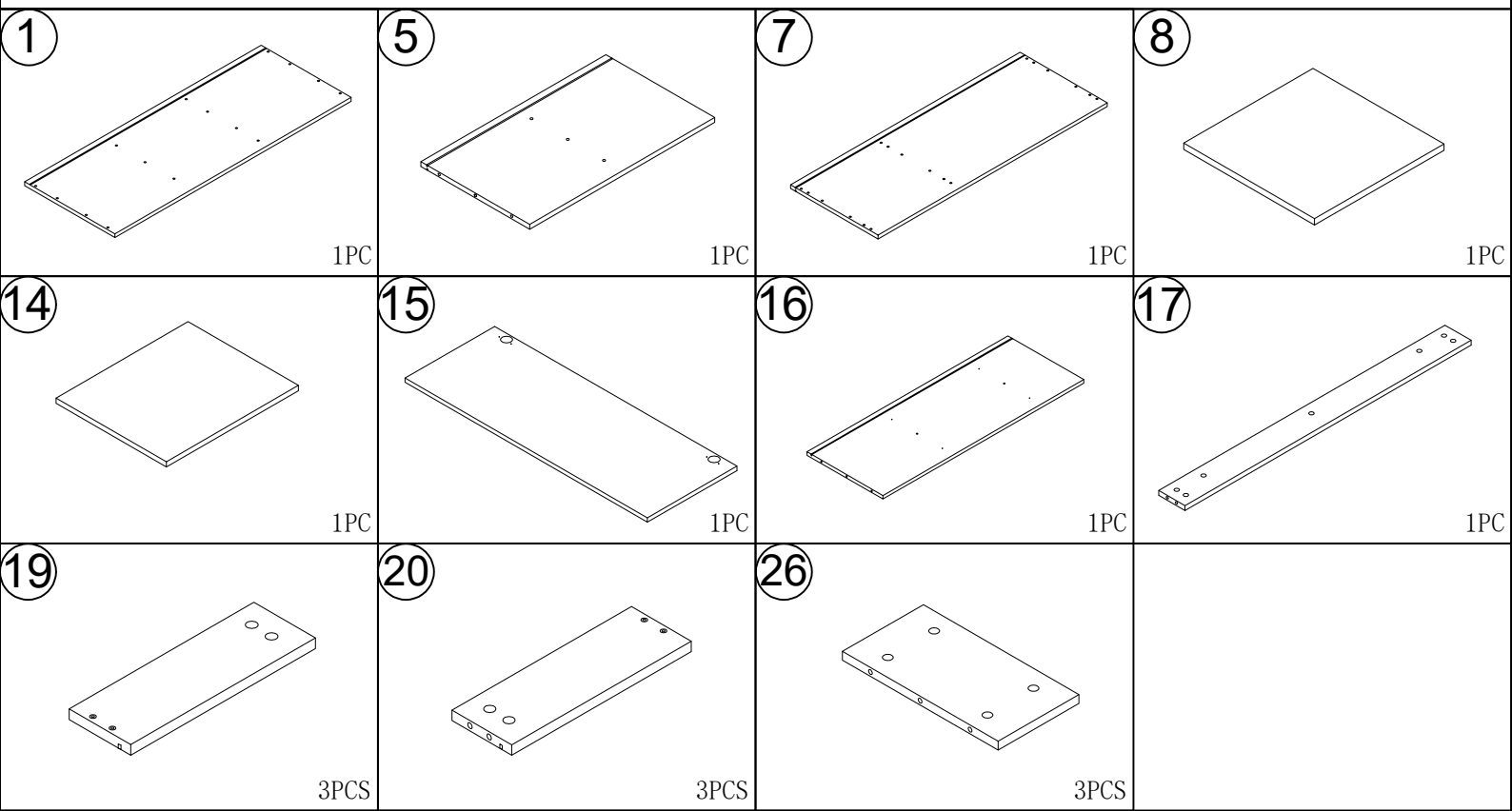

N635P389312N

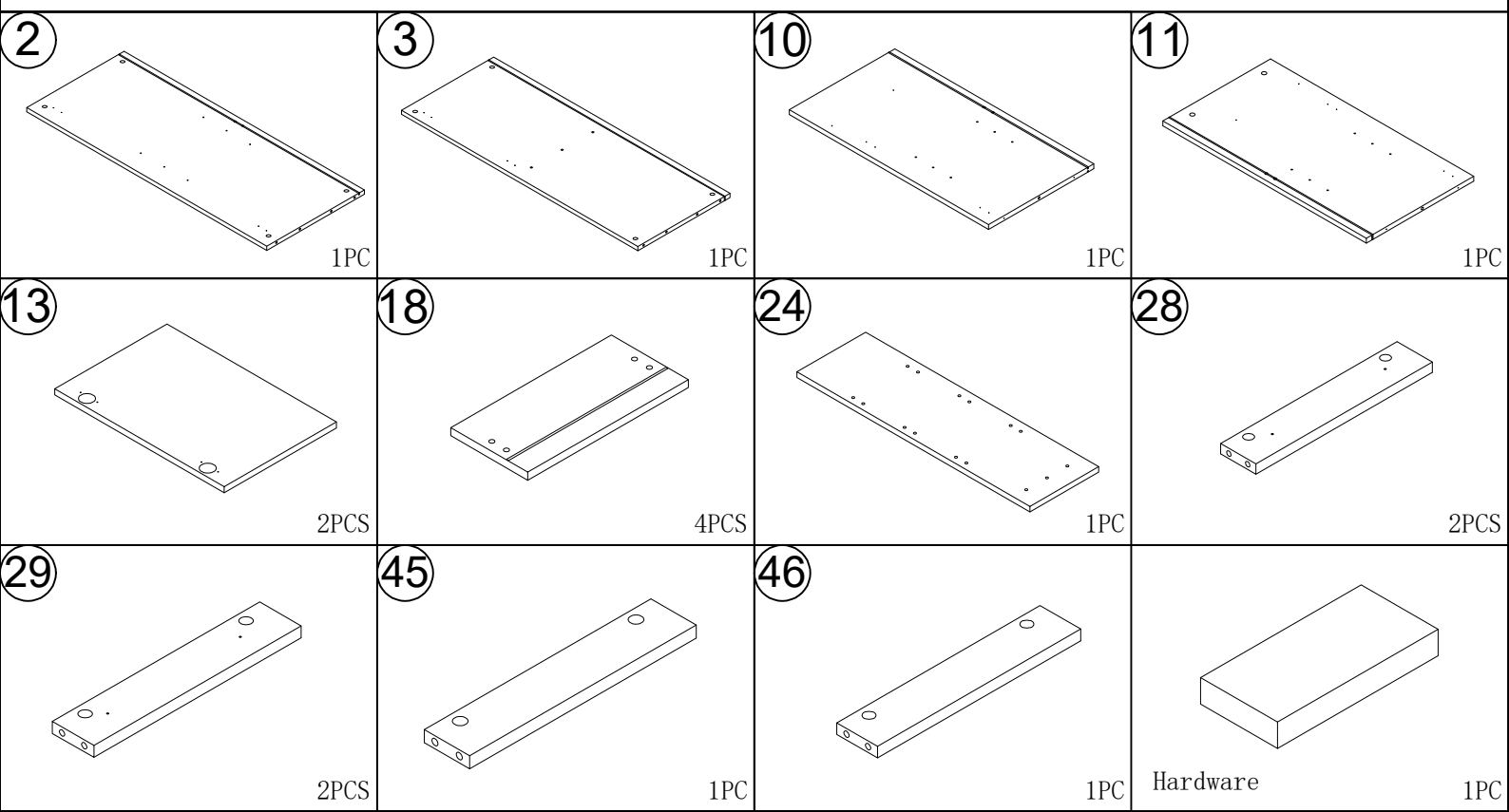

N635P389313N

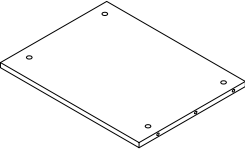
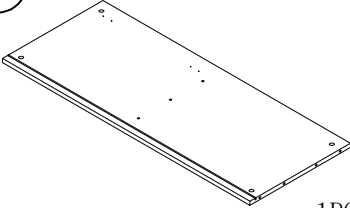
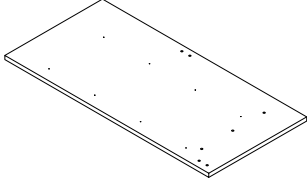
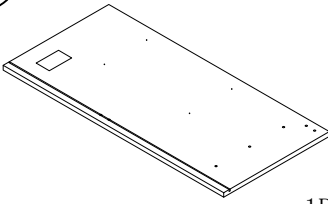
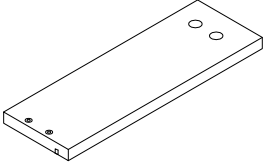
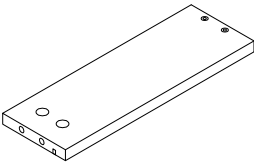
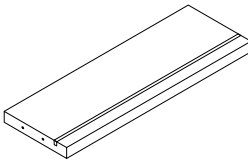
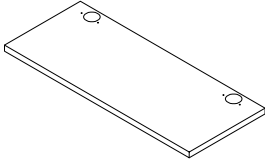
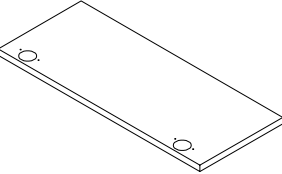
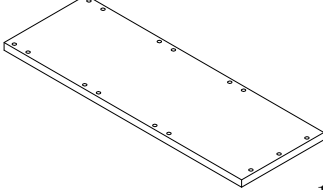
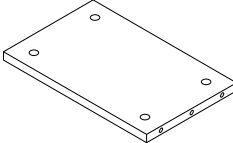
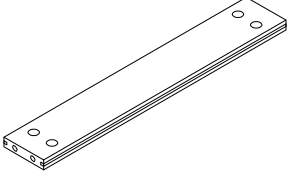
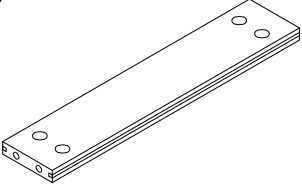
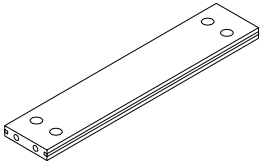
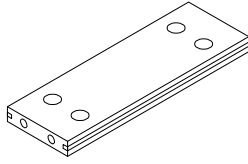
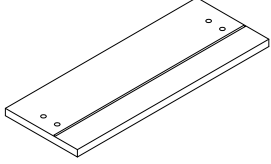
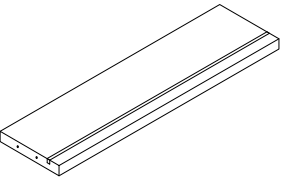
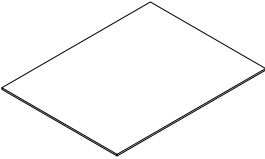
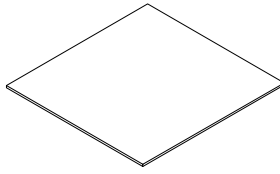
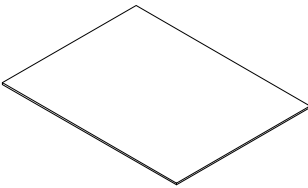
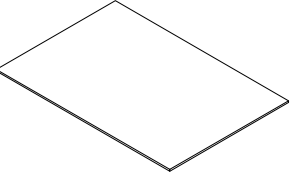
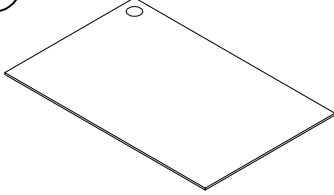
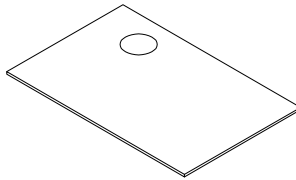
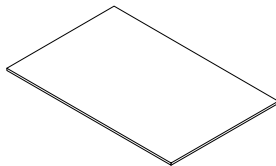
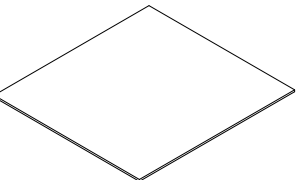
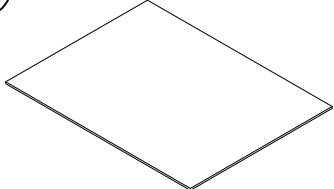
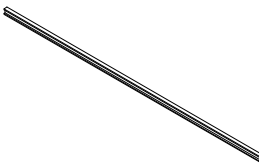

N635P389314N

| | | | |
|--|---|--|---|
|  <p>4</p> <p>1PC</p> |  <p>6</p> <p>1PC</p> |  <p>9</p> <p>1PC</p> |  <p>12</p> <p>1PC</p> |
|  <p>19</p> <p>2PCS</p> |  <p>20</p> <p>2PCS</p> |  <p>21</p> <p>4PCS</p> |  <p>22</p> <p>1PC</p> |
|  <p>23</p> <p>1PC</p> |  <p>25</p> <p>1PC</p> |  <p>27</p> <p>1PC</p> |  <p>30</p> <p>1PC</p> |
|  <p>31</p> <p>1PC</p> |  <p>32</p> <p>1PC</p> |  <p>33</p> <p>1PC</p> |  <p>34</p> <p>1PC</p> |
|  <p>35</p> <p>1PC</p> |  <p>36</p> <p>1PC</p> |  <p>37</p> <p>4PCS</p> |  <p>38</p> <p>2PCS</p> |
|  <p>39</p> <p>2PCS</p> |  <p>40</p> <p>2PCS</p> |  <p>41</p> <p>1PC</p> |  <p>42</p> <p>1PC</p> |
|  <p>43</p> <p>2PCS</p> |  <p>44</p> <p>2PCS</p> |  <p>498MM</p> <p>Backboard strip1</p> <p>1PC</p> |  <p>468MM</p> <p>Backboard strip2</p> <p>1PC</p> |

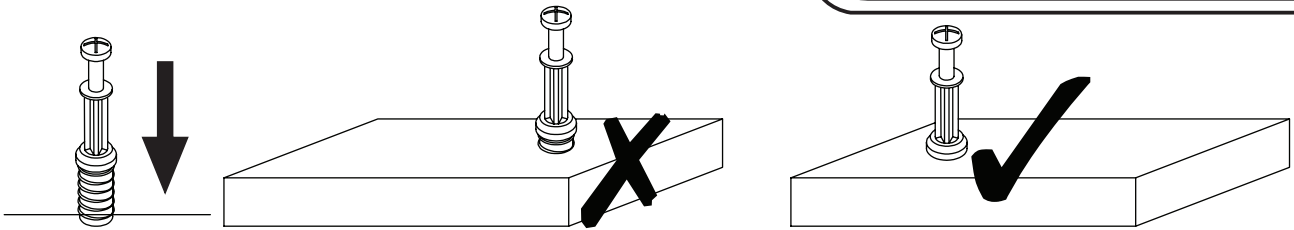

EN_QUICKFIT: Tighten quickfit until shoulder is flush with panel. Do not overtighten or undertighten.

FR_RACCORD RAPIDE: Faites serrer le raccord rapide jusqu'à ce que l'épaulement soit parfaitement encastré dans le panneau. Il ne faut ni trop serrer ni insuffisamment serrer.

ES_QUICKFIT: Apriete quickfit hasta que el hombro se descargue con el panel. NO lo sobreapriete ni lo apriete poco.

DE_QUICKFIT: Ziehen Sie den Quickfit fest, bis die Schulter mit der Platte bündig ist. Bitte nicht zu fest oder zu schwach anziehen.

IT_MONTAGGIO RAPIDO: Stringere il montaggio rapido fino a quando la spalla è a filo con il pannello, non stringere troppo o troppo poco.

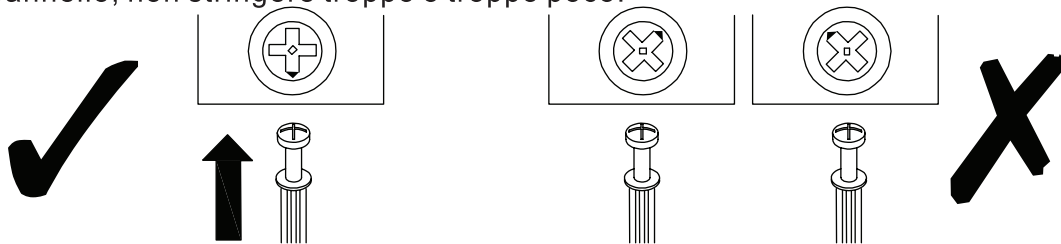

EN_CAM LOCK: When fitting cam lock, ensure starting position is correct before you insert connecting quickfit.

FR_SERRURE BATTEUSE: Avant d'insérer la serrure batteuse, veillez à la bonne orientation avant d'insérer le raccord rapide.

ES_CIERRE DE LA CÁMARA: Cuando instale el cierre de la cámara, asegúrese de que la posición de inicio es correcta antes de que inserte el quickfit conector.

DE_CAM-LOCK: Achten Sie bei der Montage des Cam-Locks auf die richtige Ausgangsposition, bevor Sie den Quickfit einsetzen.

IT_BLOCCAGGIO A CAMMA: Quando si monta il bloccaggio a camma, assicurarsi che la posizione iniziale sia corretta prima di inserire il montaggio rapido di collegamento.

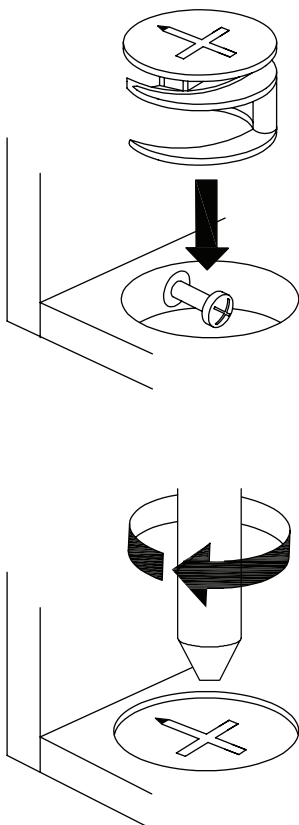

EN_Quickfit head should be in the centre of the cam lock when the two panels are joined.

Cam lock should be inserted before quickfit.

FR_Lorsque les deux panneaux sont assemblés, la tête du raccord rapide doit reposer au centre de la serrure batteuse. Il faut insérer la serrure batteuse avant le raccord rapide.

ES_El cabezal del quickfit debe estar en el centro del cierre de la cámara cuando se unan los dos paneles.

Se debe insertar el cierre de la cámara antes que el quickfit.

DE_Der Quickfit-Kopf sollte sich in der Mitte des Cam-Locks befinden, wenn die beiden Platten zusammengefügt sind. Der Cam-Lock sollte vor dem Quickfit eingesetzt werden.

IT_La testa del montaggio rapido deve trovarsi al centro del bloccaggio a camma quando i due pannelli sono uniti. Il Bloccaggio a Camma deve essere inserito prima del montaggio rapido.

EN_Turn cam lock clockwise to tighten.

FR_Faites tourner la serrure batteuse dans le sens des aiguilles d'une montre pour la resserrer.

ES_Gire el cierre de la cámara en sentido horario para apretarlo.

DE_Drehen Sie den Cam-Lock im Uhrzeigersinn, um ihn festzuziehen.

IT_Ruotare il bloccaggio a camma in senso orario per stringere.

EN It may be necessary to adjust the hinges so that the doors align. Use the instructions below as a guide.

FR Il est parfois nécessaire d'ajuster les charnières pour un meilleur alignement des portes. Servez-vous des instructions ci-dessous comme guide.

ES Puede que sea necesario ajustar los quicios de forma que se alineen las puertas. Use las instrucciones que aparecen debajo como guía.

DE Möglicherweise müssen Sie die Scharniere so einstellen, dass die Türen ausgerichtet sind. Verwenden Sie die nachstehenden Anweisungen als Leitfaden.

IT Potrebbe essere necessario regolare le cerniere in modo che le porte siano allineate. Per fare ciò attenersi alle istruzioni sottostanti.

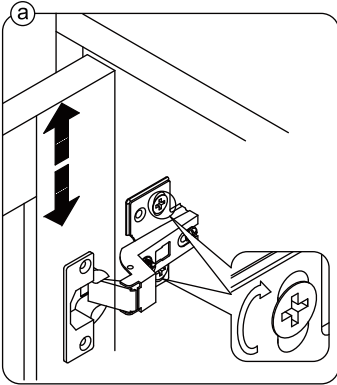

EN To adjust the door vertically loosen the screw as shown and move up and down as needed.

FR Si vous souhaitez régler la porte **verticalement**, desserrez la vis comme indiqué et déplacez la porte de haut en bas selon les besoins.

ES Para ajustar la puerta **verticalmente** afloje el tornillo tal y como se muestra y muévelo hacia arriba o hacia abajo según sea necesario.

DE Um die Tür **vertikal** auszurichten, lösen Sie die Schraube wie abgebildet und bewegen Sie sie nach Bedarf nach oben oder nach unten.

IT Per allineare la porta **verticalmente** allentare la vite come mostrato e spostarla in alto o in basso secondo necessità.

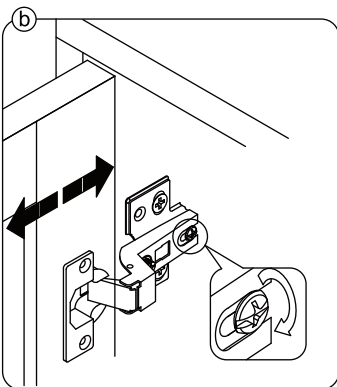

EN To adjust the gap from the door to the main frame turn the screw clockwise or anti-clockwise as needed.

FR Si vous souhaitez ajuster l'**écart** entre la porte et le cadre principal, tournez la vis dans le sens des aiguilles d'une montre ou dans le sens inverse, si nécessaire.

ES Para ajustar el **espacio** desde la puerta al marco principal, gire el tornillo en sentido horario o antihorario, según se necesite.

DE Um den **Abstand** von der Tür zum Hauptrahmen auszurichten, drehen Sie die Schraube je nach Bedarf im oder gegen den Uhrzeigersinn.

IT Per regolare lo **spazio** tra la porta e il telaio principale, avvitare o svitare la vite secondo necessità.

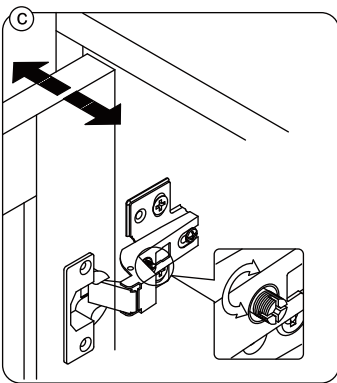

EN To adjust the door laterally adjust the screw as shown by turning clockwise or anti-clockwise.

FR Si vous souhaitez ajuster la porte **latéralement**, ajustez la vis comme indiqué en tournant dans le sens des aiguilles d'une montre ou dans le sens inverse des aiguilles d'une montre.

ES Para ajustar la puerta **lateralmente** ajuste el tornillo tal y como se muestra girándolo en sentido horario y antihorario.

DE Um die Tür **seitlich** auszurichten, stellen Sie bitte die Schraube wie abgebildet durch Drehen im oder gegen den Uhrzeigersinn ein.

IT Per allineare la porta **lateralmente** regolare la vite come mostrato, avvitarandola o svitarandola.

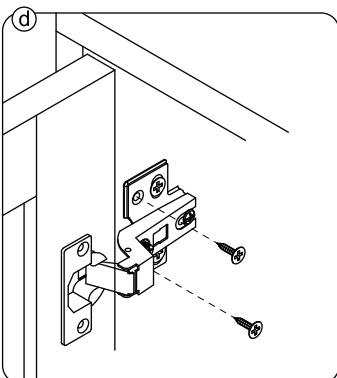

EN Please fix other screws

FR Merci de serrer les autres vis.

ES Fije los demás tornillos

DE Befestigen Sie bitte die anderen Schrauben

IT Fissare le altre viti

EN_NOTE: Pull inner and outer drawer runners apart before fixing them to panels.

FR_REMARQUE: Avant de fixer les glissières de tiroir aux panneaux, tirez vers l'extérieur et poussez vers l'intérieur de chacun des tiroirs.

ES_NOTA: retire los rieles interiores y exteriores antes de fijarlos a los paneles.

PT_NOTA: Separar as corredeças das gavetas interiores e exteriores antes de fixar para os painéis.

DE_HINWEIS: Ziehen Sie die inneren und äußeren Schubladenführung auseinander, bevor Sie sie an den Platten befestigen.

IT_NOTA: Separare le guide interne ed esterne del cassetto prima di fissarle ai pannelli.

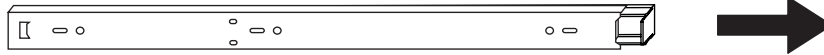

EN_Slide drawer runners apart until the drawer lock can be seen, as shown.

FR_Les glissières de tiroir doivent être ouvertes jusqu'à ce que la serrure du tiroir soit visible, comme indiqué.

ES_Deslice a un lado los rieles del cajón hasta que se pueda ver el cierre del armario, tal y como se muestra.

PT_Deslizam-se as gavetas até se poder ver o fecho da gaveta, como se mostra.

DE_Schieben Sie die Schubladenführungen auseinander, bis das Schubladenschloss sichtbar ist, gemäß der Abbildung.

IT_Far scorrere le guide del cassetto fino a quando non sia visibile il blocco di scorrimento, come mostrato.

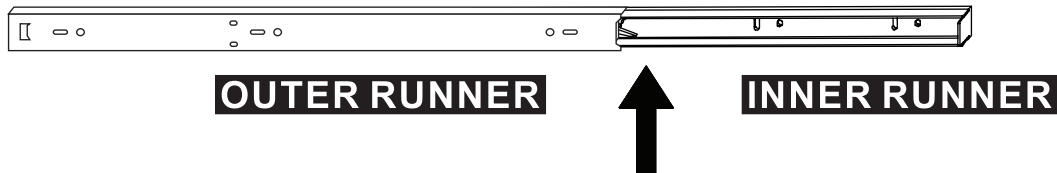

EN_Press and hold the drawer runner lock and then continue to slide drawer runners apart, as shown.

FR_En appuyant et en maintenant le verrouillage des glissières de tiroir, vous pouvez continuer à les écarter l'une de l'autre, comme indiqué.

ES_Mantenga presionado el cierre del riel del cajón y después continúe deslizando a un lado los rieles de los cajones, tal y como se muestra.

PT_Manter pressionado o fecho de gaveta e depois continuar a deslizar as corredeças da gaveta, como mostrado.

DE_Drücken und halten Sie die Verriegelung der Schubladenführung und schieben Sie die Schubladenführungen wie abgebildet weiter auseinander.

IT_Tenere premuto il blocco di scorrimento e quindi continuare a far scorrere la guida, come mostrato.

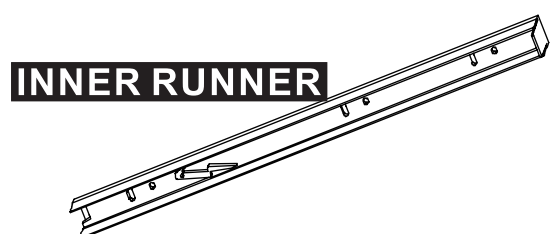
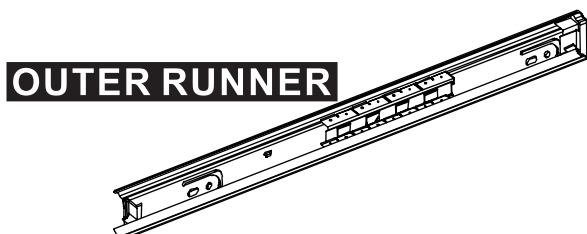
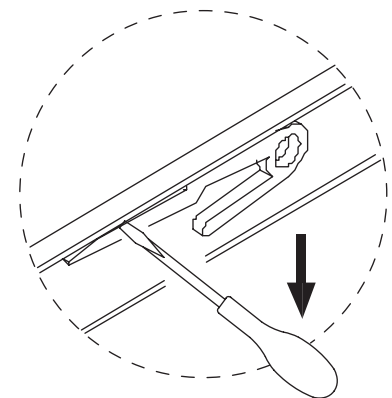

EN_Your inner and outer drawer runners are ready to be fixed to panels.





FR_Il est possible, à présent, de fixer les glissières intérieures et extérieures de vos tiroirs sur des panneaux.

ES_Los rieles interiores y exteriores del cajón están listos para fijarse a los paneles.

PT_As corredeças das gavetas interiores e exteriores estão prontas para serem fixadas nos painéis.

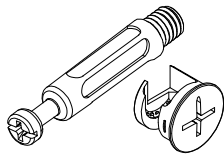
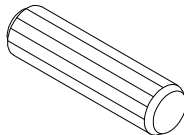
DE_Ihre inneren und äußeren Schubladenführungen sind bereit, an den Platten befestigt zu werden.

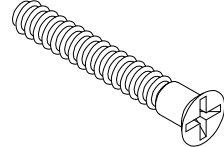
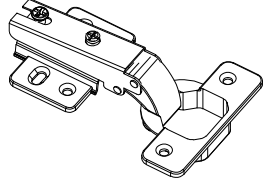
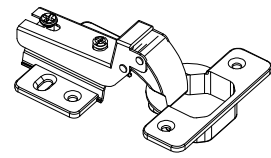
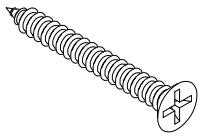
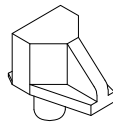
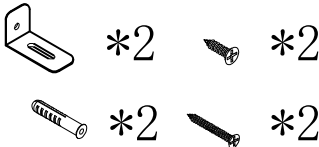
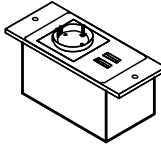
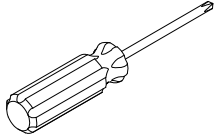
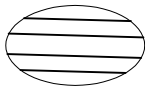
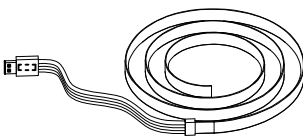
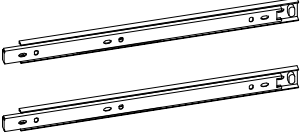
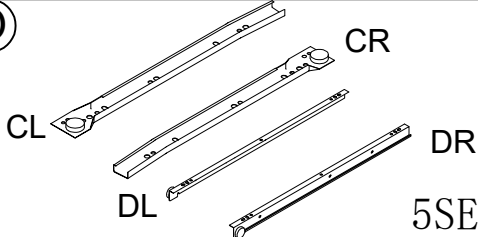
IT_Le guide interne ed esterne sono pronte per essere fissate ai pannelli.

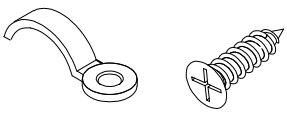
| | |
|---|--|
| <p>(A)</p>  <p>97SETS</p> | <p>(B)</p>  <p>ø8*30 46PCS</p> |
| <p>(C)</p>  <p>ø3.5*14 128PCS</p> | <p>(D)</p>  <p>ø5*40 10PCS</p> |
| <p>(E)</p>  <p>4PCS</p> | <p>(F)</p>  <p>6PCS</p> |
| <p>(G)</p>  <p>ø3.5*35 20PCS</p> | <p>(H)</p>  <p>8PCS</p> |
| <p>(I)</p>  <p>*2 *2 *2 *2 1SET</p> | <p>(J)</p>  <p>1PC</p> |
| <p>(K)</p>  <p>1PC</p> | <p>(L)</p>  <p>30PCS</p> |
| <p>(M)</p>  <p>1PC</p> | <p>(N)</p>  <p>2SETS</p> |
| <p>(O)</p>  <p>CL CR DL DR 5SETS</p> | <p>(P)</p>  <p>30PCS</p> |
| <p>(Q)</p>  <p>ø3*14 4PCS</p> | |

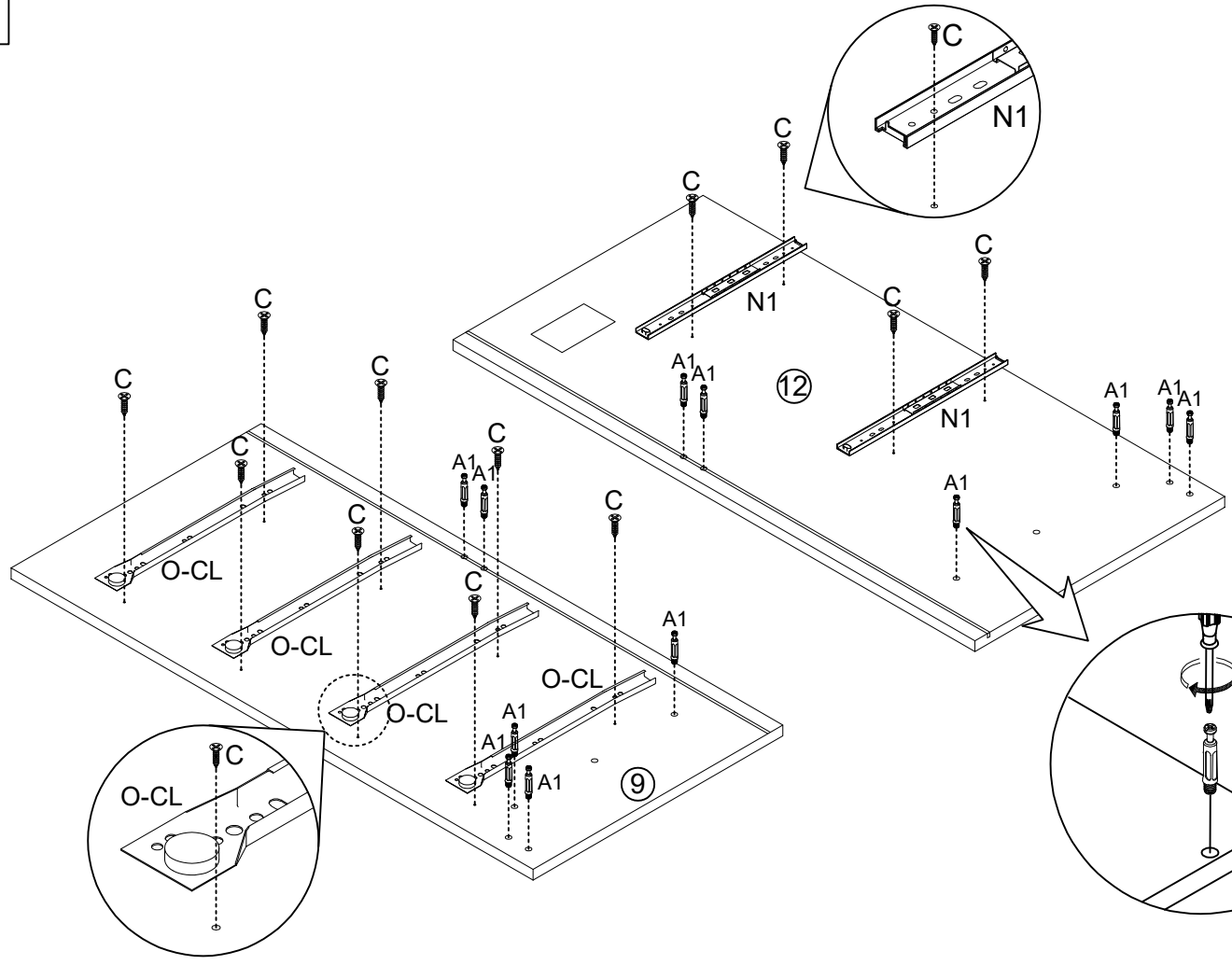

1

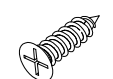
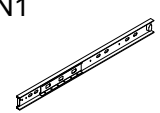
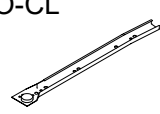

- A1  12PCS
- C  $\phi 3.5 \times 14$ 12PCS
- N1  2PCS
- O-CL  4PCS

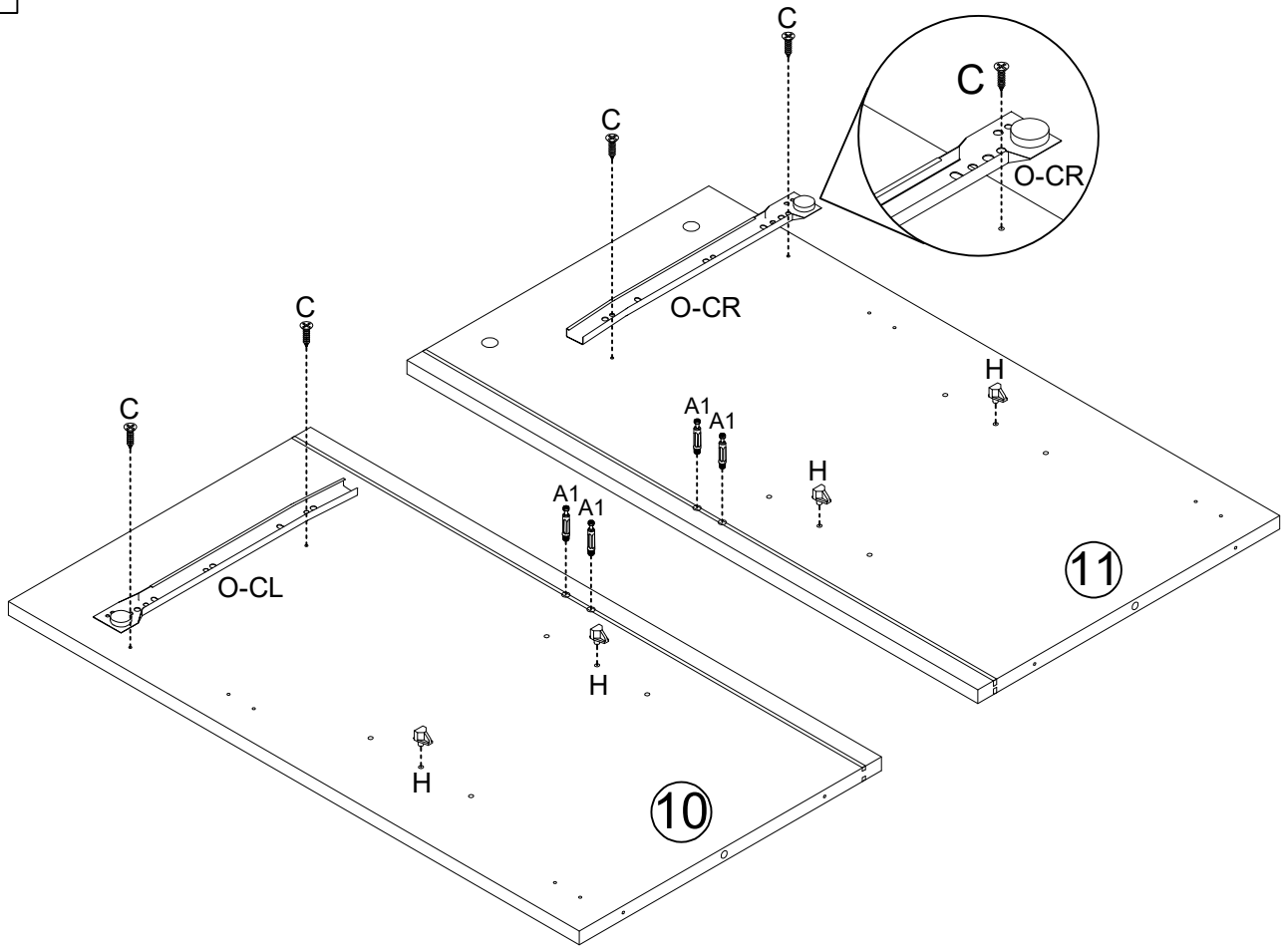
2

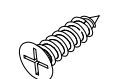

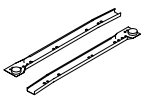
- A1  4PCS
- C  $\phi 3.5 \times 14$ 4PCS
- H  4PCS
- O-CL-CR  1PCS

3

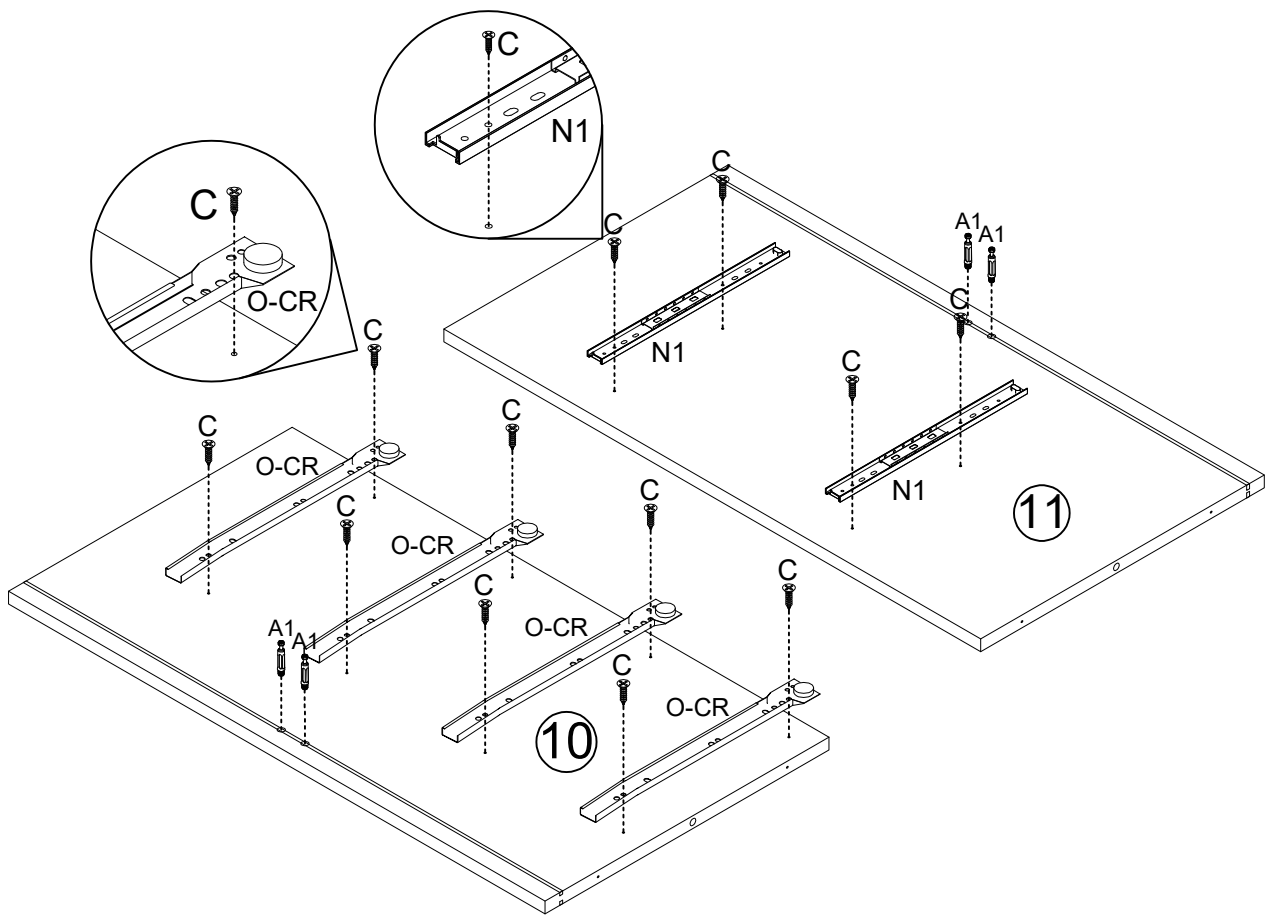

A1



4PCS

C

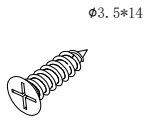

∅3.5*14

12PCS

N1

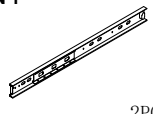

2PCS

O-CR

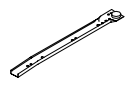

4PCS

4

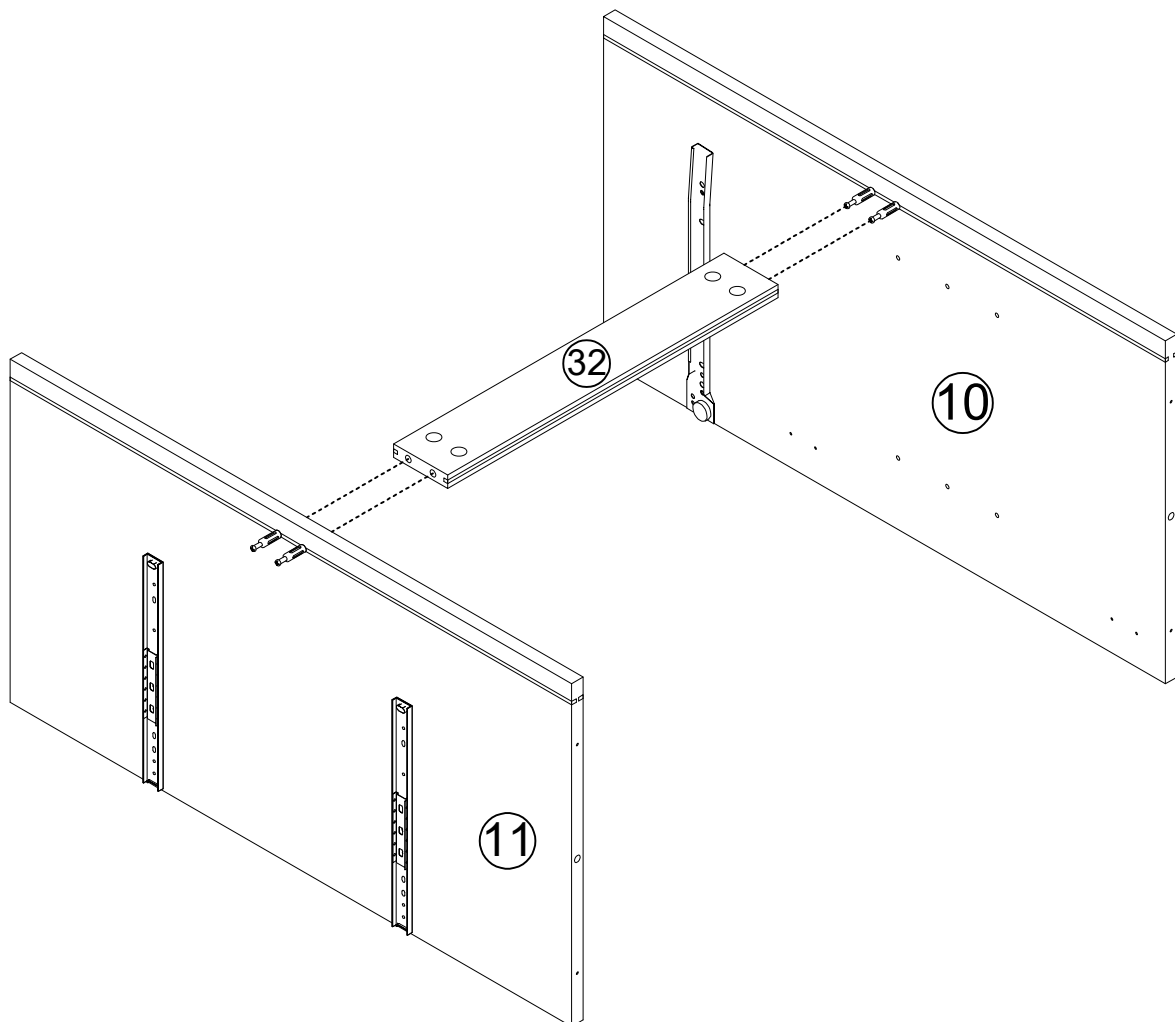

5

A2



4PCS

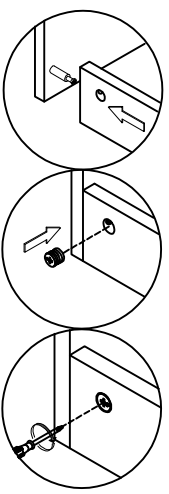
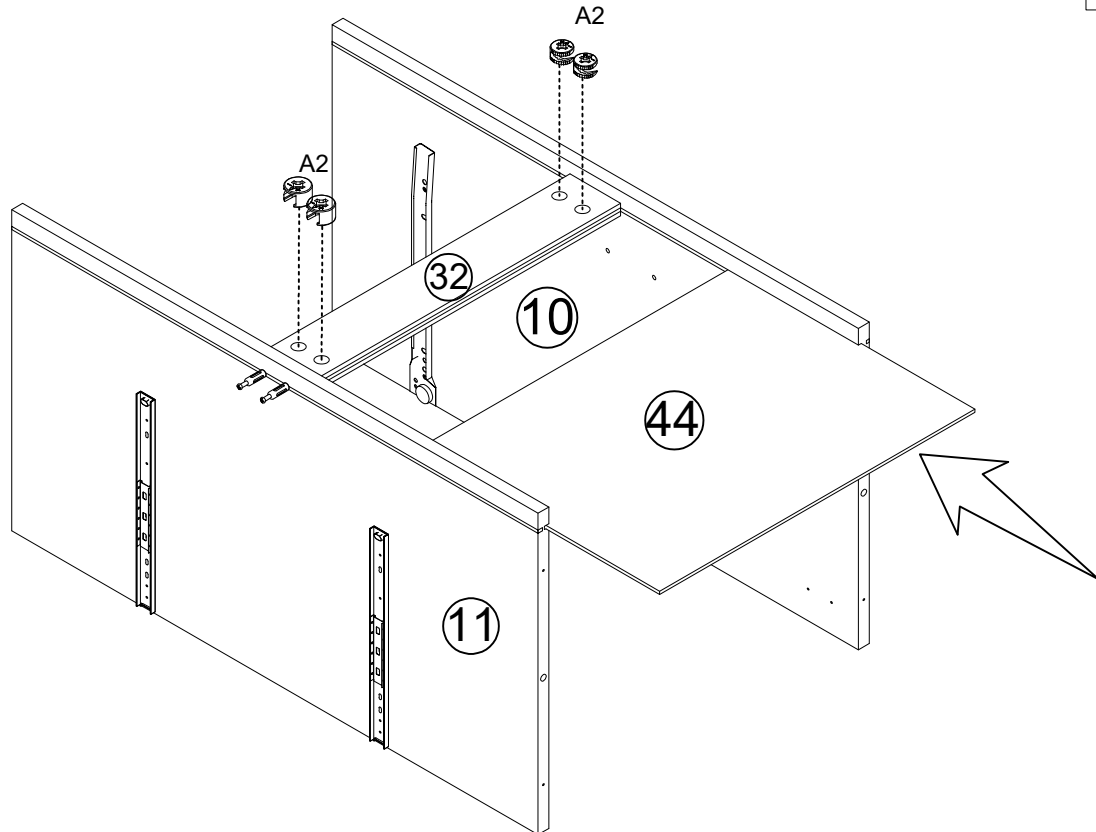

6

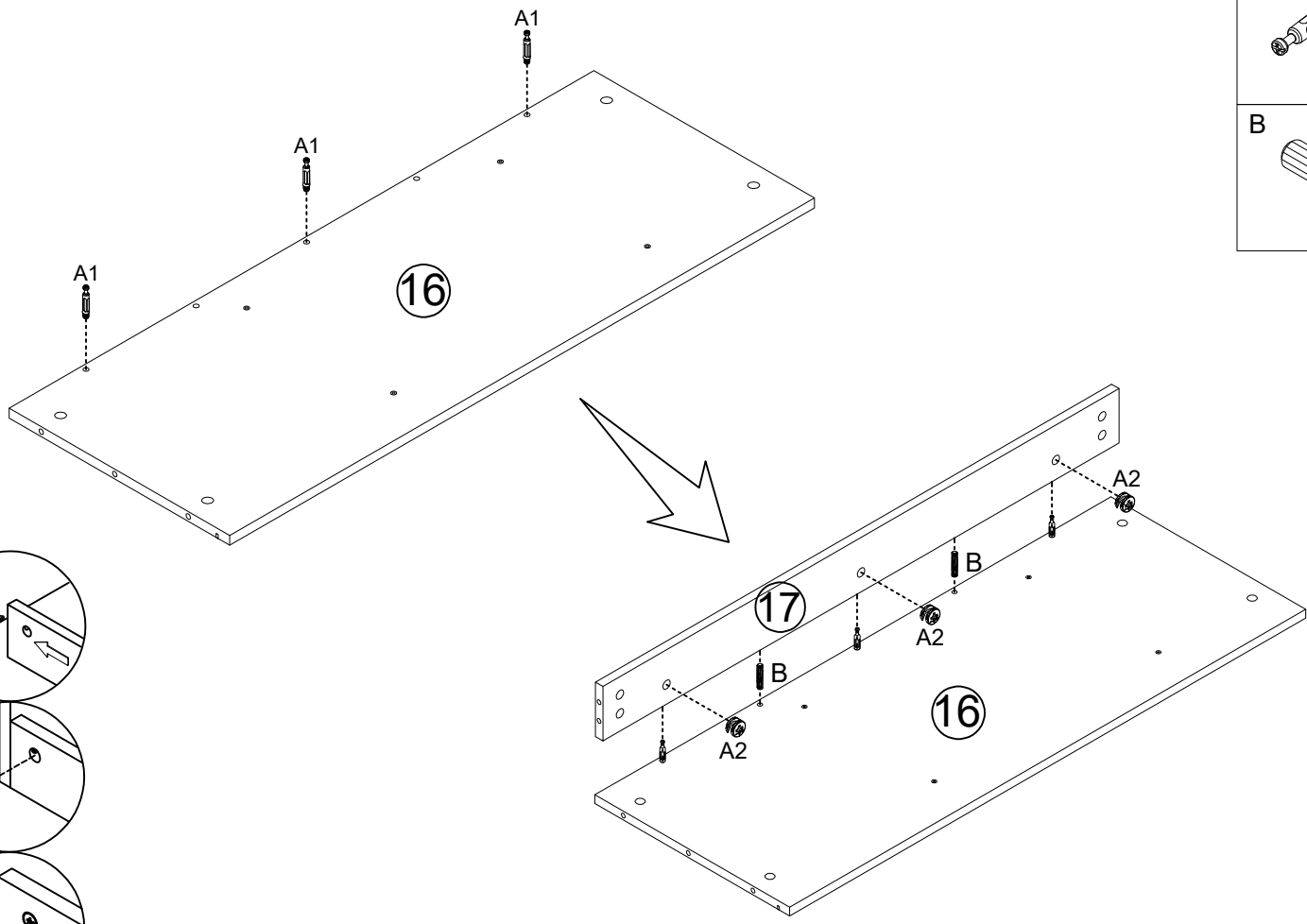

A

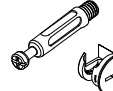

3PCS

B

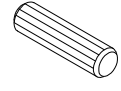

Ø8*40

2PCS

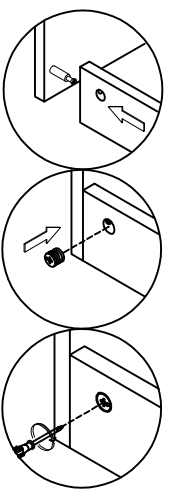

7

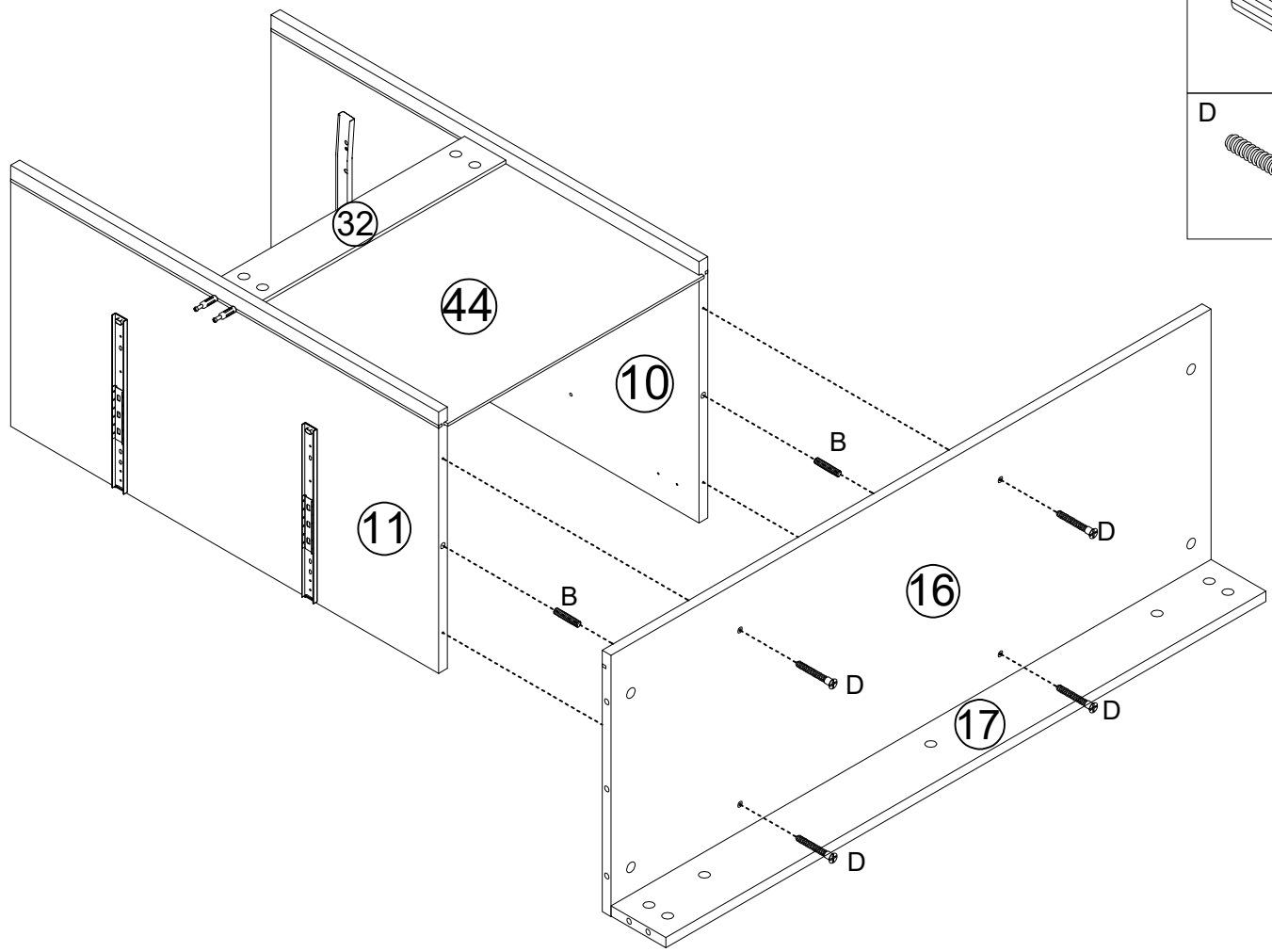

B $\varnothing 8 \times 40$
2PCS

D $\varnothing 5 \times 40$
4PCS

8

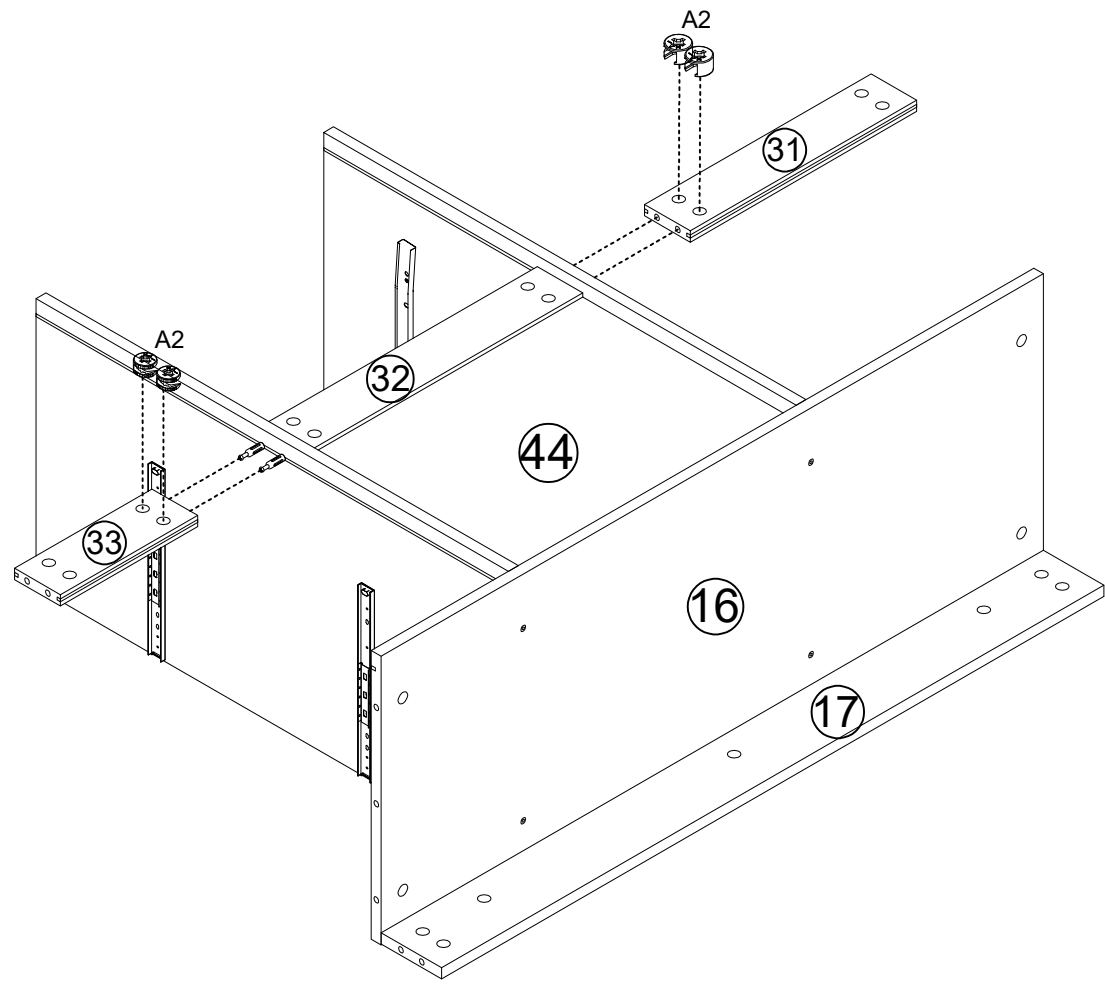

A2
4PCS

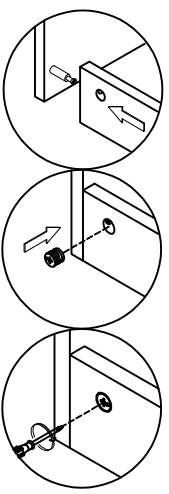

9

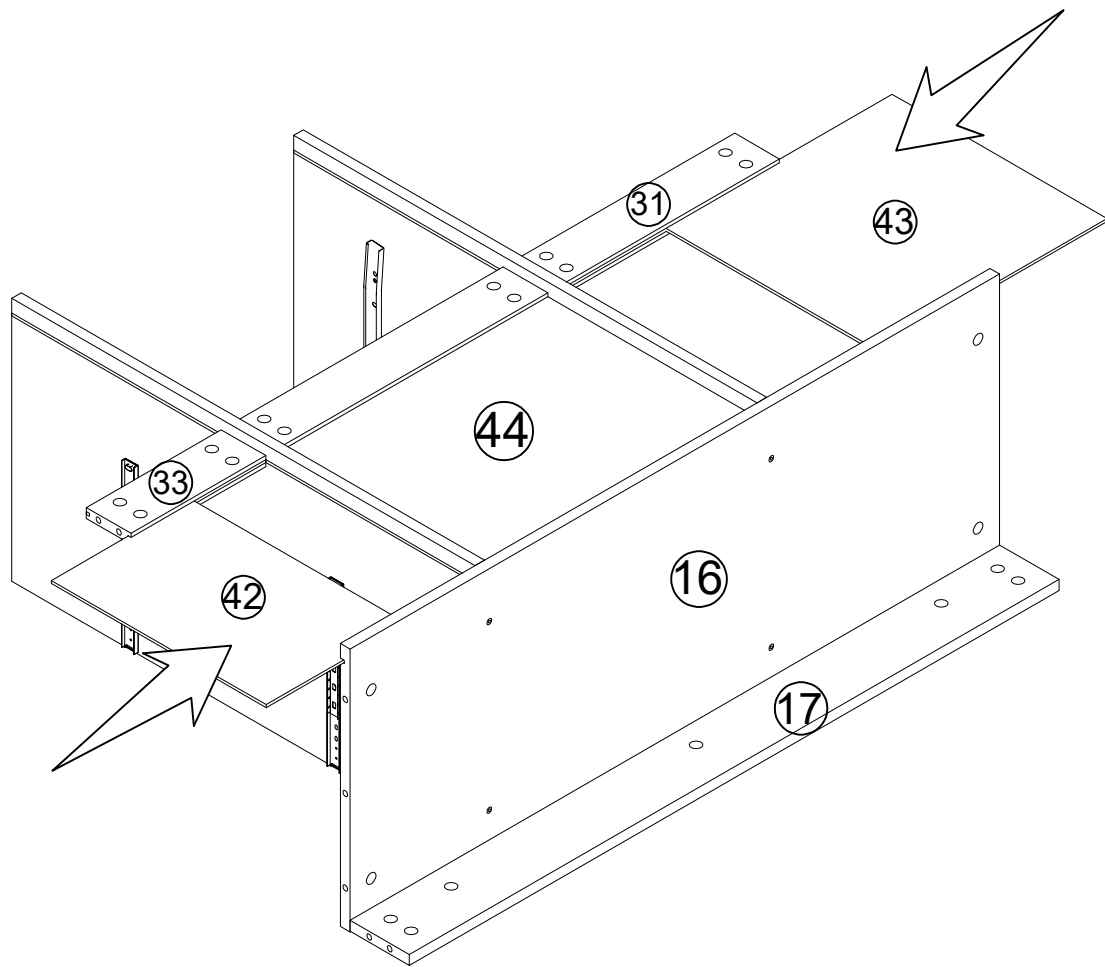

10

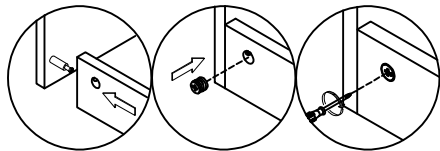

A2



12PCS

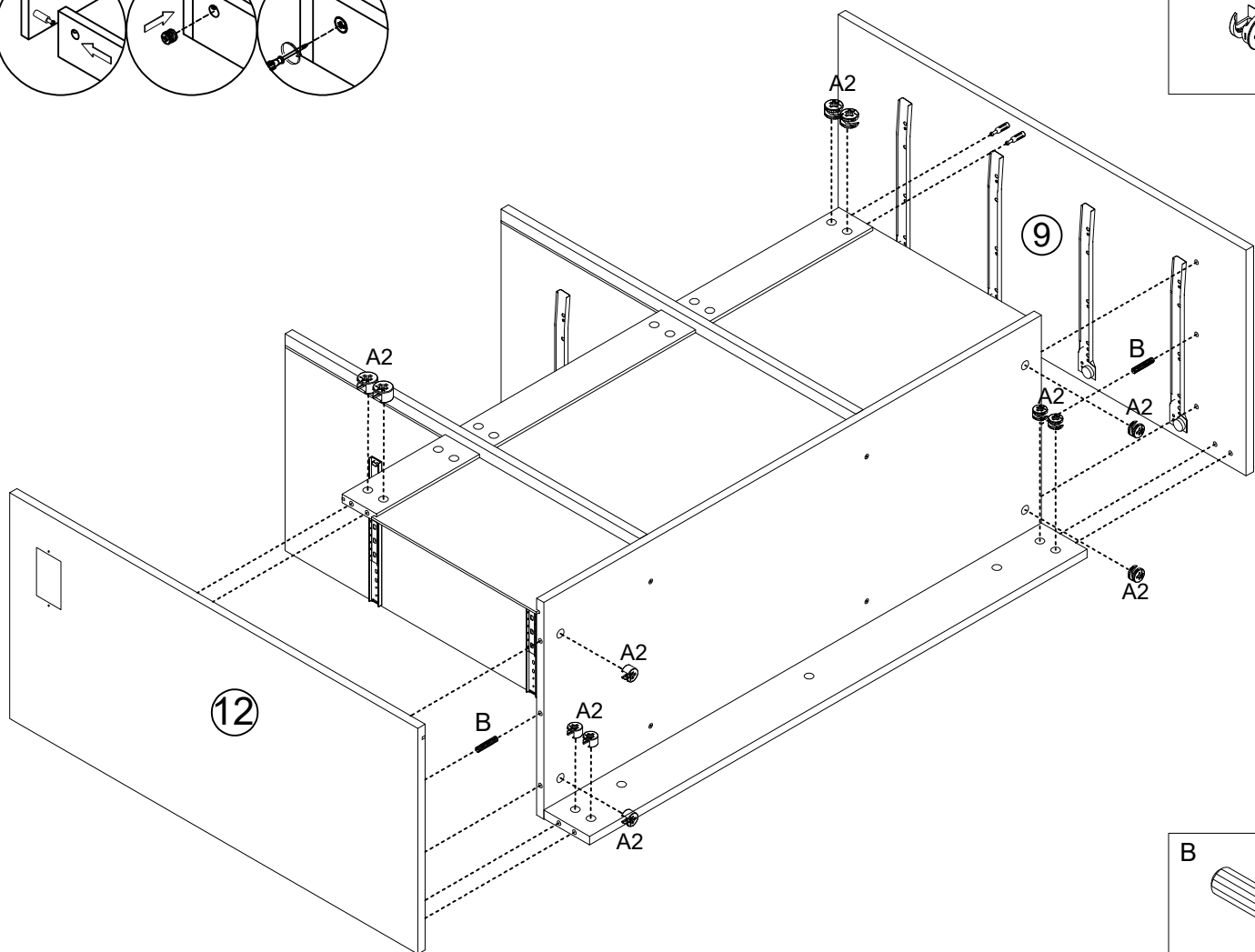

B

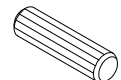

∅8*40

2PCS

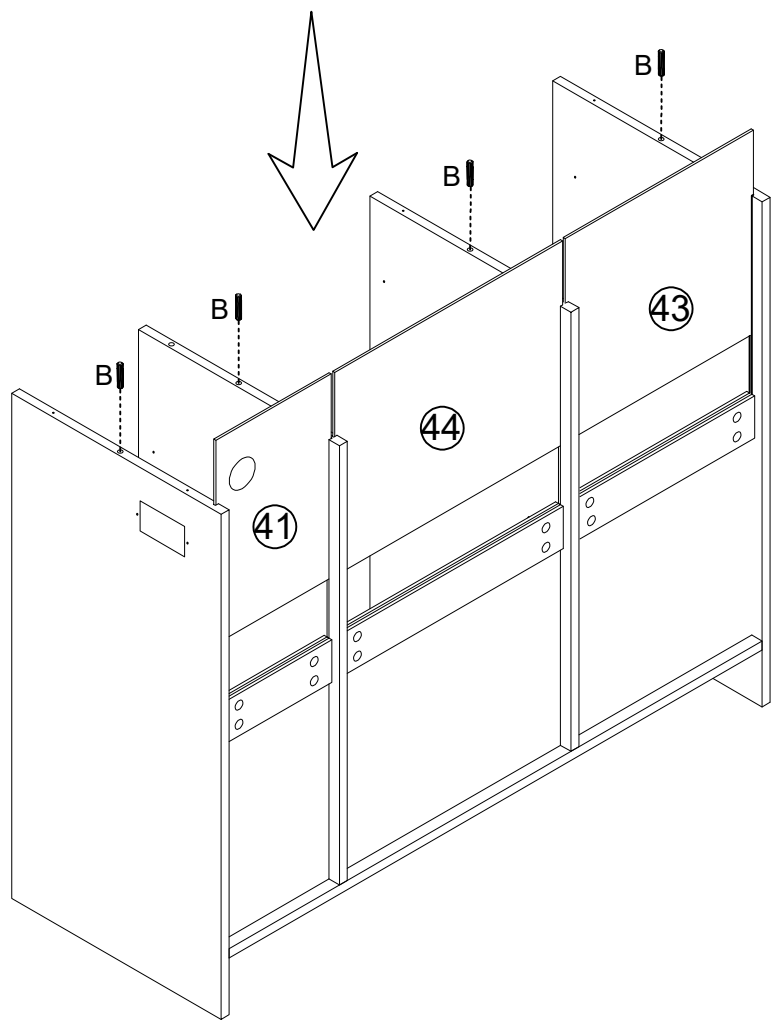

11

B $\phi 8*40$
4PCS

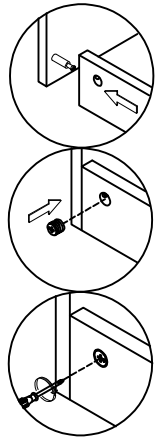
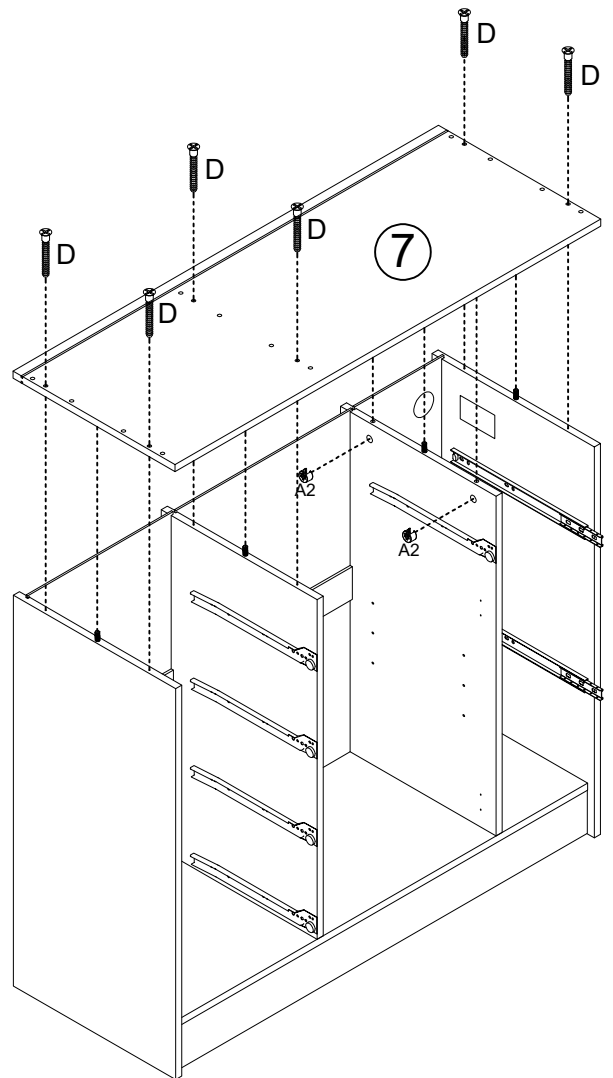
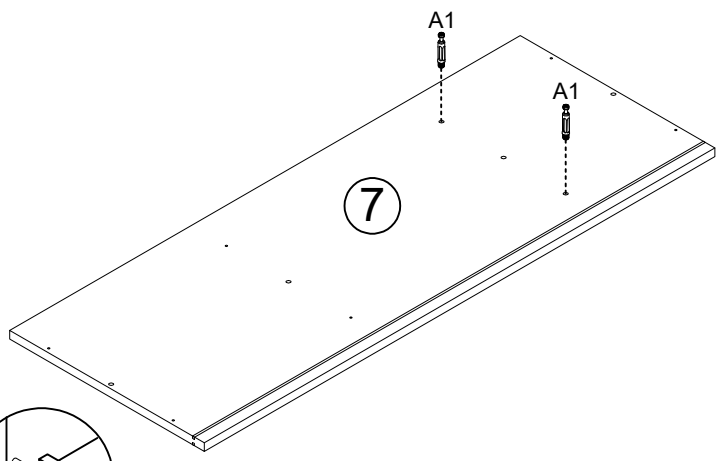

12

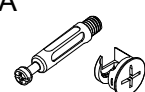

| | |
|--|---|
| <p>A</p>  <p>2PCS</p> | <p>D</p> <p>$\phi 5*40$</p>  <p>6PCS</p> |
|--|---|

13

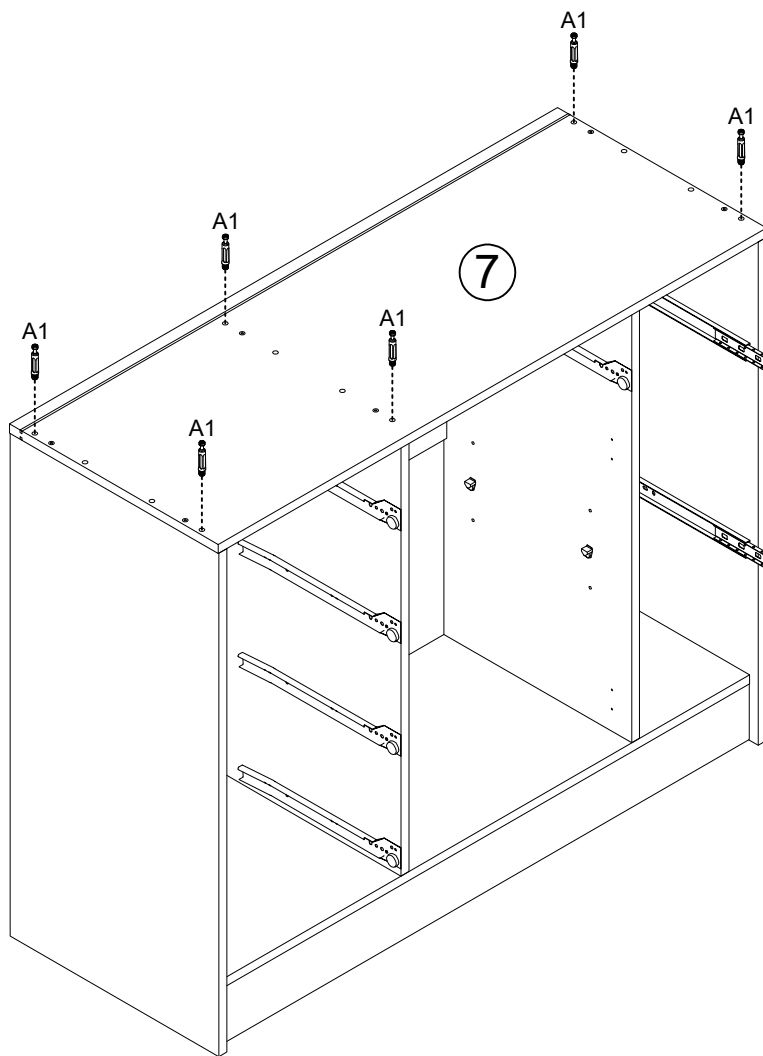

A1

6PCS

14

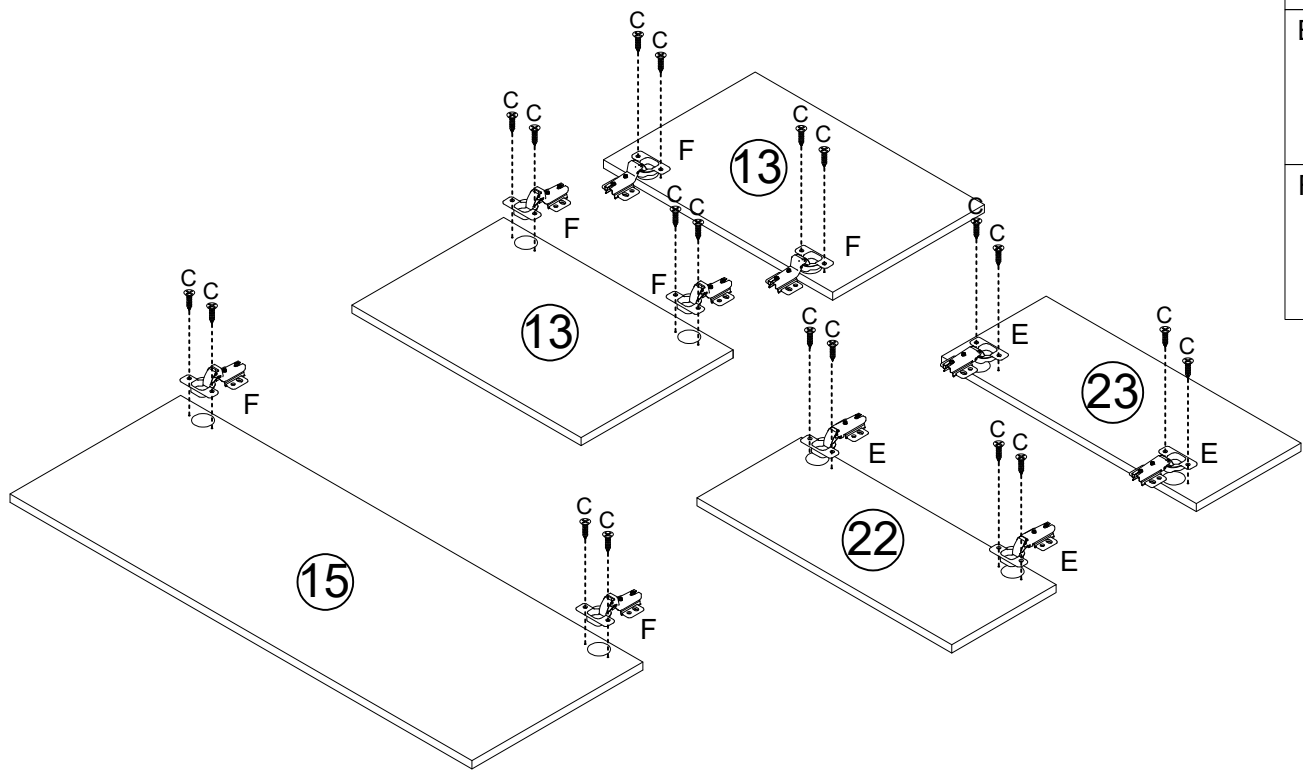

C $\varnothing 3.5 \times 14$

20PCS

E

4PCS

F

6PCS

15

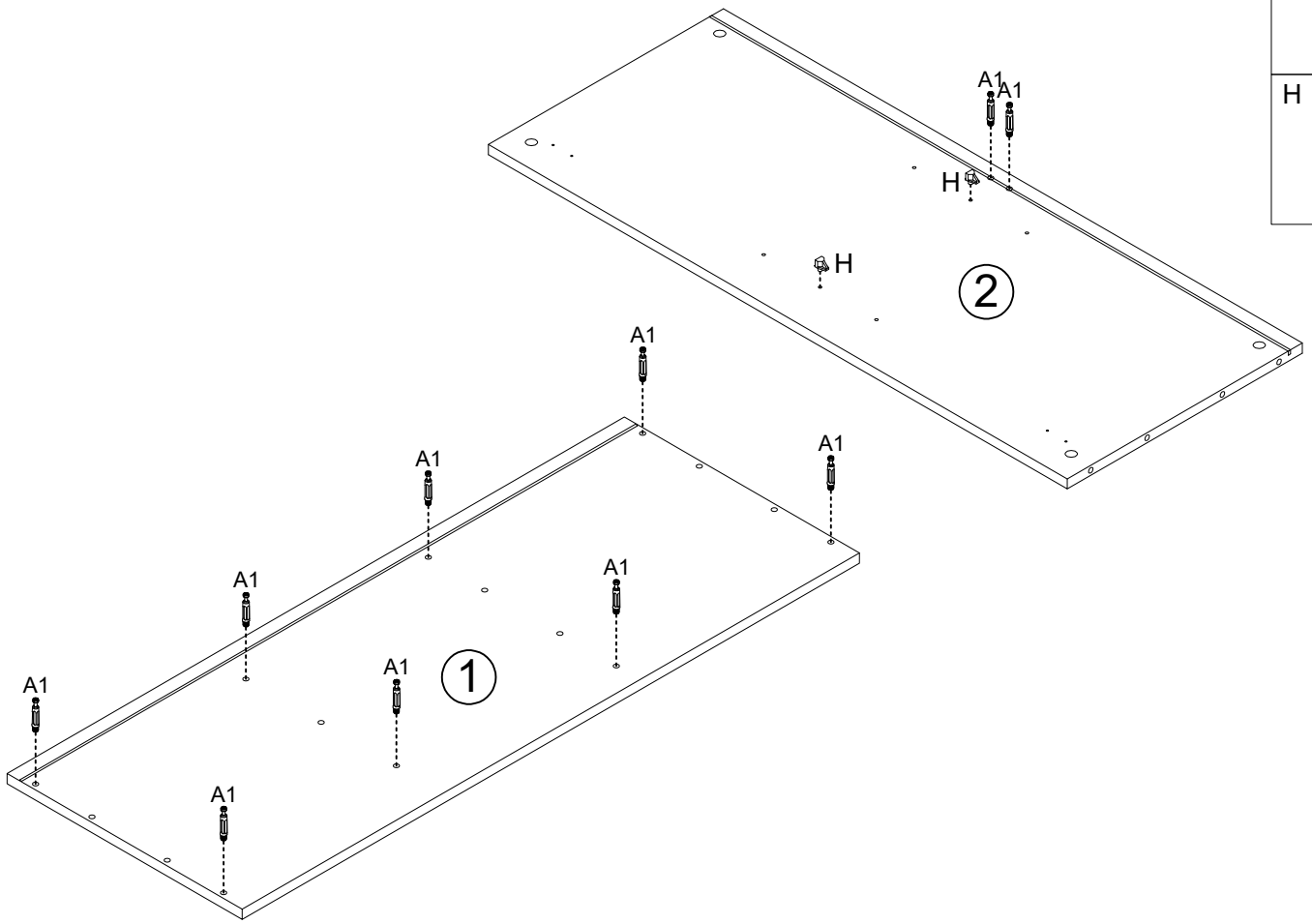

A1



10PCS

H



2PCS

16

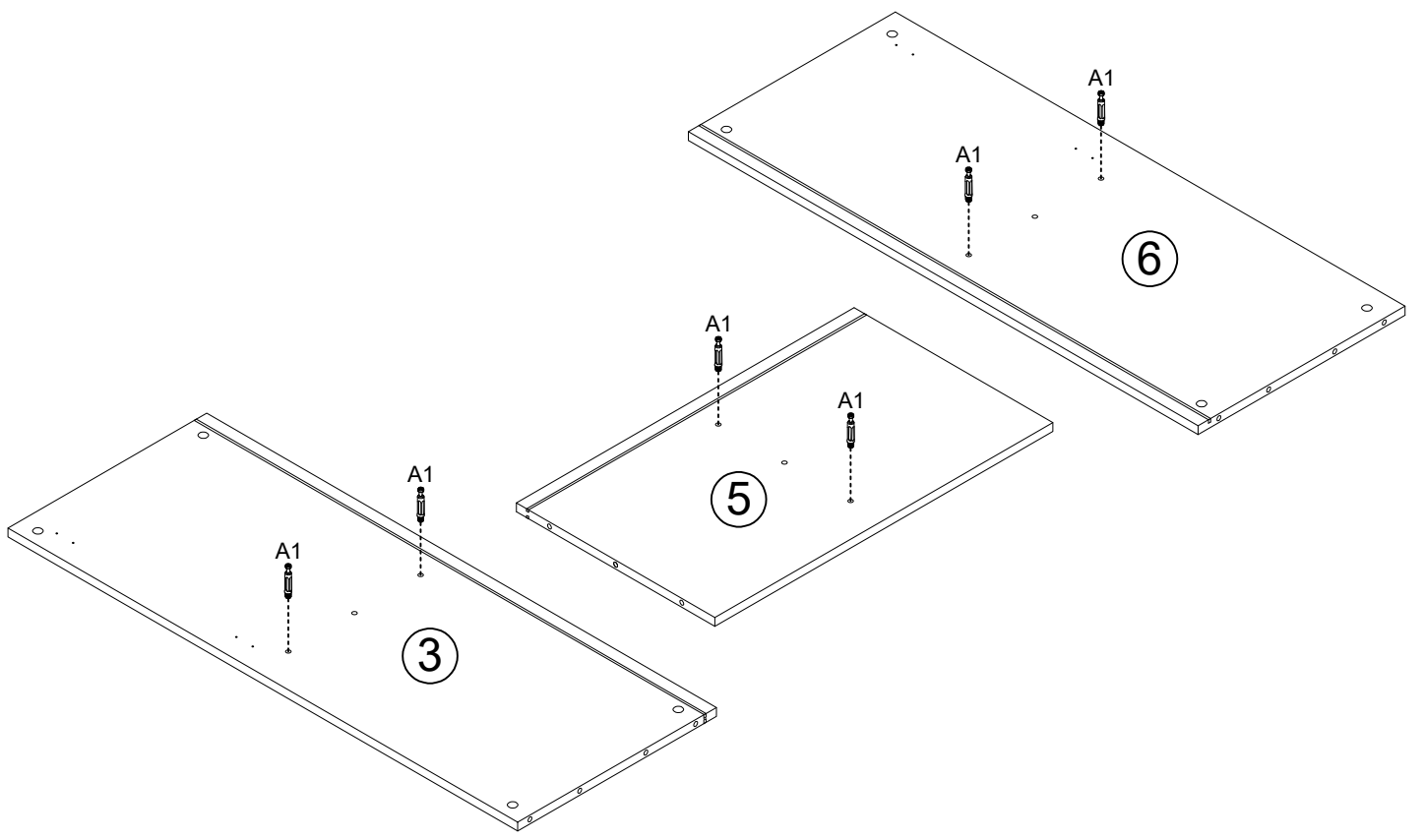



A1

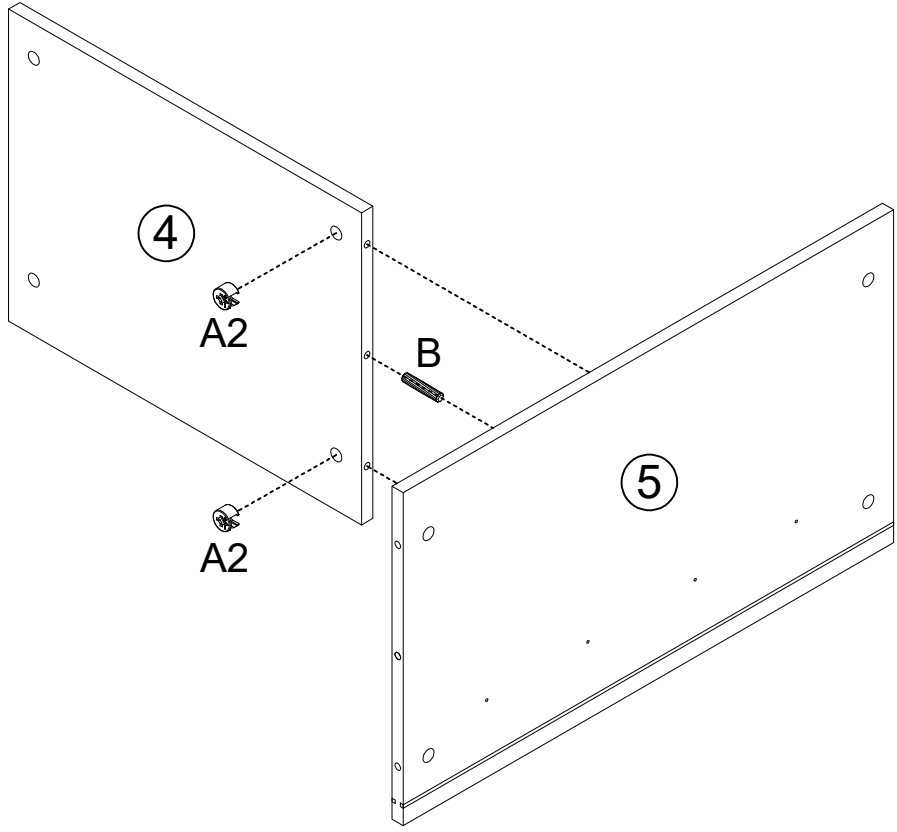

6PCS

17



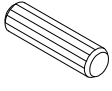

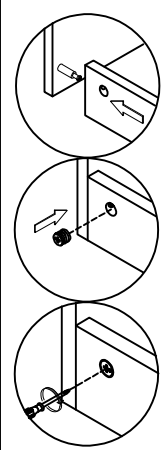
| | | |
|----|---|------|
| A2 |  | 2PCS |
| B |  | 1PC |

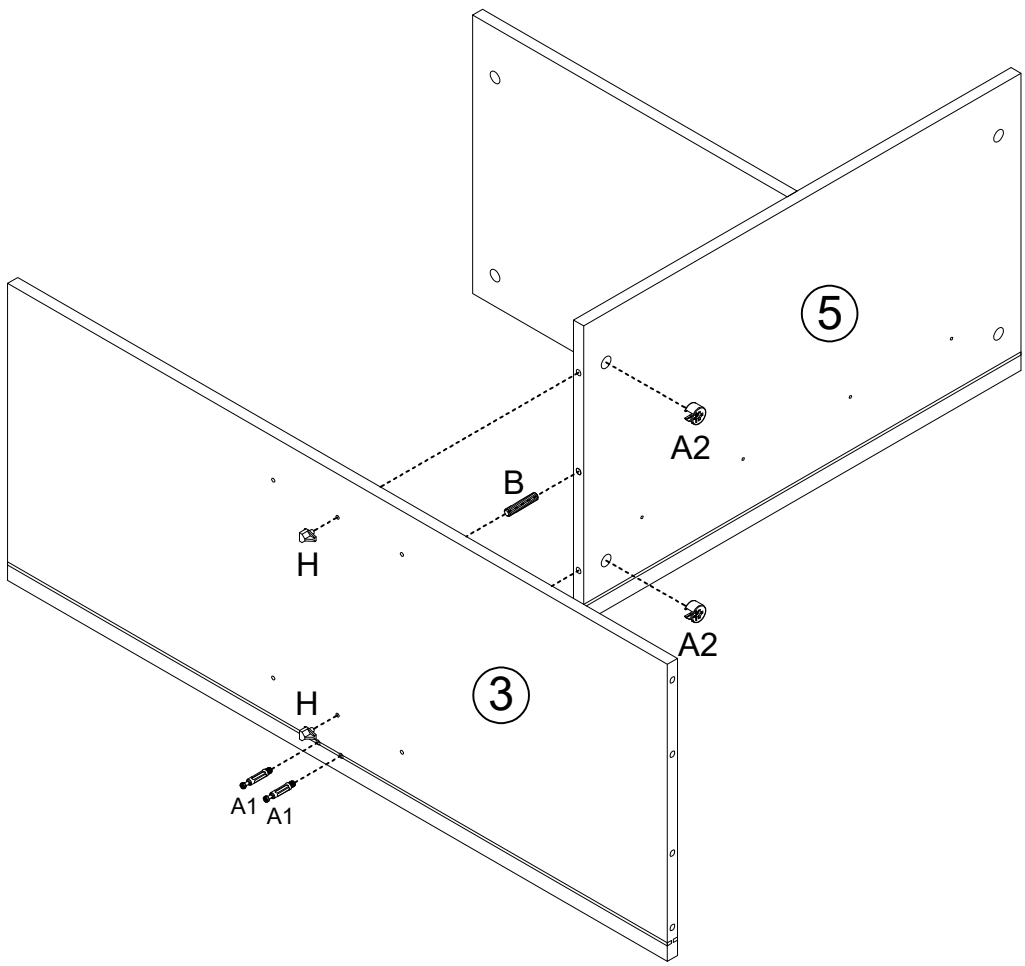

18

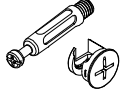
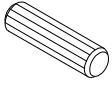

| | | |
|----|---|------|
| A2 |  | 2PCS |
| B |  | 1PC |
| H |  | 2PCS |

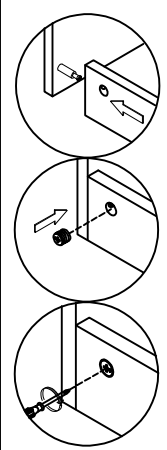

19

A2



2PCS

B

Ø8*40

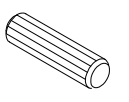

1PC

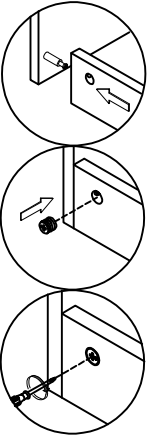
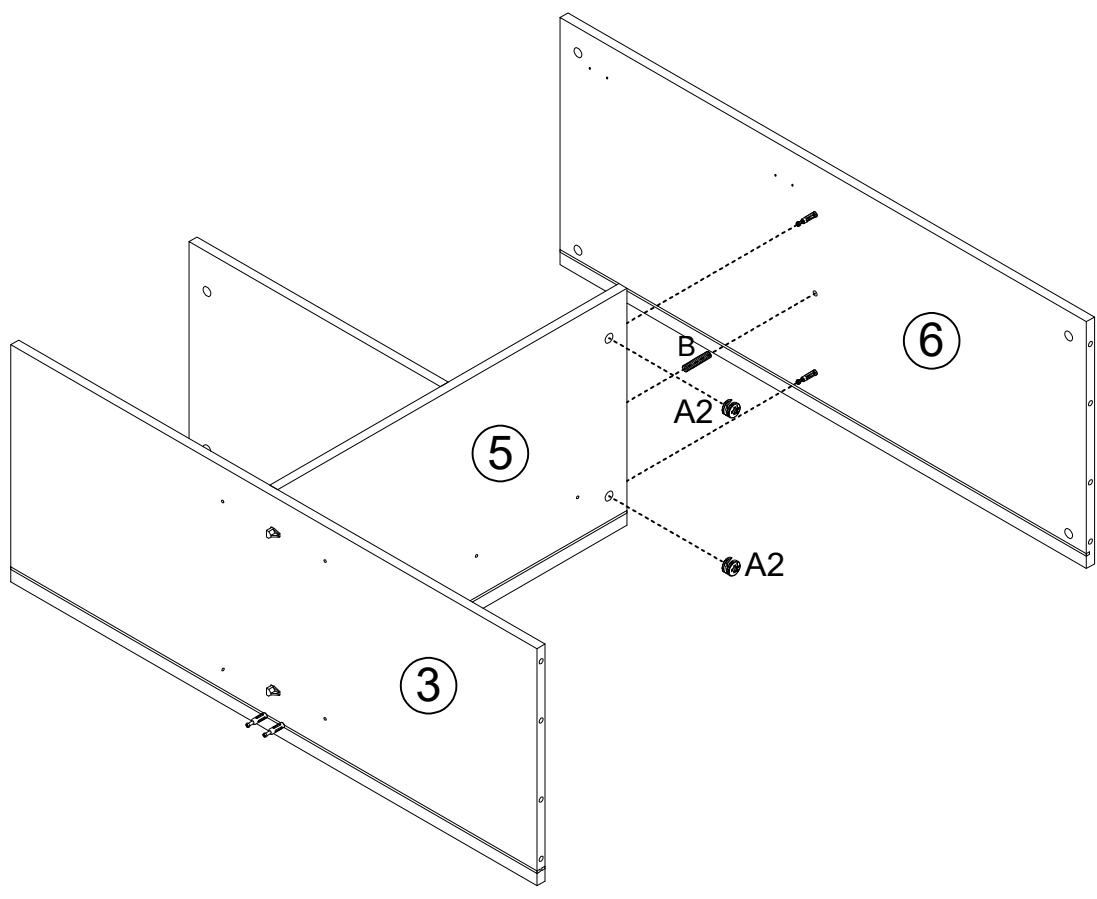

20

A2



2PCS

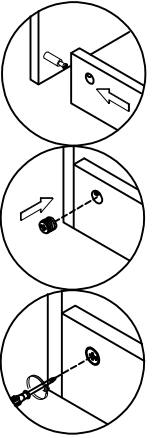
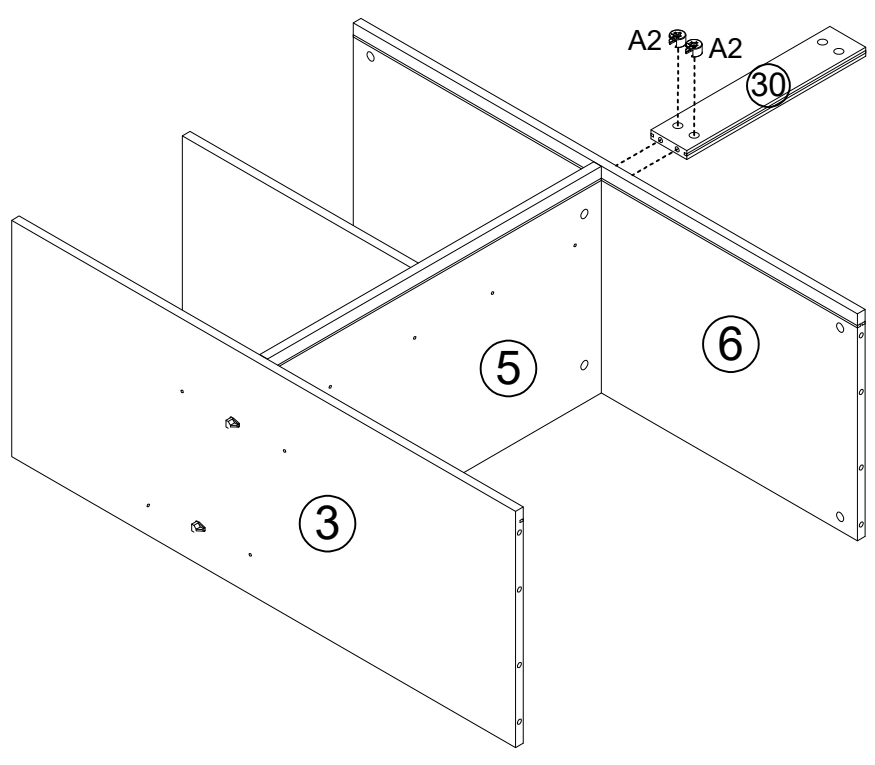

21

A2



2PCS

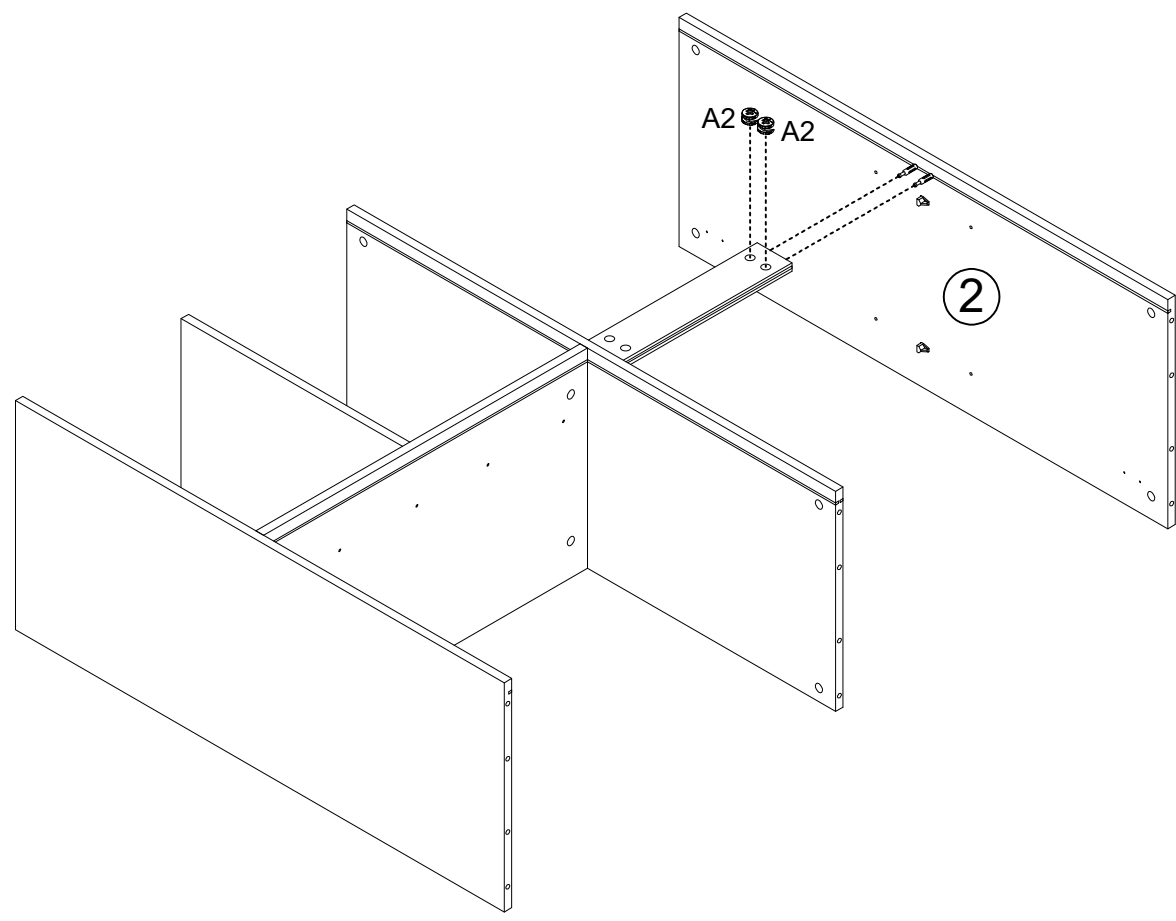





22

498MM

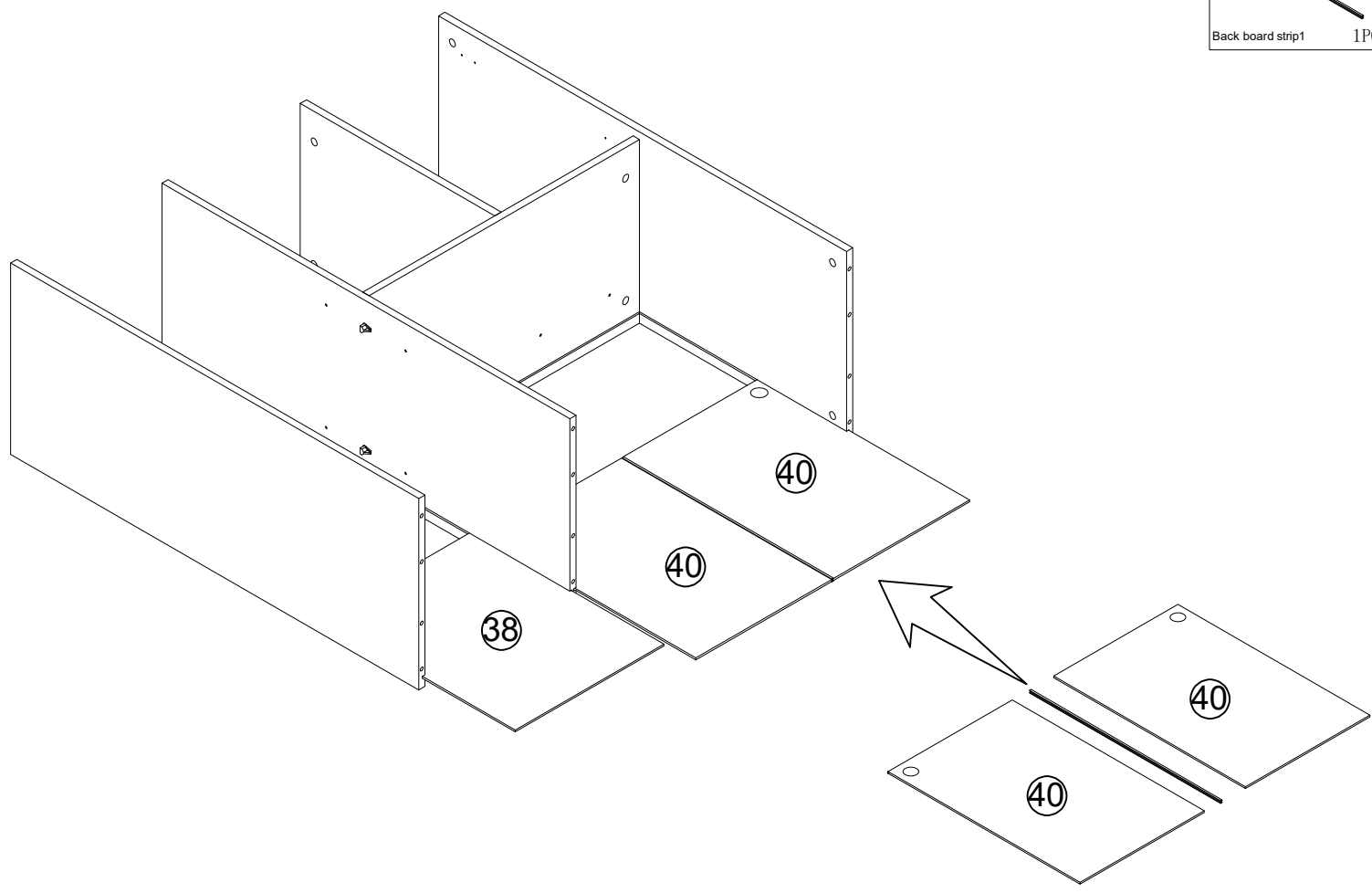
Back board strip1

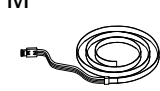
1PC



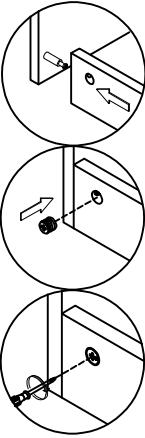
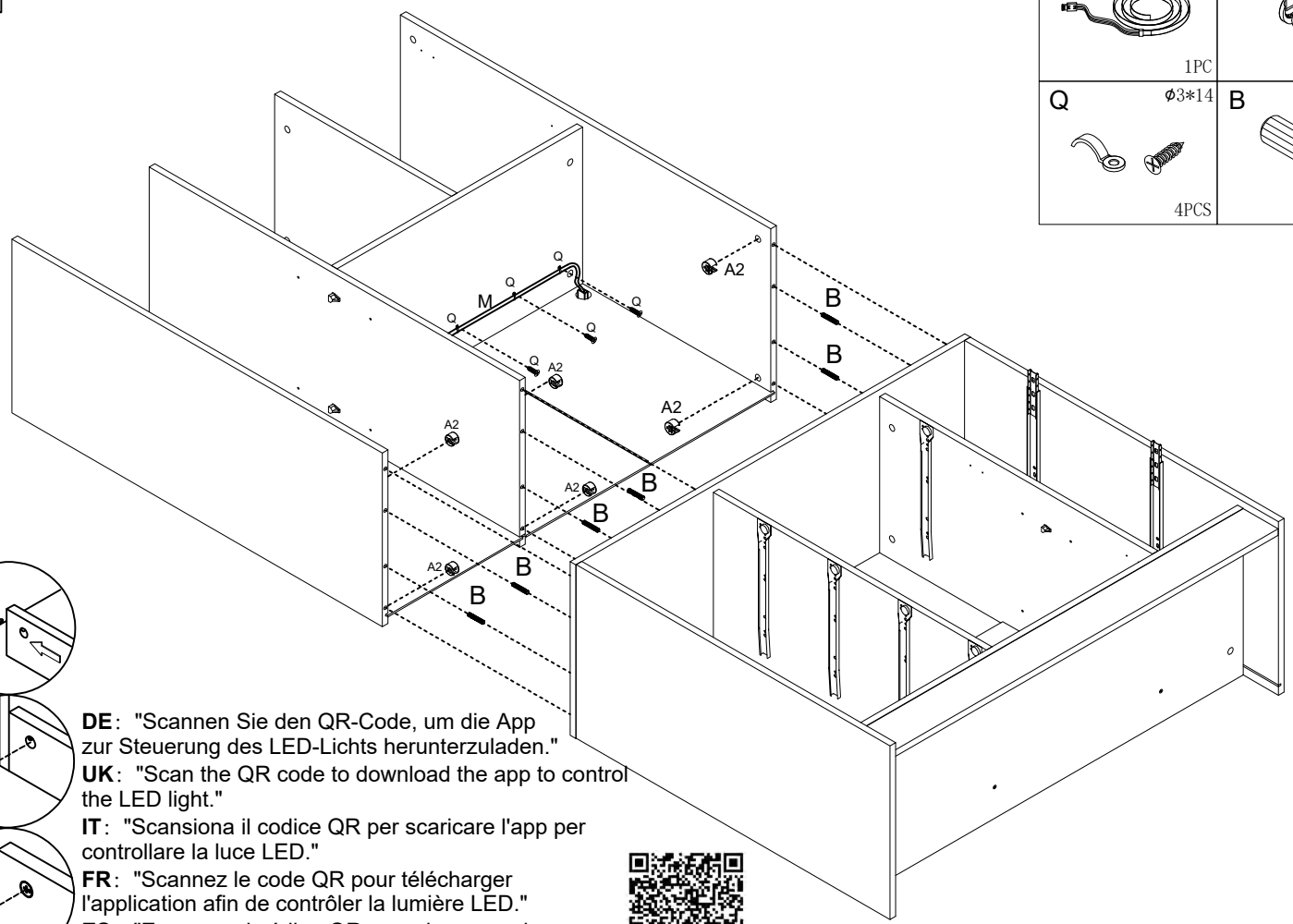

| | | | |
|---|---|----|---|
| M |  | A2 |  |
| | 1PC | | 6PCS |
| Q |  | B |  |
| | 4PCS | | 6PCS |



DE: "Scannen Sie den QR-Code, um die App zur Steuerung des LED-Lichts herunterzuladen."
UK: "Scan the QR code to download the app to control the LED light."
IT: "Scansiona il codice QR per scaricare l'app per controllare la luce LED."
FR: "Scannez le code QR pour télécharger l'application afin de contrôler la lumière LED."
ES: "Escanea el código QR para descargar la aplicación y controlar la luz LED."

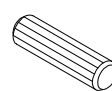

| | | |
|---|---|---------|
| B |  | Ø8*40 |
| | | 7PCS |
| C |  | Ø3.5*14 |
| | | 2PCS |
| J |  | |
| | | 1PC |
| | | 468MM |
| | Back board strip2 | 1PC |

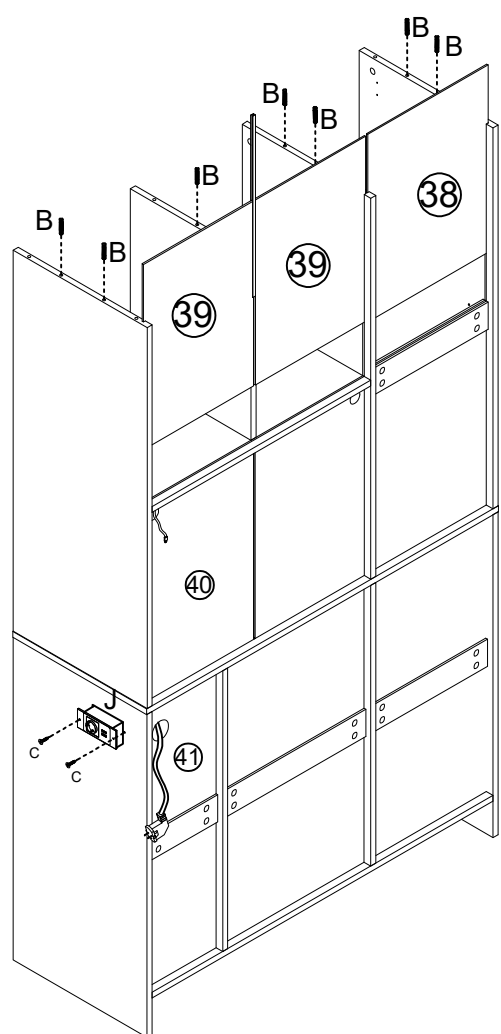

25

A2



8PCS

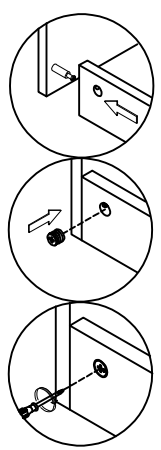
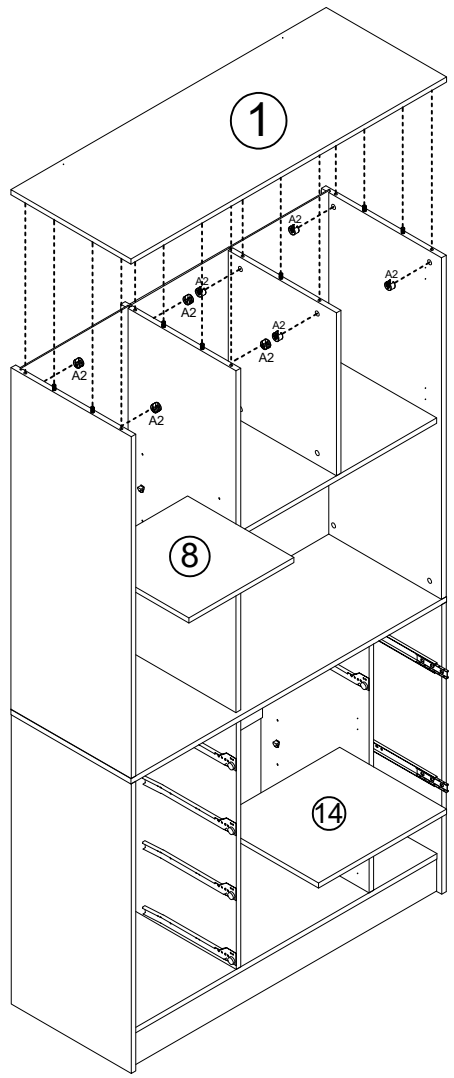

26

C

Ø3.5*14



12PCS

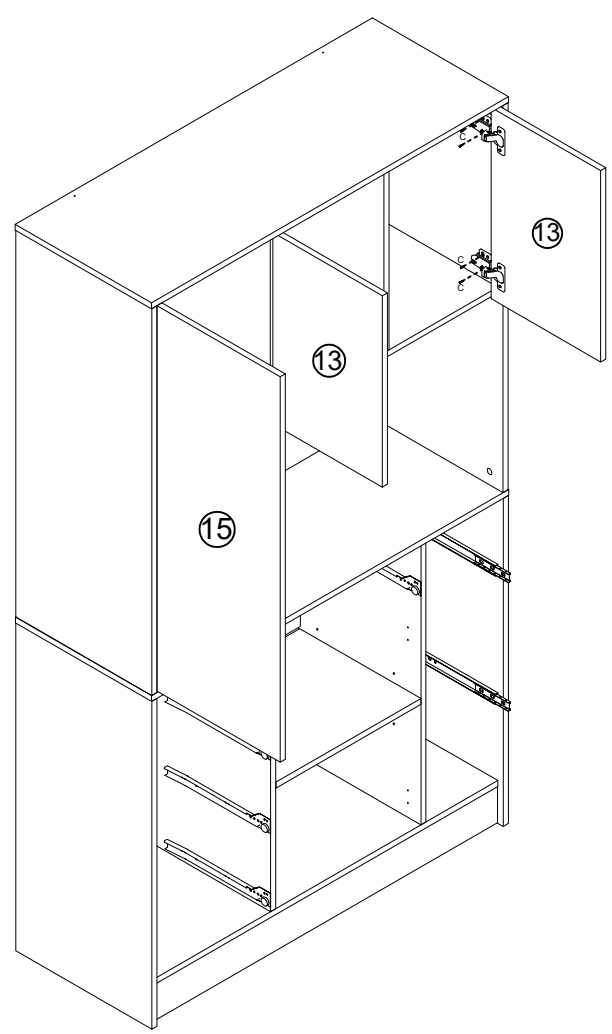
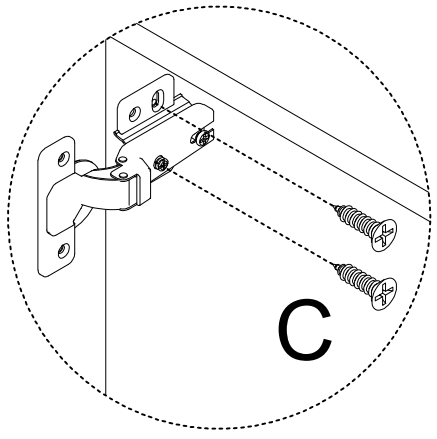

27

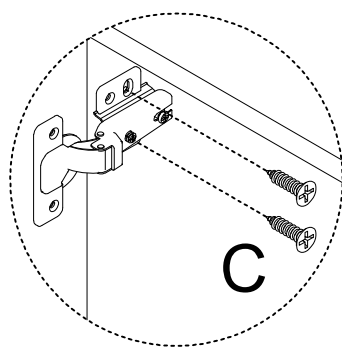
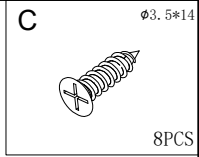
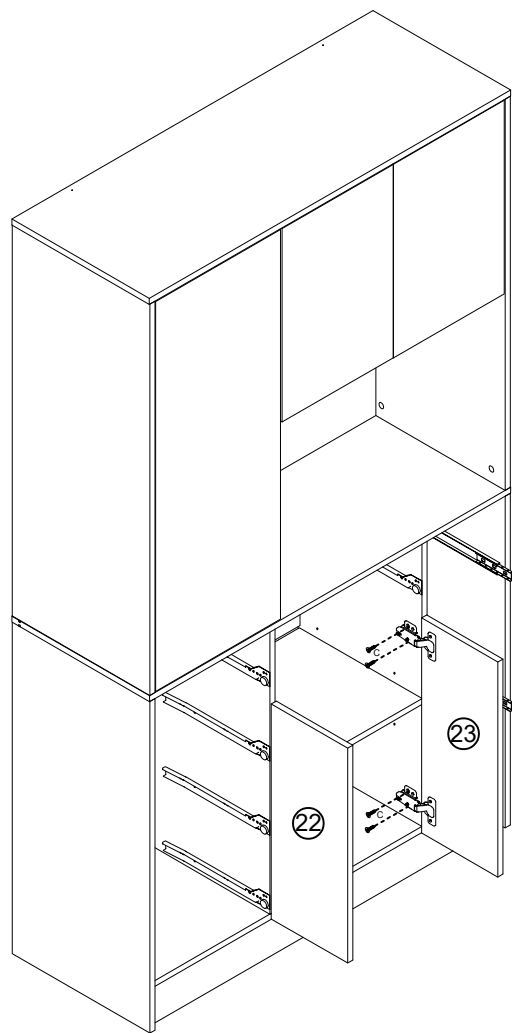

28

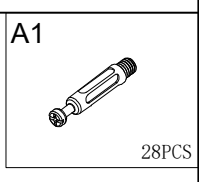
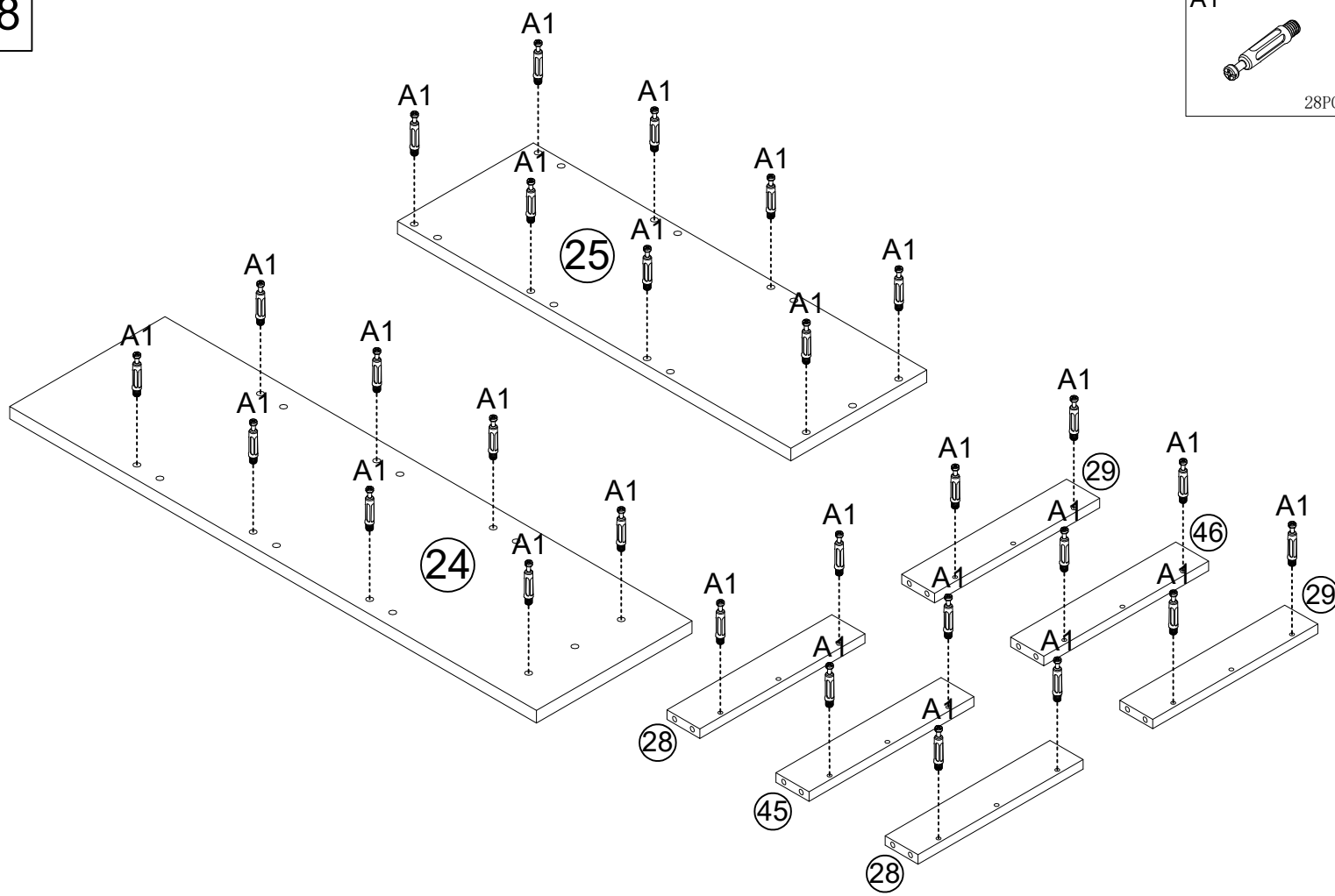

29

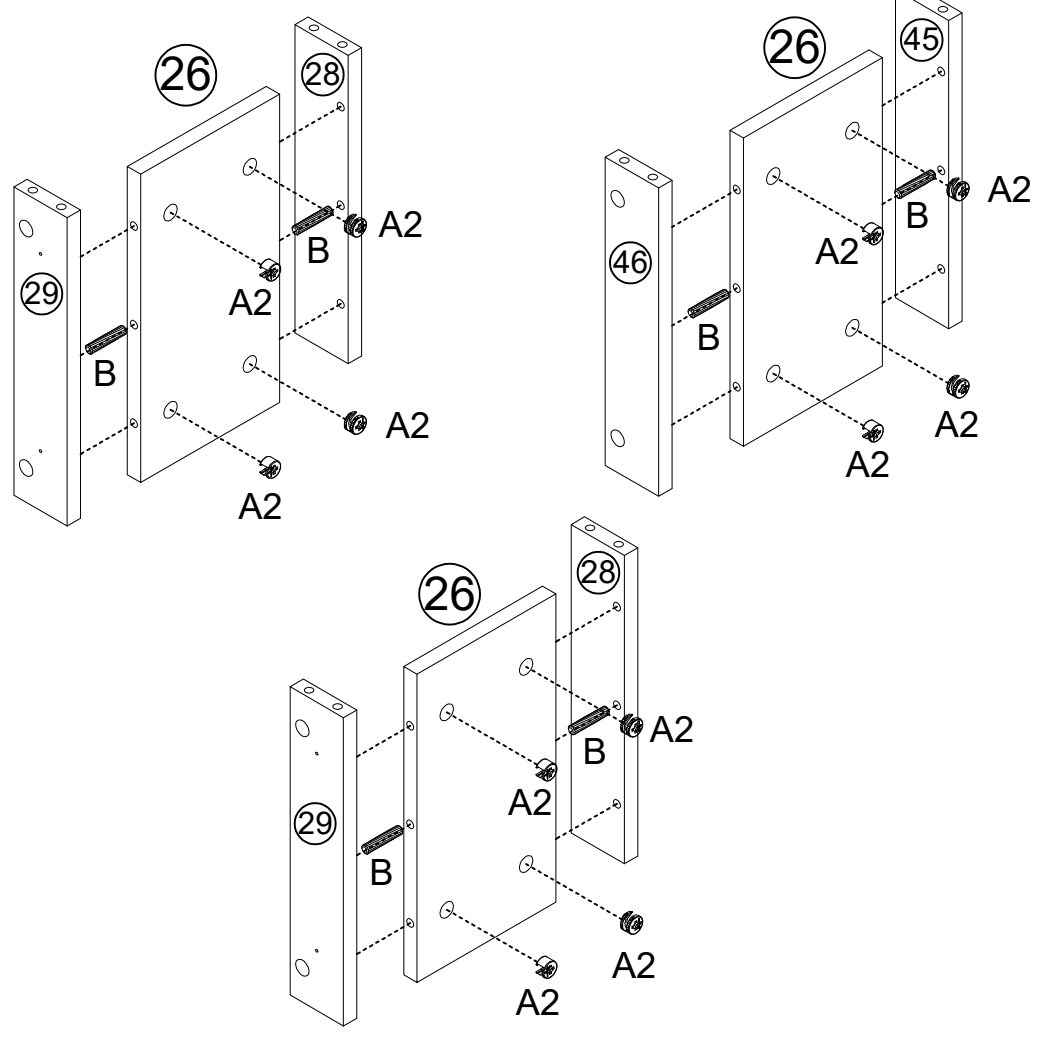

A2



12PCS

B

Ø8*40

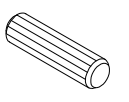

6PCS

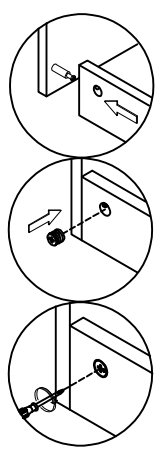

30

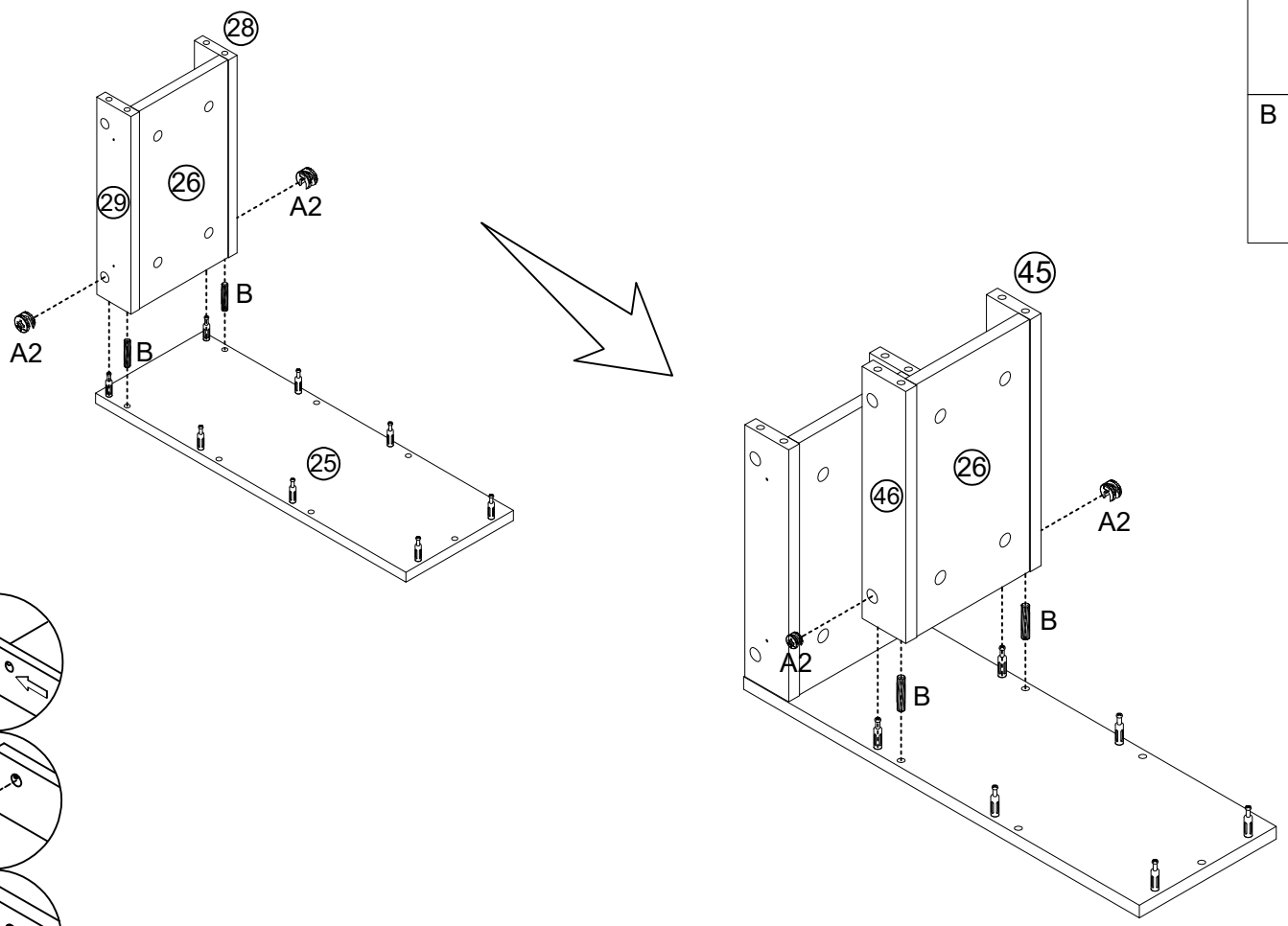

A2



4PCS

B

Ø8*40

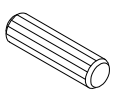

4PCS

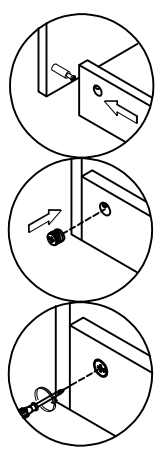

31

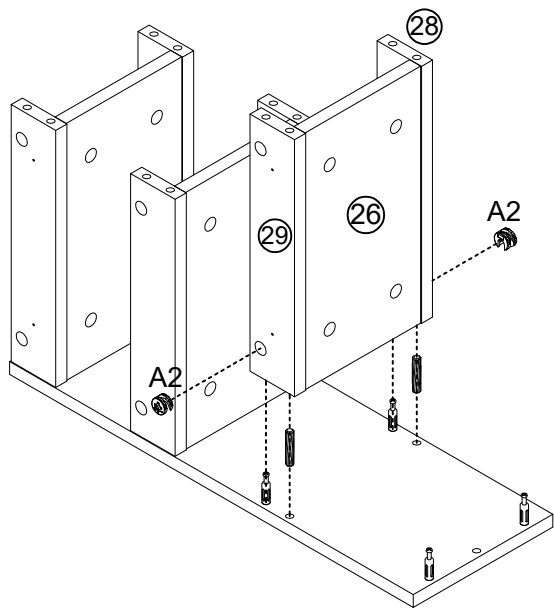

A2



4PCS

B

Ø8*40

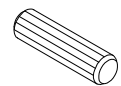

3PCS

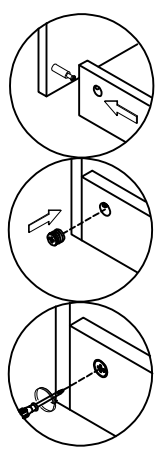
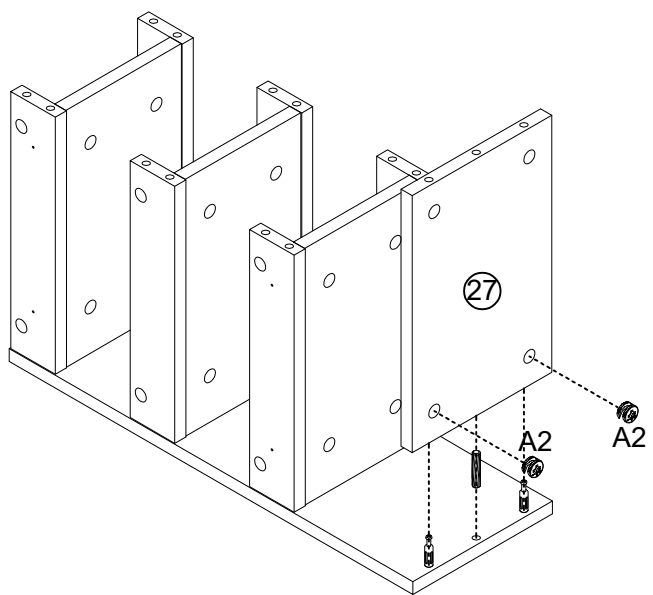

32

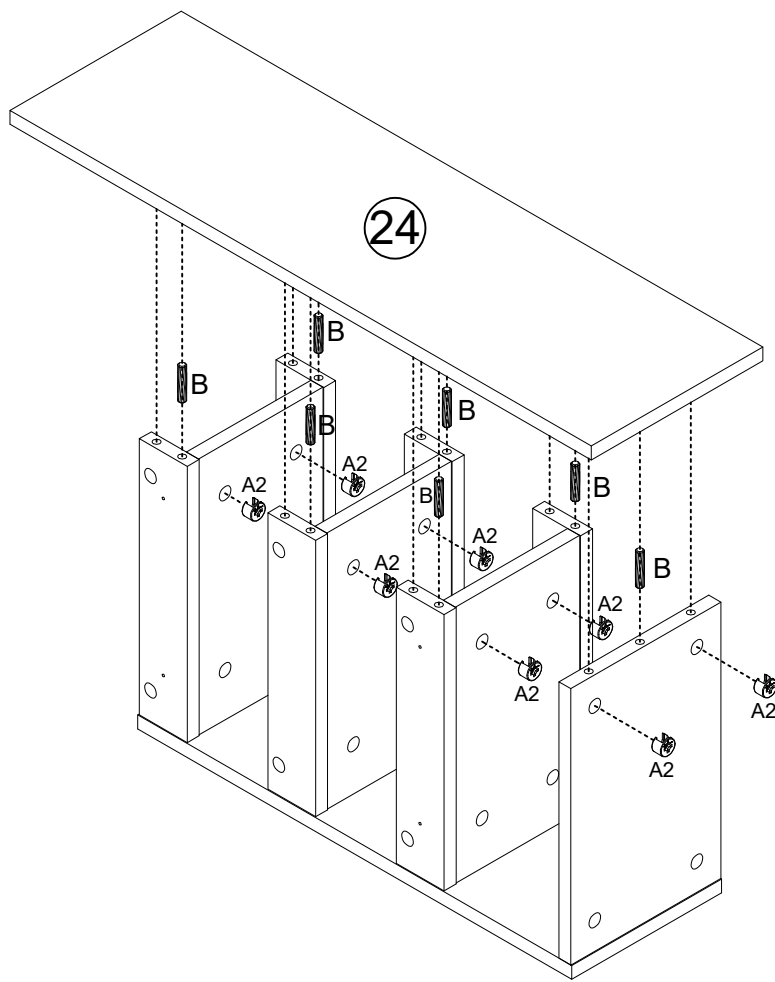

A2



8PCS

B

Ø8*40

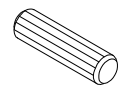

7PCS

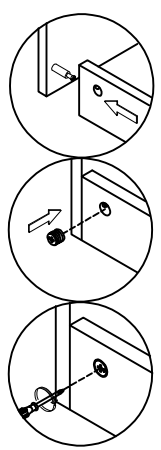

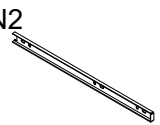

33

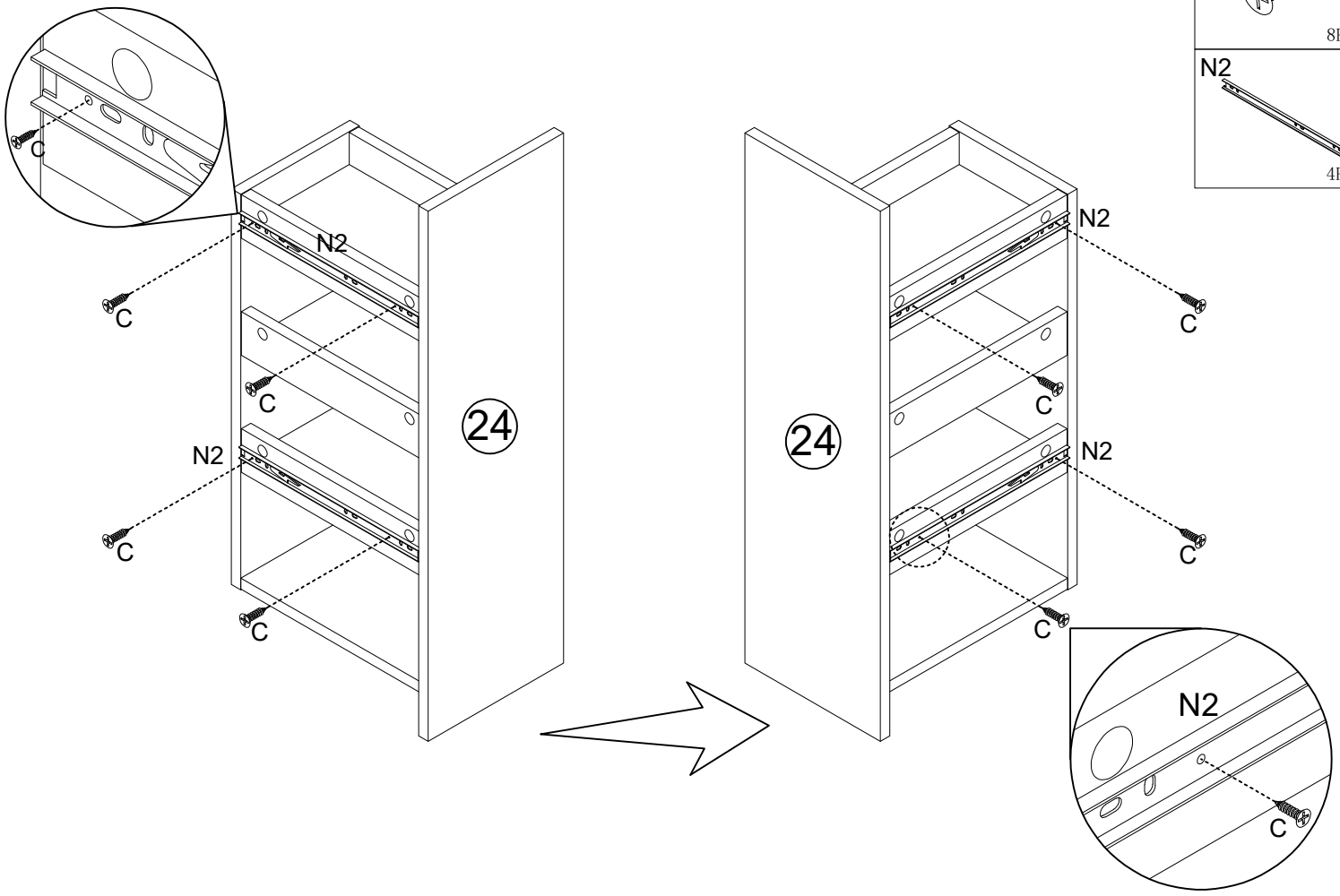
| | | |
|----|---|-----------------|
| C |  | Ø3.5*14 8PCS |
| N2 |  | 4PCS |



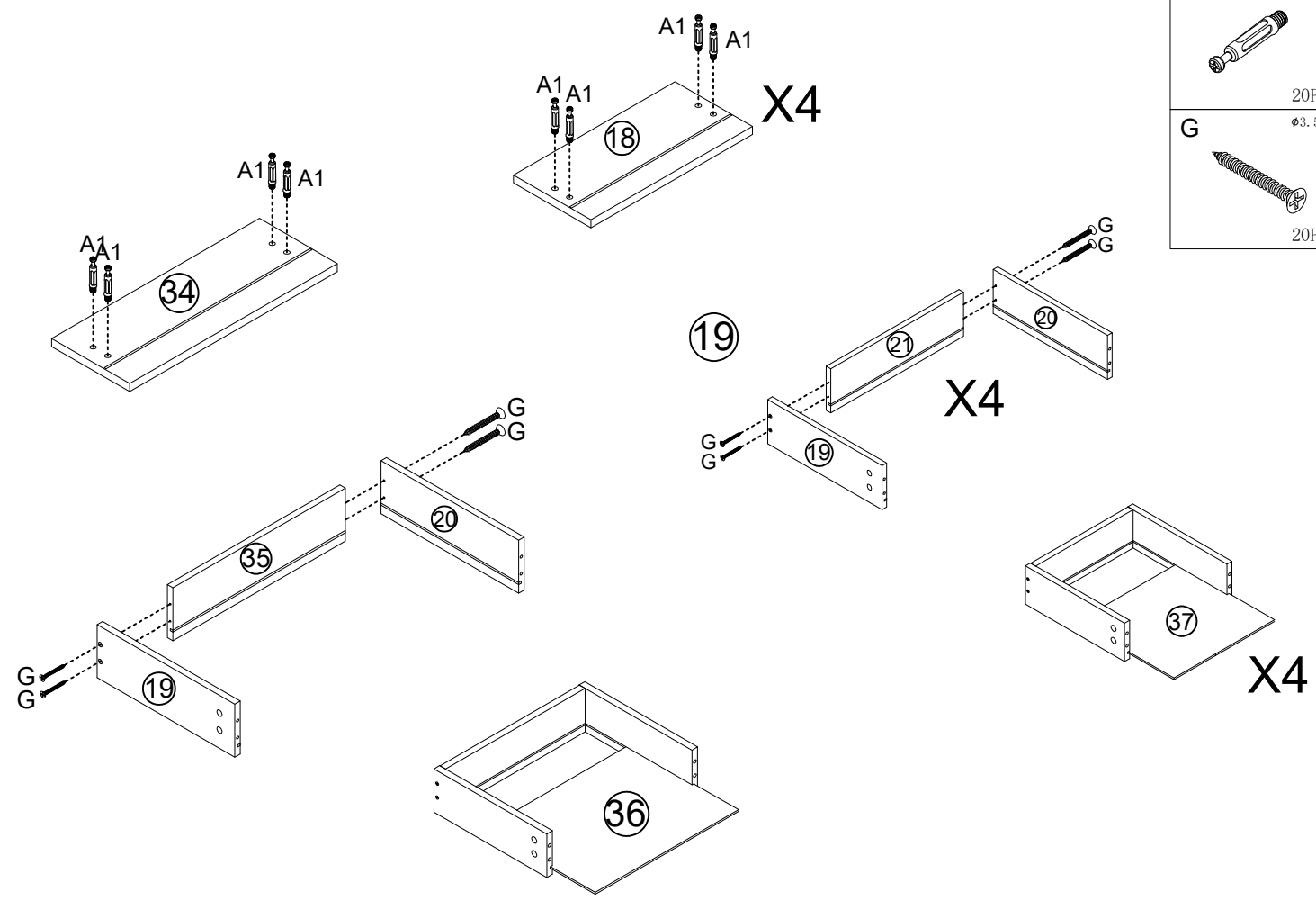

34

| | | |
|----|---|------------------|
| A1 |  | 20PCS |
| G |  | Ø3.5*35 20PCS |

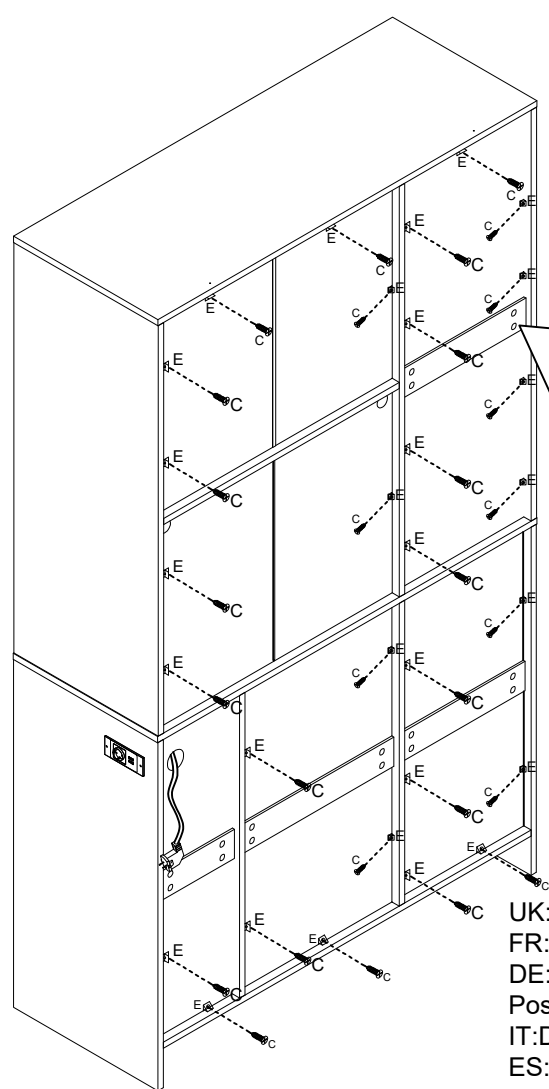
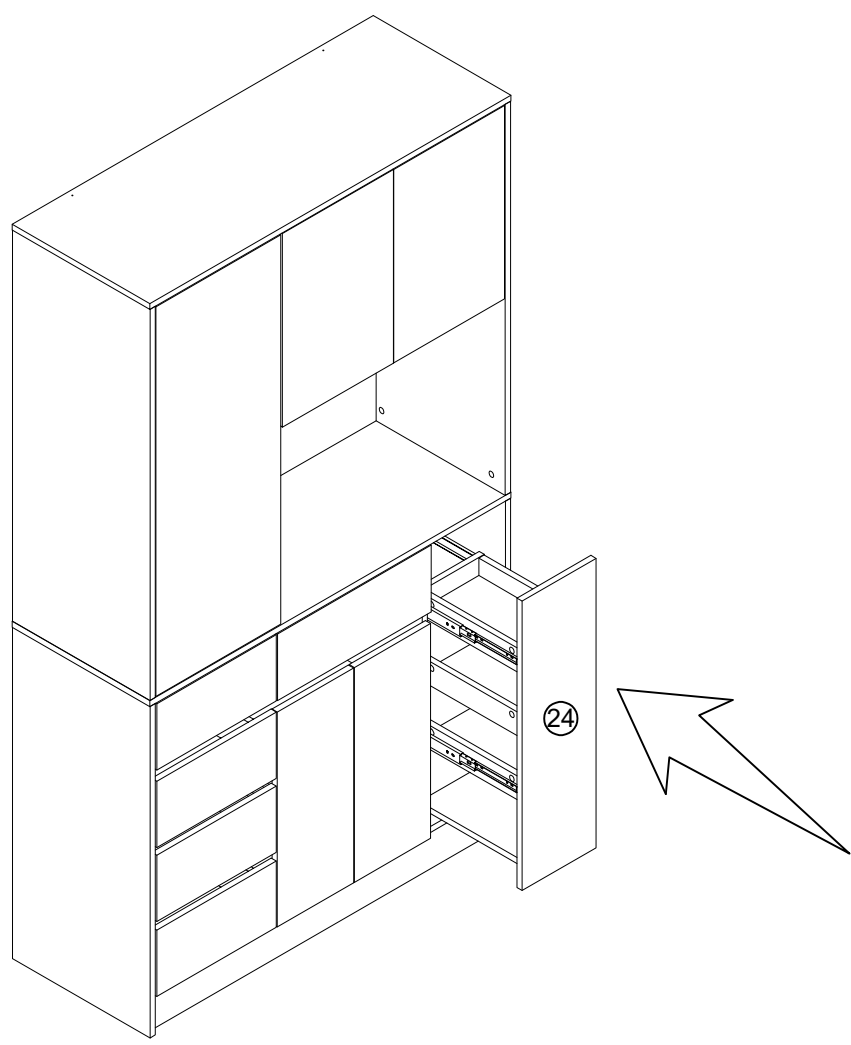





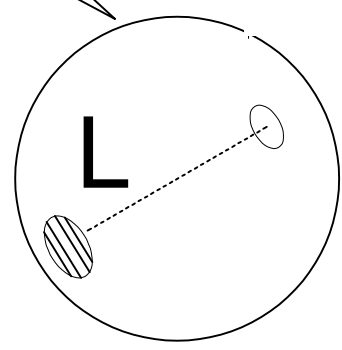

| | | |
|----------|---|---------|
| C |  | Ø3.5*14 |
| | | 30PCS |
| L |  | |
| | | 30PCS |
| P |  | |
| | | 30PCS |



UK: After installing the product, stick the number L on the perforated position.
 FR: Une fois le produit installé, collez le numéro L à l'endroit où il ya des trous.
 DE: Nach der Installation des Produkts kleben Sie die Nummer L auf die perforierte Position.
 IT: Dopo l'installazione del prodotto, fissare il numero L sulla posizione perforata.
 ES: Después de instalar el producto, pegue el número L en la posición perforada.

①

-  *2
-  *2
-  *2
-  *2
- 1SET

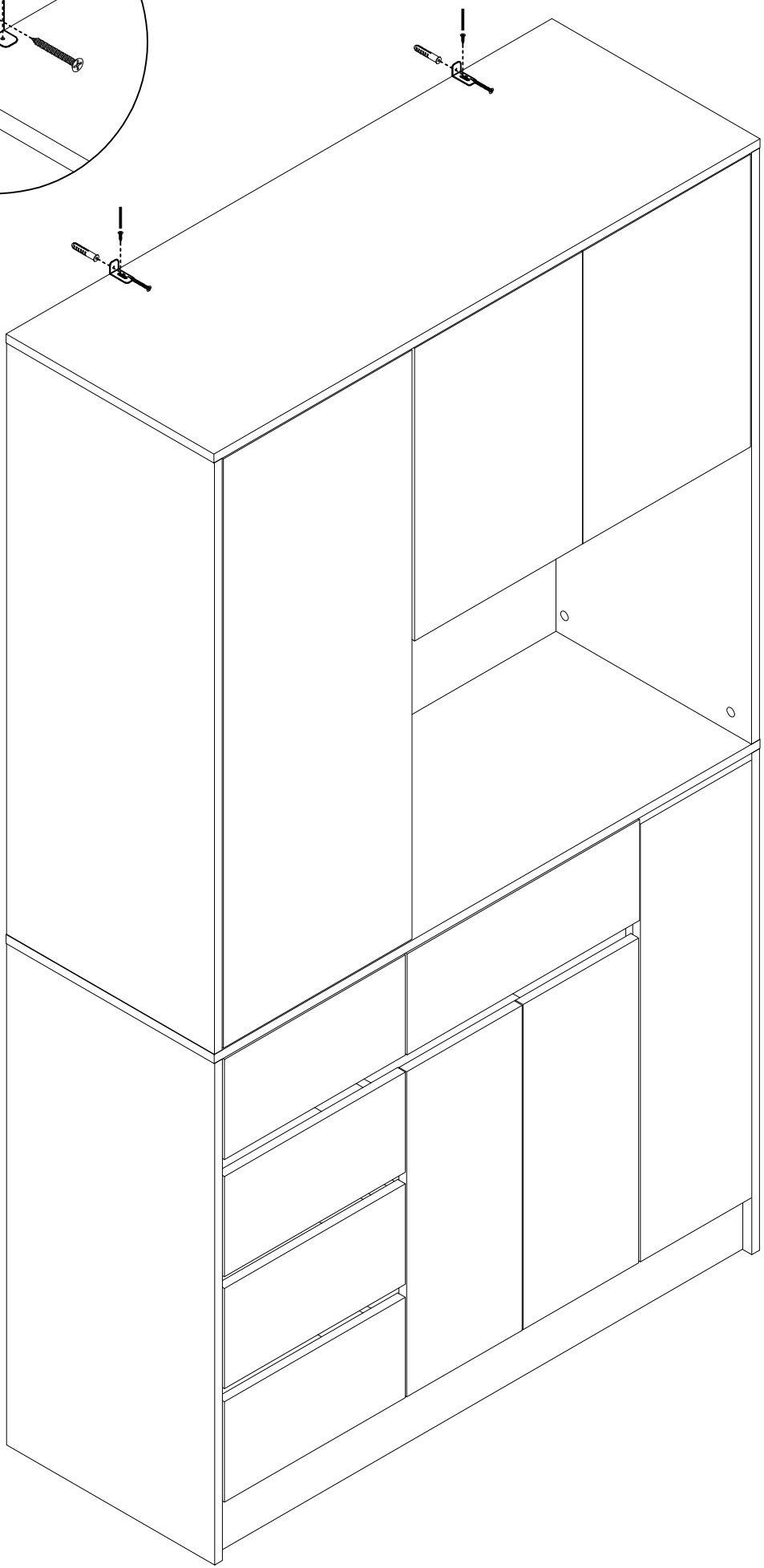
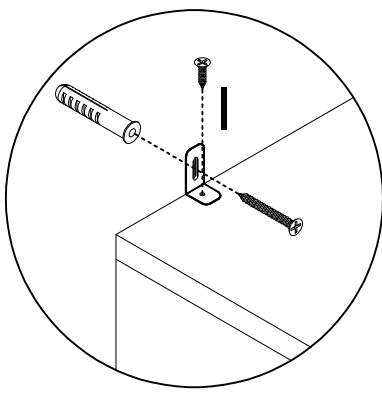

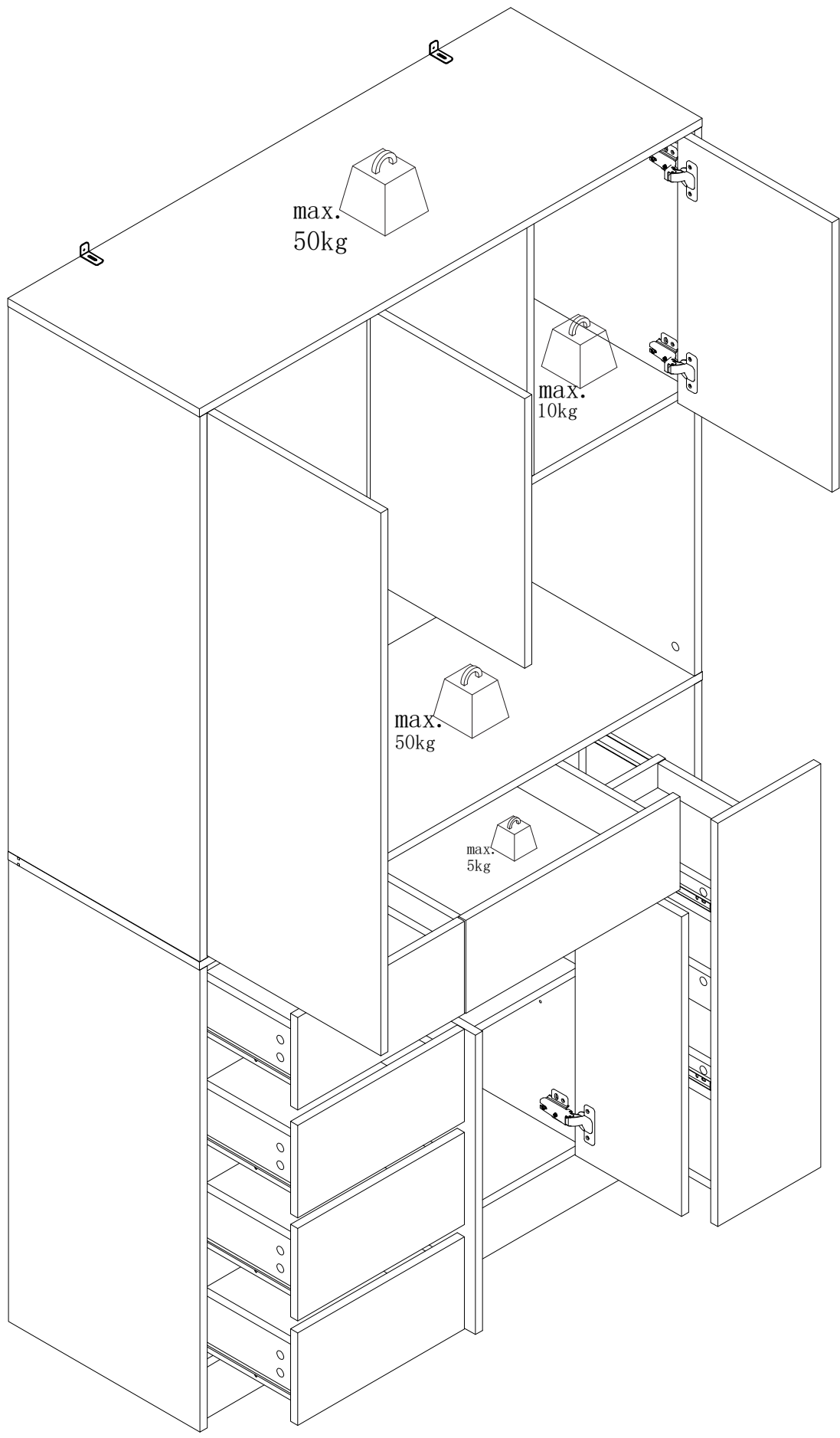

APP-PROGRAMMANWENDUNG

Klicken, um
Lampenliste
anzuzeigen
Farbrad
wechseln



Klicken für
Einstellungsansicht

Farbe anpassen

Farbanpassung
per Quadrat-
Symbol

Schnittstelle
durch Klicken
wechseln

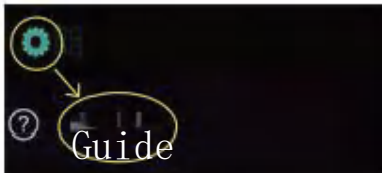

HINWEIS:

Detaillierte Anleitung im
Menü "Guide"

PRODUKTPARAMETER

- Bluetooth: BLEVA 2
- Eingangsspannung: 4.5~26V
- Betriebstemperatur: -25~75 °C
- Abmessungen: 43×22×11 mm
- Gewicht: 30g
- Max. Leistung: 144W (24V)

VERBINDUNGSSCHRITTE

- ① LED-Farbstreifen & Controller verbinden, Controller einschalten
- ② QR-Code scannen zum App-Download:



- ③ App starten, Controller suchen & verbinden
- ④ Bluetooth-Drahtlossteuerung genießen

PRODUKTMERKMALE

- Direkte Handy-Steuerung (20m Reichweite)
- Automatische Verbindung in 5 Sekunden
- Musikrhythmus-Synchronisation
- Gruppensteuerung
- Helligkeits-/Geschwindigkeitsregelung
- Unterstützt bis 10m RGB(W)-Streifen
- Automatische Sprachumschaltung (DE/EN)

ANIMATIONSEFFEKTE

- Farbverläufe
- Einfarbige/ Zweifarbige Gradienten
- Monochrome/Bunte Blinkeffekte
- Farbspringen
- Musikresponsive Effekte

APP PROGRAM USAGE

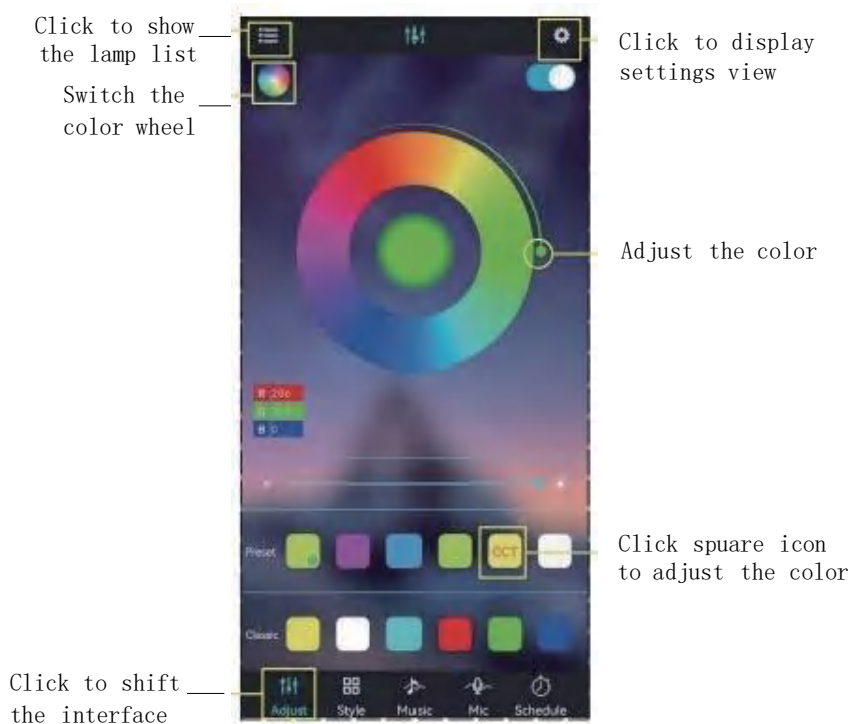

- Scan two-dimensional code download APP
- ①Connect LED color strip and controller, power on controller
 - ②Scan two-dimensional code download APP:



- ③Start APP, search and connect controller
- ④Enjoy the Bluetooth wireless control experience



Notes:
detailed operating instructions,
enter the menu "Guide":

Product Paramters:

- Bluetooth:BLEV4.2
- Input Voltage:4.5~26V
- Working Temp:-25~75°C
- Size:43*22*11mm
- Weight:30g
- Max Power:144W (24V)

LED mobile phone Bluetooth controllerProduct Features

- LED Bluetooth controller is directly via mobilephone control remote distance can reach 20m without the need to setupeasy to connect open the software within 5 seconds you can automatically connect the controller
- Flow the rhythm of the music changes
- Group control
- Brightness, speed addition and subtraction
- Maximum can be 10 meters RGB(W) strip
- The software shows that the text is based onthe language of the mobile phone set up automatic transformation of Chinese and English

ANIMATION EFFECTS:

- Colorful gradient
- All kinds of monochrome, double color gradient
- All kinds of monochrome, double color, colorfull flashing
- Colorful jump
- Follow the thymhm of the music chagnes

APP-PROGRAMMANWENDUNG

Afficher la
liste des lampes
Farbrad
Changer la
Roue chromatique



Afficher les
paramètres

Ajuster la couleur

Cliquez sur l'icône
carrée pour ajuster
la couleur.

Changer d'
interface
par clic

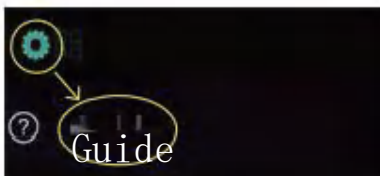

REMARQUE :

Guide détaillé dans le menu
"Guide"

CARACTÉRISTIQUES

- Bluetooth : BLEVA 2
- Tension d'entrée : 4.5~26V
- Température : -25~75° C
- Dimensions : 43×22×11 mm
- Poids : 30g
- Puissance max : 144W (24V)

ÉTAPES DE CONNEXION

- ① Connecter bande LED & contrôleur, allumer
- ② Scanner QR code pour télécharger l'app :



- ③ Lancer l'app, rechercher & connecter
- ④ Profiter du contrôle Bluetooth sans fil

FONCTIONNALITÉS

- Contrôle direct par smartphone (20m)
- Connexion automatique en 5 secondes
- Synchronisation musicale
- Contrôle de groupe
- Réglage luminosité/vitesse
- Prise en charge bandes ≤10m RGB(W)
- Basculement automatique FR/EN

EFFETS D'ANIMATION

- Dégradés de couleurs
- Dégradés uni/bicolores
- Clignotements mono/colorés
- Saut de couleurs
- Effets réactifs à la musique

UTILIZZO APP



PASSI CONNESSIONE

- ① Collega striscia LED & controller, accendi
- ② Scansiona QR code per scaricare APP:



- ③ Avvia APP, cerca & connetti controller
- ④ Goditi controllo wireless Bluetooth

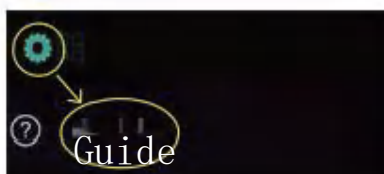

NOTA:

Guida completa nel menu "Guide"

SPECIFICHE:

- Bluetooth: BLEVA 2
- Tensione ingresso: 4.5~26V
- Temperatura: -25~75° C
- Dimensioni: 43×22×11 mm
- Peso: 30g
- Potenza max: 144W (24V)

CARATTERISTICHE

- Controllo diretto smartphone (20m)
- Connessione automatica in 5 secondi
- Sincronizzazione ritmo musicale
- Controllo di gruppo
- Regolazione luminosità/velocità
- Supporto strisce ≤10m RGB(W)
- Auto switch IT/EN

EFFETTI ANIMAZIONE:

- Sfumature colore
- Gradienti mono/bicolori
- Luci lampeggianti mono/colorate
- Salto colori
- Effetti reattivi alla musica

Shenzhen Promise Test Technology Co.,Ltd.
103, Building 1, Yibaolai Industrial City, Qiaotou Community, Fuhai
Street, Baoan District, Shenzhen, Guangdong, China.



Certificate of Compliance

Certificate No.: PRMS2412151EC

Applicant : Shenzhen xu xing technology co., LTD
Floor 3, building C, Huaze hi tech Industrial Park, Shiyan
street, Bao'an District, Shenzhen

Manufacturer : Shenzhen xu xing technology co., LTD
Floor 3, building C, Huaze hi tech Industrial Park, Shiyan
street, Bao'an District, Shenzhen

Trade Mark : /

Product : Colorful light strip

Model(s) : XX5050RGB-60D
XX5050RGB-30D, XX5050RGB-72D, XX5050RGB-96D,
XX5050RGB-120D, XX2835-120D, XX2835-60D,
XX2835-150D, XX2835-240D, XX2835-W, Y-120D,
XX2835-W, Y-60D, XX2025-120D

Test Standard : EN IEC 55015:2019+A11:2020
EN IEC 61000-3-2:2019 + A1:2021 + A2:2024
EN 61000-3-3:2013 + A1:2019 + A2:2021
EN IEC 61547:2023

The EUT described above has been tested by us with the listed standards and found in compliance with the council EMC directive 2014/30/EU. It is possible to use CE marking to demonstrate the compliance with this EMC Directive. It is only valid in connection with the test report number: PRMS2412151ER.



Kind. Yang

Manager
Dec. 6, 2024

This Certificate of Conformity is based on single evaluation of the submitted sample(s) of the above mentioned product. It does not imply an assessment of the whole product and relevant . Directives have to be observed.

+86-0755-23319501

info@pnms-test.com

www.pnms-test.com



CERTIFICATE

Certification No.
ATSE25050970618

Report No.
ATSE250509711



DECLARATION OF CONFORMITY

This Verification of Compliance is hereby issued to the product designated below

Applicant : Shenzhen GEAO Technology Co.,Ltd.
Address : 13th Floor, Building 4A, Huaqiang Creative Industry
Park,Guangming Street, Guangming District, Shenzhen,
Guangdong, China
Manufacturer : Shenzhen GEAO Technology Co.,Ltd.
Address : 13th Floor, Building 4A, Huaqiang Creative Industry
Park,Guangming Street, Guangming District, Shenzhen,
Guangdong, China
Product : Furniture Power Distribution Unit
Model : GEO101T-050210, GEO101T-050210-A, GEO101T-050210-C,
GEO101T-050210-1, GEO101T-050210-A-1, GEO101T-050210-C-1,
GEO101T-050200, GEO101T-050200-C, GEO101T-050200-1,
GEO101T-050200-C-1, GEO201T-PD20W
Rating(s) : Input: 220-250Vac, 50/60Hz, 16A Max
Output: Refer to the test report for details
Tested according to : EN 55032:2015+A11:2020+A1:2020
EN 55035:2017+A11:2020
EN IEC 61000-3-2:2019+A1:2021+A2:2024
EN 61000-3-3:2013+A1:2019+A2:2021

This certificate of conformity is based on evaluation of a sample of the above mentioned product. Technical report and documentation are at the licence Holder's disposal. This is to certify that the tested sample is in conformity with all revision of Annex I of Council Directive 2014/30/EU, referred to as the EMC. This certificate does not imply assessment of the series-production of the product . The holder of the certificate is authorized to use this certificate in Connection with the EC declaration of conformity according to Annex IV of the Directive.

ATS Electronic Technology Co., Ltd.

Tel : 86-769-3897 5958 e-mail: ats@dgats.com
Fax: 86-769-3897 5968 http://www.dgats.com

Date of issue: 2025-06-10



 The CE Marking may be used if all relevant and effective EC Directives are complied with. 