

Bed Frame

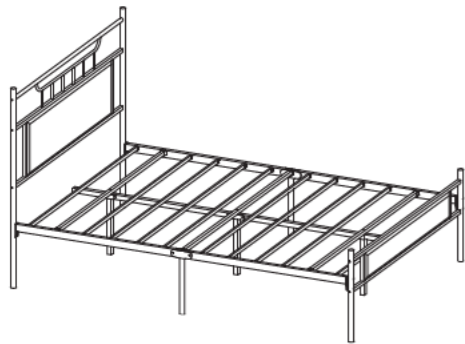

Bettrahmen

## CAUTION!



## ACHTUNG!



## ATTENTION !



## CAUTELA!



## PRECAUCIÓN !



## Step 7

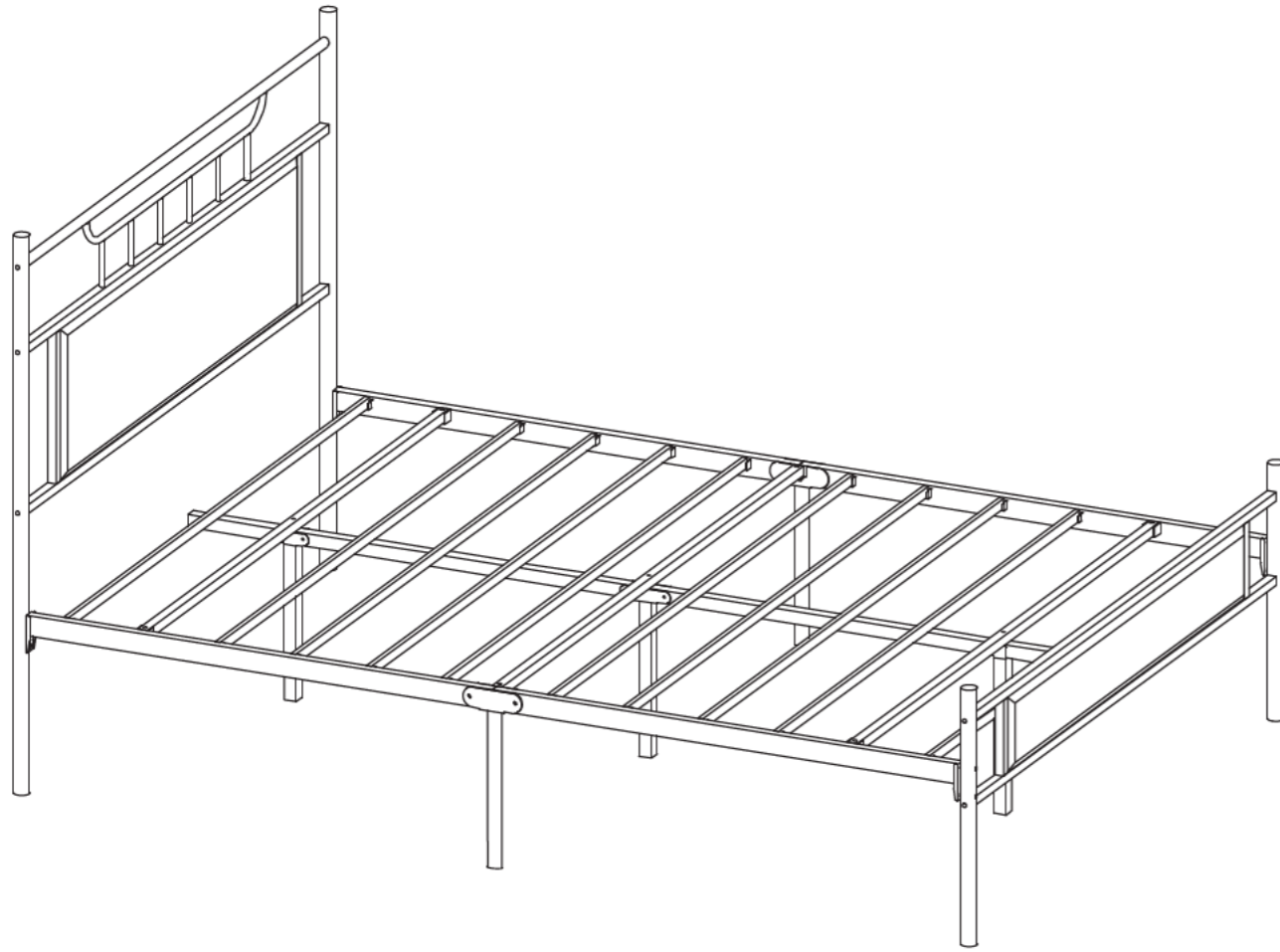

- Note: Now remember to double check all screws are properly fastened.
- ★ Hinweis: Vergessen Sie jetzt nicht, zu überprüfen, ob alle Schrauben richtig angezogen sind.
- ▲ Remarque : N'oubliez pas de vérifier que toutes les vis sont bien serrées.
- Nota: Ora ricordati di ricontrollare che tutte le viti siano correttamente fissate.
- ✿ Nota: Ahora recuerde volver a verificar que todos los tornillos estén correctamente apretados.

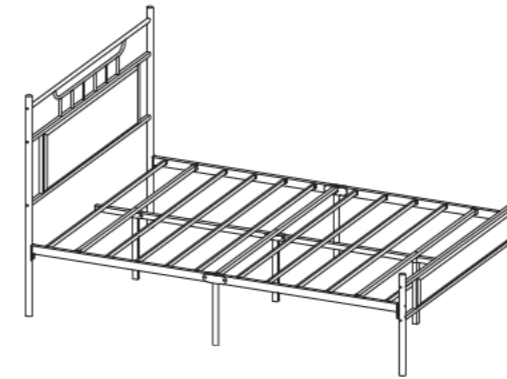

Cadre de lit

Step 6

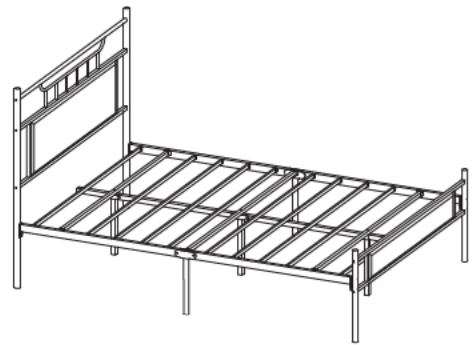

Telaio del letto

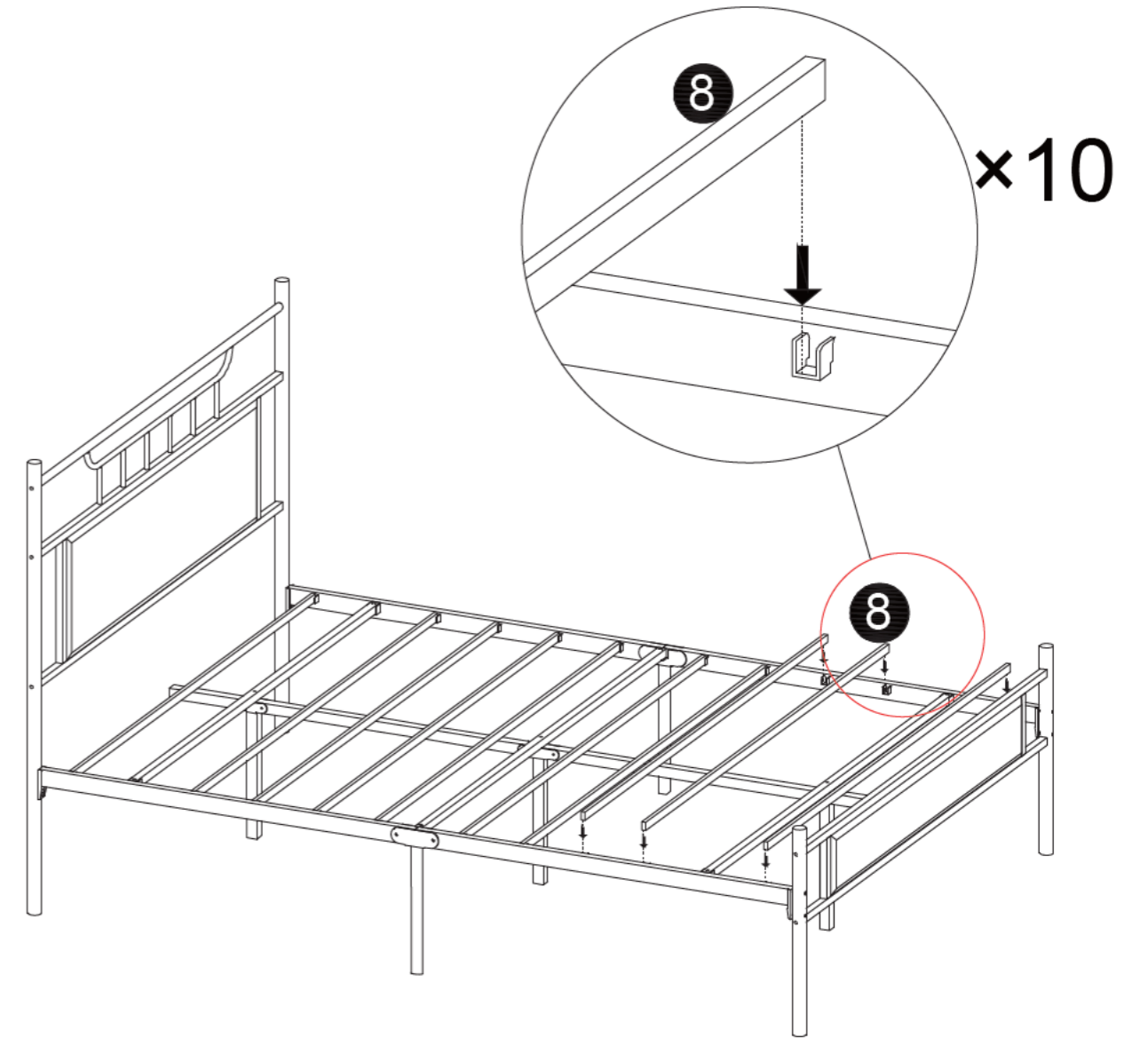

# Step 5

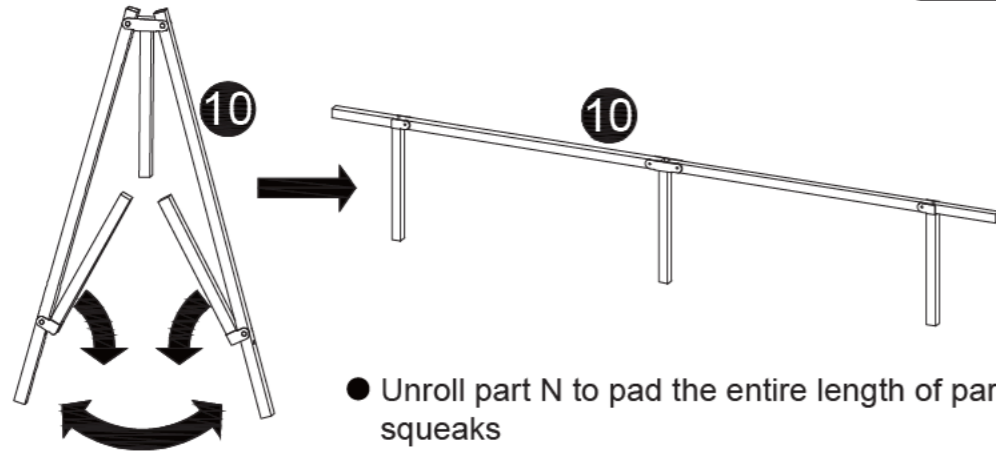
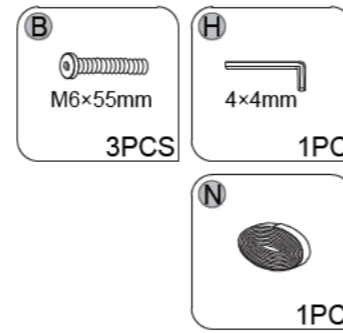

- Unroll part N to pad the entire length of part 10 to eliminate squeaks
- ★ Rollen Sie Bauteil N aus, um die gesamte Länge von Bauteil 10 zu polstern und somit Quietschgeräusche zu beseitigen.
- ▲ Dérouler la pièce N pour rembourrer la longueur afin d'éliminer les grincements.
- Srotolare la parte N per imbottire tutta la lunghezza della parte 10 per eliminare i cigolii
- Desenrolle la parte N para acolchar toda la longitud de la parte 10 para eliminar chirridos

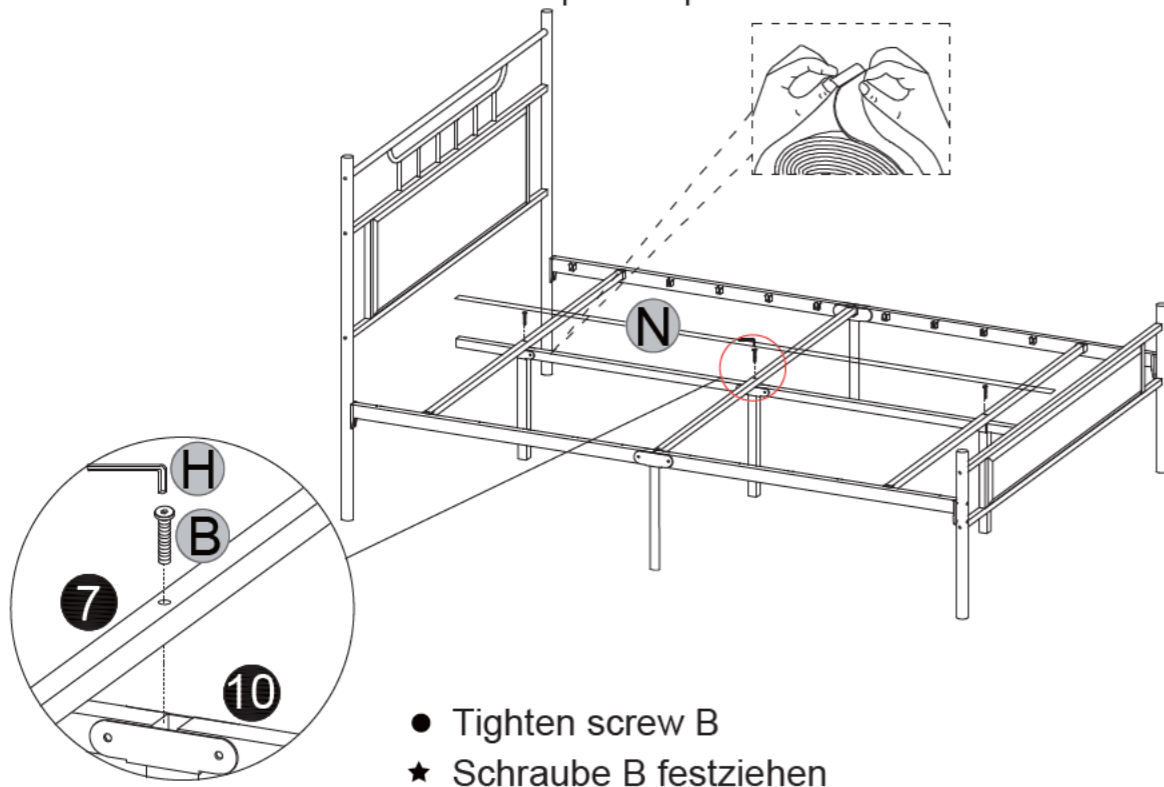

- Tighten screw B
- ★ Schraube B festziehen
- ▲ Serrer la vis B.
- Stringere la vite B
- Apretar el tornillo B

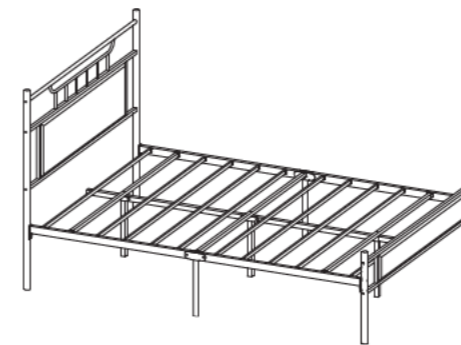

Marco de la cama

● #Number System

Follow the marked steps for the easiest assembling process

step 1 step 2 step 3 step 4...

★ #Zahlensystem

Folgen Sie den markierten Schritten für den Zusammenbau auf einfachste Weise

Schritt 1 Schritt 2 Schritt 3 Schritt 4 ...

▲ Système de numération

Suivez les étapes indiquées pour faciliter le processus de montage :

étape 1, étape 2, étape 3, étape 4, etc.

■ #Numero del Passo

Seguire i passaggi contrassegnati per un processo di assemblaggio più semplice

passo 1 passo 2 passo 3 passo 4...

✱ #Número de Paso

Siga los pasos marcados para el proceso de montaje más sencillo

paso 1 paso 2 paso 3 paso 4...

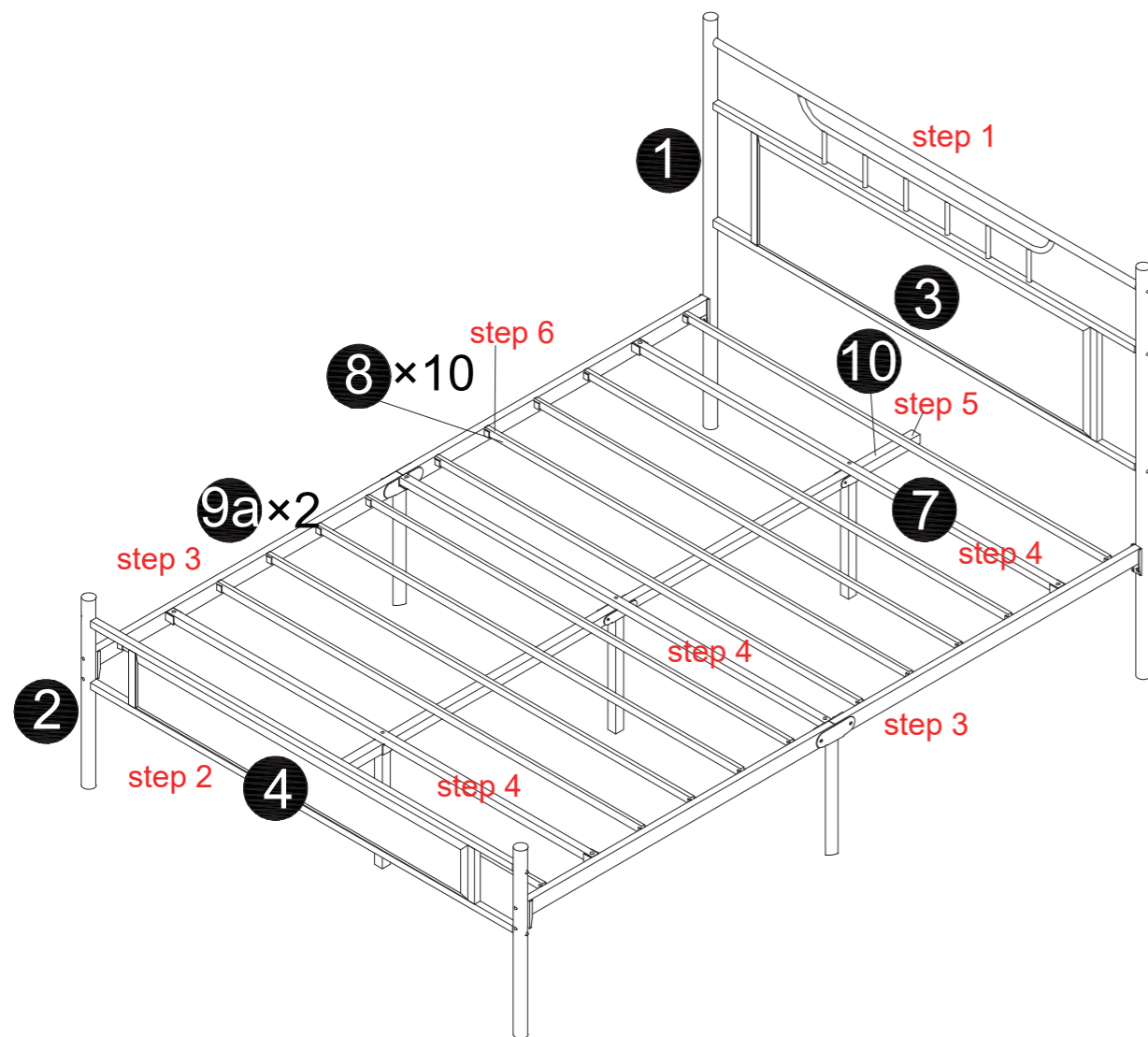

## Step 4

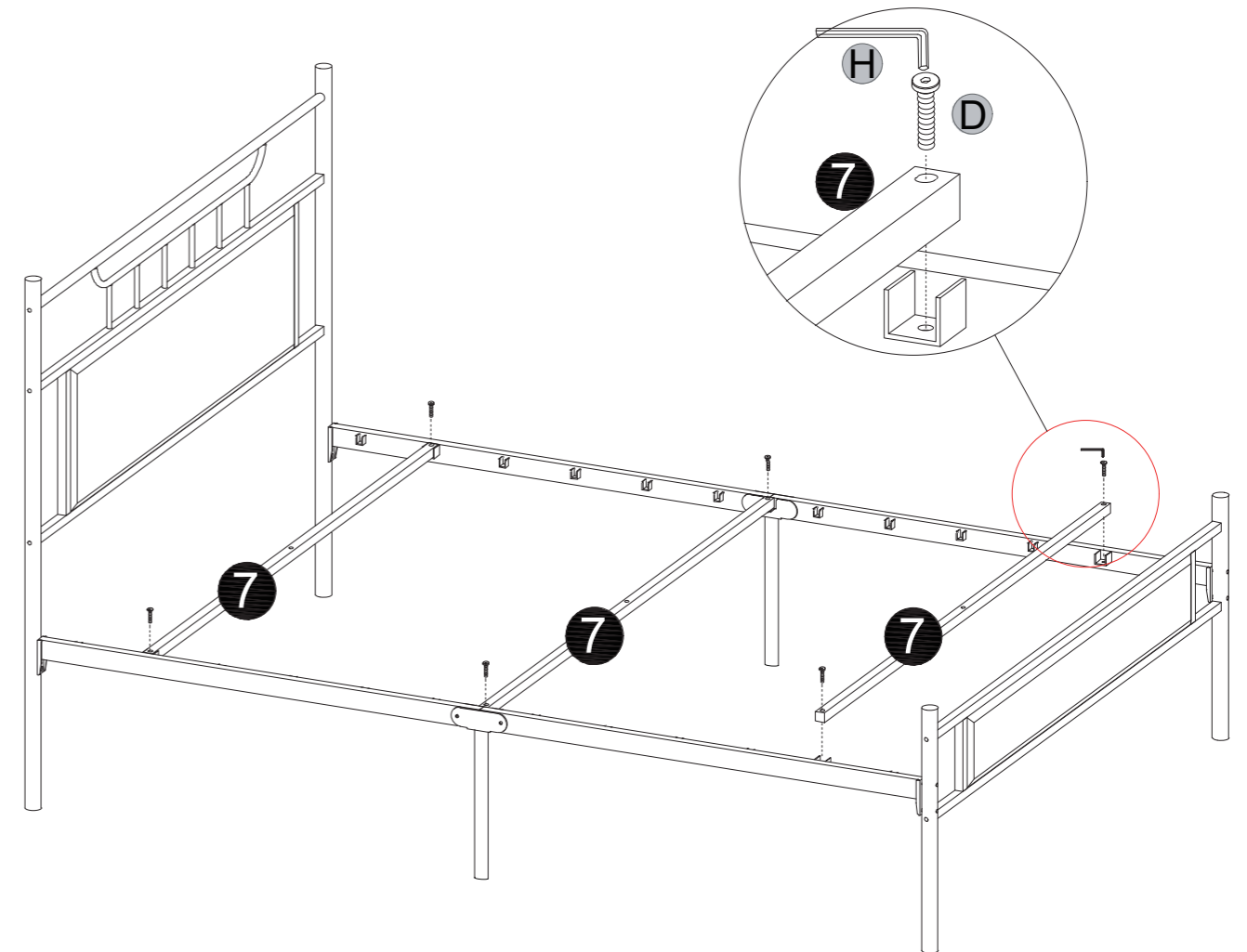
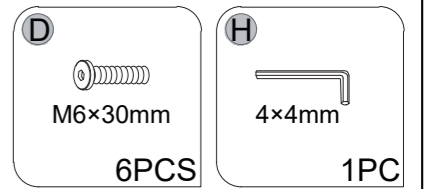

## Step 2

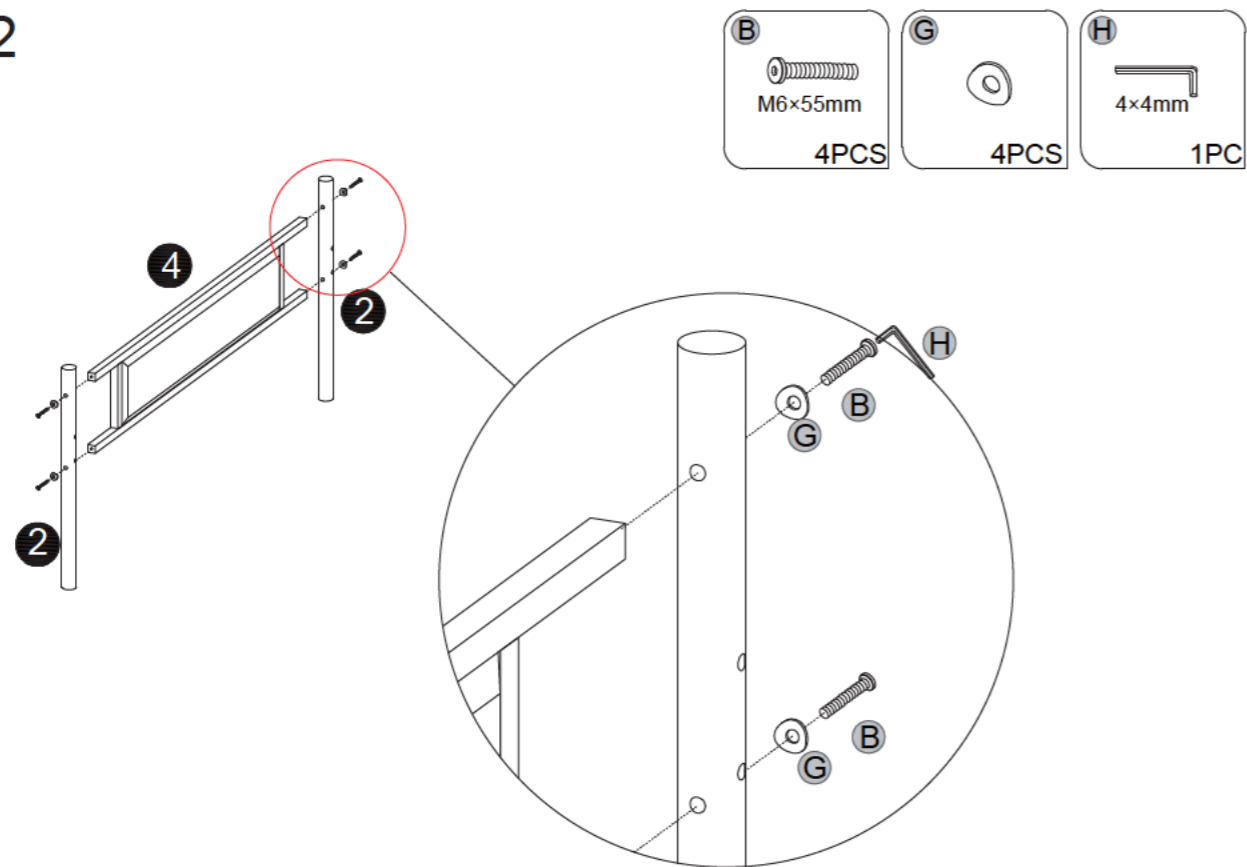

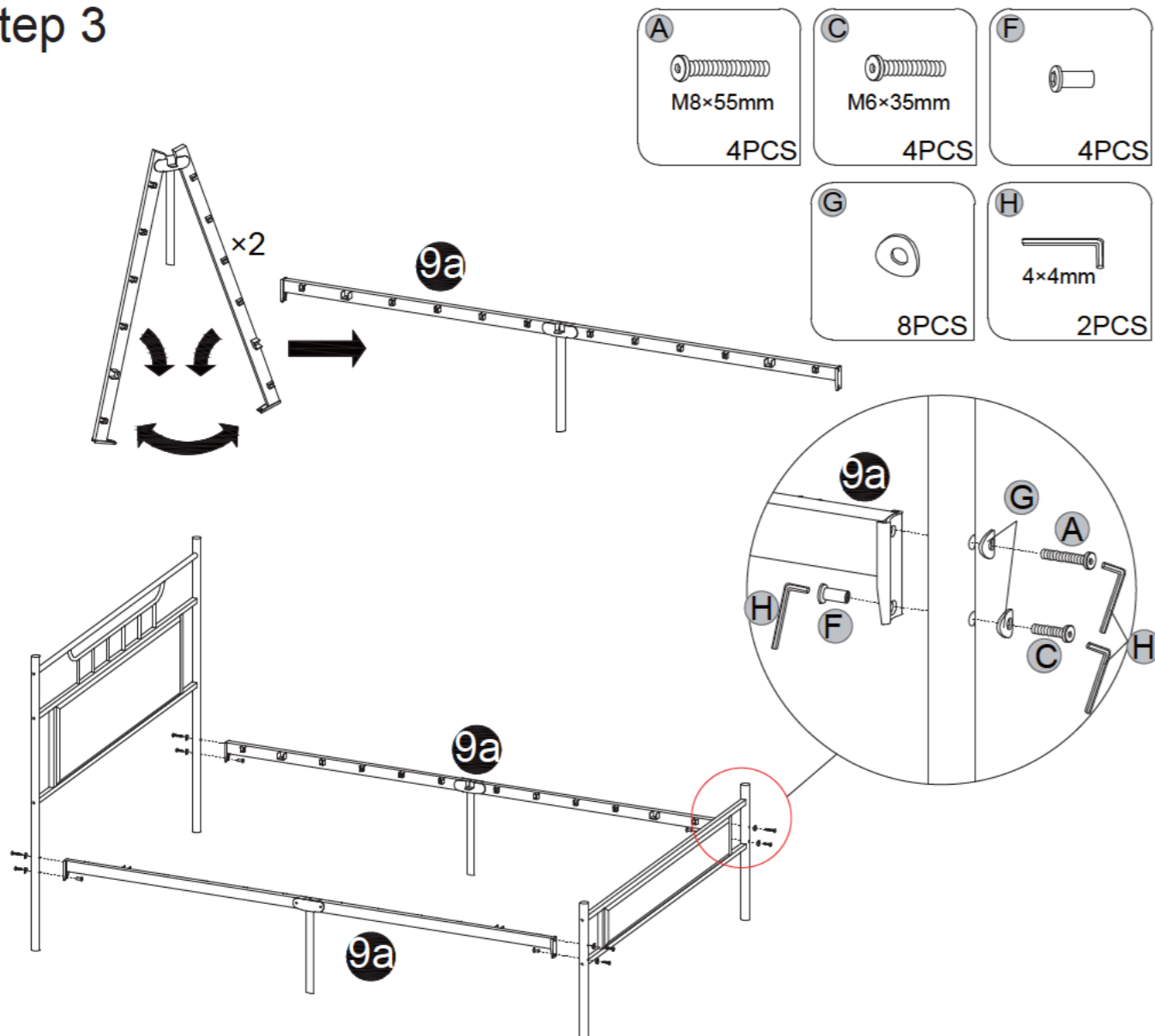

## Step 3

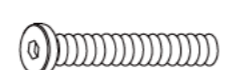
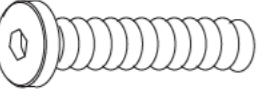
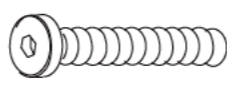

## Components / Bauteile / Componenti / Componentes /

<b>1</b>		2pcs	<b>2</b>		2pcs
<b>3</b>		1pc	<b>4</b>		1pc
<b>7</b>		3pcs	<b>8</b>		10pcs
<b>9a</b>		2pcs	<b>10</b>		1pc

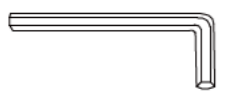
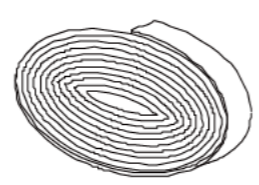
<b>A</b>	 M8x55mm	4pcs	<b>B</b>	 M6x55mm	13pcs
<b>C</b>	 M6x35mm	4pcs	<b>D</b>	 M6x30mm	6pcs
<b>F</b>		4pcs	<b>G</b>		18pcs
<b>H</b>	 4x4 mm	2pcs	<b>N</b>		1pc

## Step 1

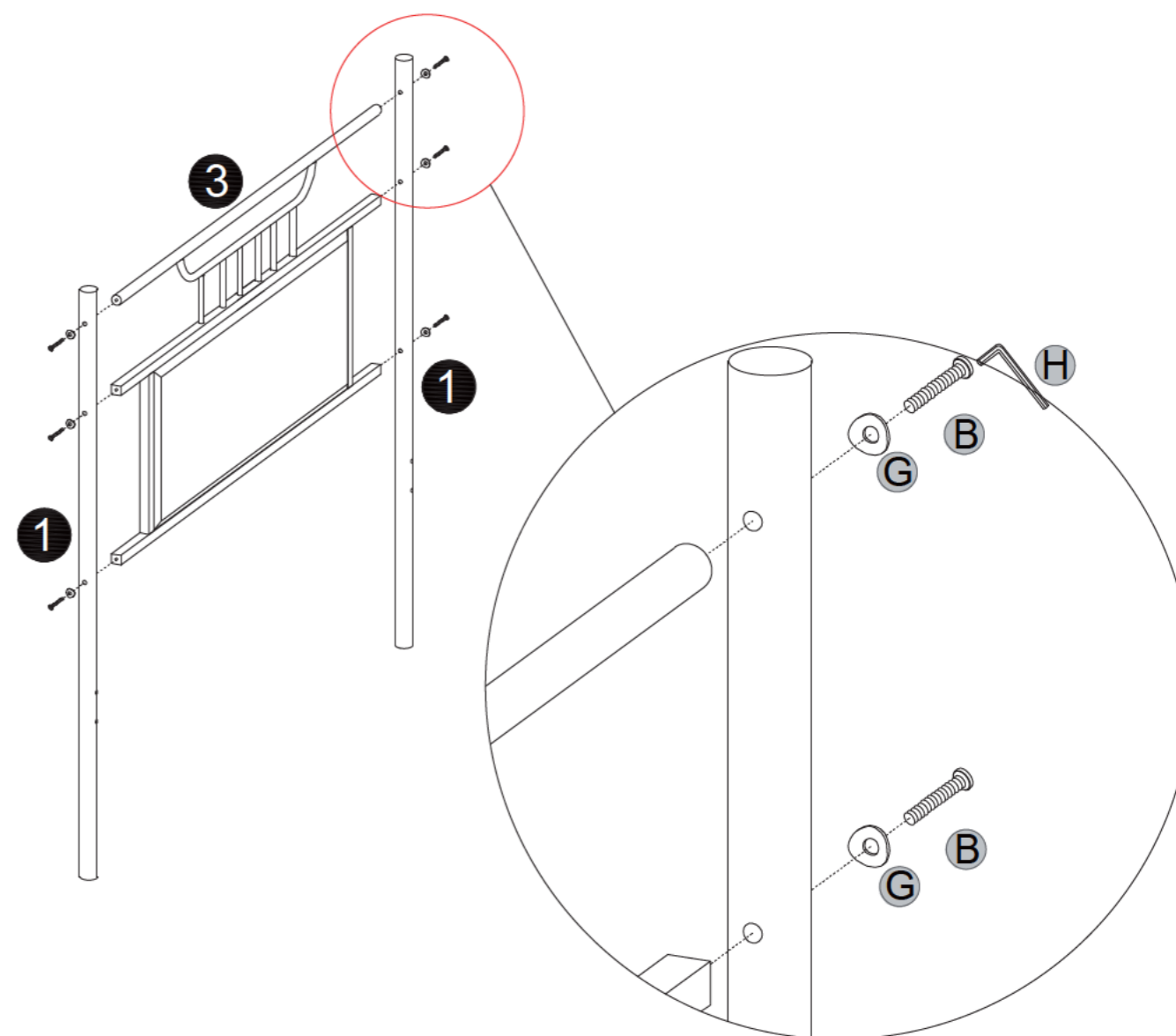
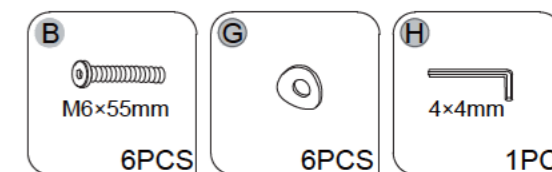

- Note: For easy setup, do not tighten screws during the installation process.
- ★ Hinweis: Um die Installation zu erleichtern, ziehen Sie die Schrauben während des Installationsprozesses nicht vollständig fest.
- ▲ Remarque : Pour faciliter le montage, ne serrez pas les vis à fond pendant l'installation.
- Nota: Per una facile installazione, non serrare le viti durante il processo di installazione.
- ☀ Nota: Para una fácil instalación, no apriete los tornillos durante el proceso de instalación.