

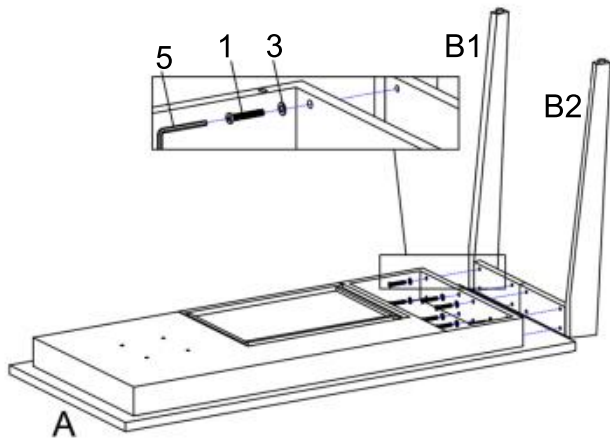







THANK YOU FOR PURCHASING THIS QUALITY PRODUCT.  
 BE SURE TO CHECK ALL PACKING MATERIAL CAREFULLY FOR SMALL PARTS THAT MAY HAVE COME LOOSE INSIDE THE CARTON DURING SHIPMENT.

**STEP 1**

**PART LIST**

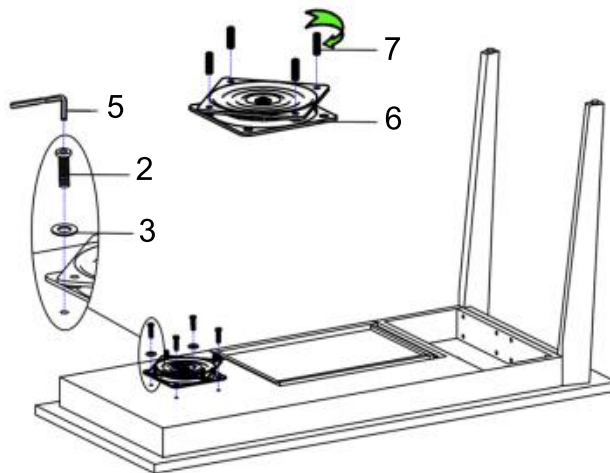
NO	DECS	SIZE (MM)	SKETCH	QTY
A	TOP	1400*600*105		1PC
B1	DESK LEG-1	279*120*754		1PC
B2	DESK LEG-2	279*120*754		1PC
C	BOTTOM CABINET	1080*400*544		1PC
D	BOTTOM BASE	155*25*80		4PCS

**STEP 2**

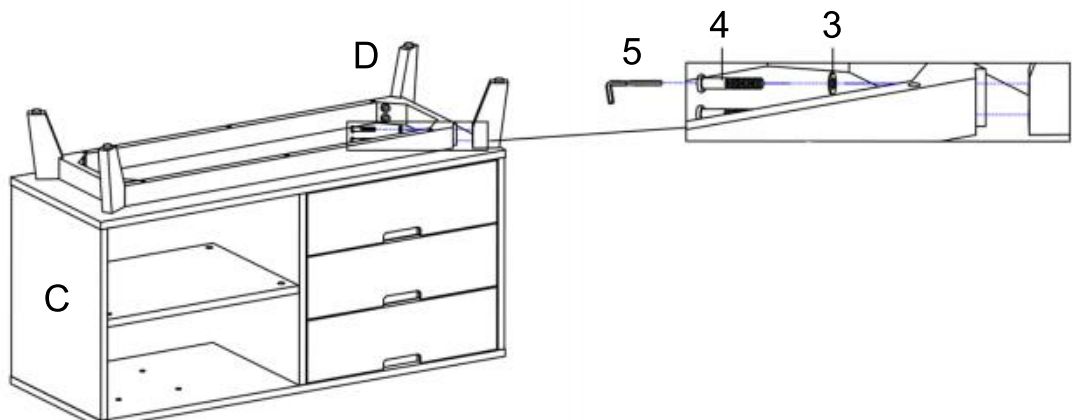
**HARDWARE LIST**

NO	DECS	SIZE (MM)	SKETCH	QTY
1	SCREW-1	M8*40		8PCS
2	SCREW-2	M8*25		4PCS
3	FLAT WASHER	Φ17*2*Φ8		24PCS
4	SCREW-3	M8*65		8PCS
5	ALLEN KEY	5#		1PC
6	SWIVEL			1PC
7	LONG BOLT	M8*35		4PCS
8	NUT	M8		4PCS
9	SPRING WASHER	Φ13*Φ8		4PCS
10	HEXAGON SOCKET	14#		1PC

**STEP 3**

**MADE IN CHINA**

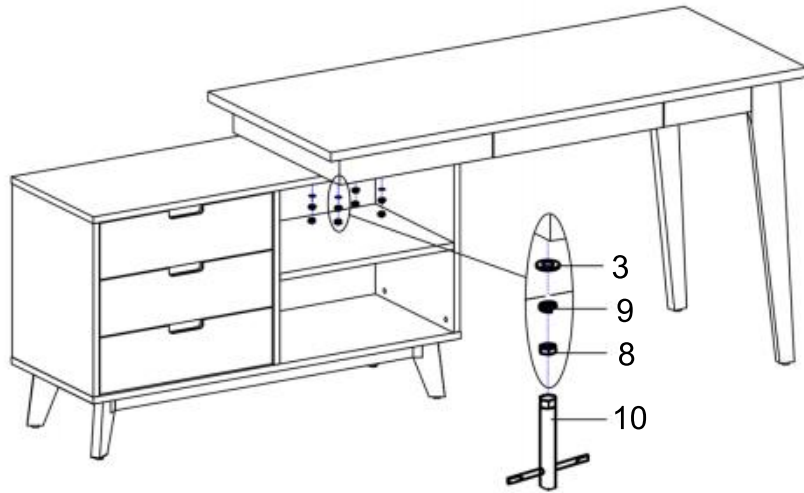

THANK YOU FOR PURCHASING THIS QUALITY PRODUCT.  
BE SURE TO CHECK ALL PACKING MATERIAL CAREFULLY FOR SMALL PARTS THAT MAY HAVE COME LOOSE INSIDE THE CARTON DURING SHIPMENT.

### STEP 4



### FINISHED

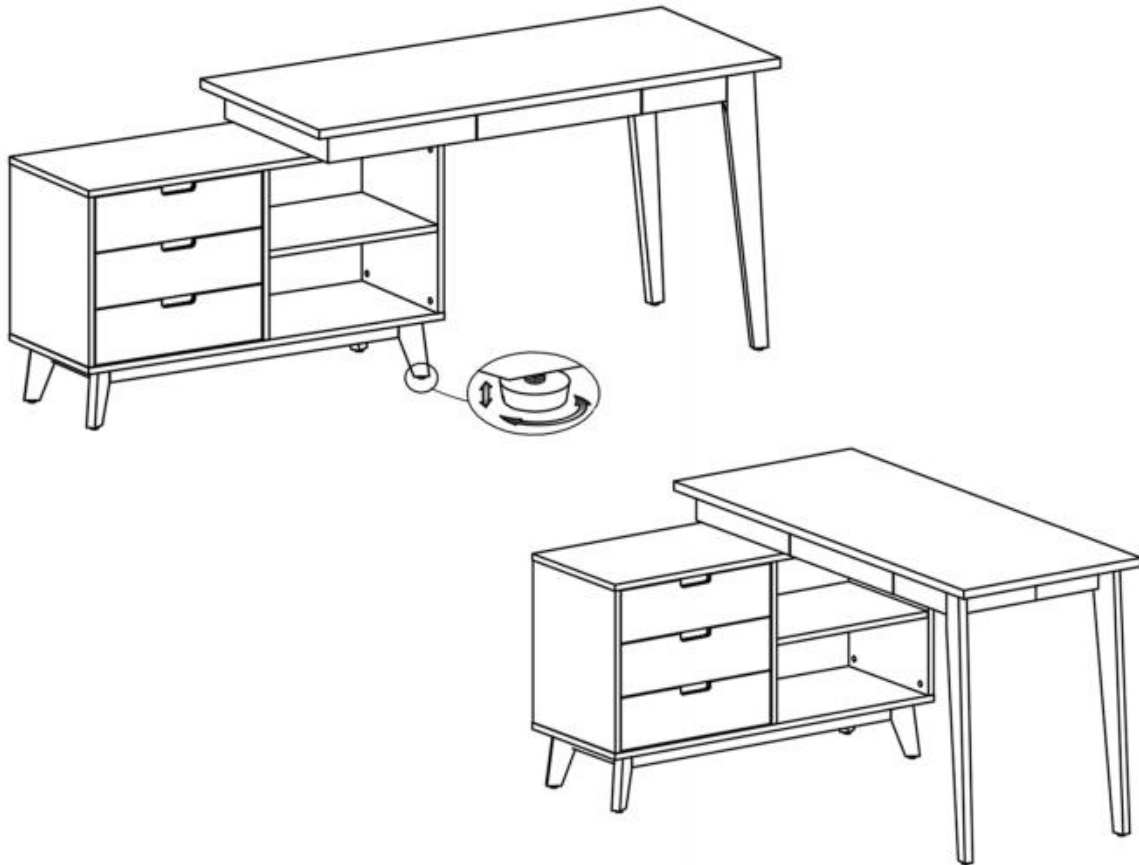

Adjustable glides are beneath, adjust it if needed.