

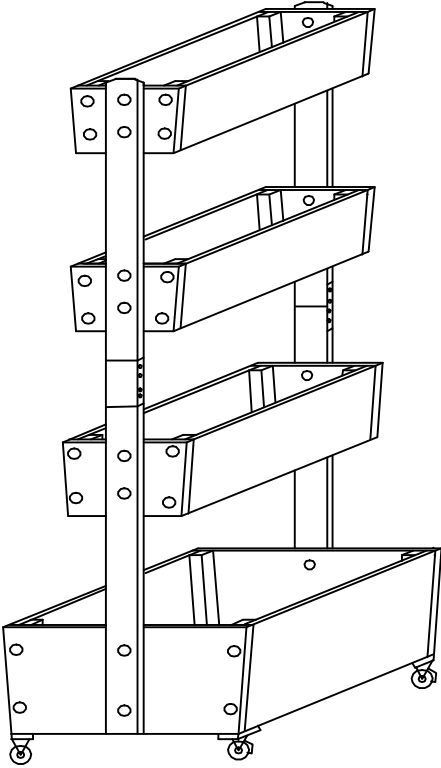

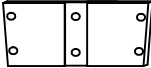







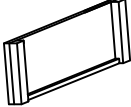
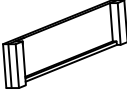
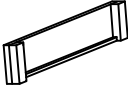

4 Tiers Wood Raised Planter box

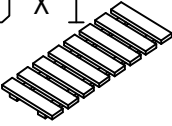
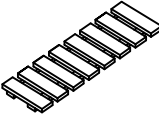
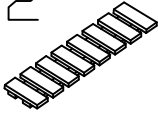

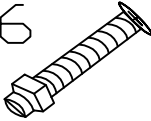
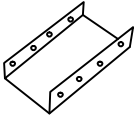
Parts And Hardwares List

<p>A x 2</p> 	<p>B x 2</p> 	<p>C x 4</p> 	<p>D x 2</p> 
<p>F x 2</p> 	<p>G x 2</p> 	<p>H x 4</p> 	<p>E x 2</p> 
<p>J x 1</p> 	<p>K x 1</p> 	<p>L x 2</p> 	
<p>M x 2</p> 	<p>N x 2</p> 	<p>O x 16</p>  <p>6*40</p>	
<p>S x 2</p> 		<p>P x 48</p>  <p>3.5*25</p>	
<p>Q x 16</p>  <p>3*35</p>		<p>R x 16</p>  <p>3*16</p>	

Please examine the contents of your package carefully before assembly. If any parts are missing, **DO NOT RETURN THIS PRODUCT OR CALL THE RETAILER.**

Step 1

Fasten part A x 2pcs to part F x 2pcs, using screw P x 8 pcs to secure them.

Fasten part I x 4pcs to the bottom four corner, using screw R x 16 pcs to secure them.

Then use screw Q x 16 pcs to secure wheels D x 2pcs and E x 2pcs.

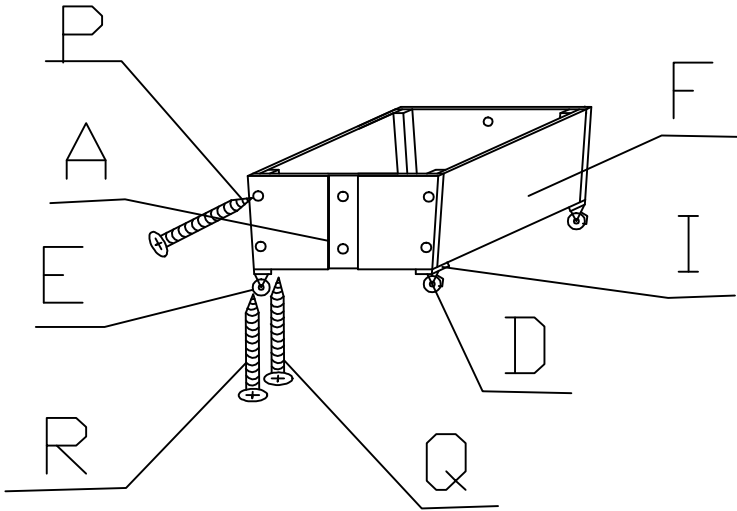

P 3.5*25=8pcs

Q 3*35=16PCS

R 3*16=16pcs

Step 2

Fasten part M x 2pcs to the two sides of the box (the one assembled after step 1), using screw O x 4 pcs to secure them.

Then put the part J into the bottom of the box.

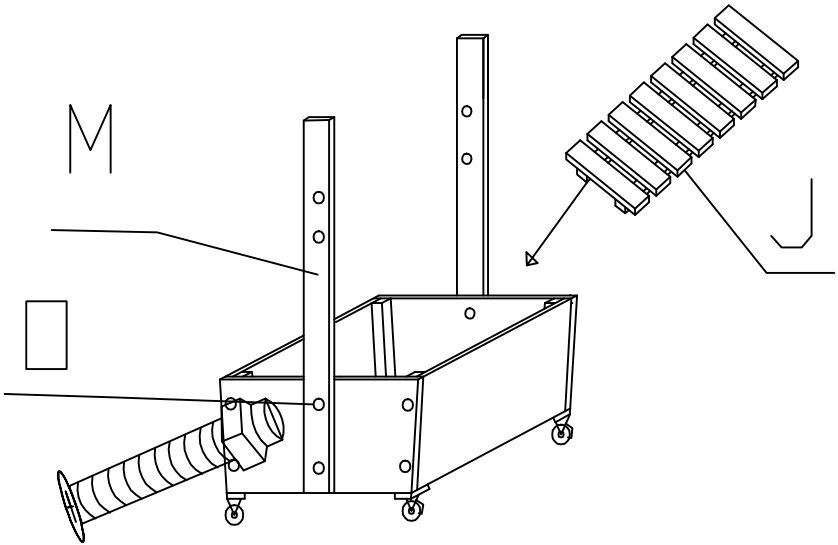

□ 6*40=4PCS

Step 3

Fasten part B x 2pcs to part G x 2pcs, using screw P x 8 pcs to secure them. Then use screw O x 4pcs to fasten the box to two sides post, and put the part K into the bottom of the box.

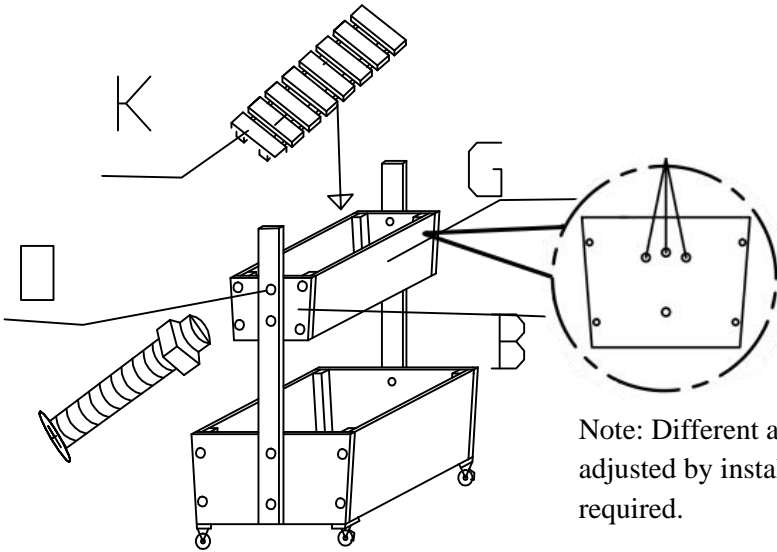

Note: Different angles can be adjusted by installing bolts as required.

□ 6*40=4PCS

P 3.5*25=8pcs

Step 4

Using part 3 to connect part N & M (two sides post), then use screw P x 16 pcs to secure them.

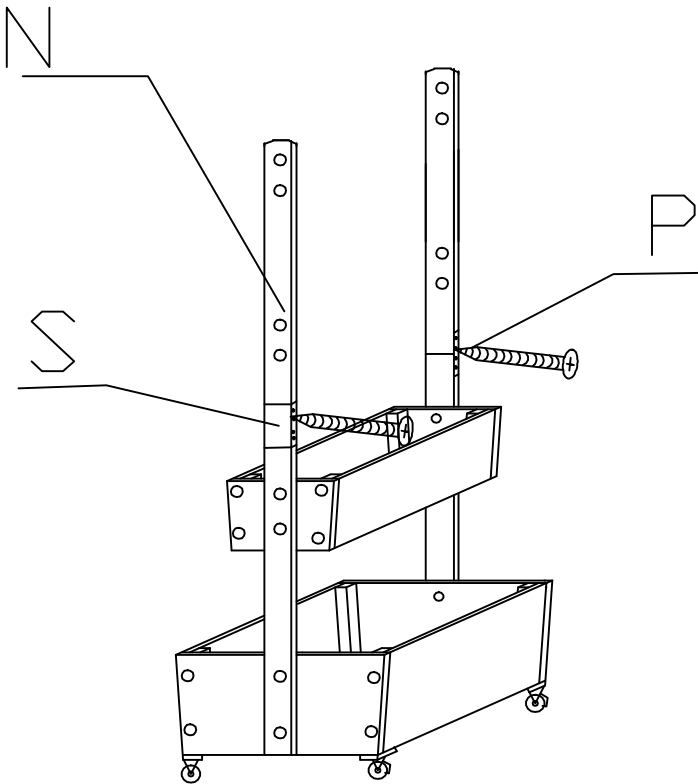

P 3.5*25 = 16 PCS

Step 5

Fasten part C x 2pcs to part H x 2pcs, using screw P x 8 pcs to secure them. Then use screw O x 4pcs to fasten the box to two sides post, and put the part L into the bottom of the box.

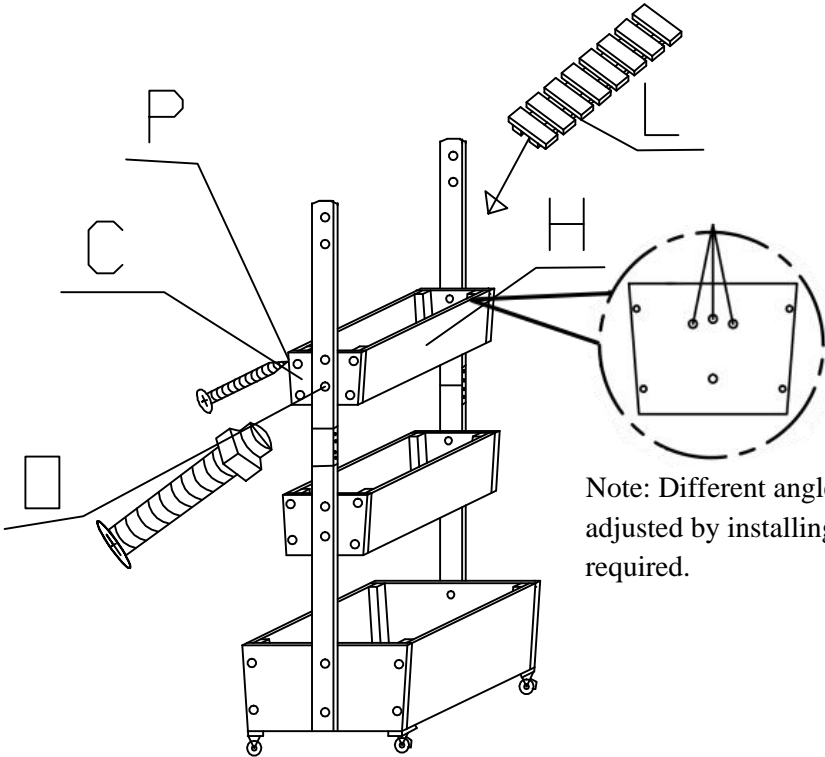

Note: Different angles can be adjusted by installing bolts as required.

□ 6*40=4PCS

P 3.5*25=8pcs

Step 6

Fasten part C x 2pcs to part H x 2pcs, using screw P x 8 pcs to secure them. Then use screw O x 4pcs to fasten the box to two sides post, and put the part L into the bottom of the box.

Friendly Reminder: Staple the black non-woven fabric liner onto the raised planter box can bean option to keep the raised bed well organized.

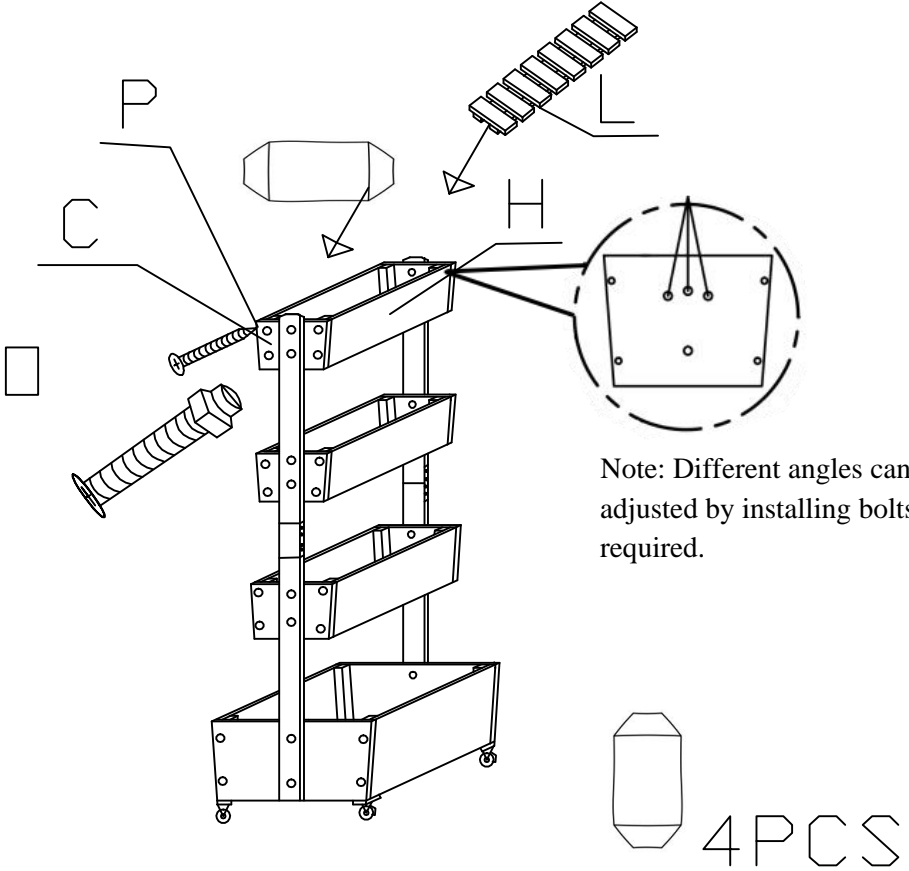

□ $6 * 40 = 4PCS$

P $3.5 * 25 = 8pcs$