

QUEEN BED
FULL BED
TWIN BED

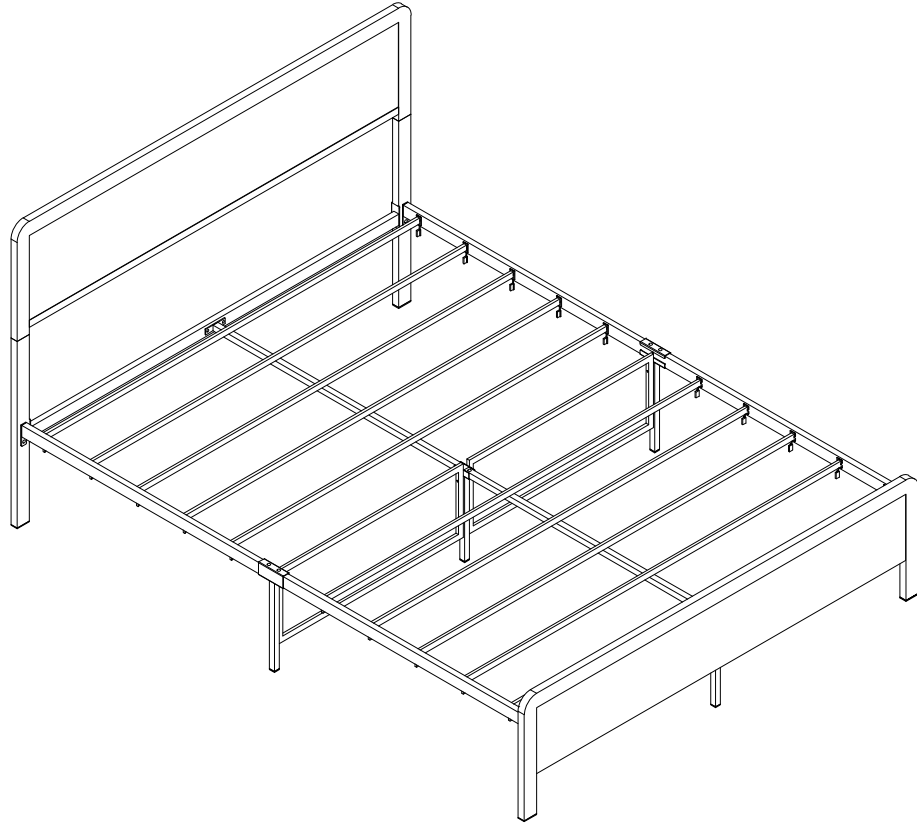

YOU NEED

1. Tools required

A Phillips head screw driver is required for the assembly of this product. (not included)
Electric tool should not be used to assemble this product.

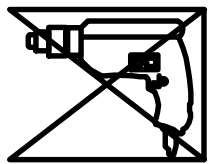
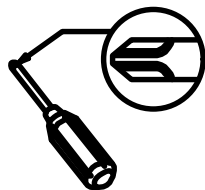

2. Two people are needed

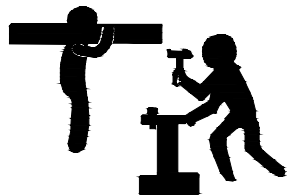

Tips!



1. Check all the components & screws are intact before assembling .
2. If you notice any pieces are missing or damaged please do not assemble and contact us immediately .
3. **Please send an email with you order number and issues, we will respond within 24 hours.**

IMPORTANT SAFETY INFORMATION

- Please carefully read the following instructions and caution warnings before assembling the product.
- Following this guide will ensure that you install, use and maintain the product properly.
- Please keep this installation and user manual/instructions for future reference in case you need to disassemble the product.
- Never allow children to climb onto the product. Ensure that you have special safety measures when children are around on their own.
- Be sure to check that all parts of the product are intact after you open the package.
- Do not assemble if you notice serious damage such as cracks or bends.
- During installation, please use work gloves for hand safety.
- Please assemble the unit on carpeted floor or the flat cardboard box to avoid scratching the surface or your floor while assembling on the floor.
- To assemble, please use the complimentary installation tools (Phillips screwdriver). Pay more attention to the direction of components at each steps.
- It is recommended that two people work together to assemble the product.

RETURN POLICY

- Please contact us directly within 30 days after receiving.
- Ensure the product is in a good condition with the original box and all original certificates of purchase, manuals, and accessories attached.

HOW TO MAINTAIN YOUR PRODUCT

- Check the screws of the product are not loose from regular use.
- Do not use sharp instruments, rubbing alcohol, corrosive chemicals, or abrasive cleaners to clean the item.

COMPONENTS ID Nr.

Part Nr.	Qty	Part Nr.	Qty	Part Nr.	Qty
A	1pc	B	1pc	C	1pc
D	1pc	E	1pc	F	1pc
G	1pcs	H	2pc	I	2pc
J	1pc	K	1pcs	M	1pcs
N	1pc	O	1pc	P	10pc

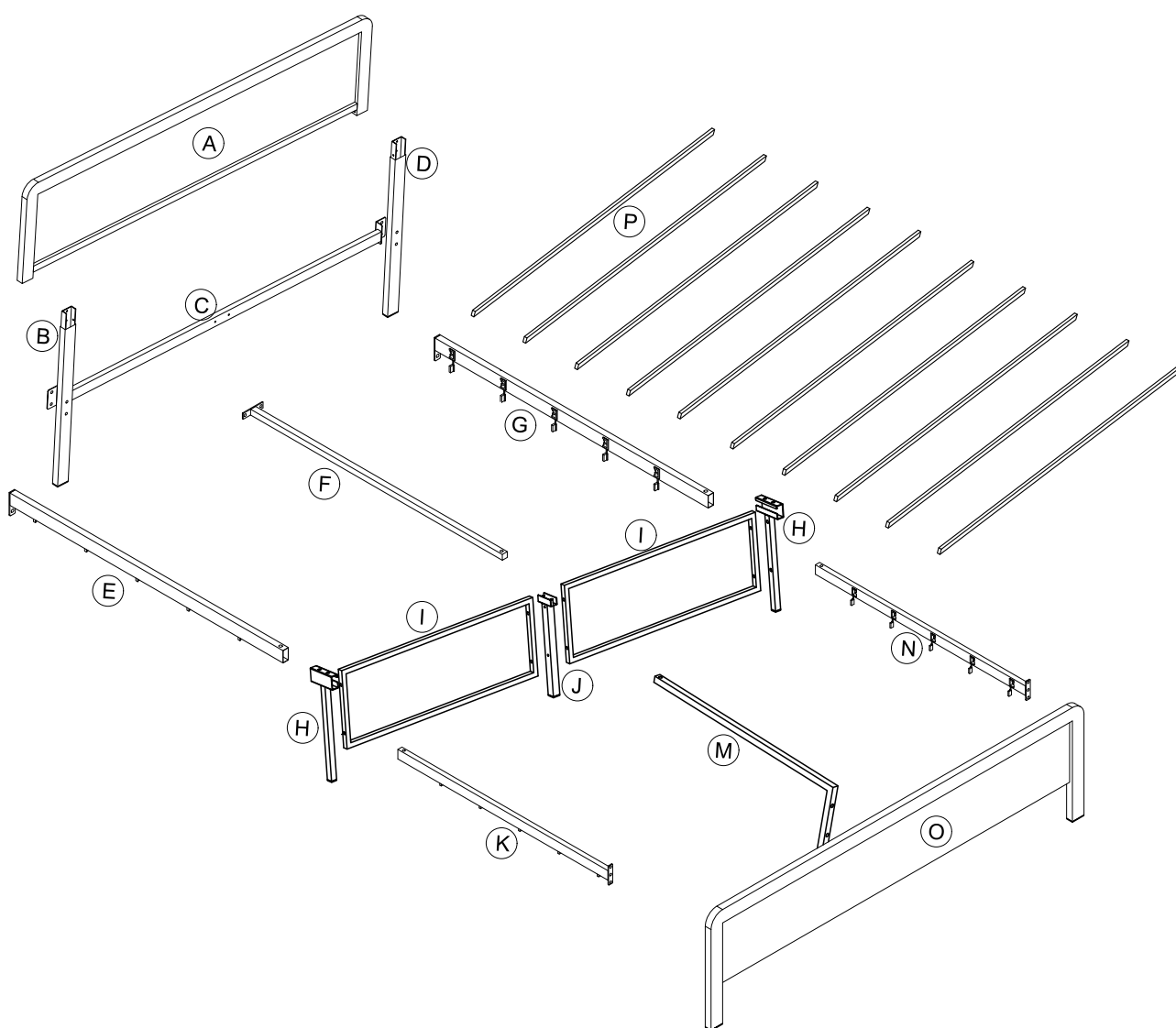

HARDWARE LIST

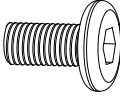
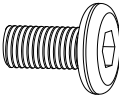
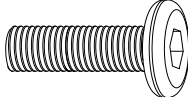
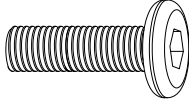
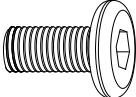
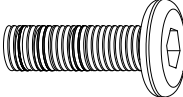
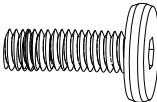
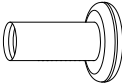
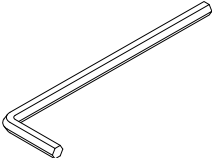
<p>aa x 4</p>  <p>M8*15mm</p>	<p>bb x 4</p>  <p>M6*12mm</p>	<p>cc x 2</p>  <p>M8*35mm</p>	<p>dd x 4</p>  <p>M6*32mm</p>
<p>ee x 6</p>  <p>M6*10mm</p>	<p>ff x 10</p>  <p>M6*28mm</p>	<p>gg x 2</p>  <p>M6*20mm</p>	<p>hh x 6</p>  <p>M6*20mm</p>
<p>ii x 1</p> 			

PRODUCT ASSEMBLY

1

M6*28mm



ff x 8

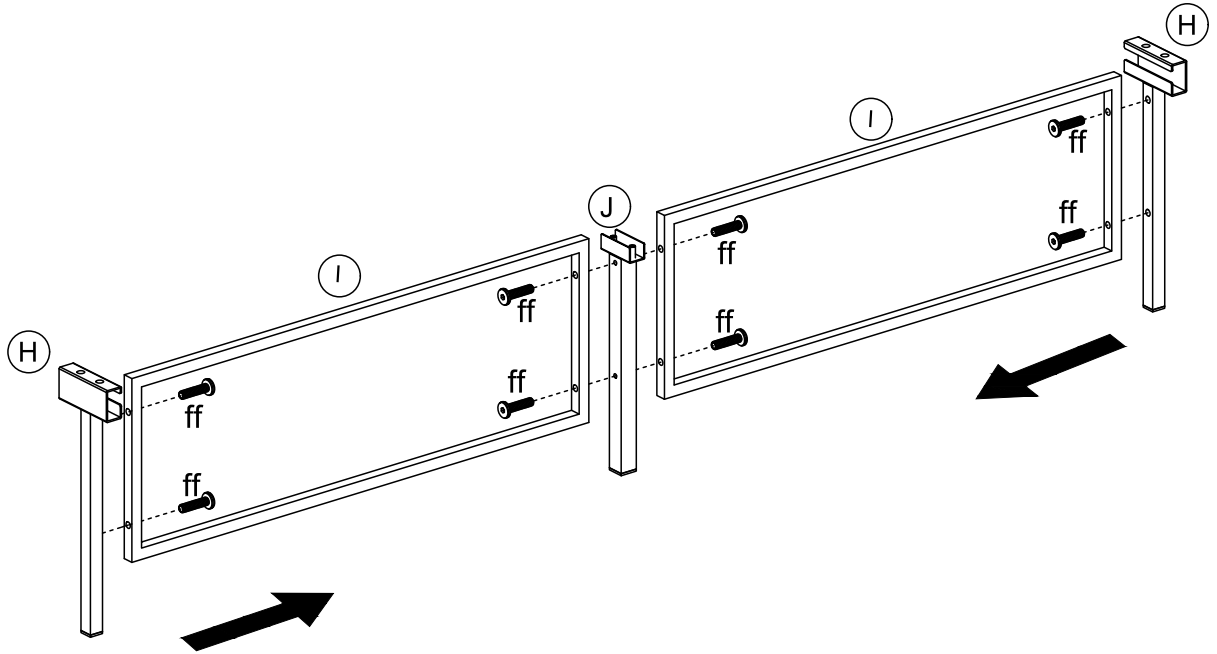

2

M6*32mm

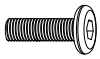

dd x 2

M6*20mm



hh x 2

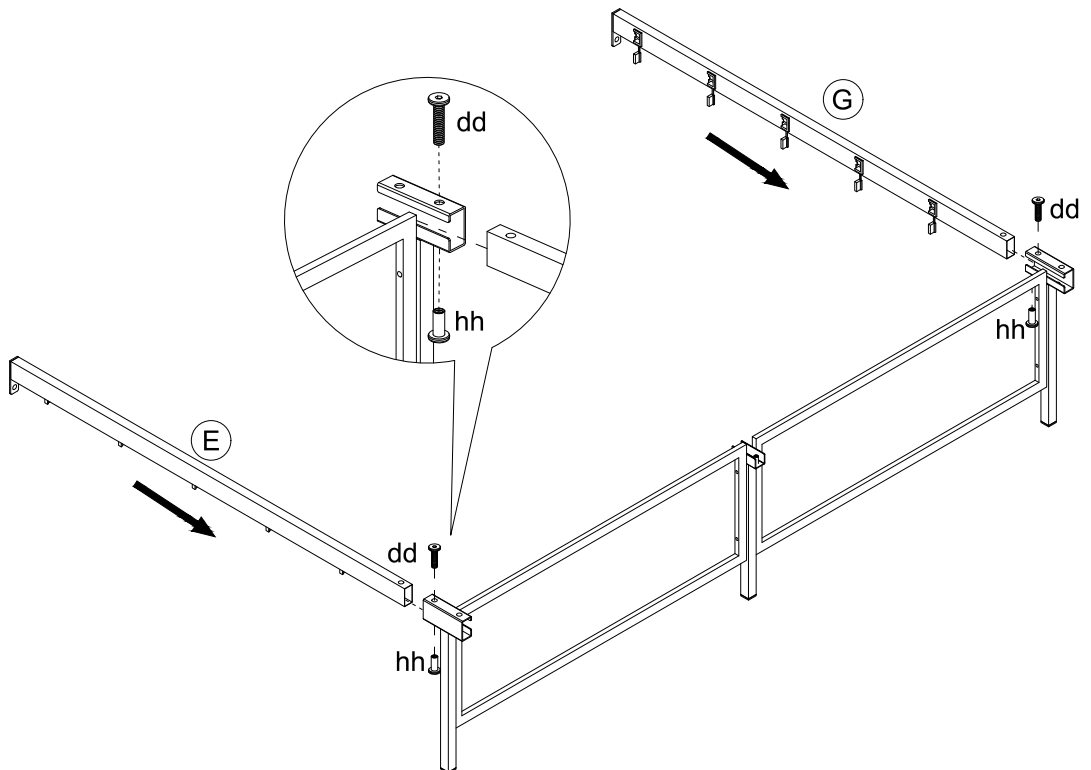

PRODUCT ASSEMBLY

3

M8*35mm



cc x 2

M6*20mm



gg x 2

M6*20mm



hh x 2

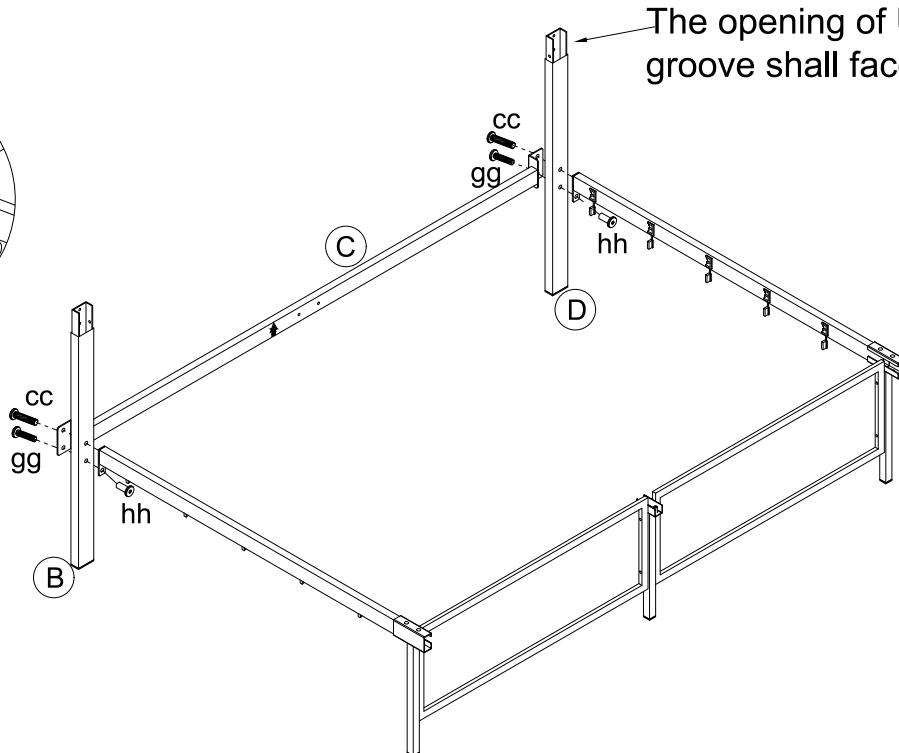
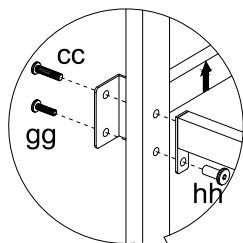

4

Ø6*12mm



bb x 3

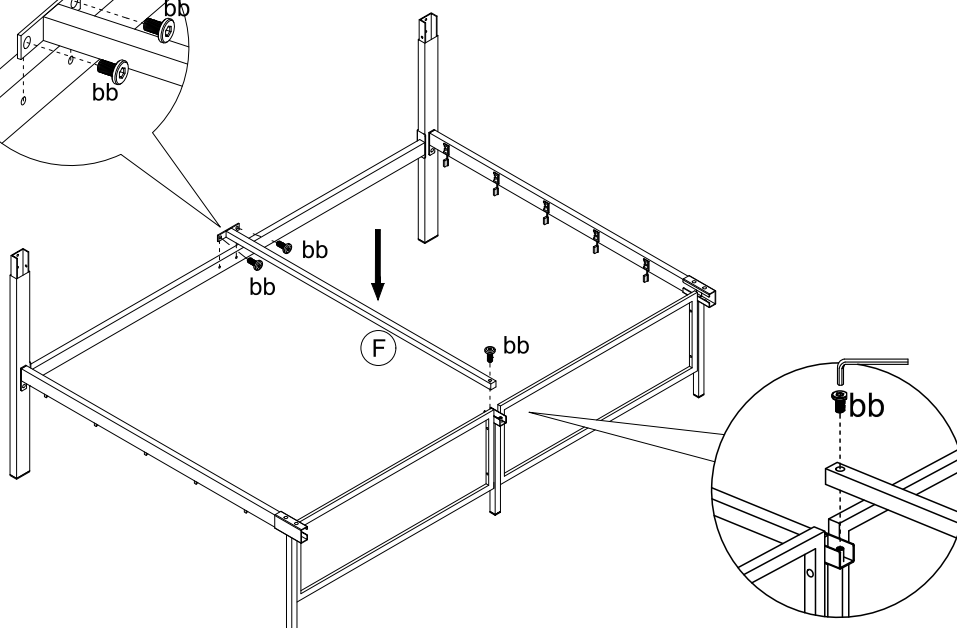
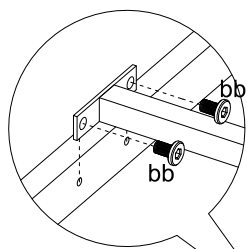

PRODUCT ASSEMBLY

5

M6*32mm



dd x 2

M6*20mm



hh x 2

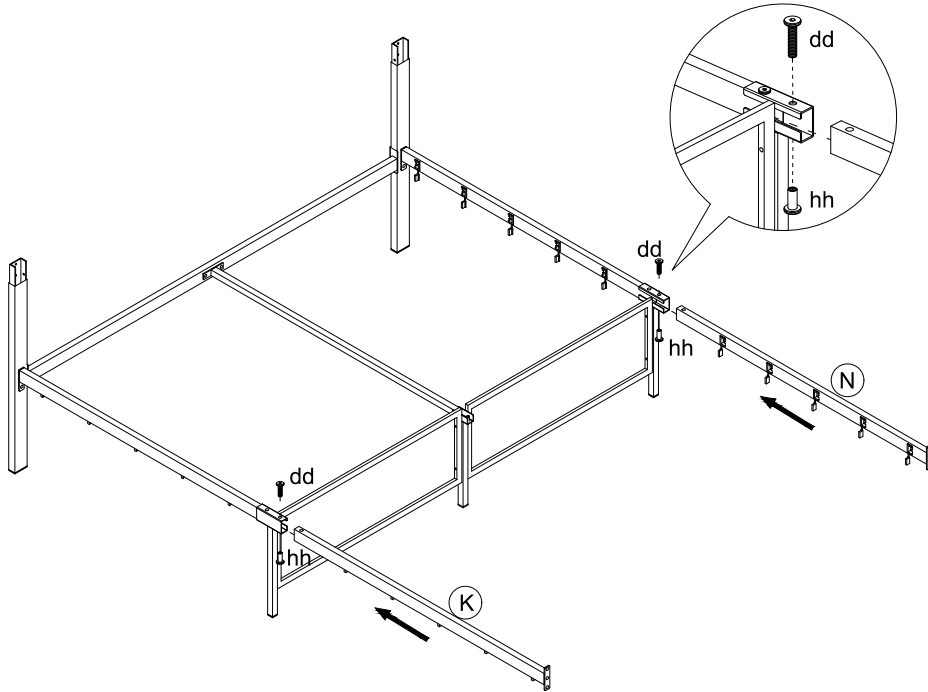

6

M8*15mm



aa x 4

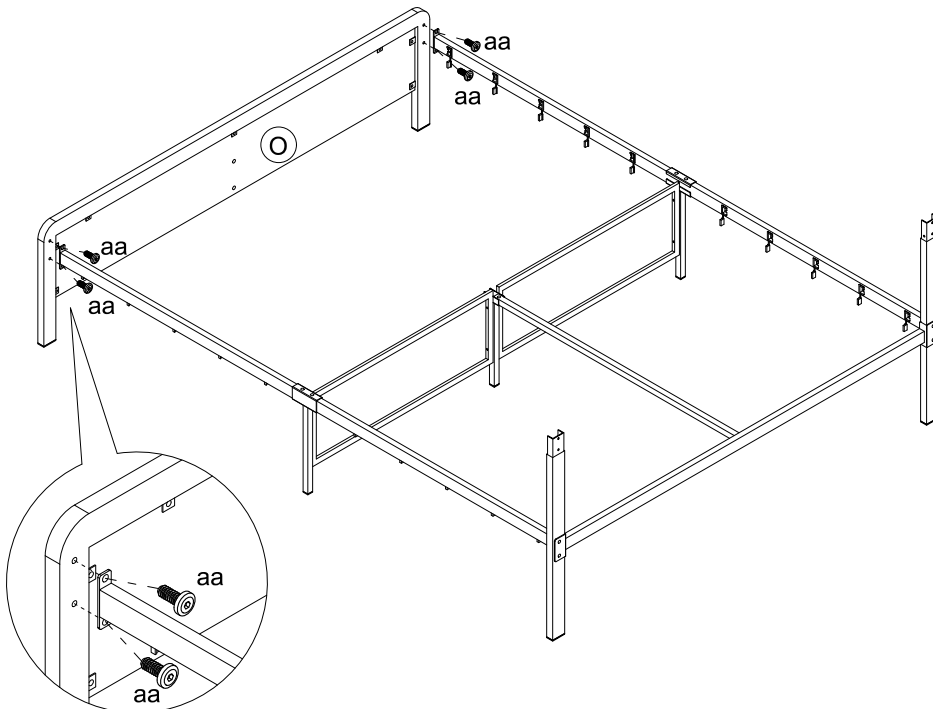

PRODUCT ASSEMBLY

7

M6*28mm



ff x 2

Ø6*12mm



bb x 1

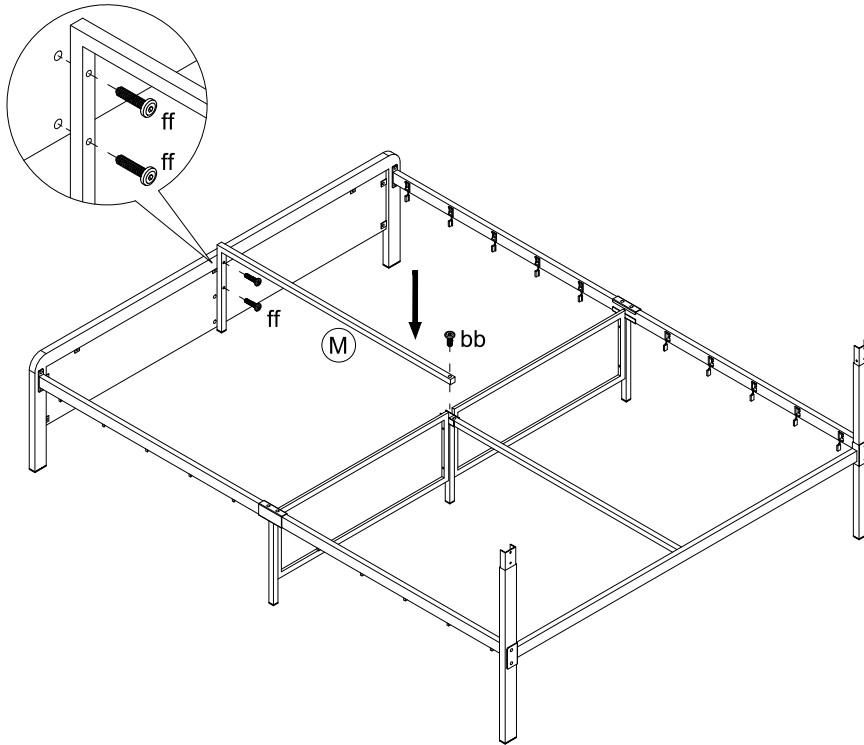

8

M6*10mm



ee x 6

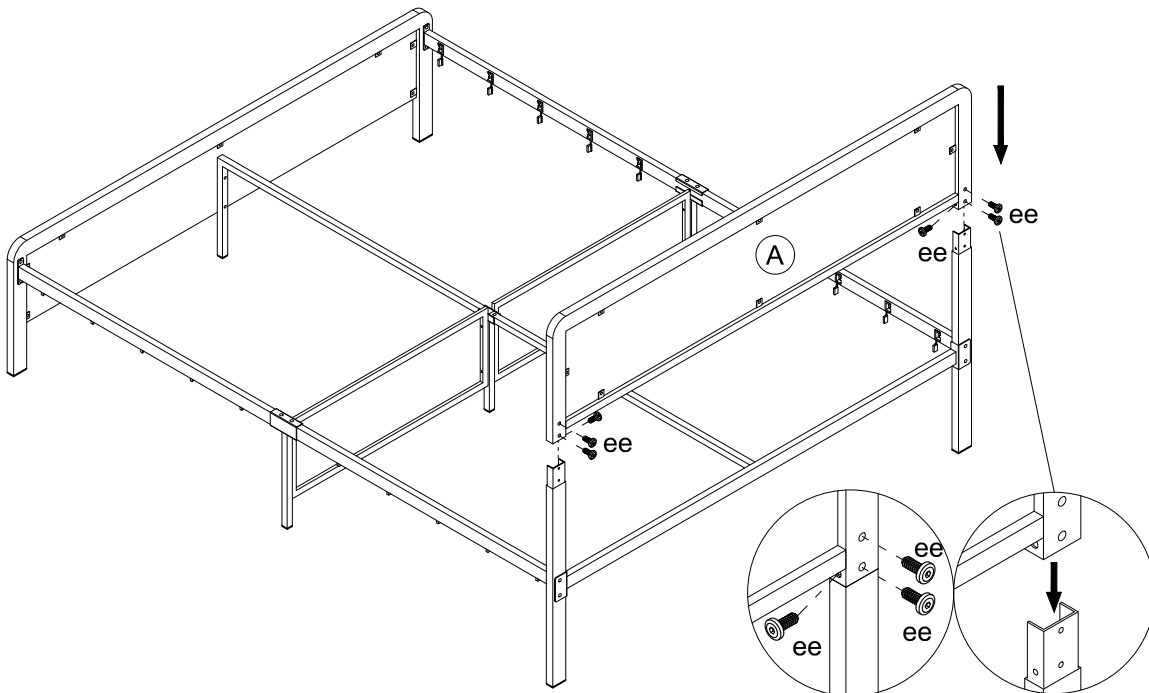

9

