





Assembly Instruction





PART LIST

1	DRESSER	1PC
2	MIRROR	1PC
3	MIRROR SUPPORT	2PCS

ANTI-TIPPING HARDWARE PACK IN-5

A		BRACKET	2PCS
B		TIE WRAP	1PC
C		SCREW #8x2"L	1PC
D		SCREW #8x5/8"L	1PC

HARDWARE LIST IN-6

E		BOLT Ø5/16"x1-1/2"	8 PCS
F		FLAT WASHER 5/16"	8 PCS
G		SPRING WASHER 5/16"	8 PCS
H		ALLEN KEY 5/16"	1 PC

STEP 1

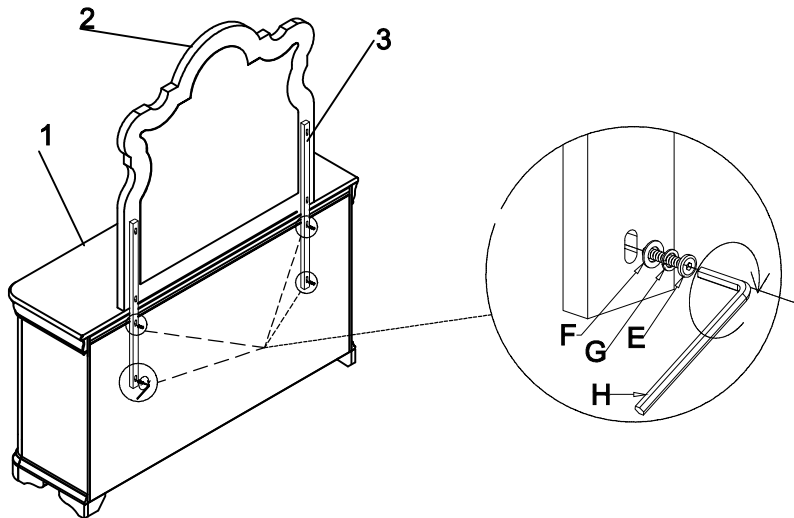

STEP 2

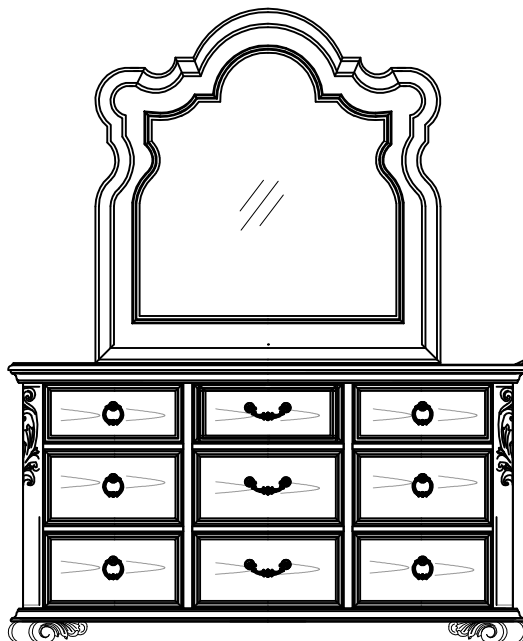

-REMOVE ANTI-TIPPING PACK FROM BACK PANEL.ASSEMBLE IT TO AVOID TIPPING

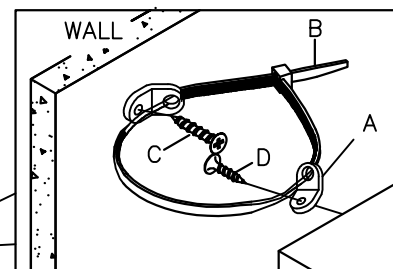

For items use on wooden floor , hard surfaces or carpets it is recommended to install protective pads under all legs and supports to avoid/prevent from damages/scratches and discoloration