

# Before You Start



- ✓ Read through each step carefully and follow the proper order
- ✓ Separate and count all your parts and hardware
- ✓ Give yourself enough room for the assembly process
- ✓ Have the following tools: Flat Head Screwdriver, #2 Phillips Head Screwdriver and Hammer
- ✓ Caution: If using a power drill or power screwdriver for screwing, please be aware of to slow down and stop when screw is tight. Failure to do so may result in stripping the screw. (Assembly speed can be increased by using electric screwdriver)

# Helpful Hints

## PEOPLE NEEDED FOR ASSEMBLY: 1-2

- Open your item in the area you plan to keep it to avoid excessive heavy lifting.
- Identify, sort and count the parts before attempting assembly.
- Compression dowels are lightly tapped in with a hammer.
- Slides are labeled with an R (right) and L (left) for proper placement.
- Make sure to always face the point on the top of the Cam Lock towards the outer edge.
- If there is a back panel in the package, please install it to make sure your unit is complete and sturdy.
- Please fix all the screws provided for the back panel which can enhance product stability. If it is difficult to fix it when tightening, it can be fixed with the help of a hammer and then tightened.
- Do NOT use harsh chemicals or abrasive cleaners on this item.
- Never push, pull, or drag your furniture.



---

# Board Identification

Not actual size

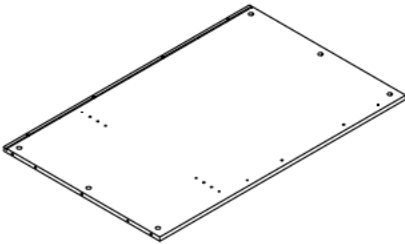

①  
TOP PANEL  
Qty:1

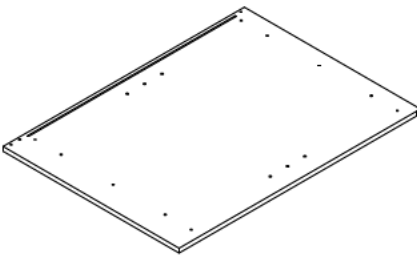

②  
LEFT PANEL  
Qty:1

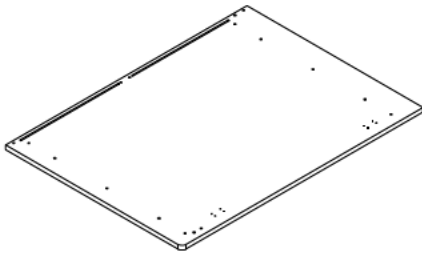

③  
RIGHT PANEL  
Qty:1

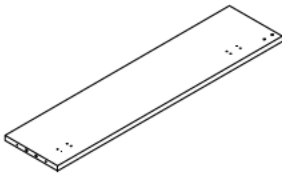

④  
MIDDLE FRONT PANEL  
Qty:1



⑤  
MIDDLE BACK PANEL  
Qty:1



⑥  
RALL  
Qty:1



⑦  
RALL  
Qty:1

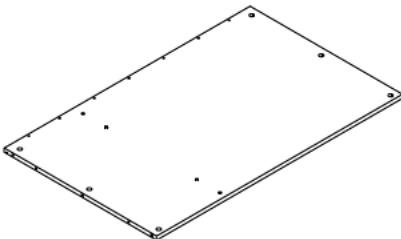

⑧  
BOTTOM PANEL  
Qty:1

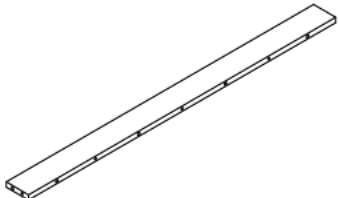

⑨  
RALL  
Qty:1

# Board Identification

Not actual size

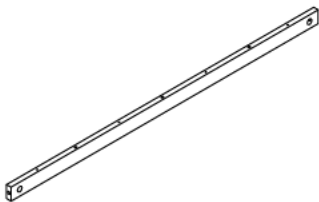

⑩  
RALL  
Qty:1

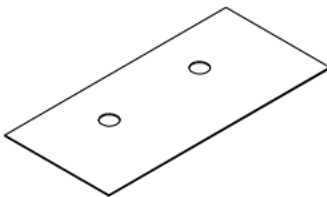

⑪  
LEFT UPPER BACK PANEL  
Qty:1

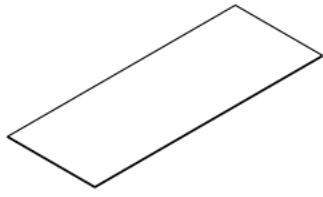

⑫  
LEFT LOWER BACK PANEL  
Qty:1

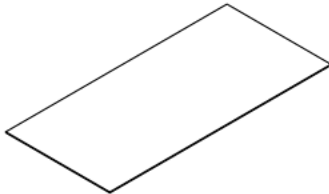

⑬  
RIGHT BACK PANEL  
Qty:1

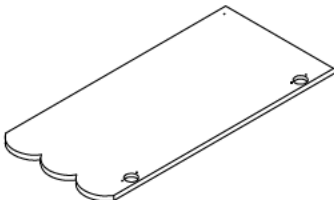

⑭  
LEFT DOOR  
Qty:1

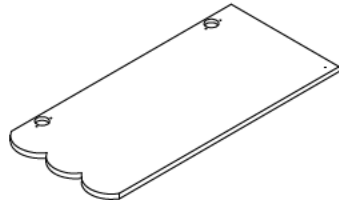

⑮  
RIGHT DOOR  
Qty:1

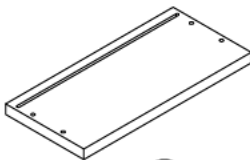

⑯  
DRAWER FRONT PANEL  
Qty:2

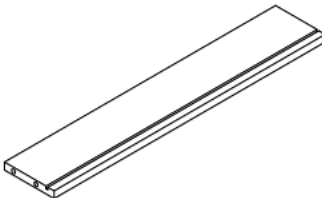

⑰  
DRAWER SIDE PANEL  
Qty:2

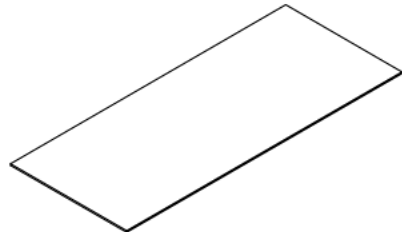

⑱  
DRAWER BOTTOM PANEL  
Qty:1

---

# Board Identification

Not actual size

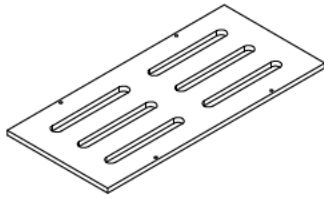

19

DRAWER TOP PANEL  
Qty:1

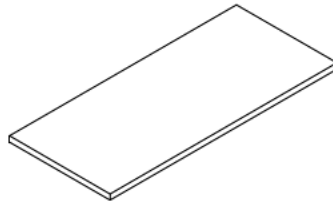

20







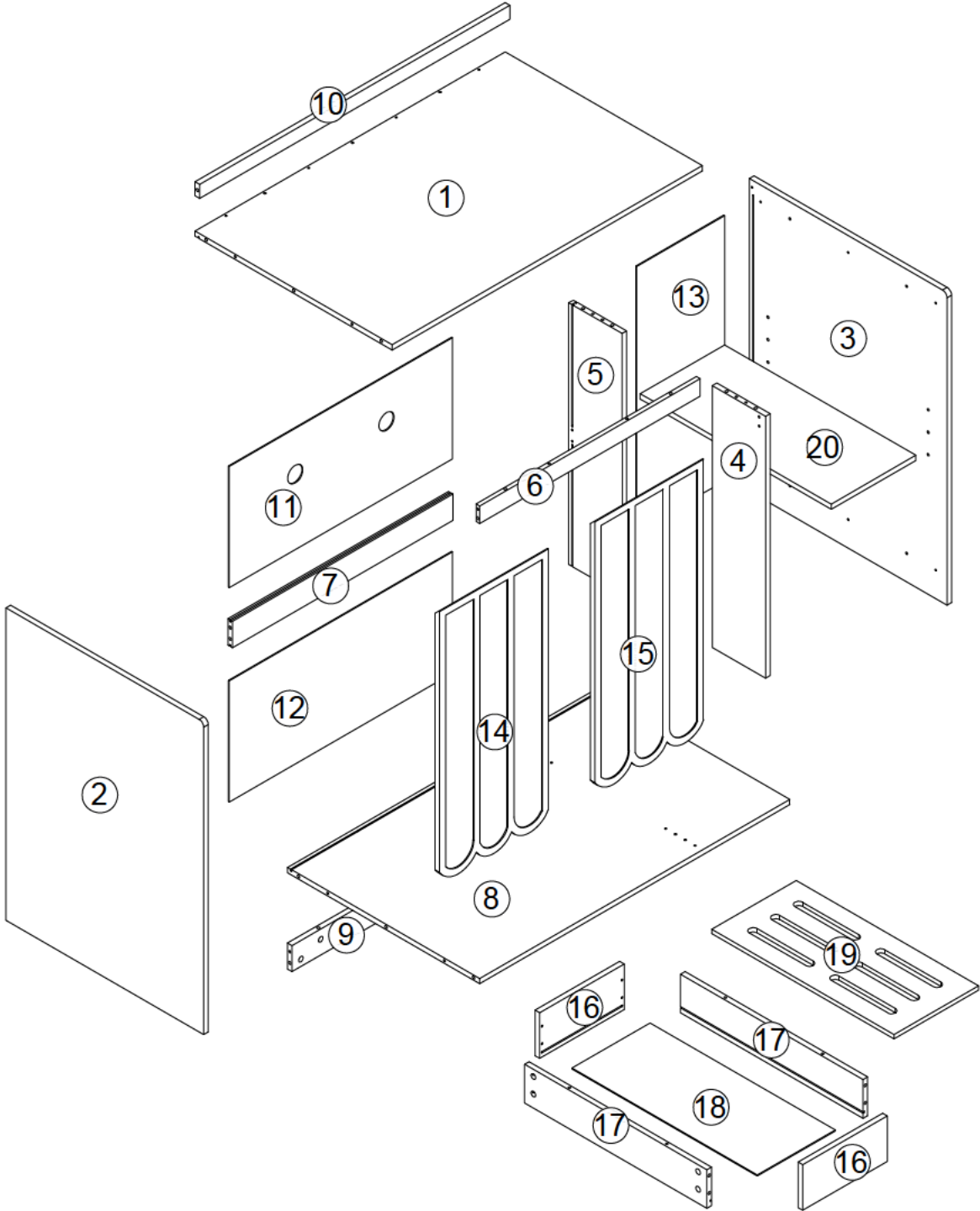

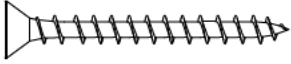
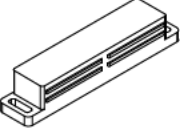
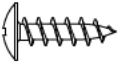

SHELF  
Qty:1

# Board Identification

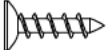
Not actual size

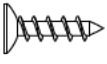

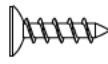
# Part List

 Ø15X9mm <b>(A)</b>   <b>X40</b>	 Ø6.5X35mm <b>(B)</b>   <b>X40</b>	 Ø6X30mm <b>(C)</b>   <b>X32</b>	 Ø4X35mm <b>(D)</b>   <b>X8</b>
CAM LOCK spare: 3	CAM BOLT spare: 3	WOOD DOWEL spare: 2	SCREW spare: 1
 <b>(E)</b>   <b>X1</b>	 Ø3X14mm <b>(F)</b>   <b>X2</b>	 <b>(G)</b>   <b>X2</b>	 Ø3X10mm <b>(H)</b>   <b>X2</b>
MAGNET	SCREW spare: 1	MAGNET PLATE	SCREW spare: 1
 <b>(I)</b>   <b>X4</b>	 Ø4X12mm <b>(J)</b>   <b>X24</b>	 <b>(K)</b>   <b>X18</b>	 Ø3X14mm <b>(L)</b>   <b>X18</b>
HINGE	SCREW spare: 3	SCREW spare: 2	SCREW spare: 3
 <b>(M)</b>   <b>X4</b>	 Ø20mm <b>(N)</b>   <b>X8</b>		
SHELF SUPPORT spare:1	HOLE PASTE spare:1		

---

# Part List

---

## Cam Lock Fastening System

Insert the cam bolt into  
the hole first, then insert  
the cam lock and lock it,

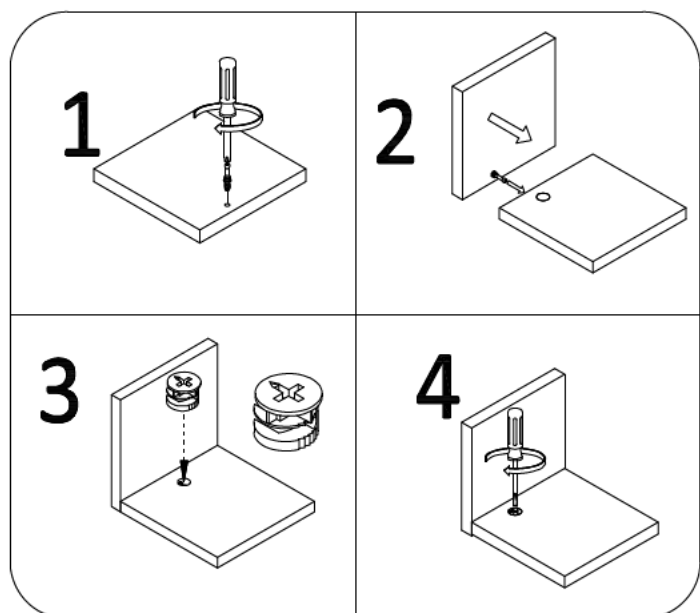

# STEP 1

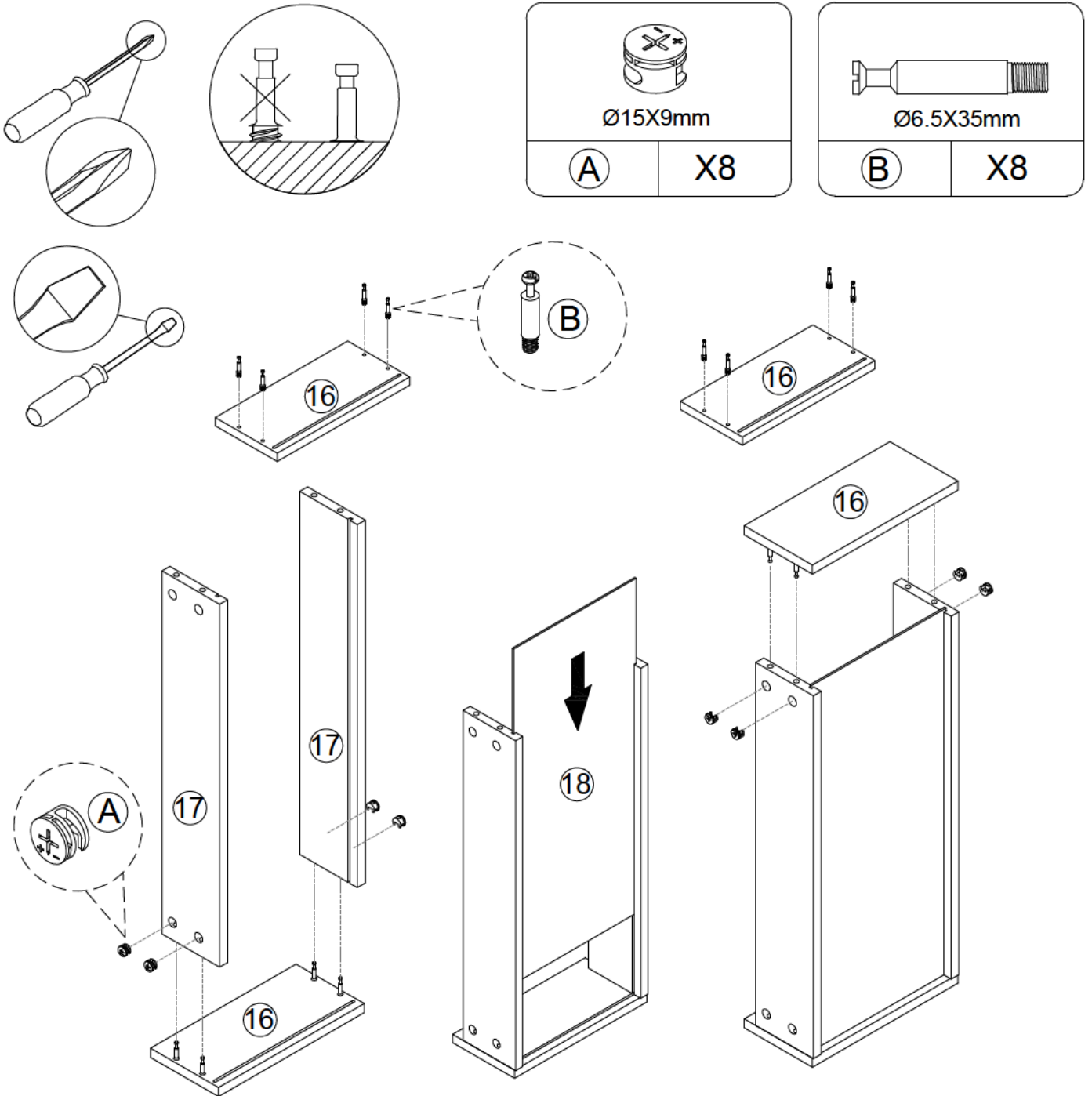

Insert the cam bolt into the hole first, then insert the cam lock and lock it.

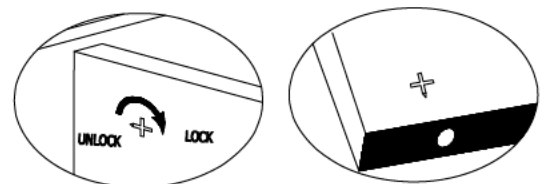

proper orientation of CAM Lock

# STEP2

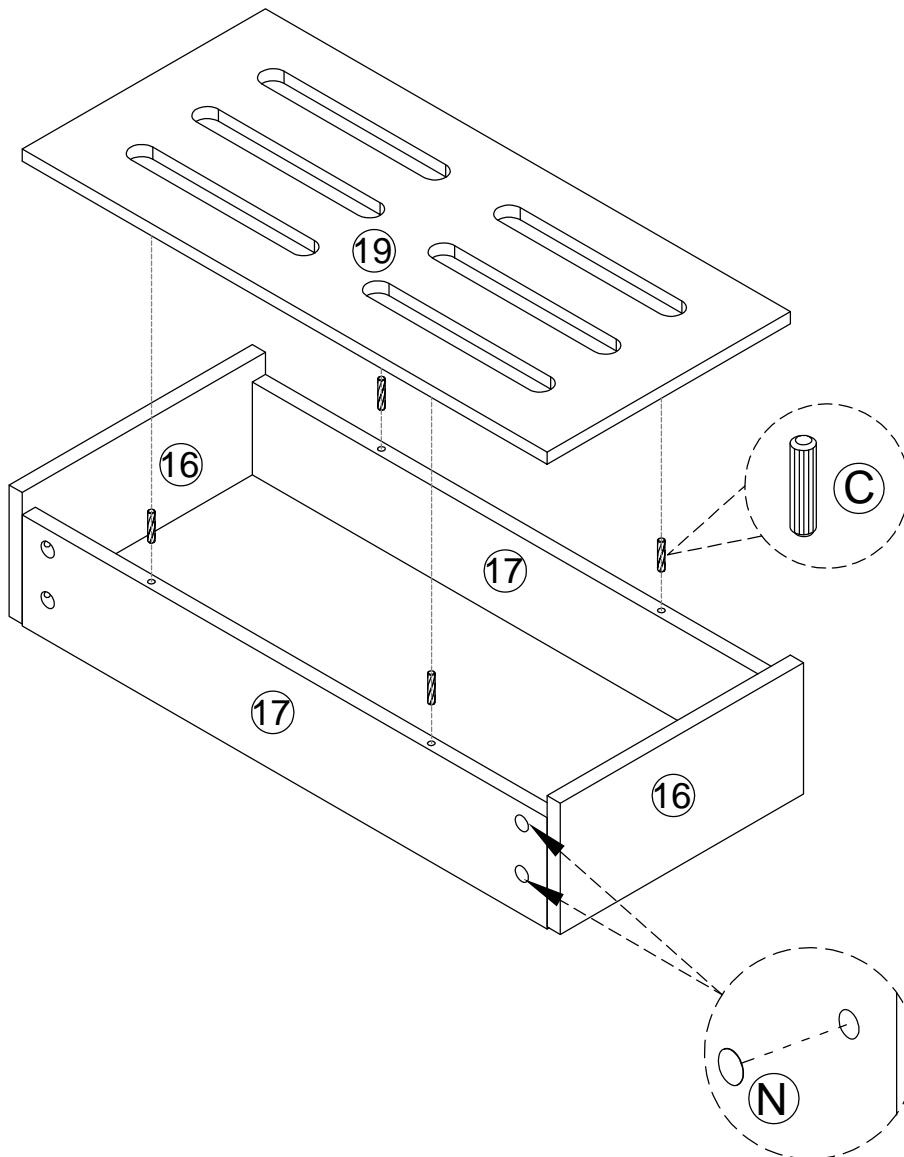
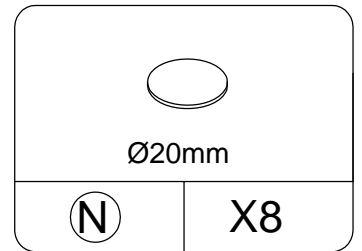
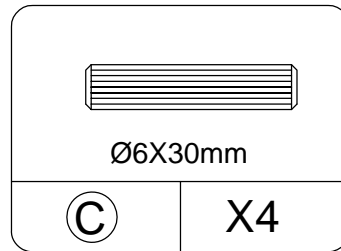

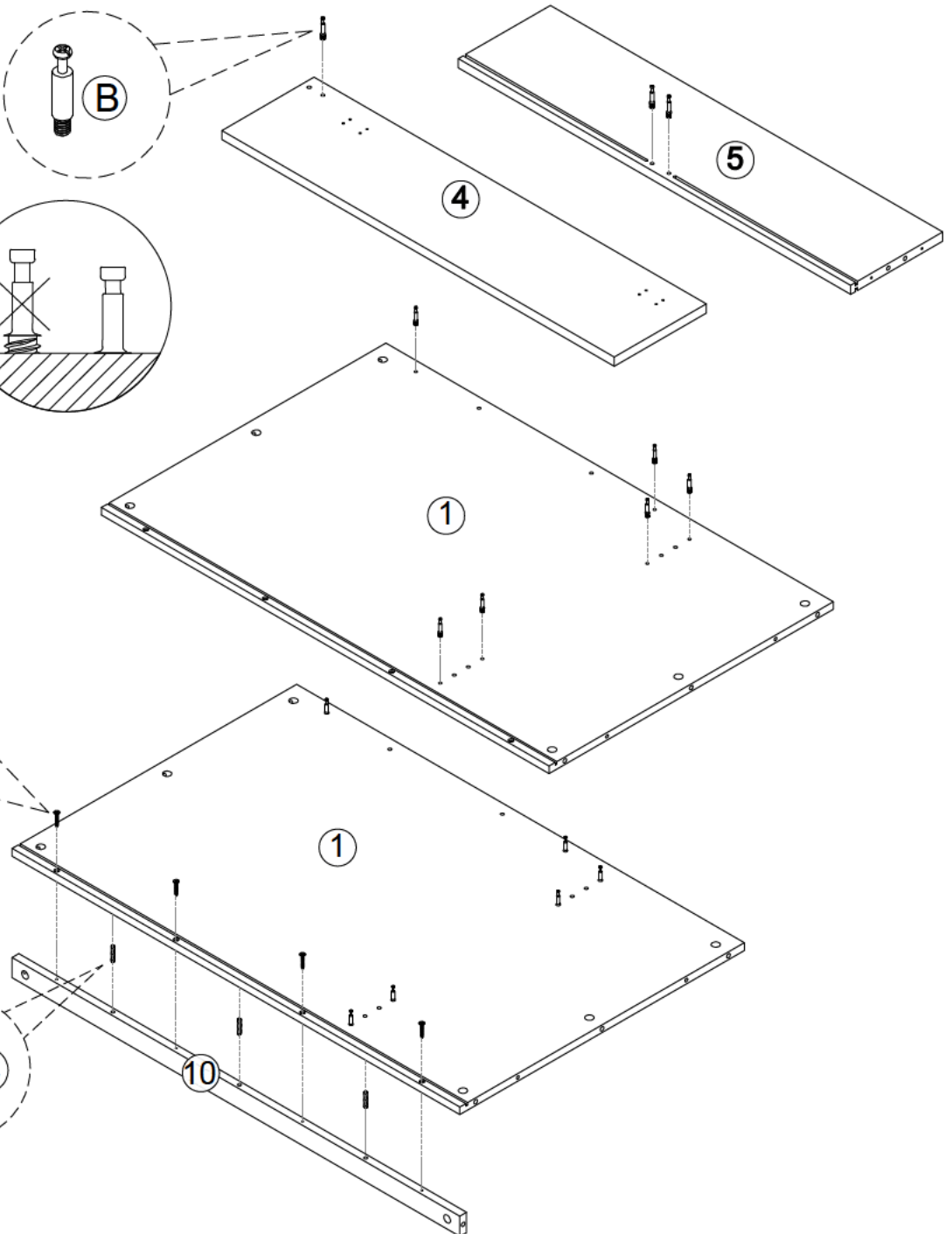
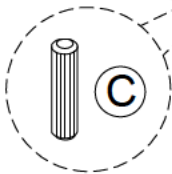
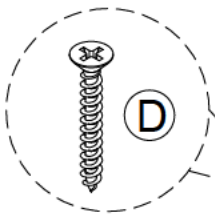
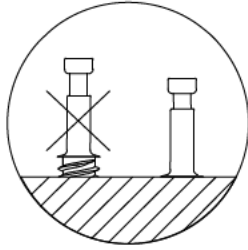
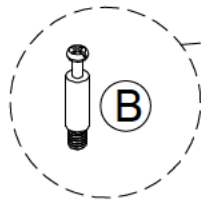
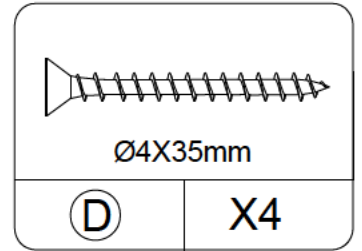
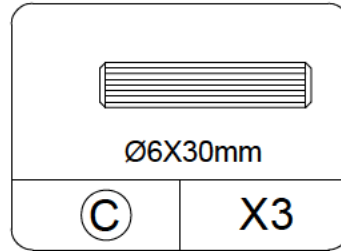
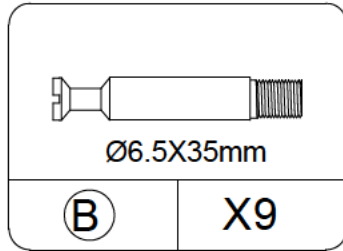
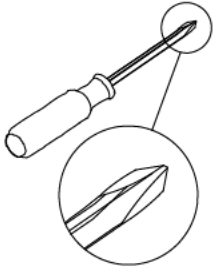

Stick the exposed holes of the cabinet body with hole stickers (N)

# STEP 3

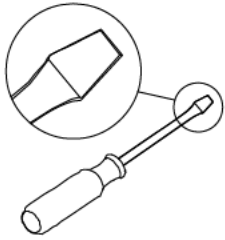
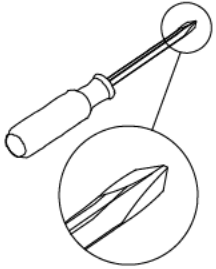

# STEP4



	
Ø15X9mm	
<b>A</b>	X1

	
Ø6X30mm	
<b>C</b>	X1

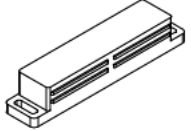
	
<b>E</b>	X1

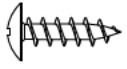
	
Ø3X14mm	
<b>F</b>	X2

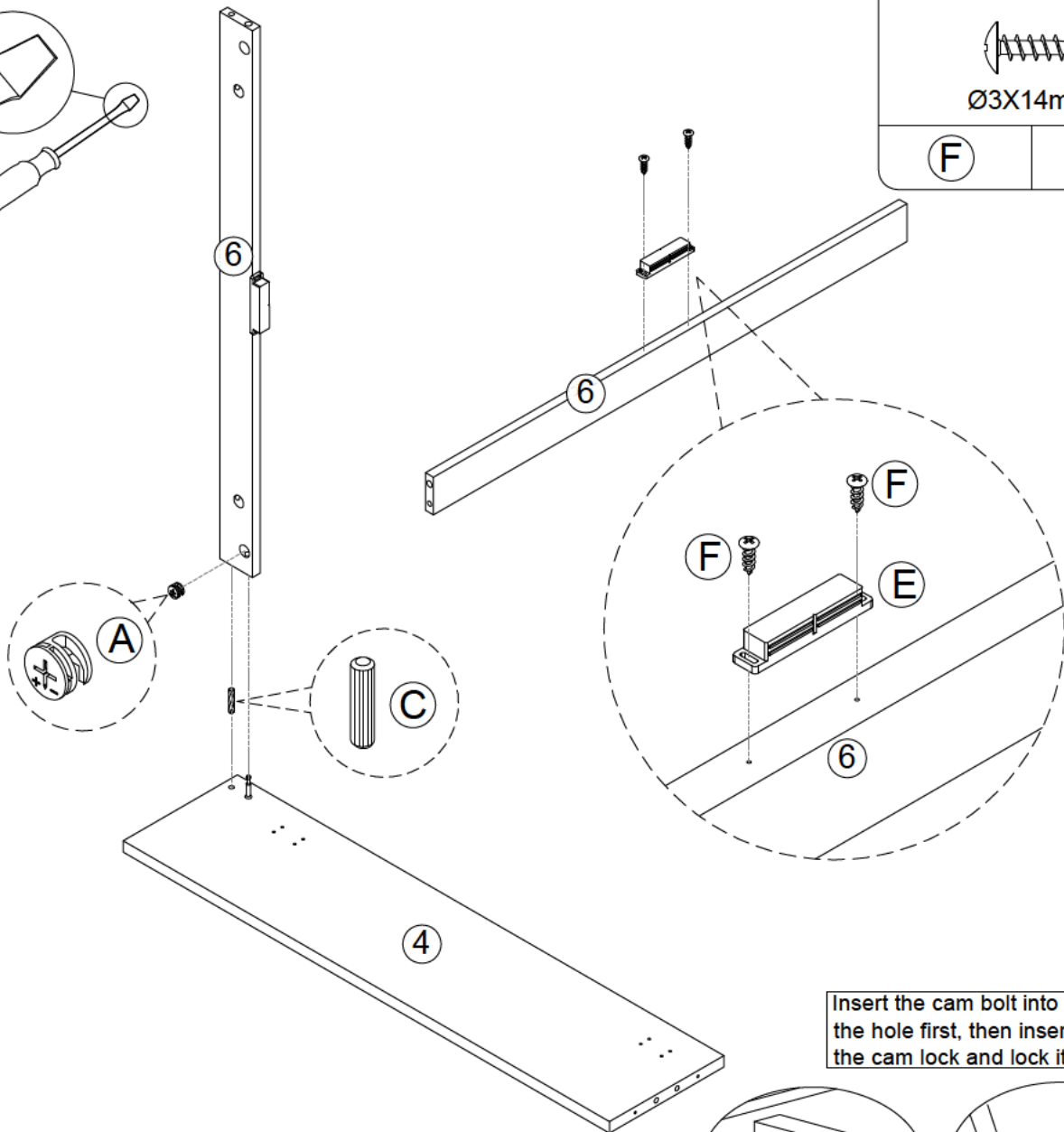

Insert the cam bolt into the hole first, then insert the cam lock and lock it.

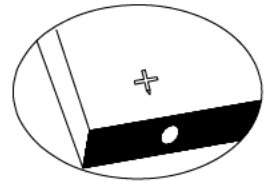

proper orientation of CAM Lock

# STEP 5

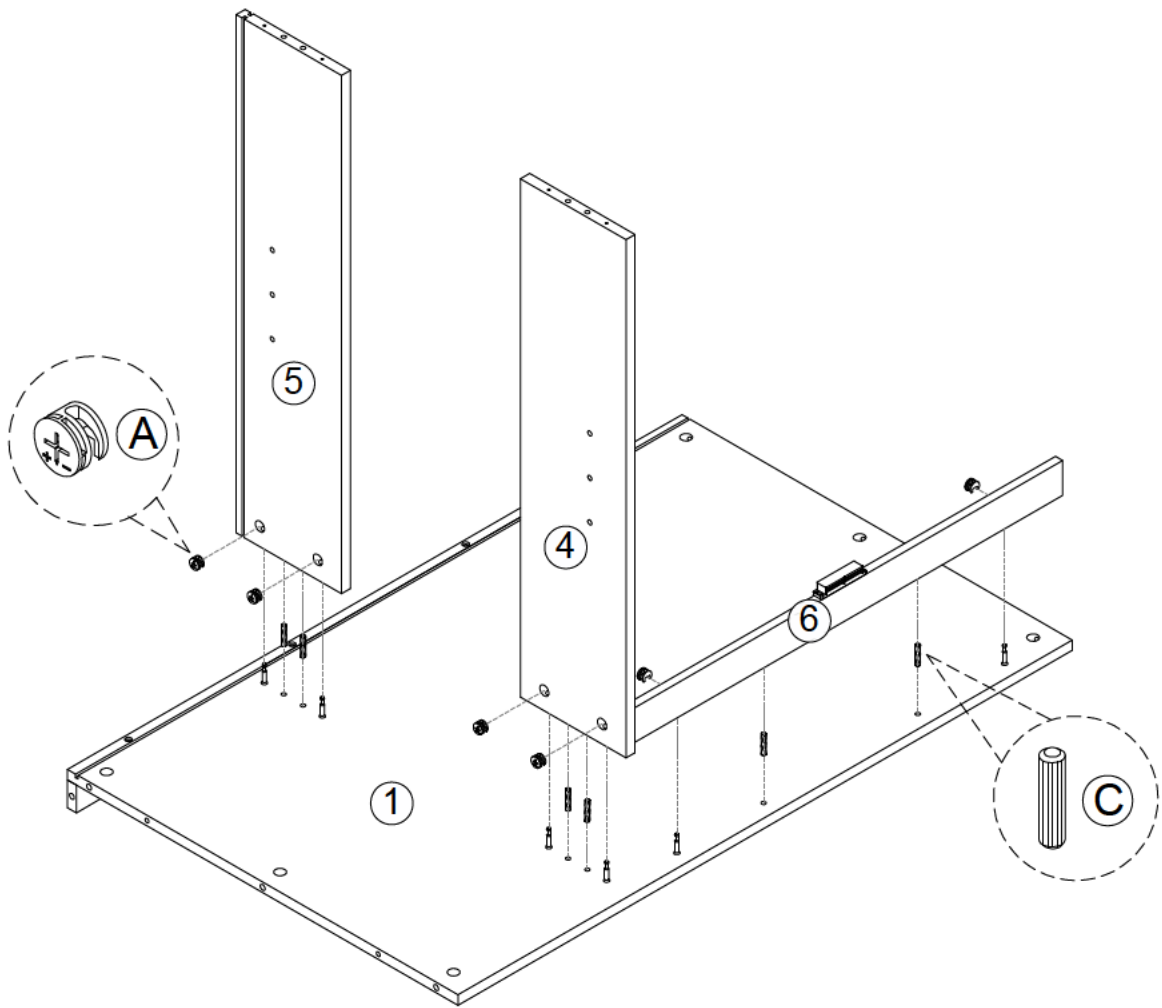
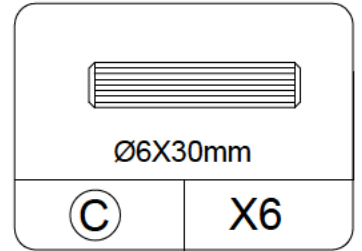
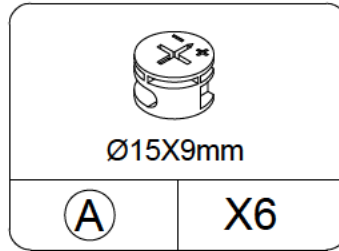
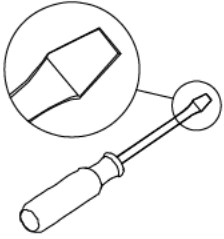

Insert the cam bolt into the hole first, then insert the cam lock and lock it.

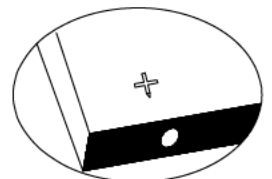

proper orientation of CAM Lock

# STEP 6

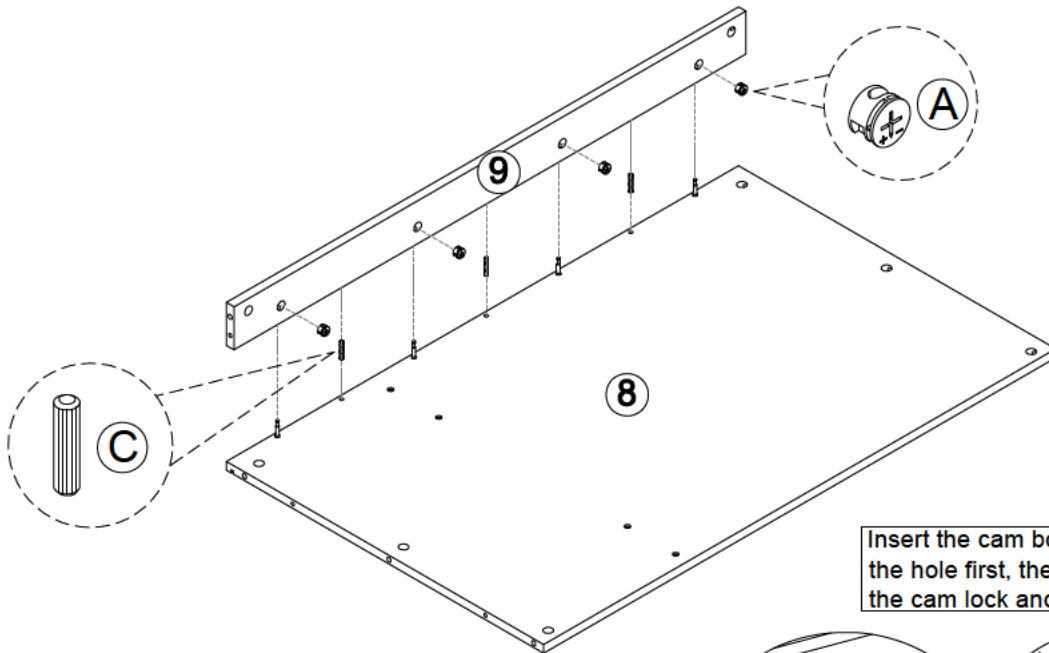
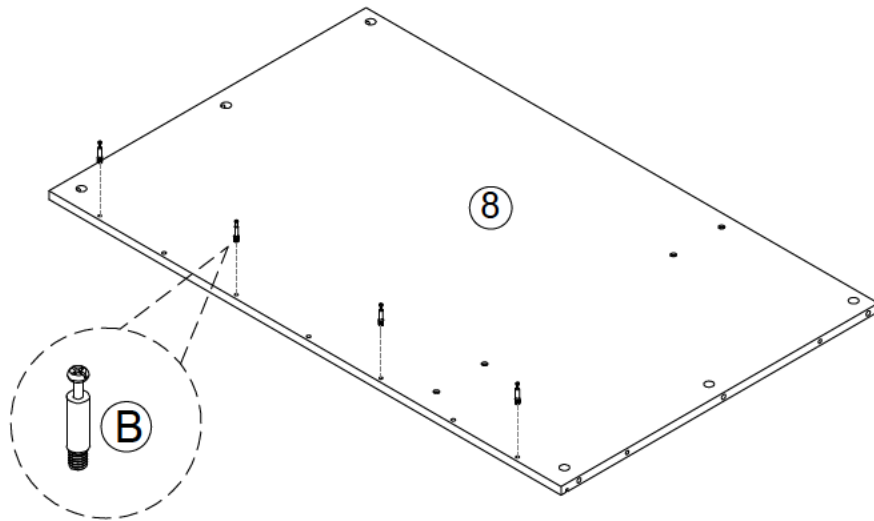
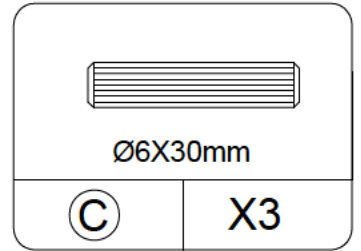
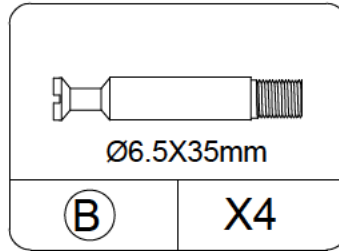
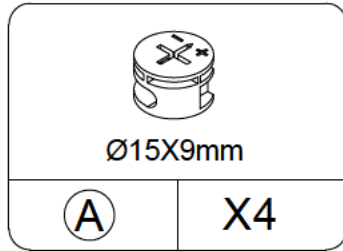
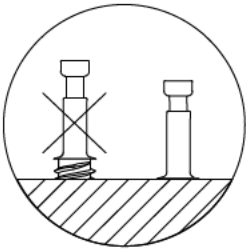
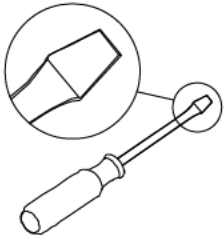
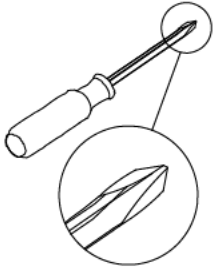

Insert the cam bolt into the hole first, then insert the cam lock and lock it.

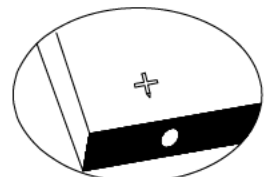

proper orientation of CAM Lock

# STEP 7

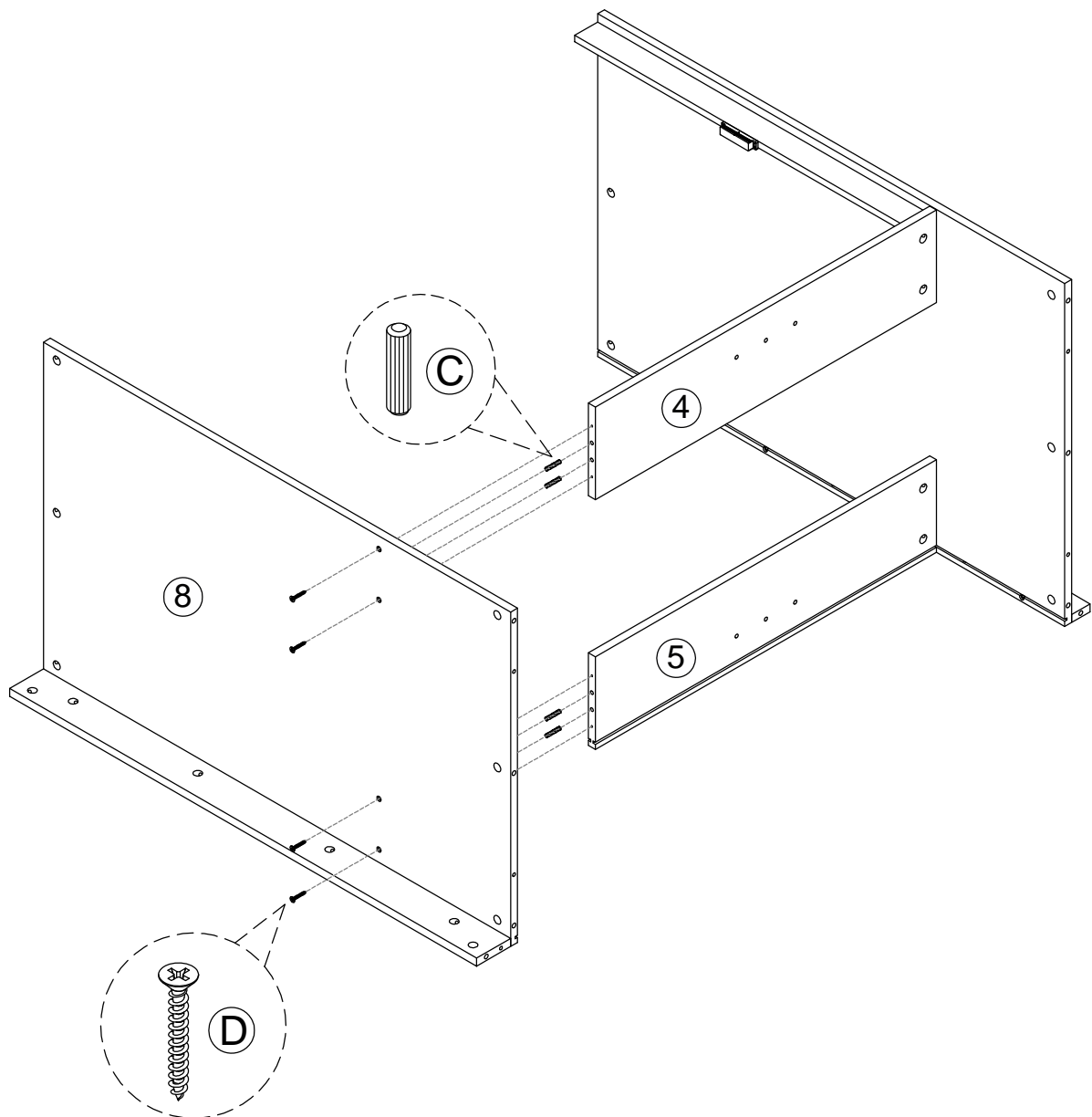
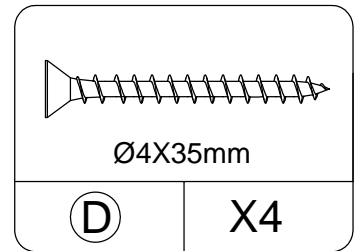
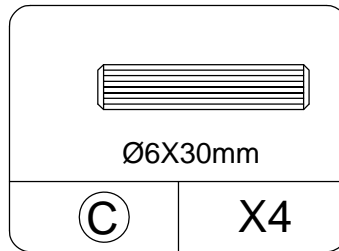
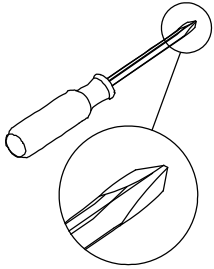

# STEP 8

---

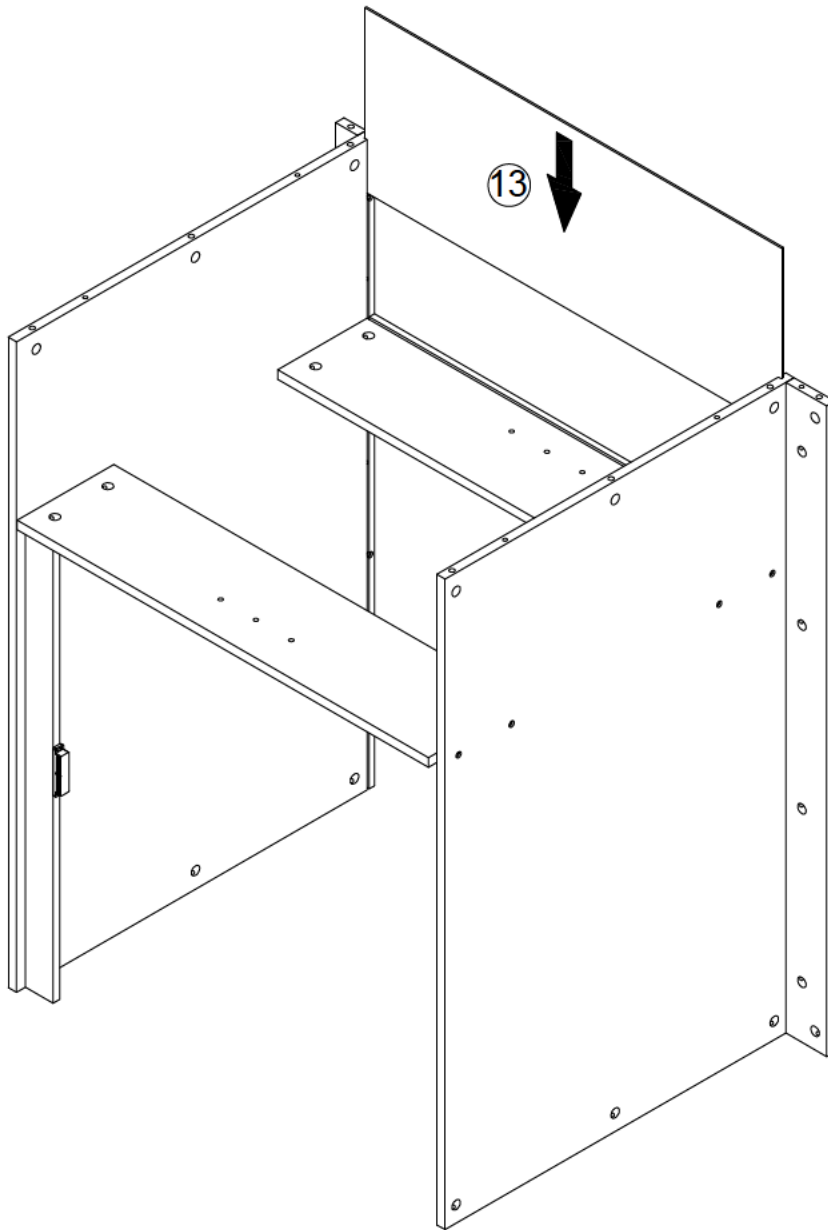

# STEP 9

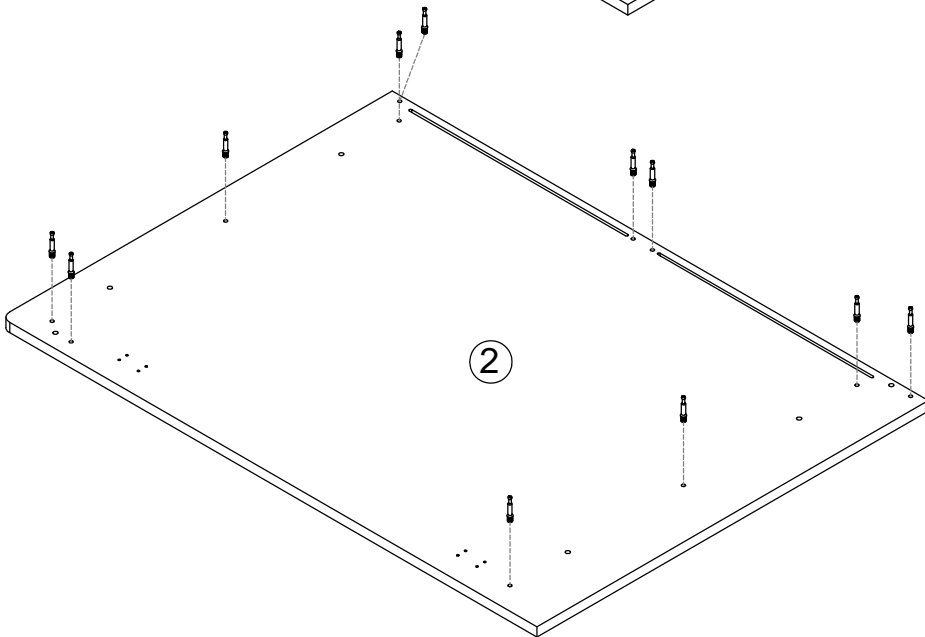
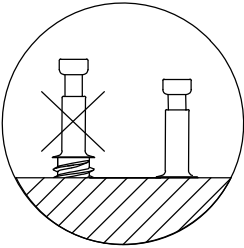
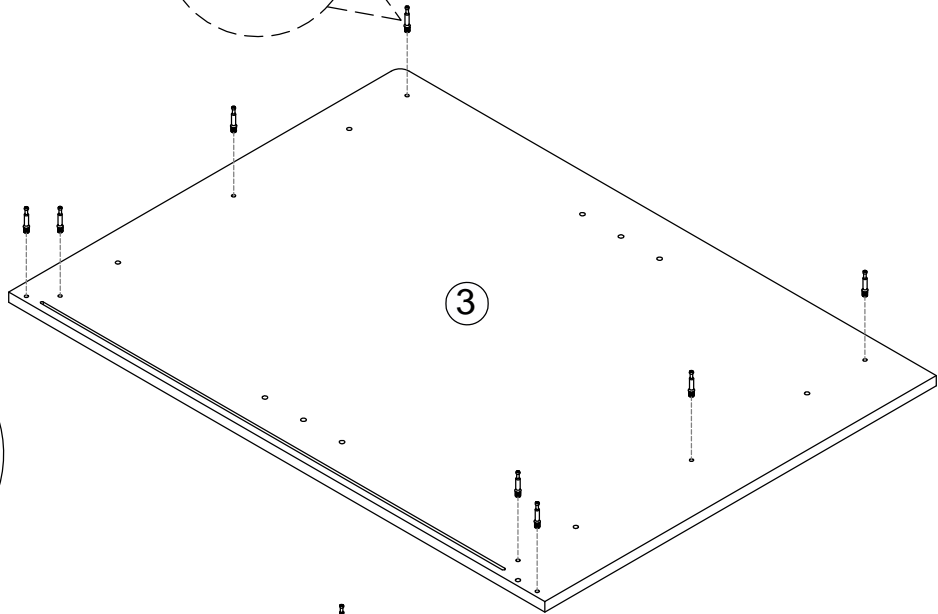
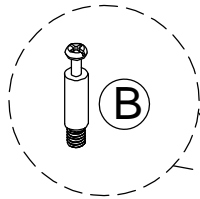
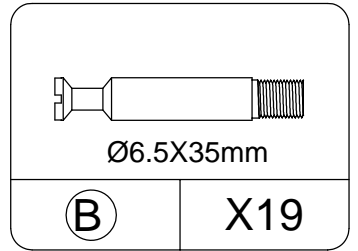
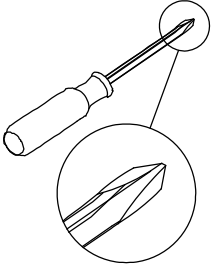

# STEP 10

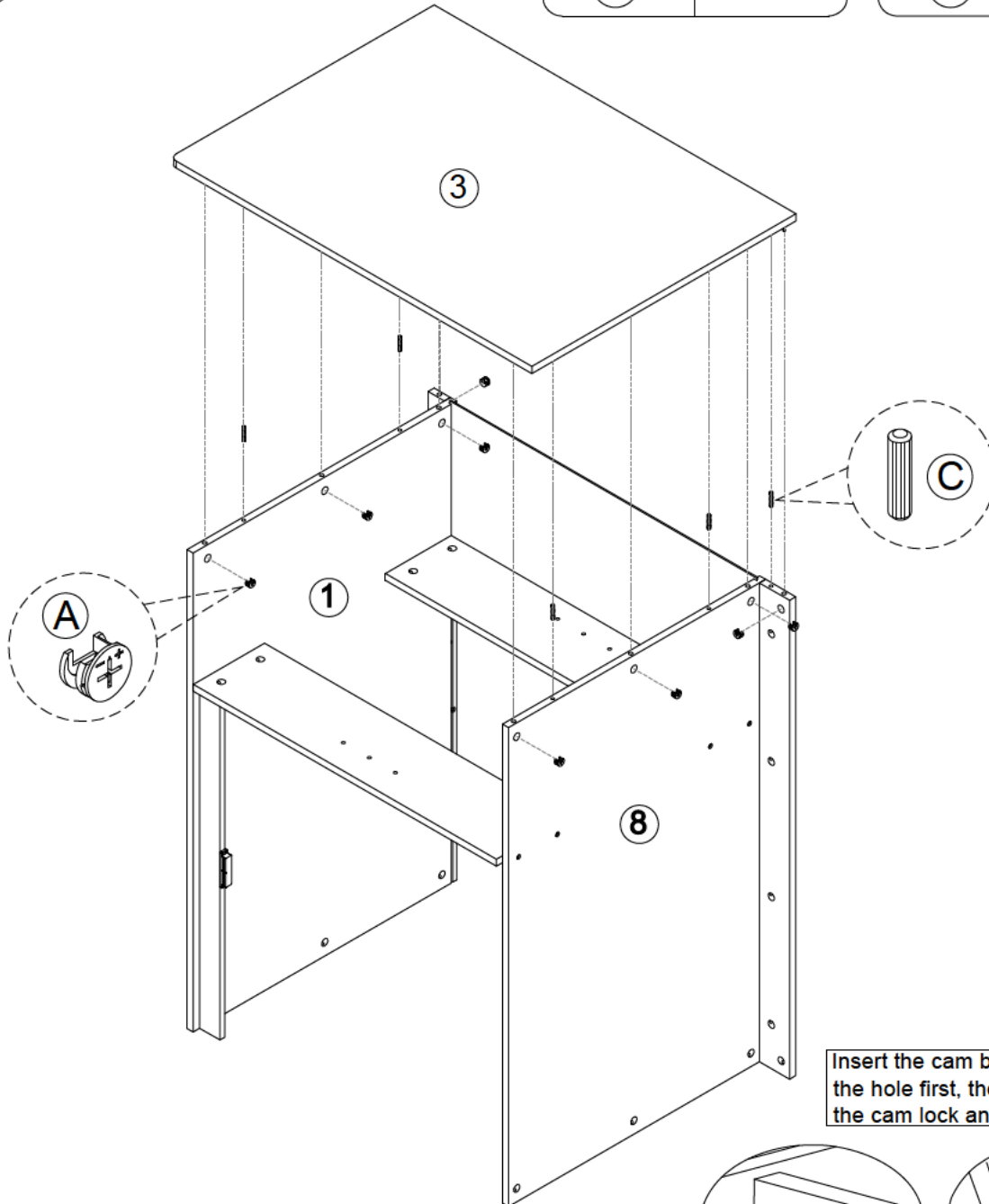
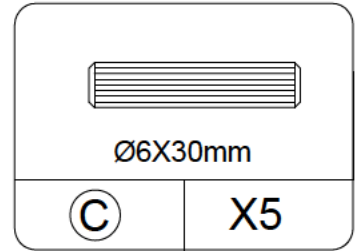
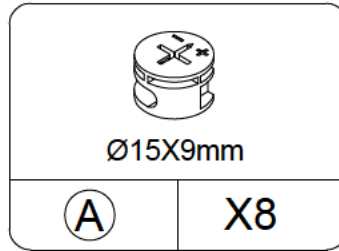
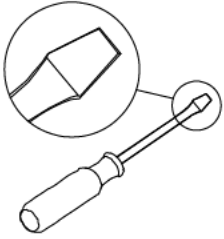

Insert the cam bolt into the hole first, then insert the cam lock and lock it.

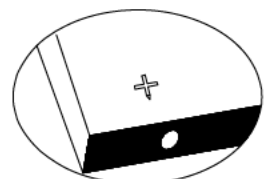

proper orientation of CAM Lock

# STEP 11

	
Ø15X9mm	
<b>A</b>	<b>X2</b>

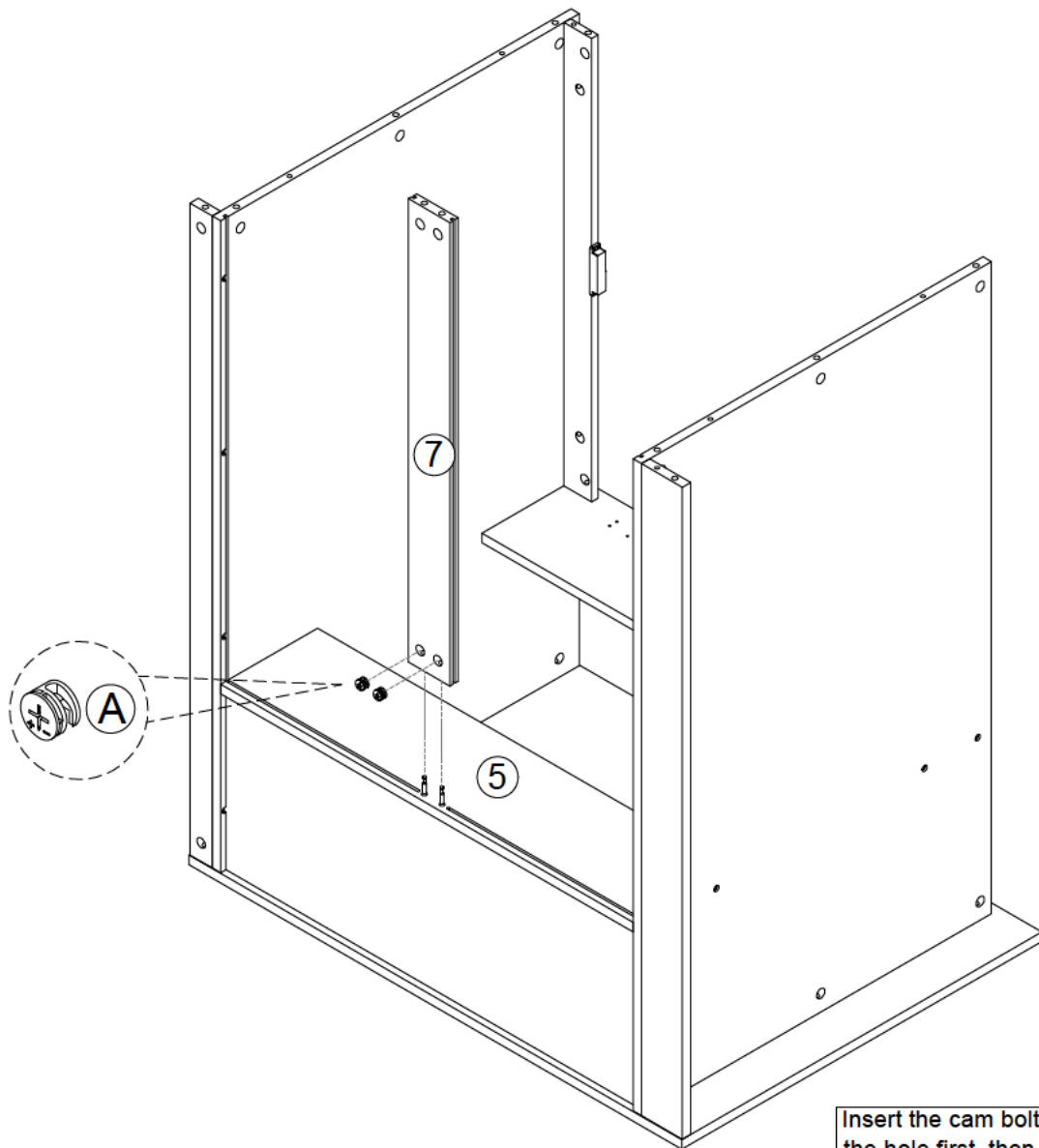

Insert the cam bolt into the hole first, then insert the cam lock and lock it.

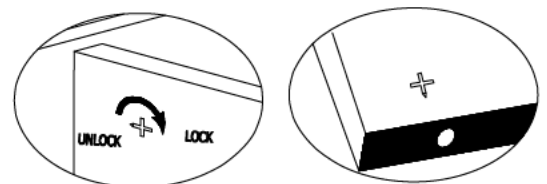

proper orientation of CAM Lock

# STEP 12

---

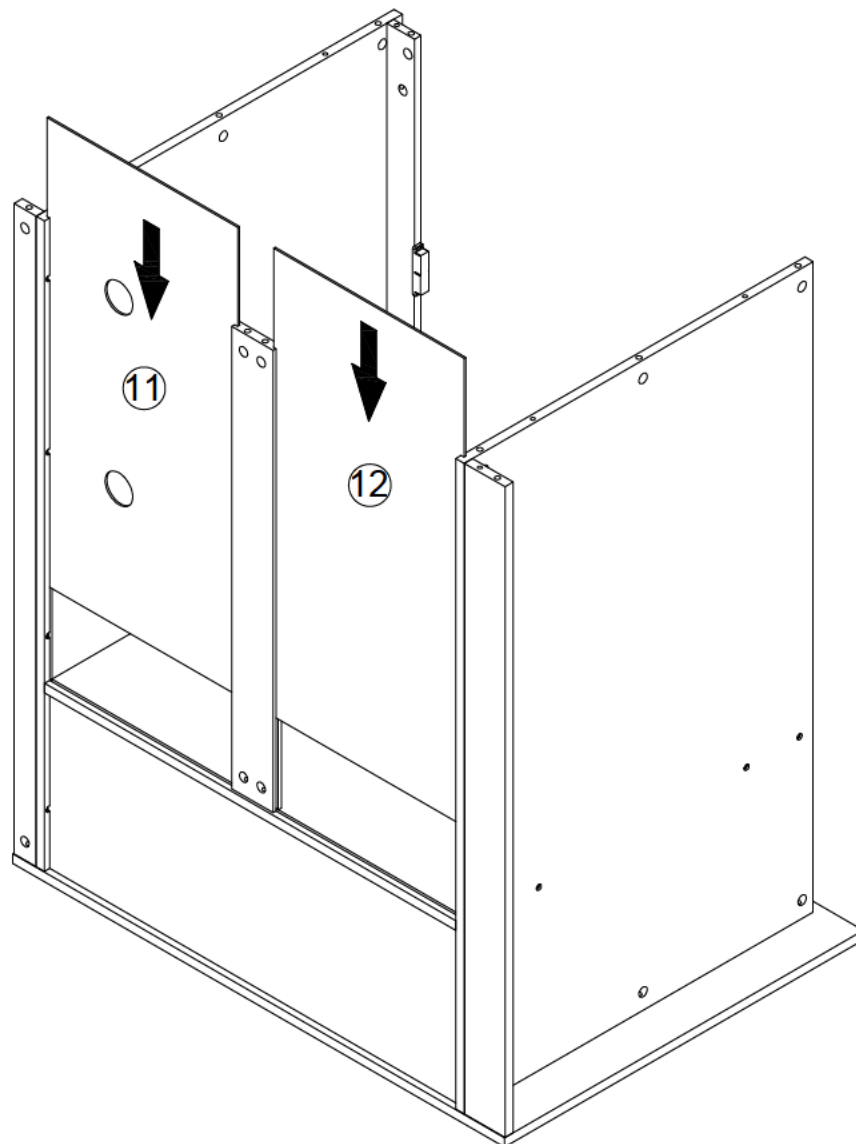

# STEP 13

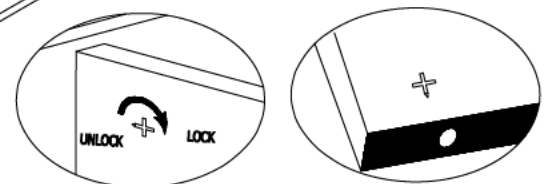
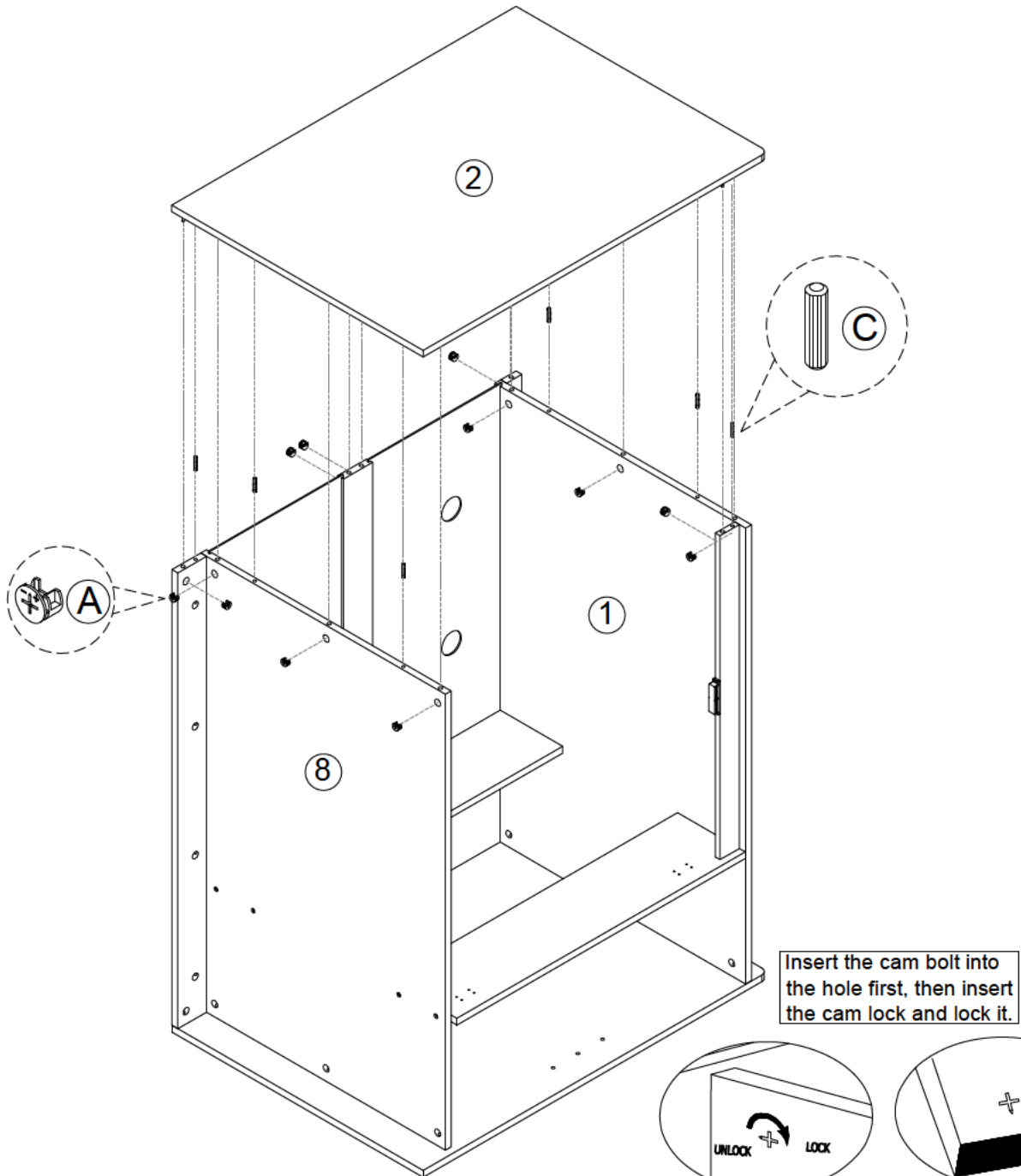
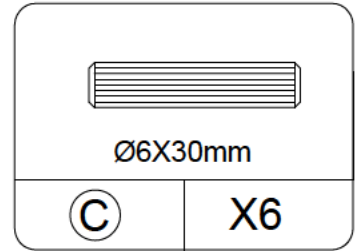
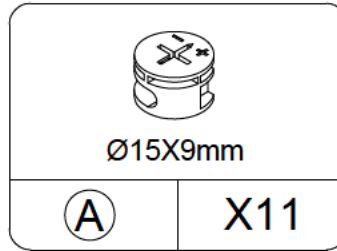
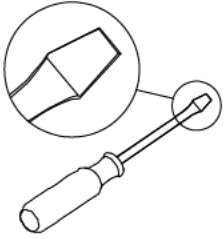

proper orientation of CAM Lock

# STEP14

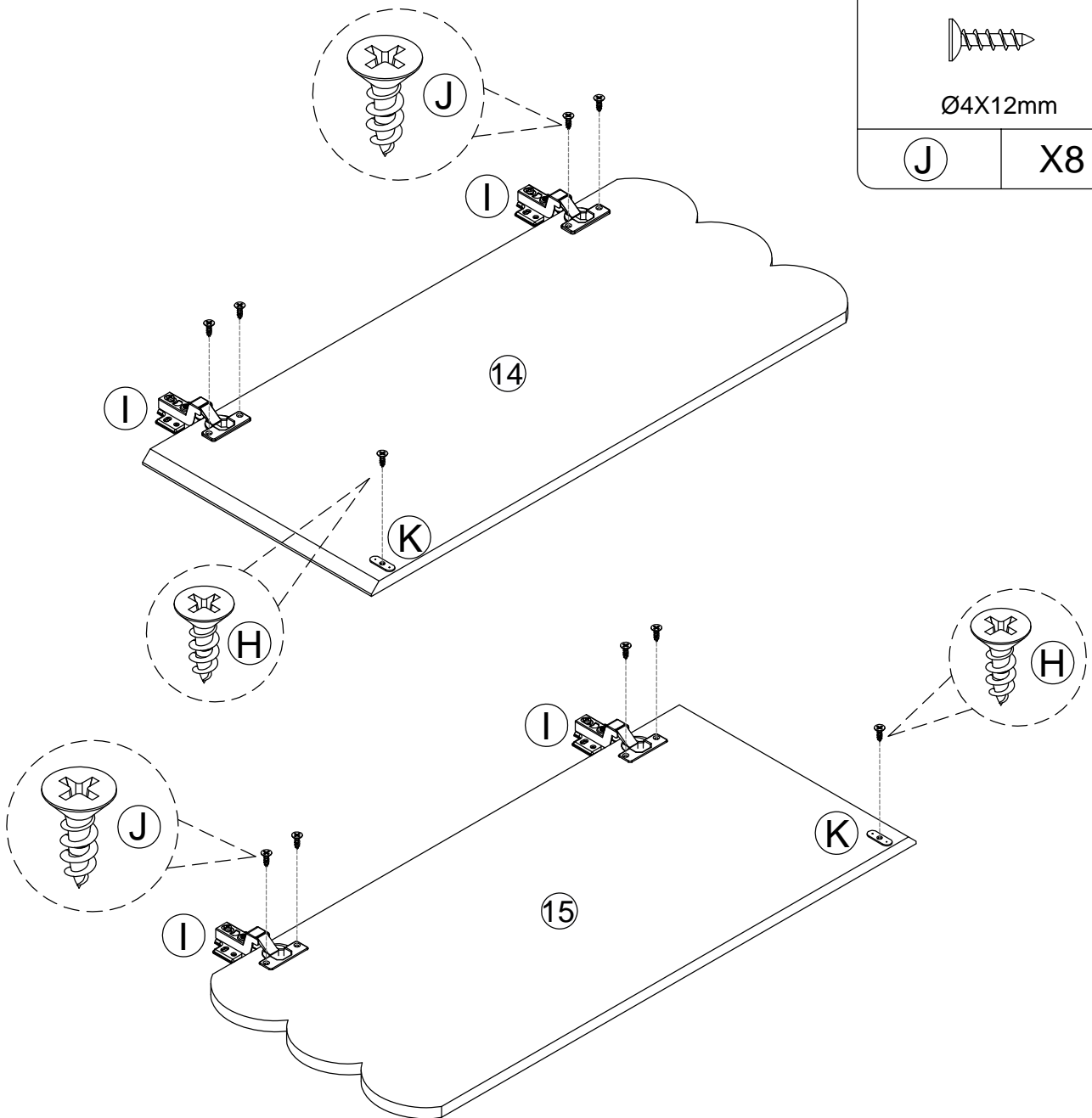
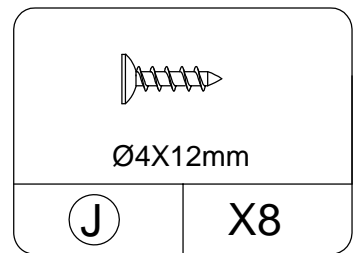
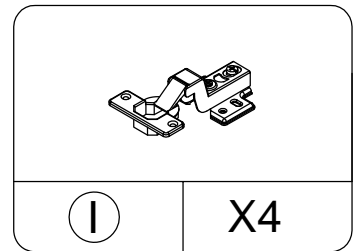
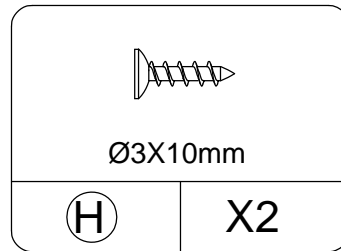
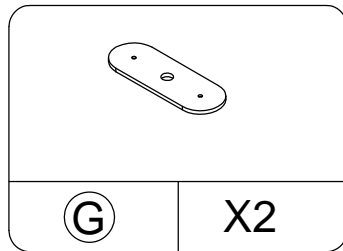
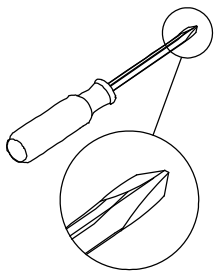

# STEP 15

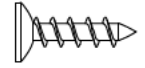

Ø4X12mm

J

X16

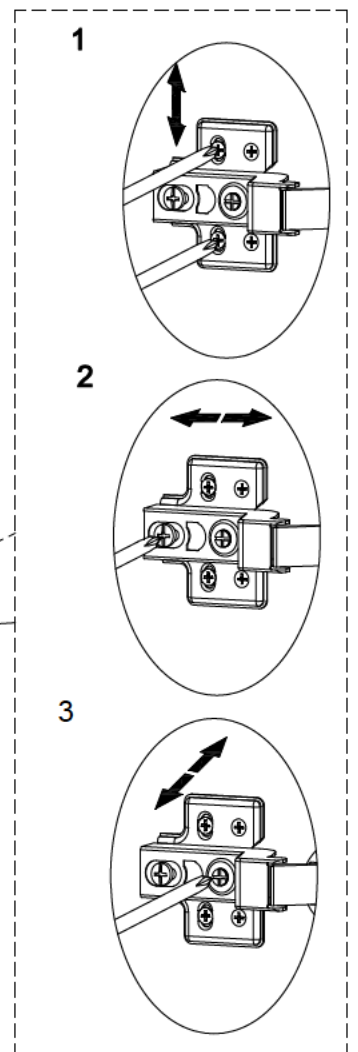
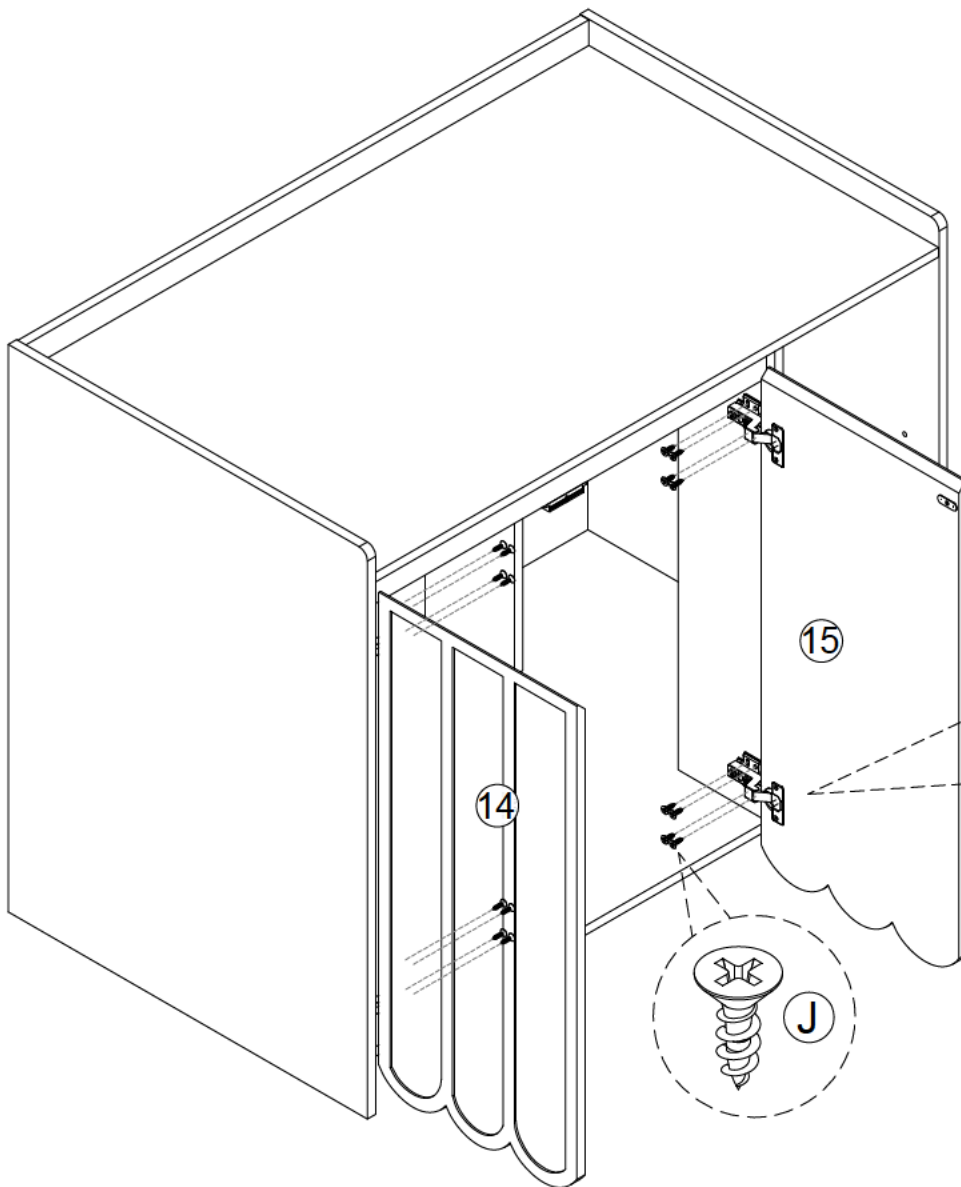

# STEP16

---

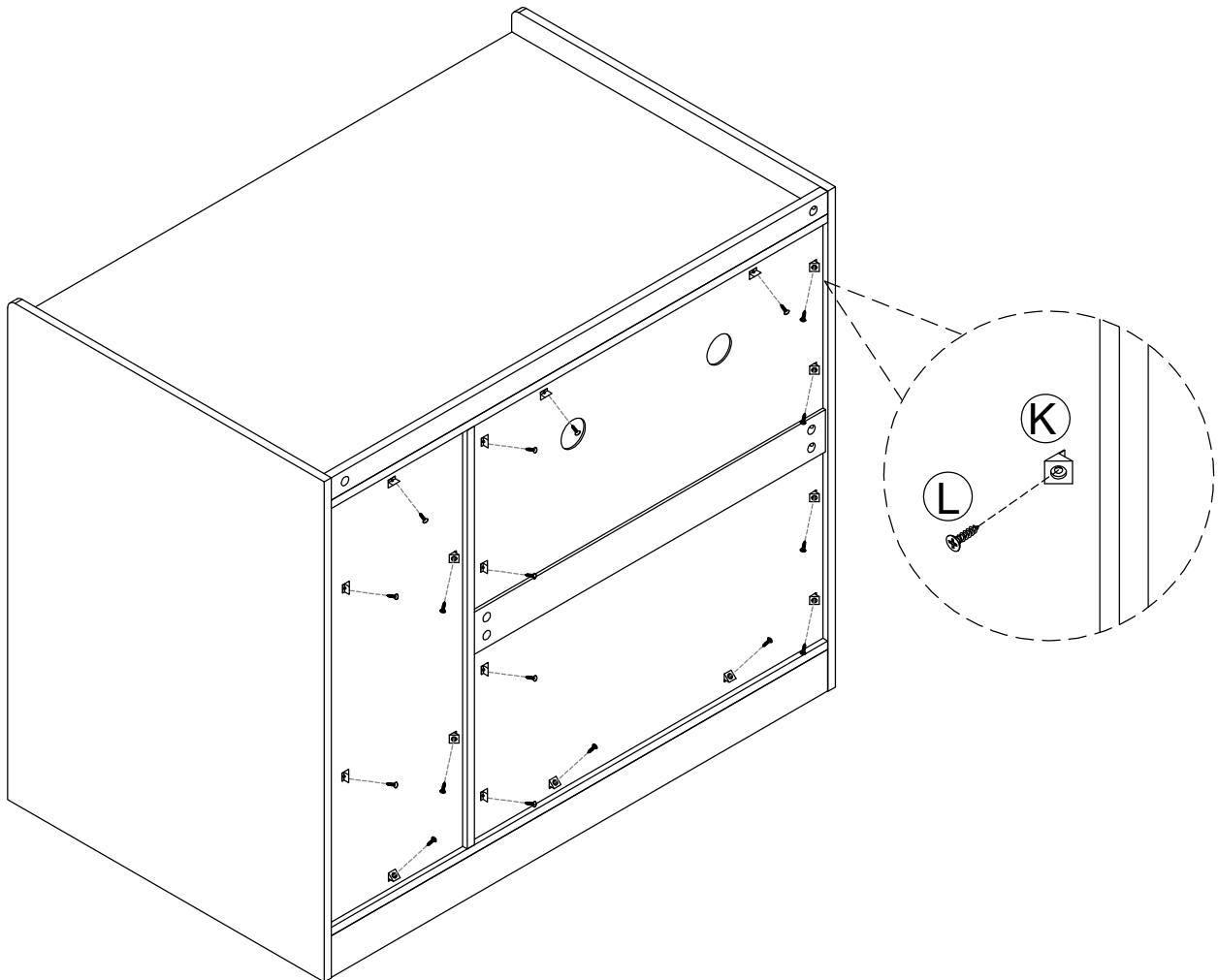
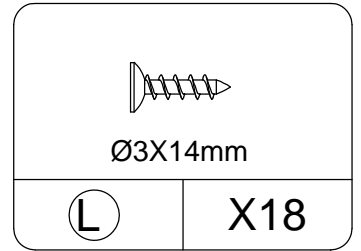
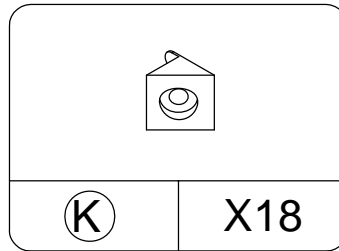

# STEP 17

