



ASSEMBLY INSTRUCTIONS  
*INSTRUCTIONS D'ASSEMBLAGE*  
INSTRUCTIVO DE ARMADO



Article/ Item/ Artículo

Night Stand  
**-060-** *Table de chevet*  
Mesa de noche

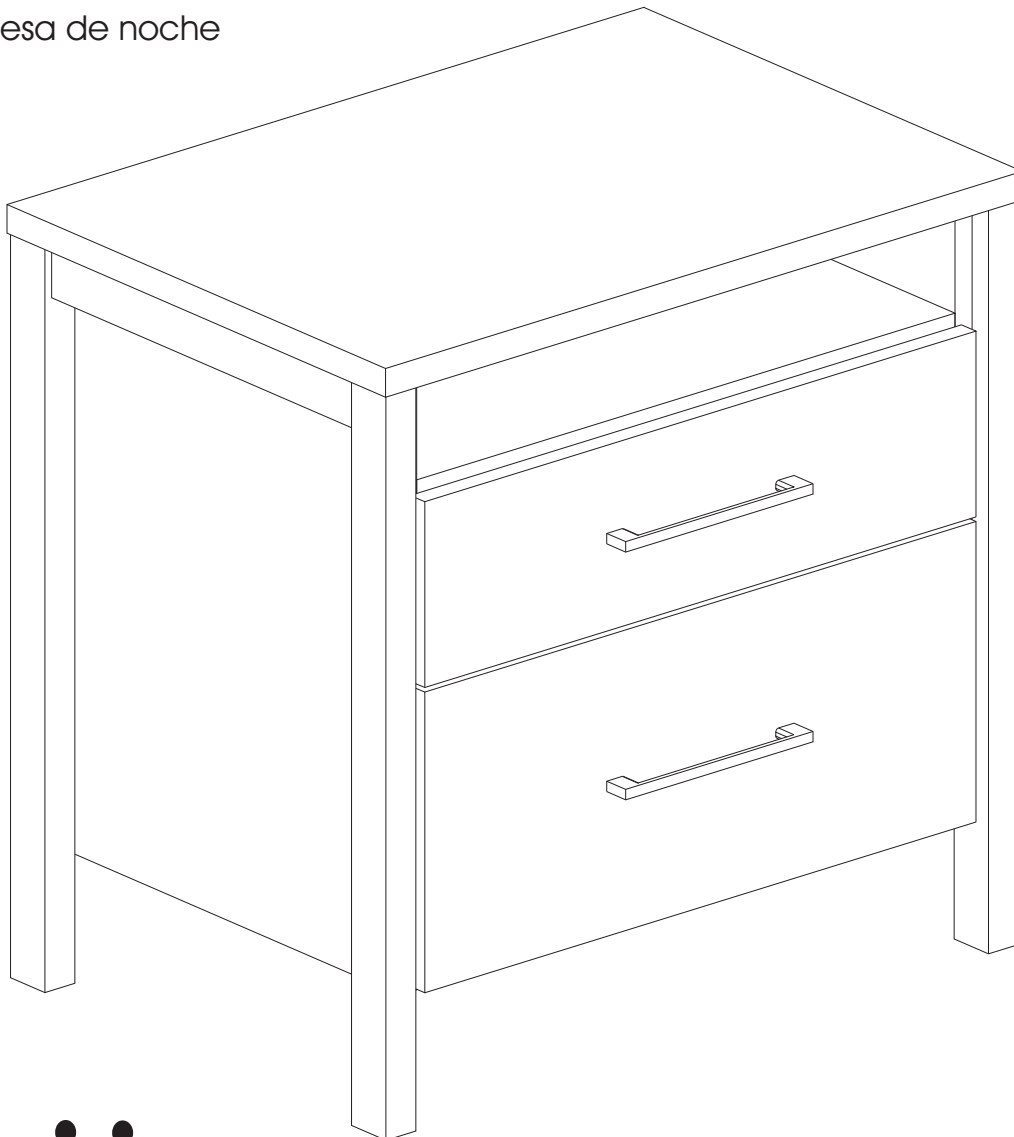

☎ 1-800-290-0465 ☎



ADULT ASSEMBLY REQUIRED  
*DOIT ÊTRE ASSEMBLÉ PAR UN ADULTE*  
DEBE DE SER ARMADO POR UN ADULTO

#Instructions/ #Instructions/ #Instructivo

#10025242

-060-

RIGHT SIDE  
CÔTÉ DROIT  
LADO DERECHO

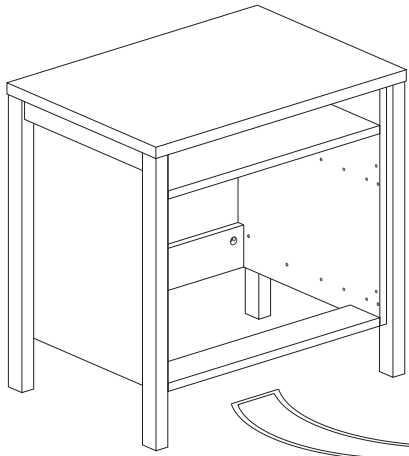

LEFT SIDE  
CÔTÉ GAUCHE  
LADO IZQUIERDO

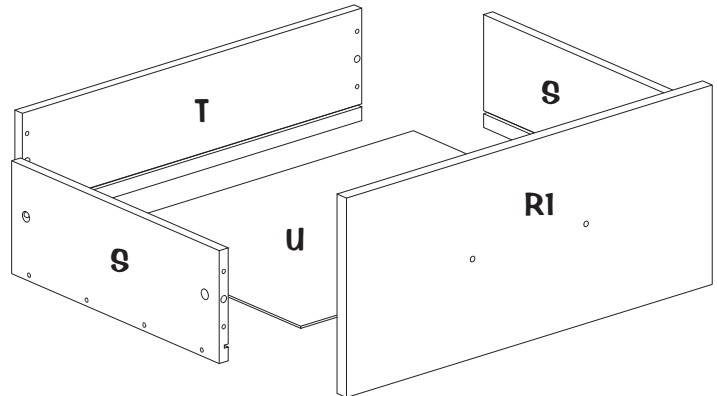
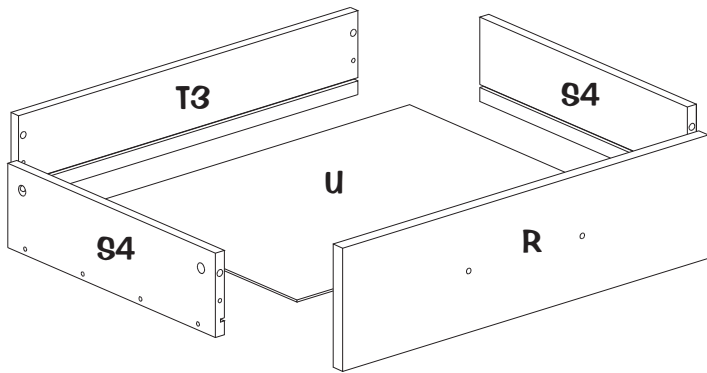
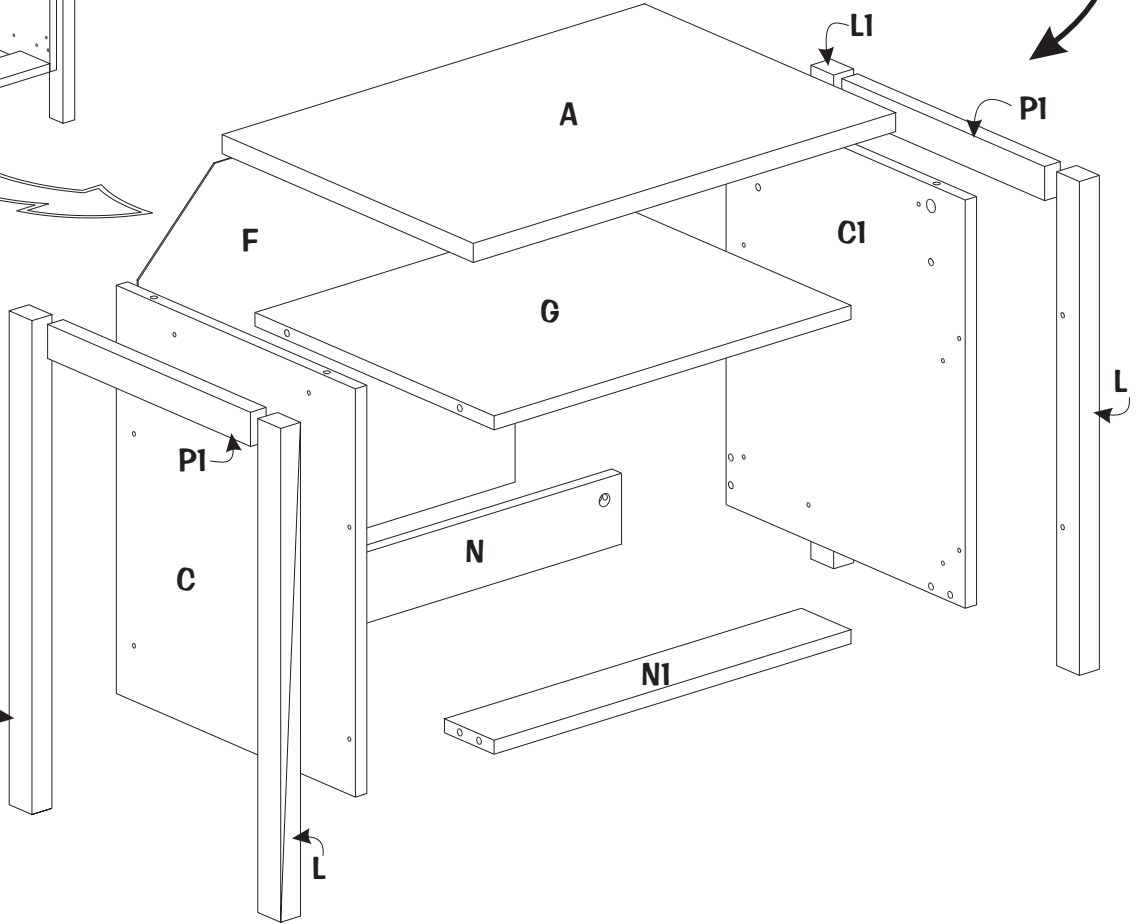

N.B.: It is important to carefully read all instructions before beginning the assembly and before use of the furniture.  
Keep the assembly instructions for future use and for warranty purposes.

N.B. Il est important de bien lire toutes les instructions avant de commencer l'assemblage et avant d'utiliser le meuble.  
Gardez les instructions d'assemblage pour utilisation future et pour la garantie.

N.B. Lea con detenimiento las instrucciones antes de comenzar a ensamblar y antes de utilizar su mueble.  
Guarde el instructivo de ensamble para un futuro uso y para usos de garantía.

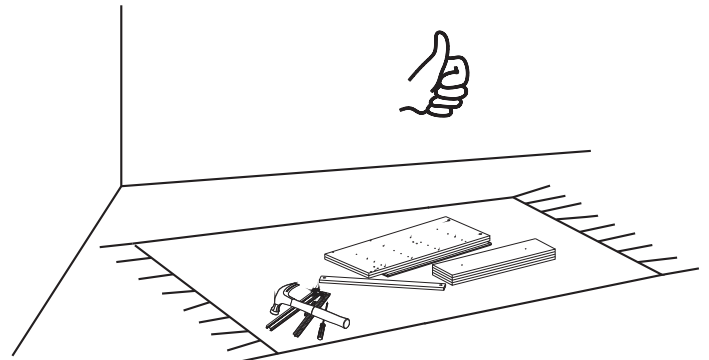
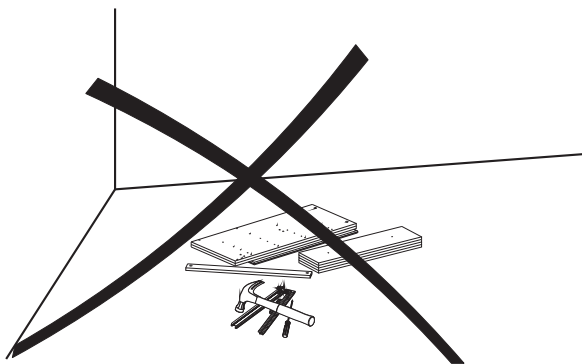
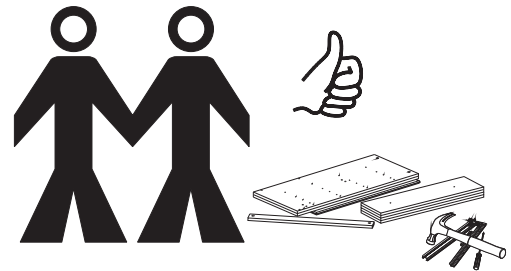

\* TOOLS REQUIRED/OUTILS REQUIS/HERRAMIENTAS REQUERIDAS:

- HAMMER/MARTEAU/MARTILLO

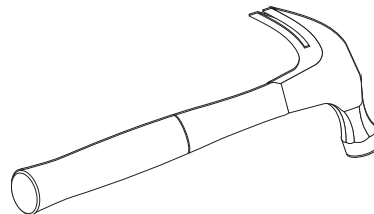

- STANDARD/PLAT/PLANO

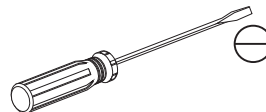

- PHILLIPS/ÉTOILE/CRUZ

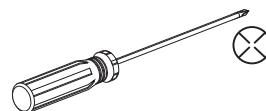





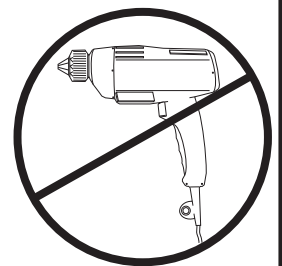
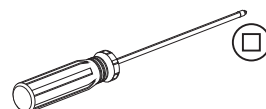





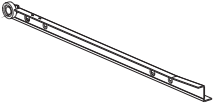

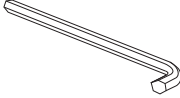
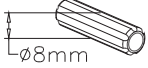
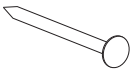
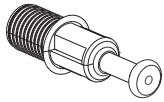
or/ou/o

- ROBERTSON/CARRÉ/CUADRADO

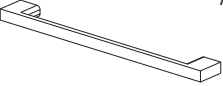

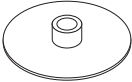
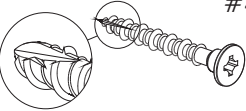
# HARDWARE / QUINCAILLERIE / FERRETERÍA

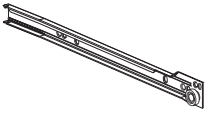
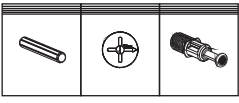
4X	 #6	4X	 #121	4X	 #208
8X	 #87	1X	 #131	8X	 #231
16X	 #90	8X	 #144	8X	 #393
16X	 #92	8X	 #158	2X	 #408
2X	 #99	4X	 #171	4X	 #414
4X	 #109	4X	 #207	2X	 #516

\* Hardware package may have spare parts .

\* Le sac de quincaillerie peut contenir des pièces de remplacement .

\* La bolsa de herraje puede contener piezas adicionales de repuesto .

# 1

4X

#92



2X

#207

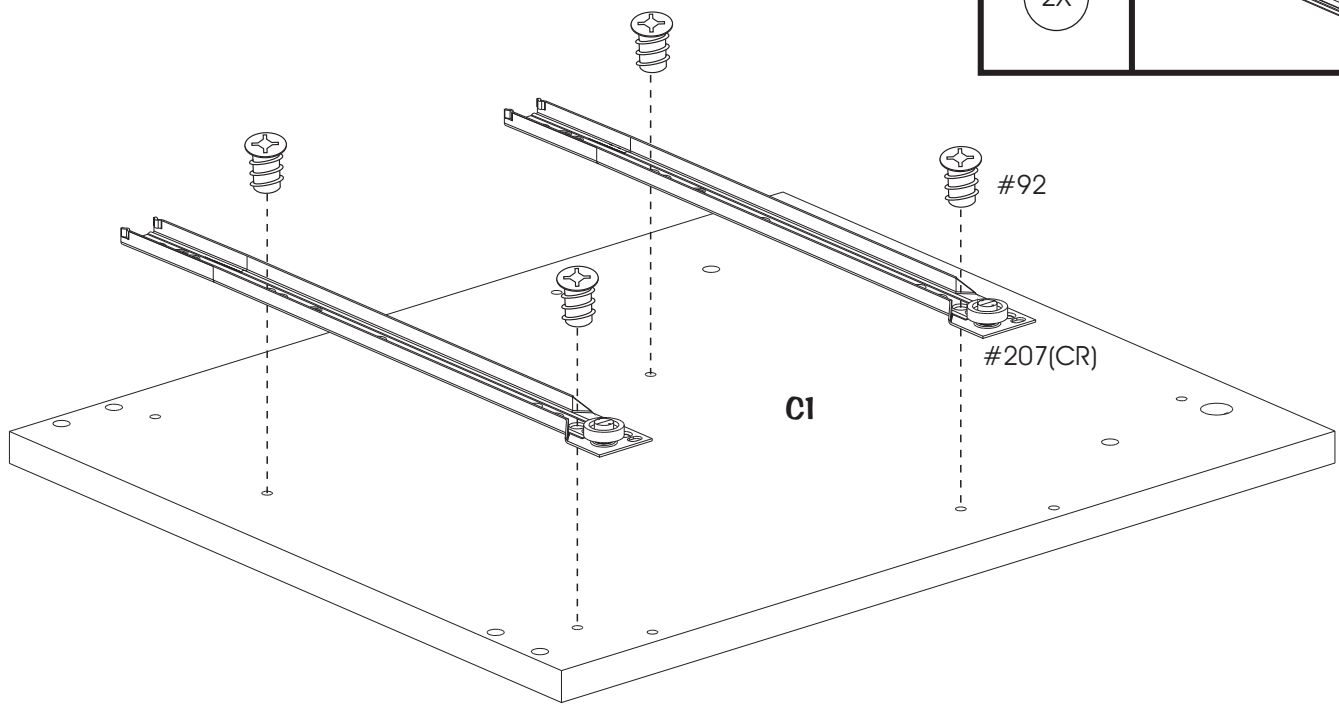
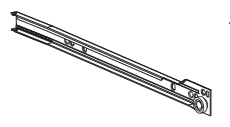

# 2

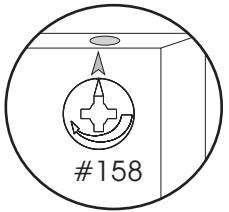

#158

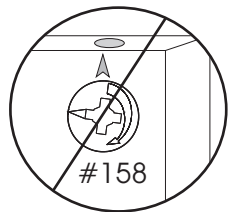

#158



2X

#144

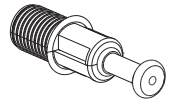

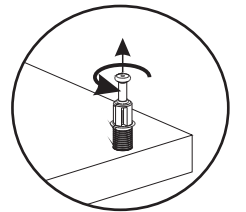
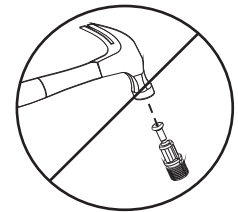
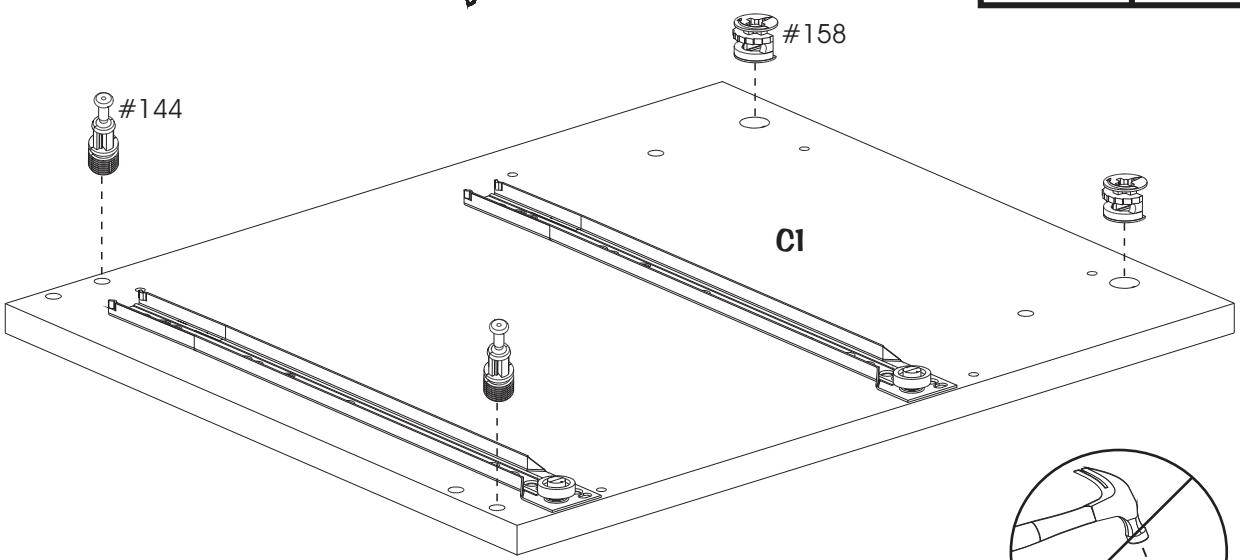
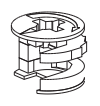

2X

#158

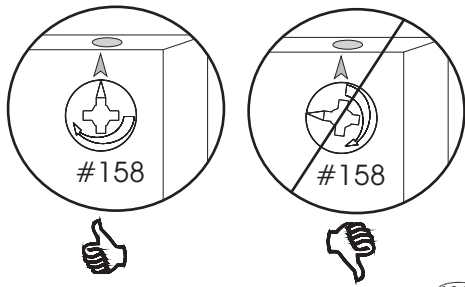

# 3

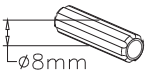

4X	 #158
8X	 #231 ∅8mm

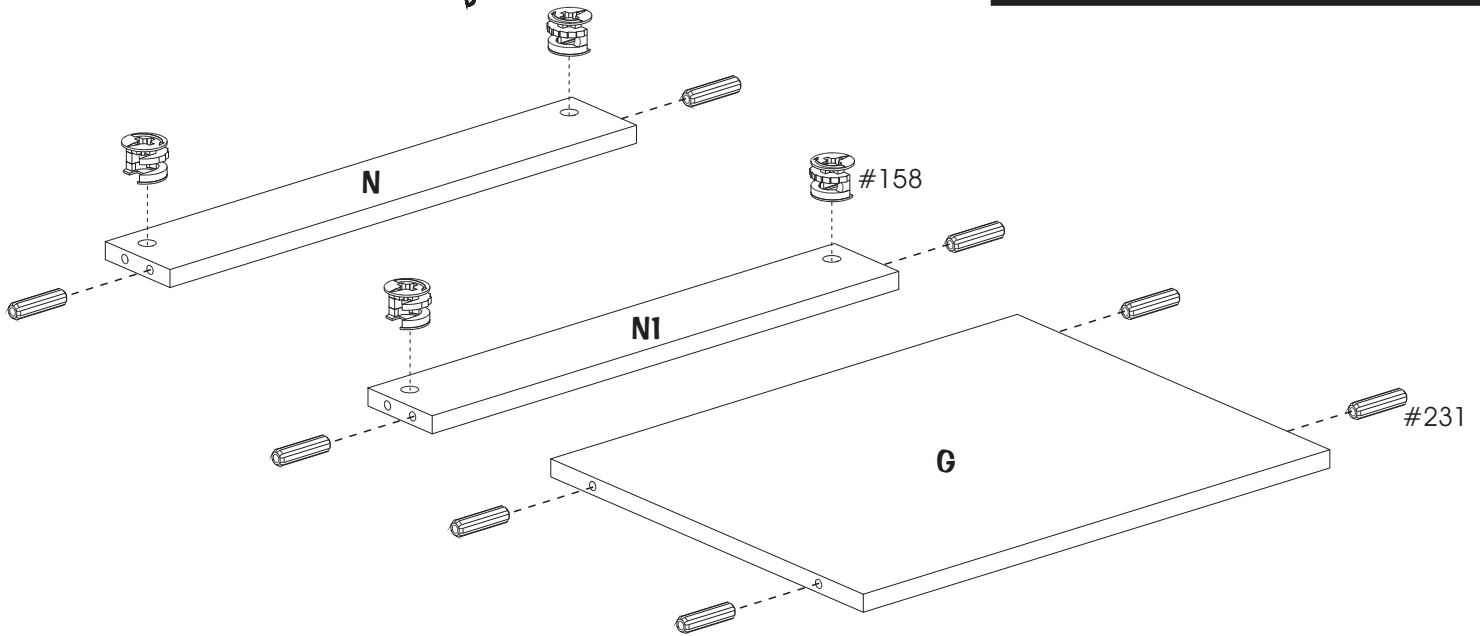

# 4

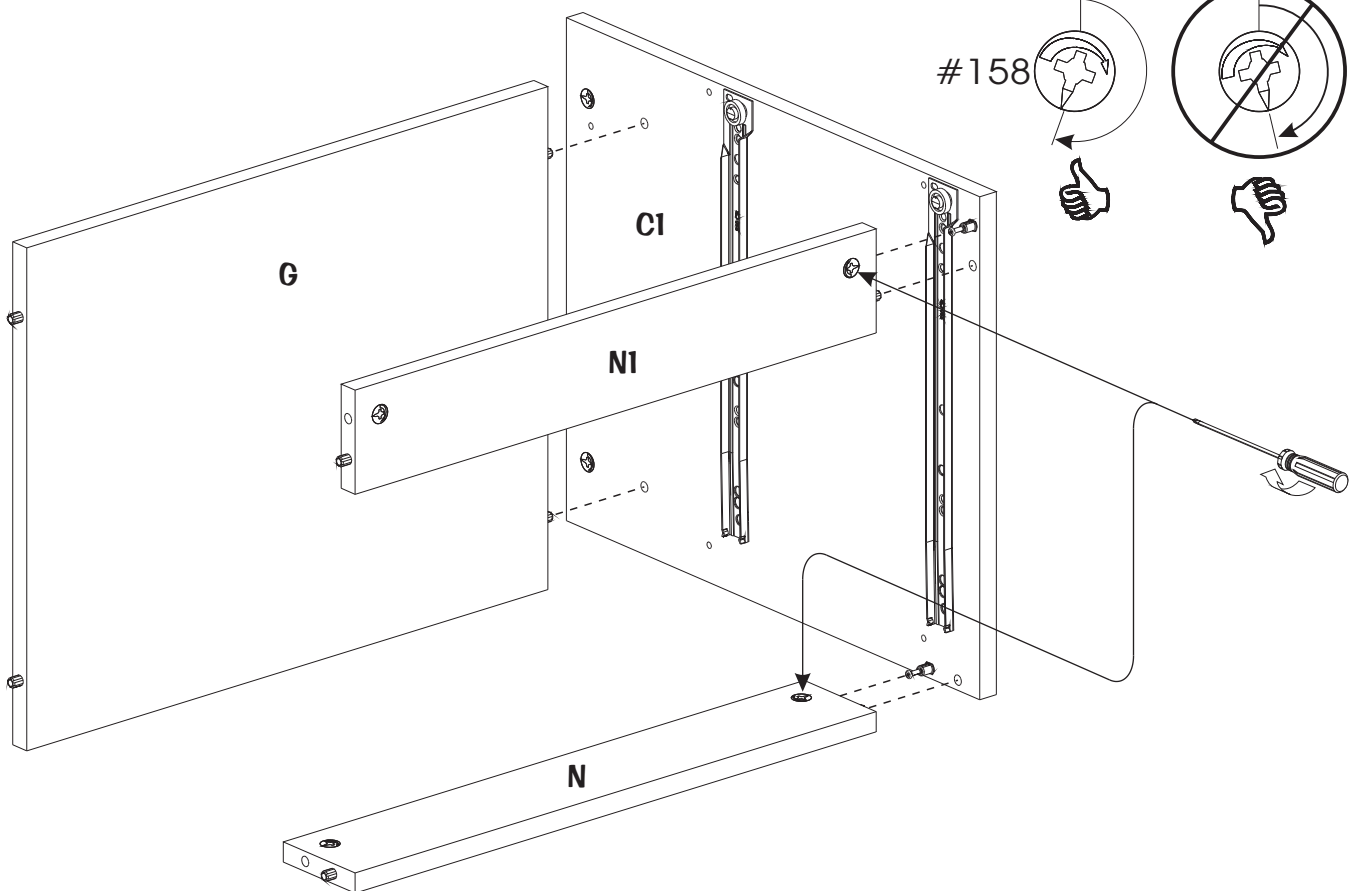
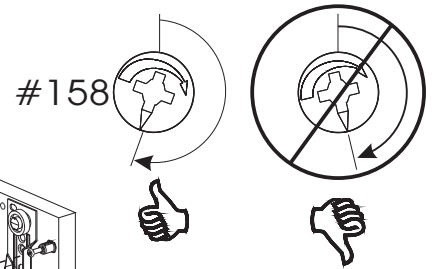

# 5

4X

#92



2X

#207

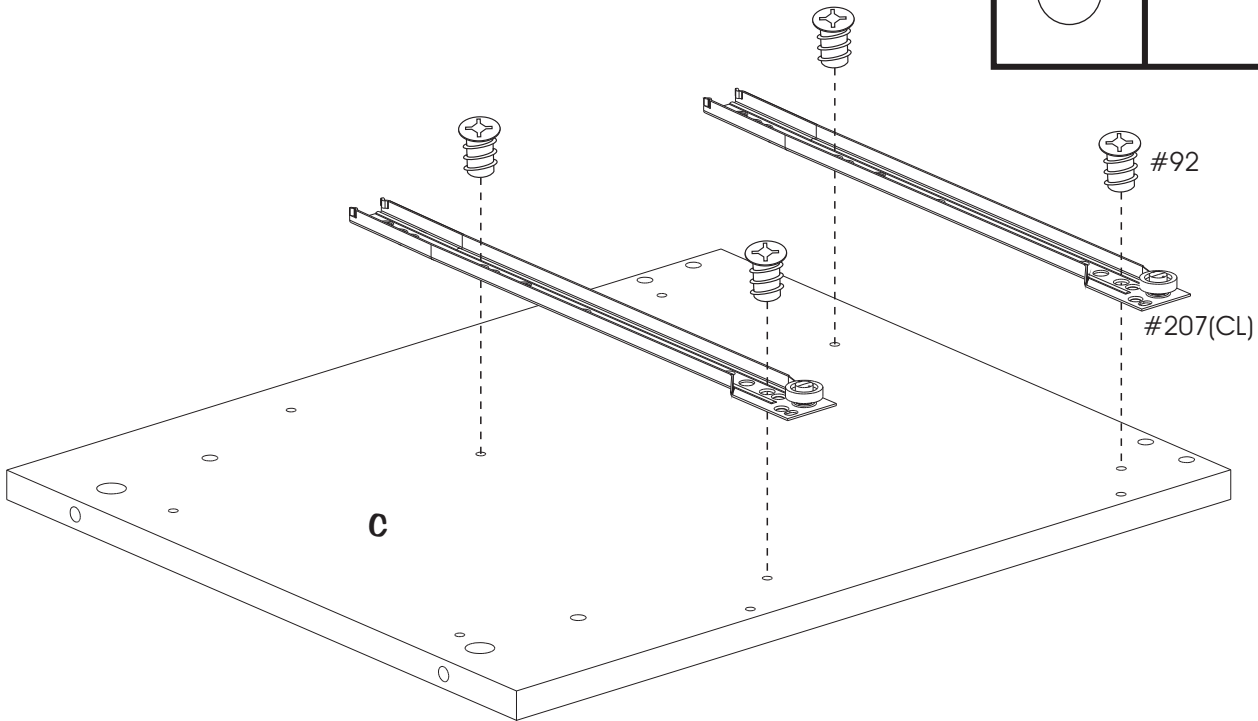
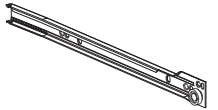

# 6

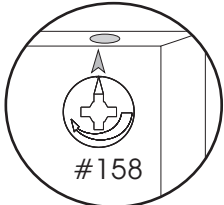

#158

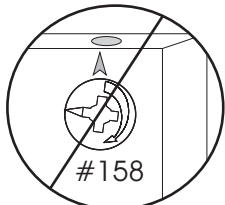

#158



2X

#144

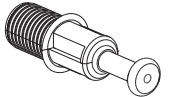

2X

#158

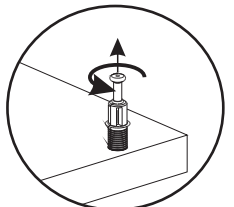
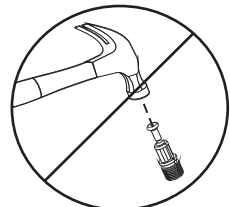
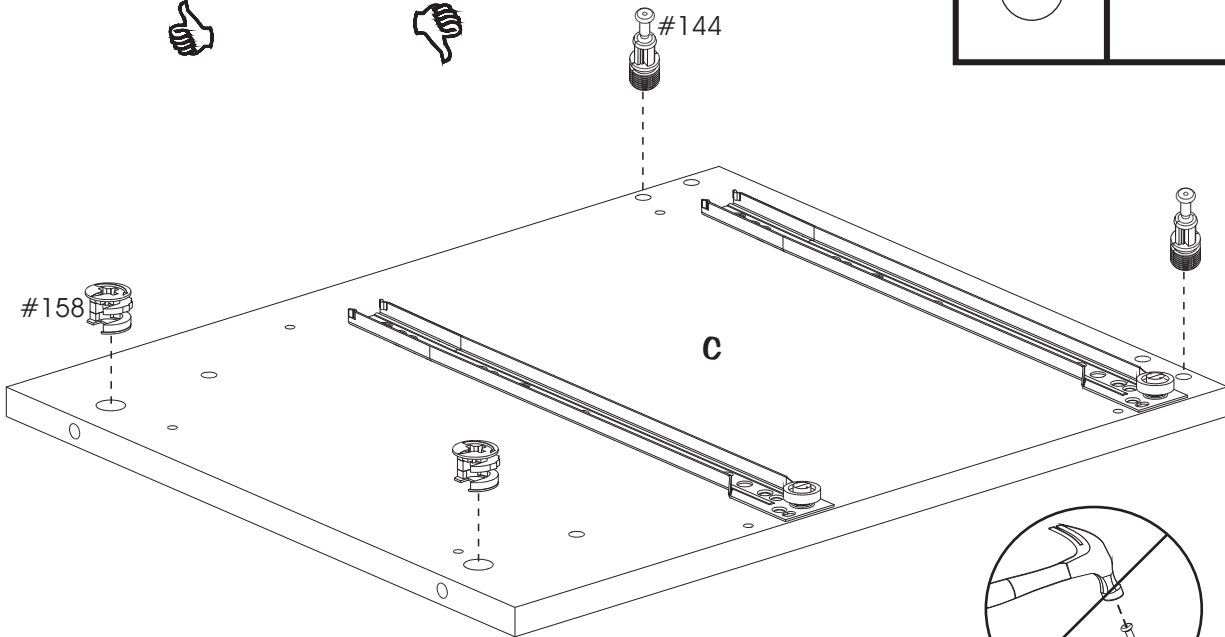

# 7

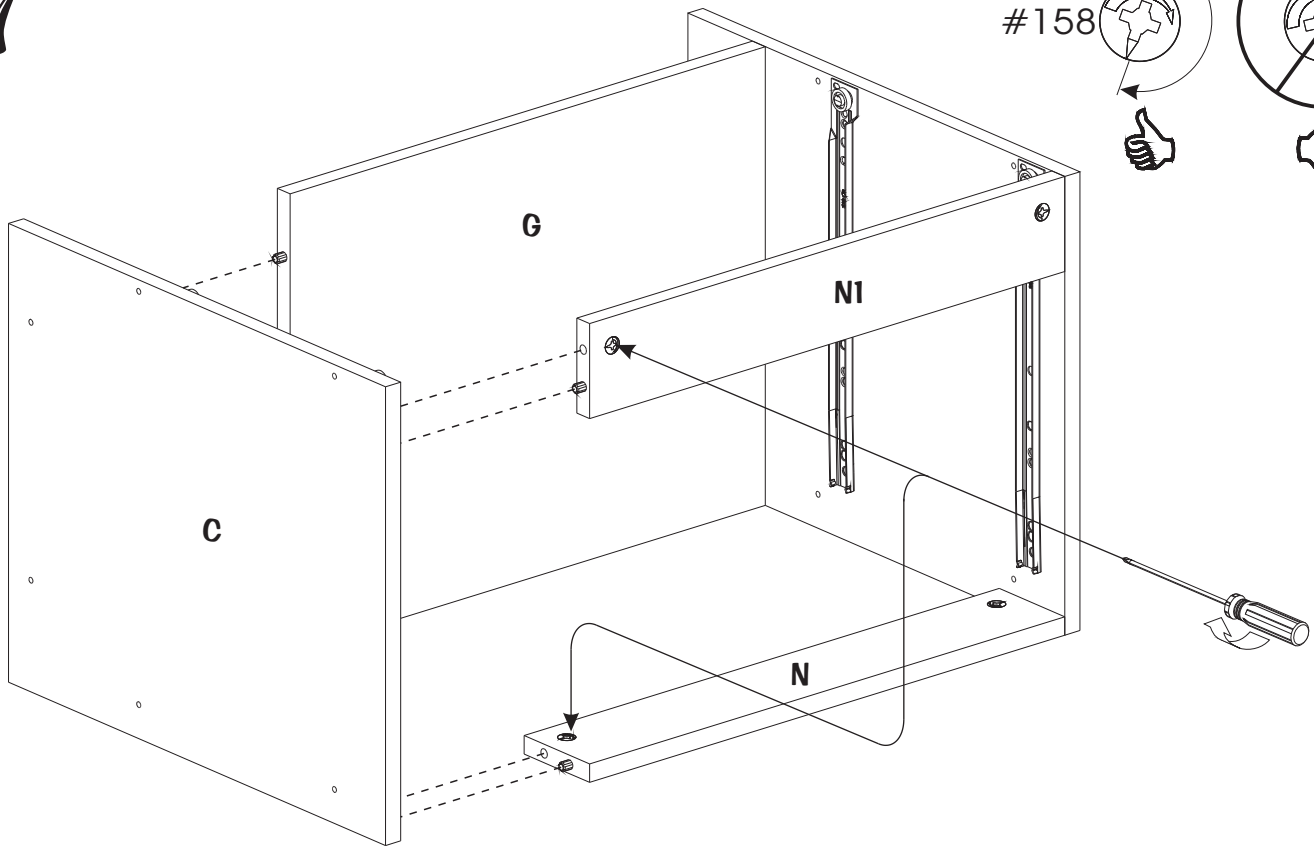

#158

# 8

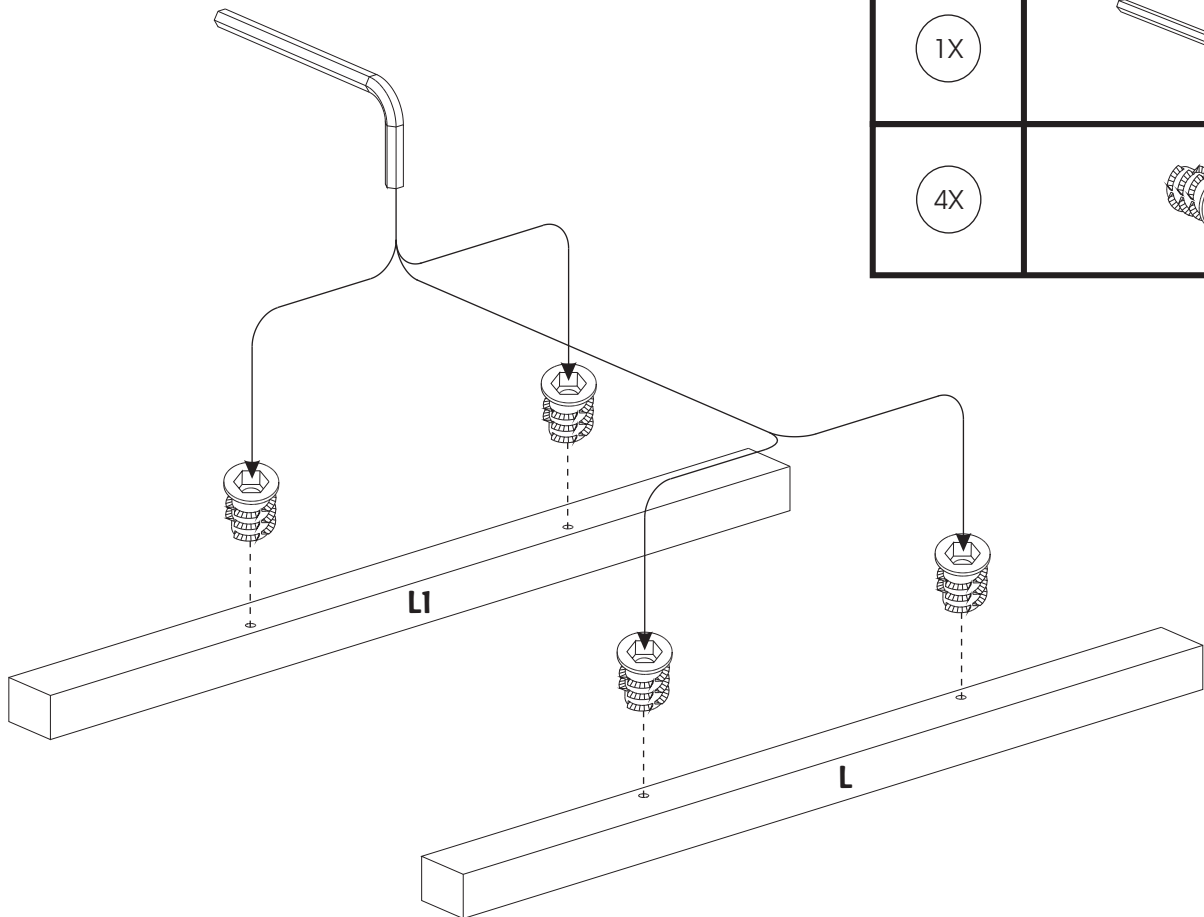

1X

#131

4X

#393

# 9

4X

#87

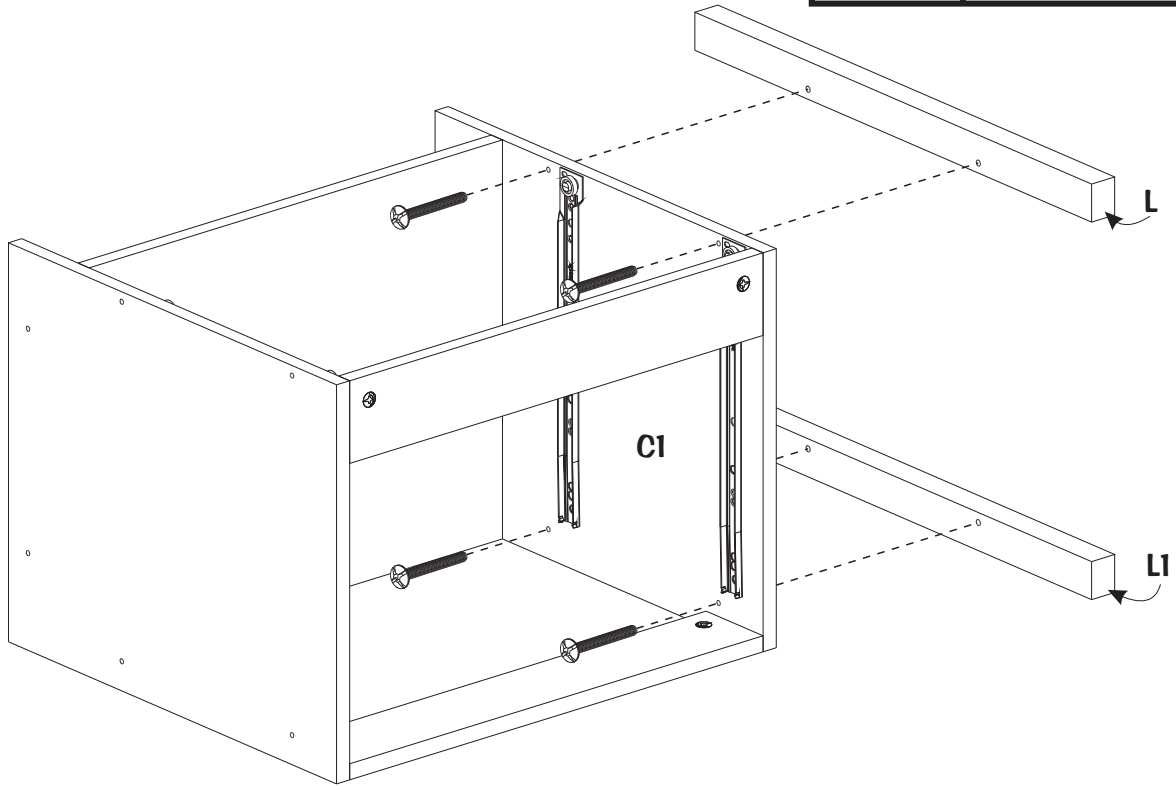
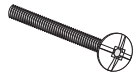

# 10

2X

#414

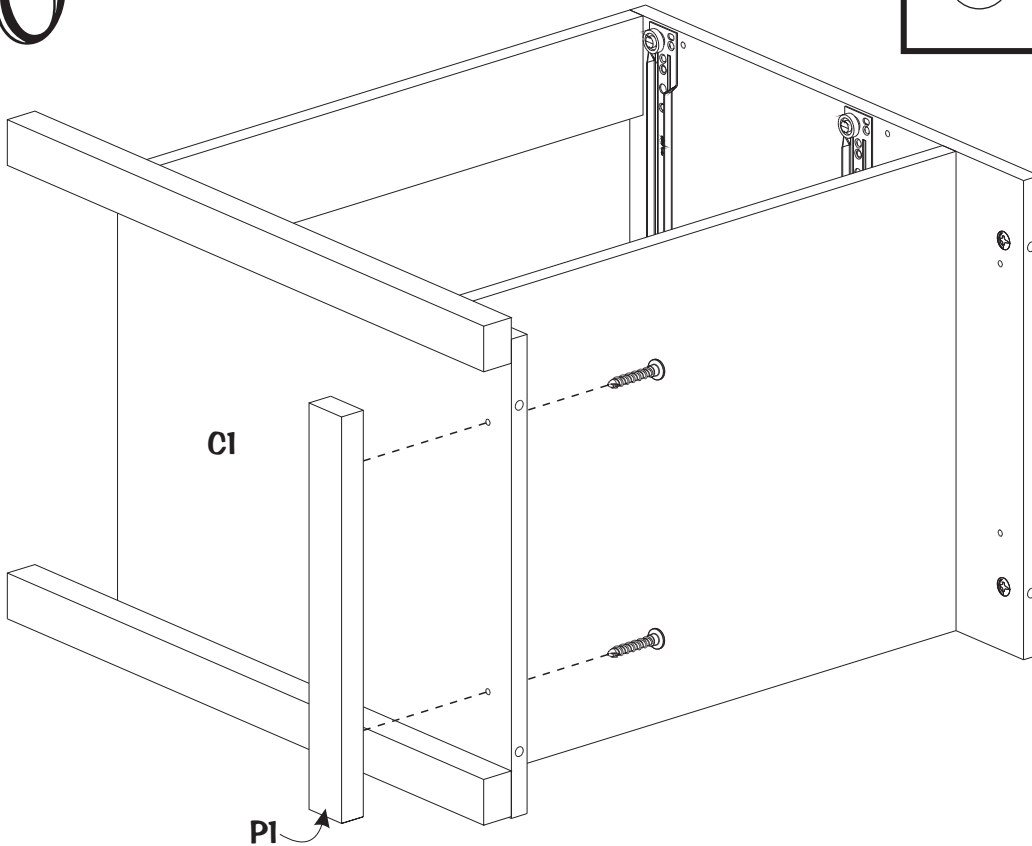
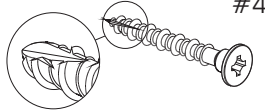

# 11

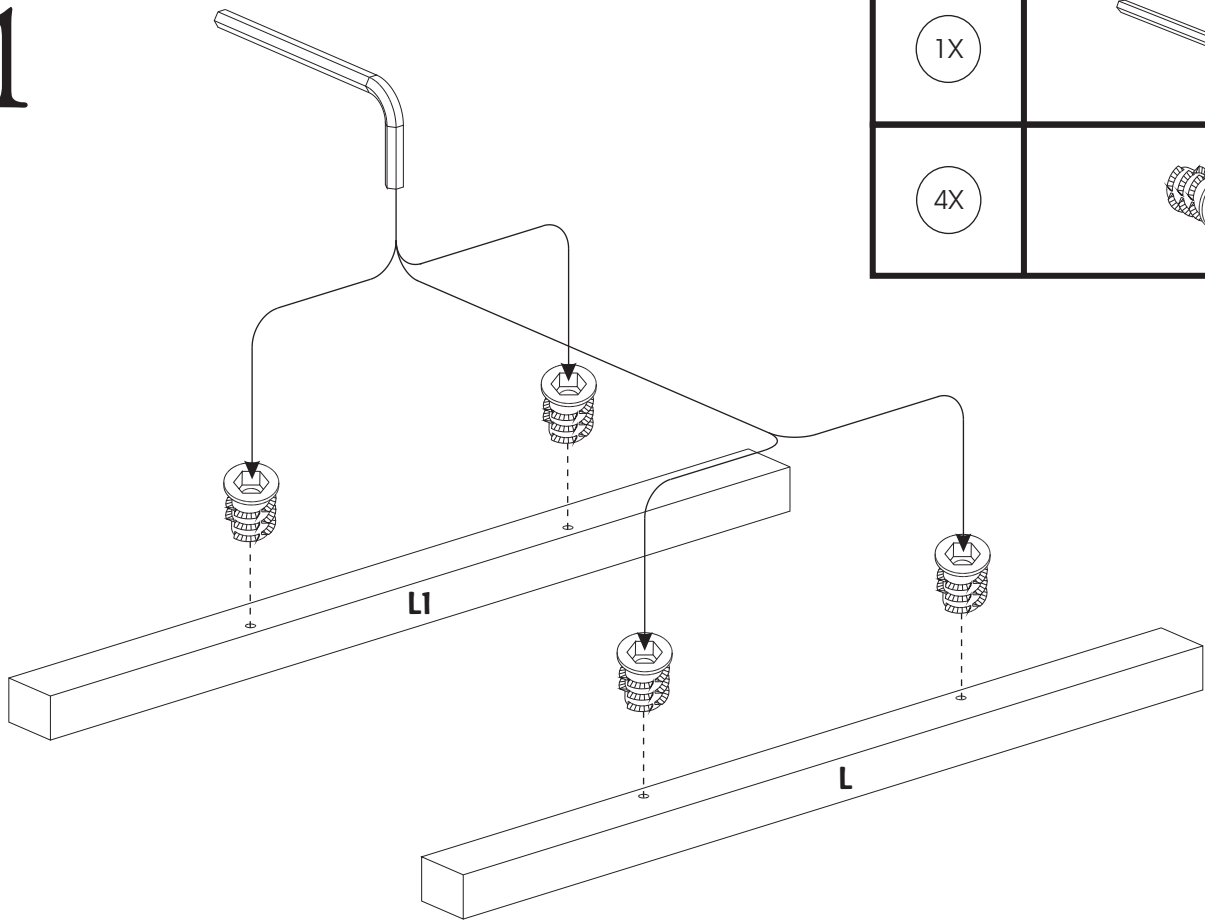

1X

#131

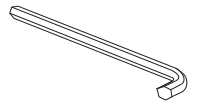

4X

#393



# 12

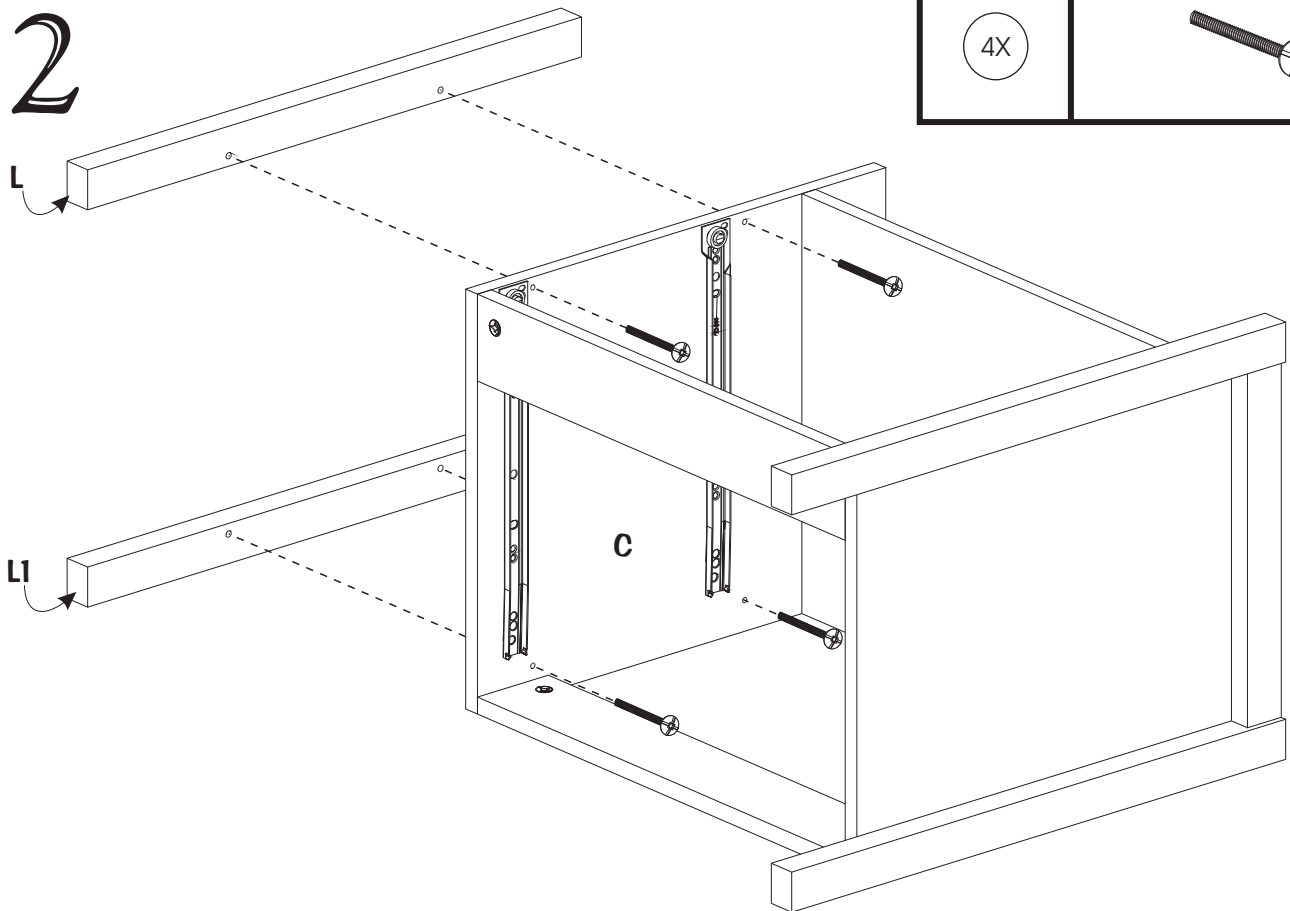

4X

#87

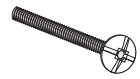

# 13

2X

#414

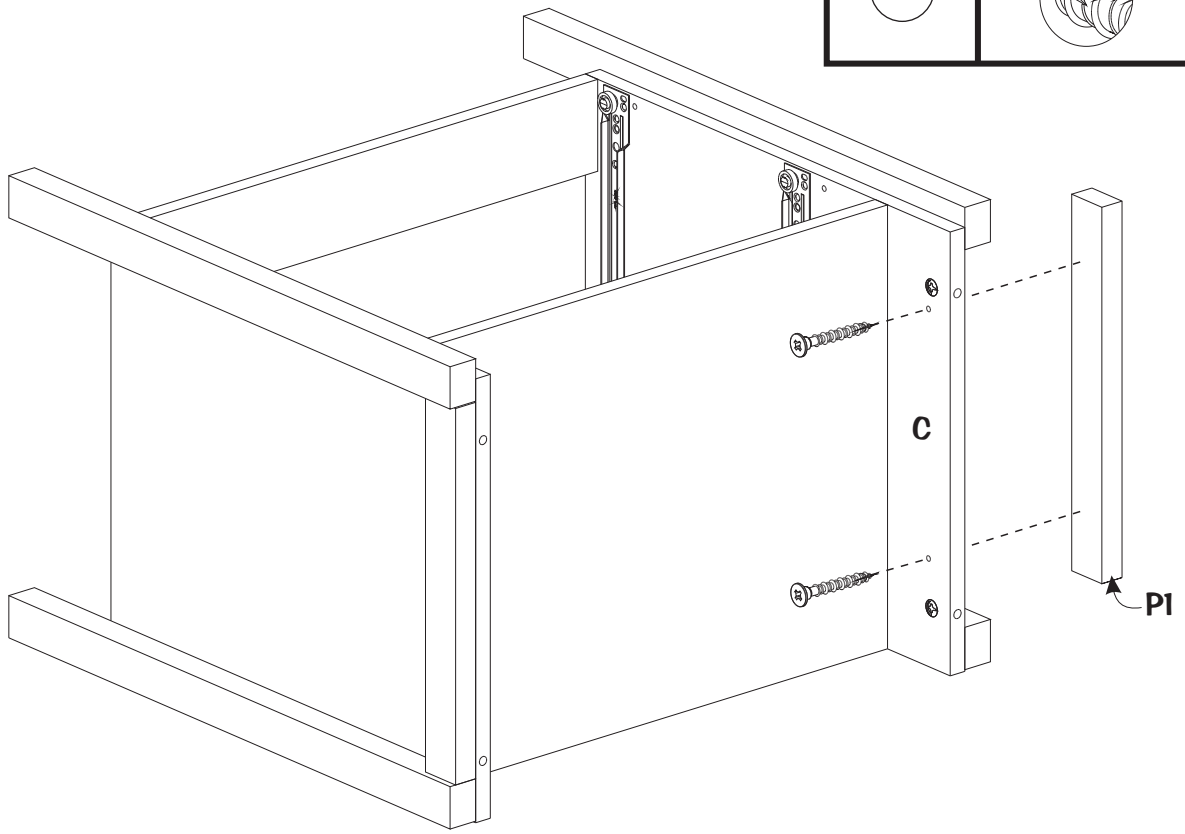
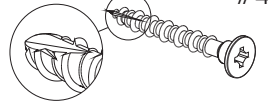

# 14

4X

#144

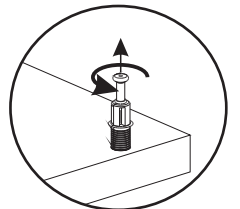
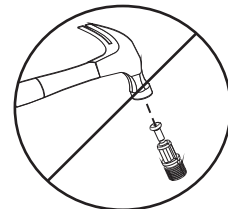
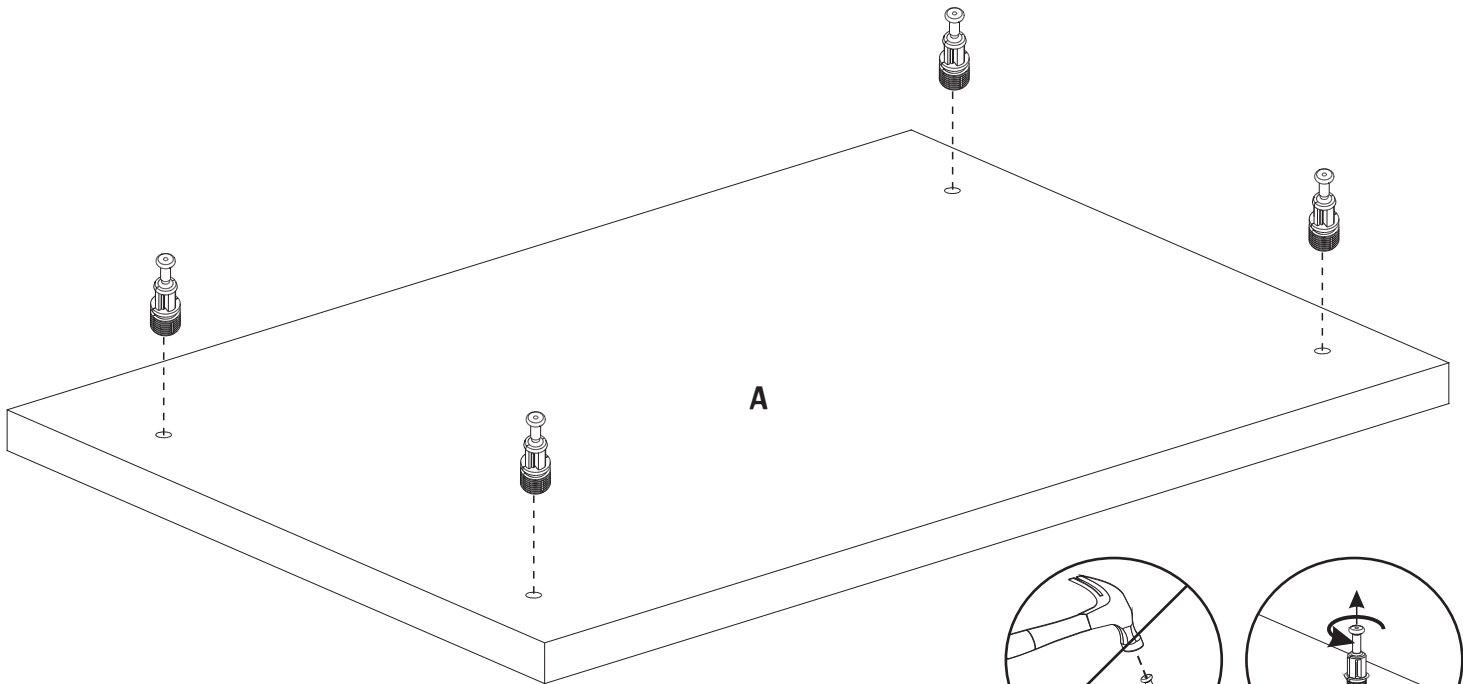
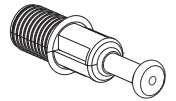



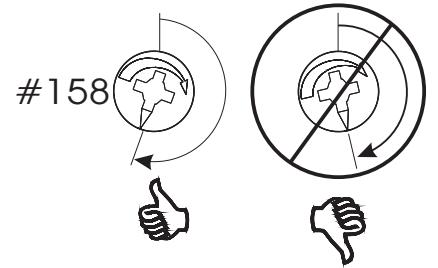
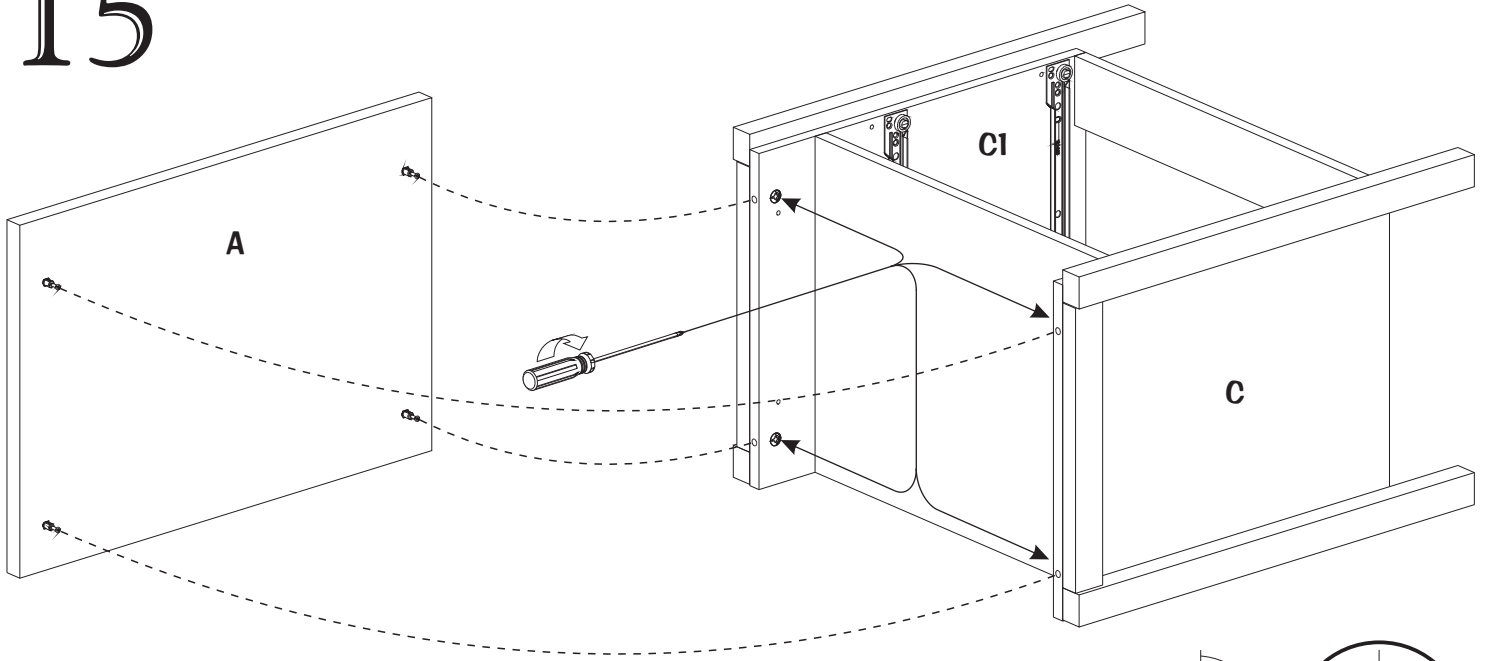

# 15

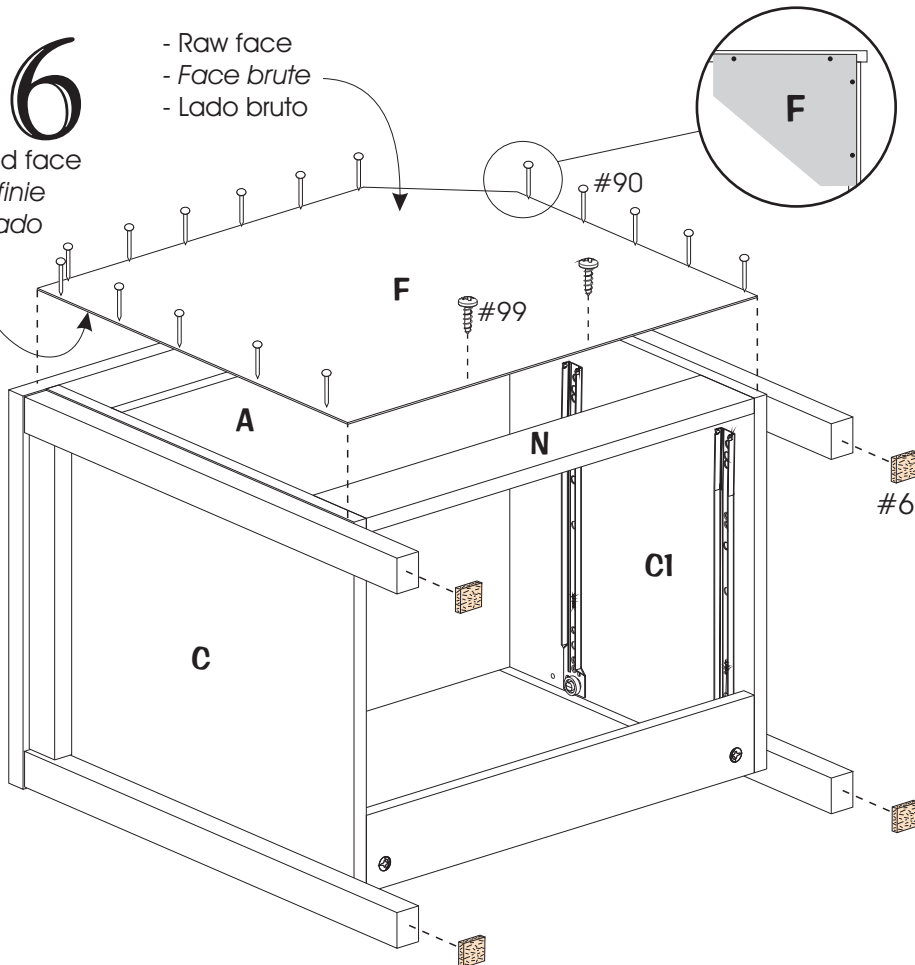

# 16

- Raw face
  - Face brute
  - Lado bruto
- finished face
  - Face finie
  - Acabado

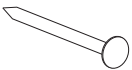

4X		#6
16X		#90
2X		#99

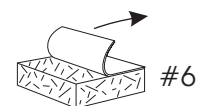

Pull the paper off.  
**Enlever le papier.**  
 Quitar el papel.

**-516-**

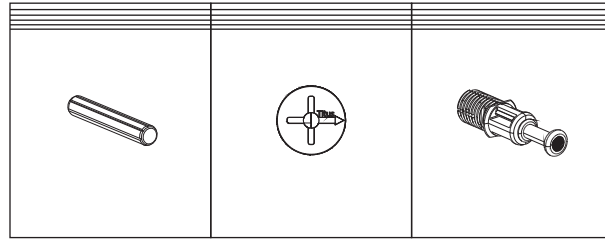

Each contain  
Chacun contient  
Cada uno contiene

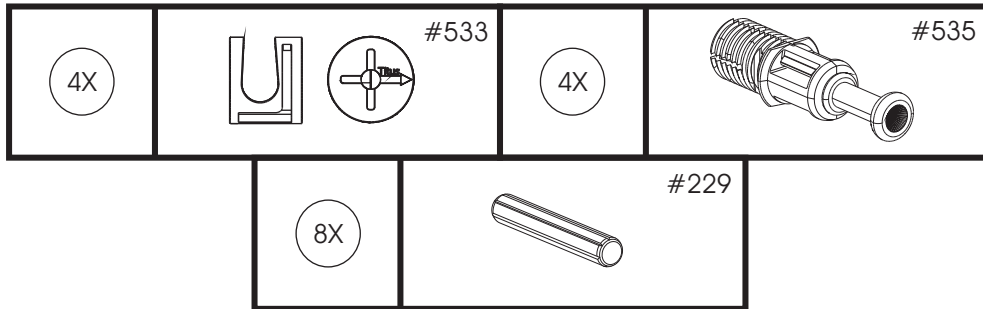

17

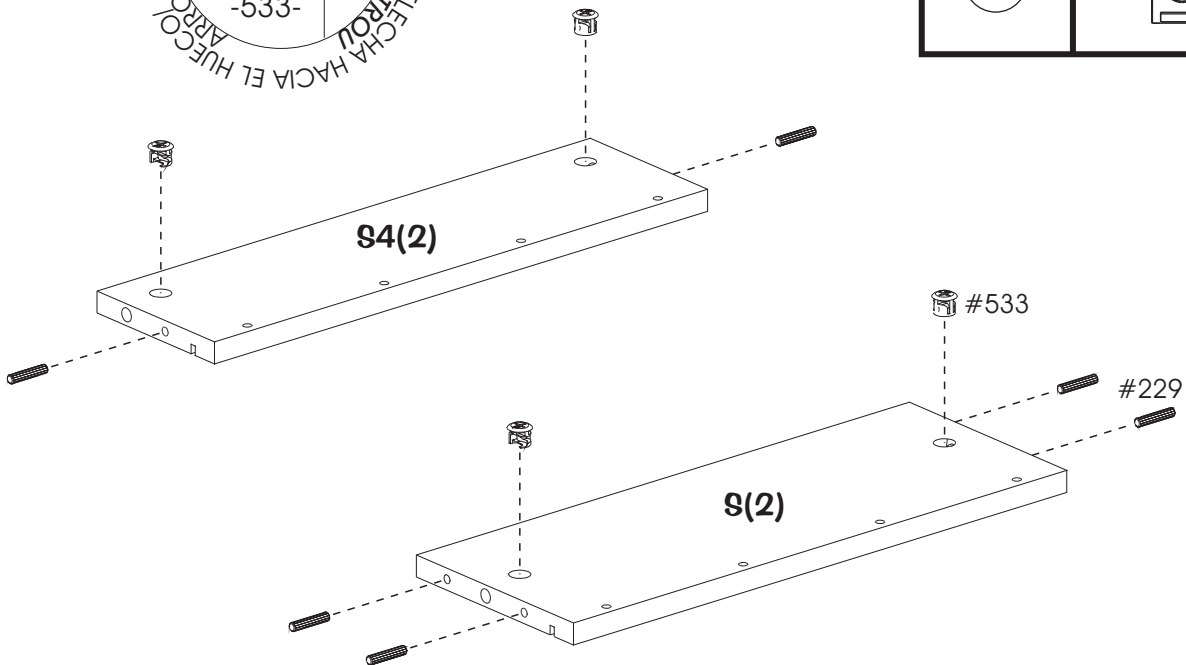
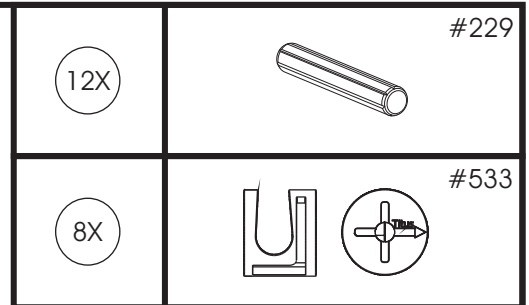

# 18

8X

#535

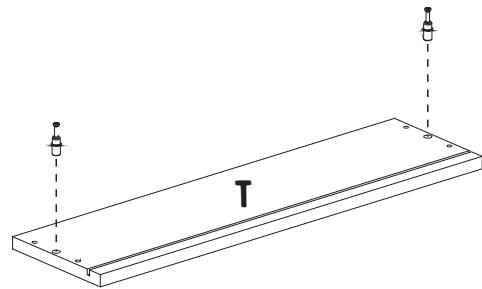
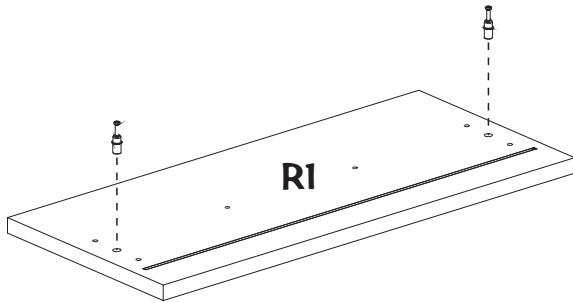
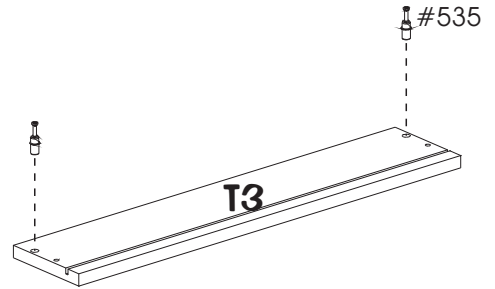
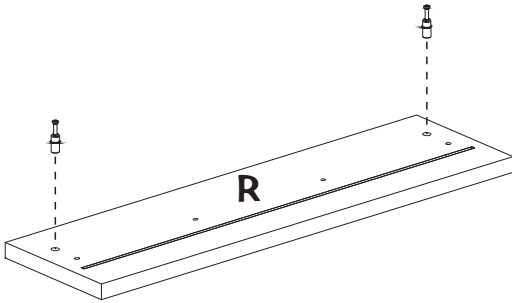
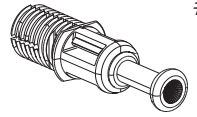

# 19

-533-



correct/  
correcto

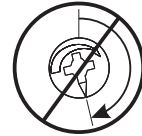

incorrect/  
incorrecto

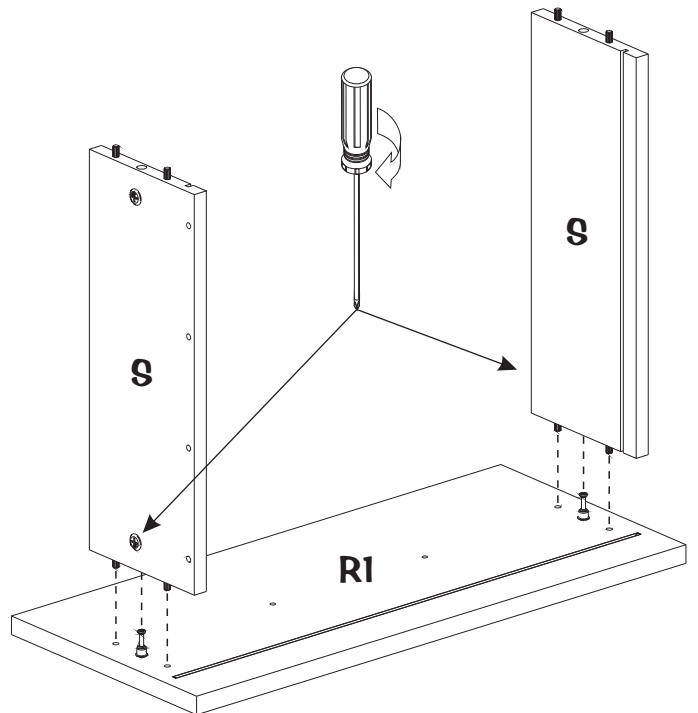
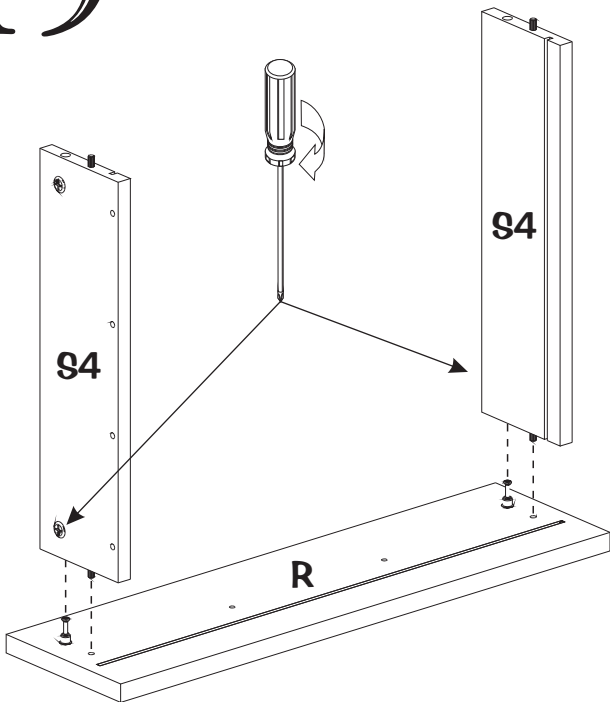

# 20

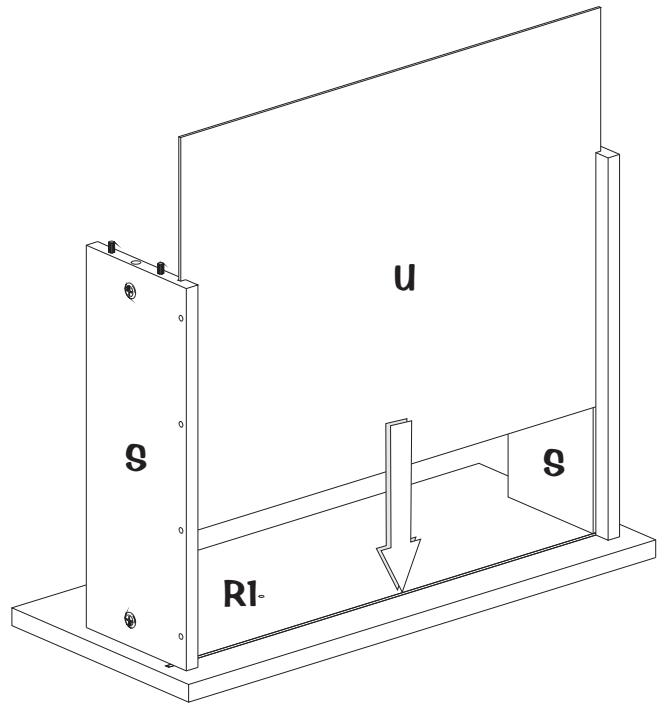
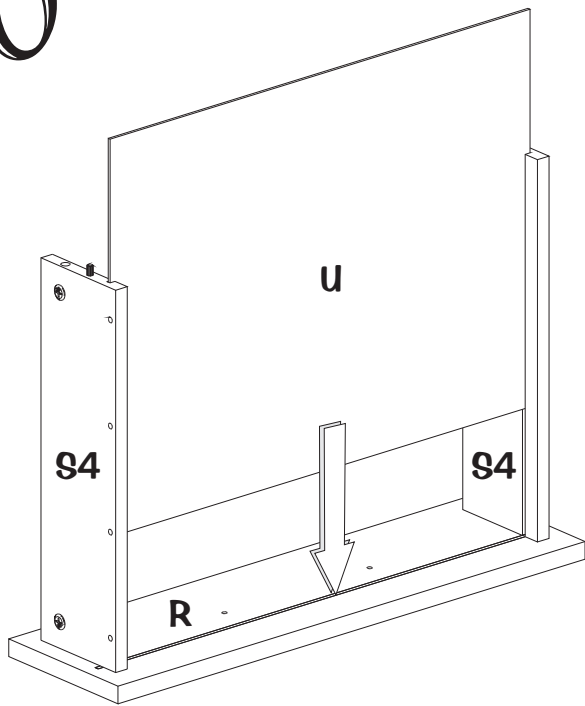

# 21

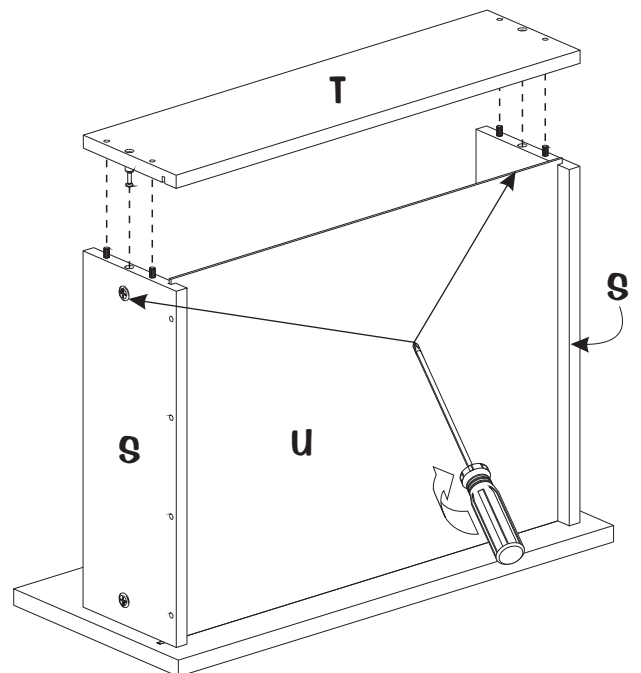
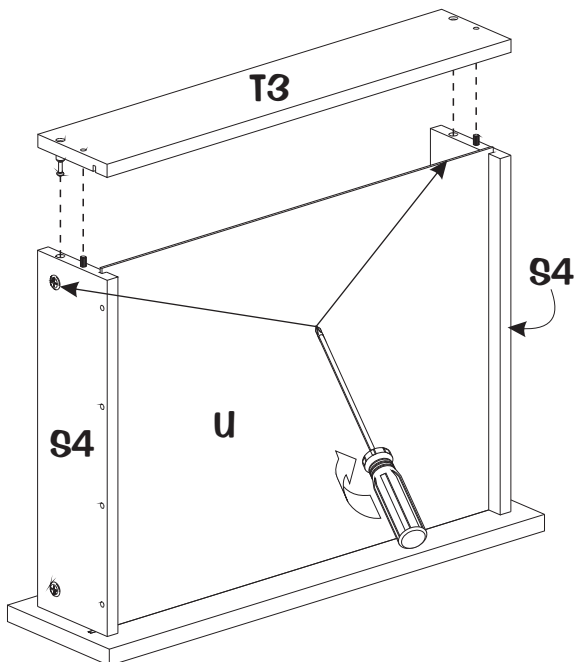
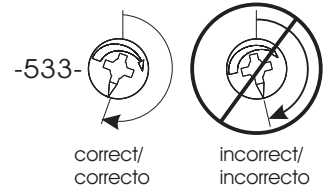

# 22

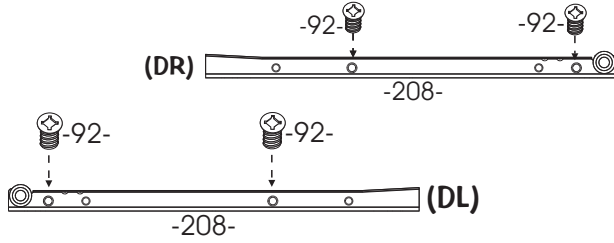

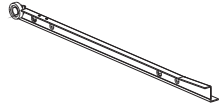

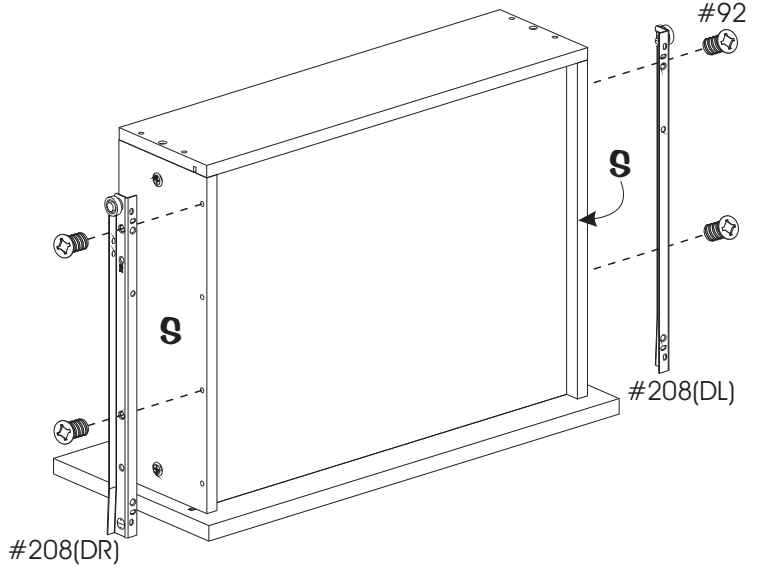
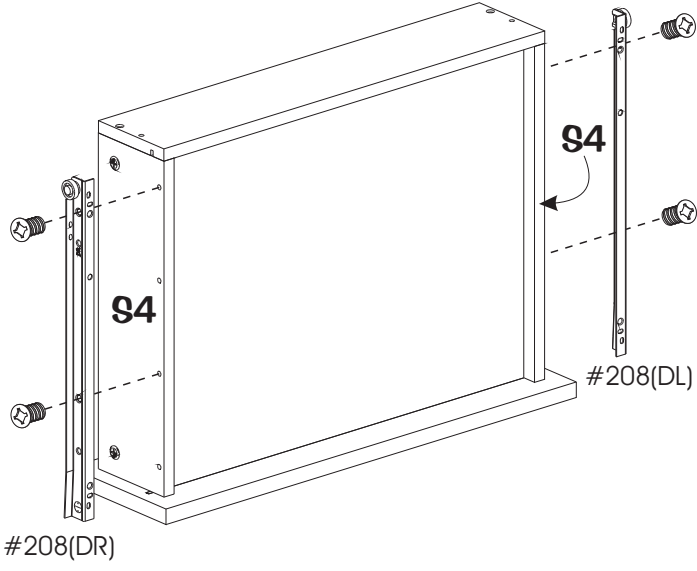
8X		#92
4X		#208

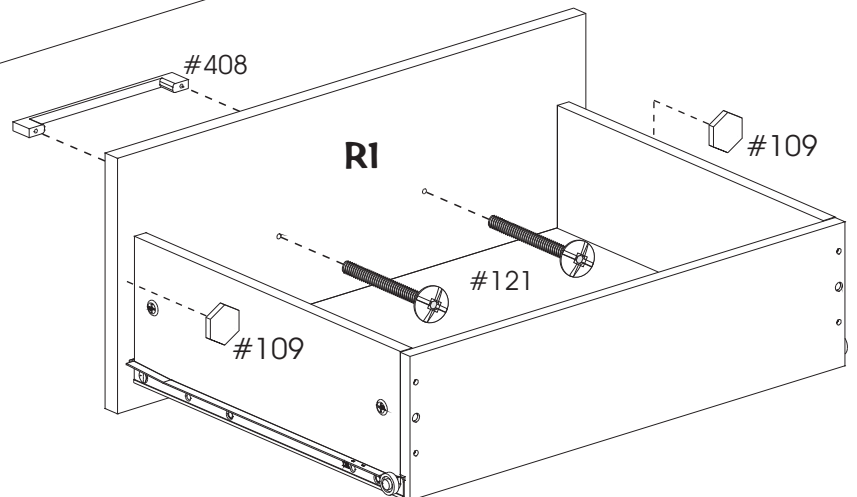
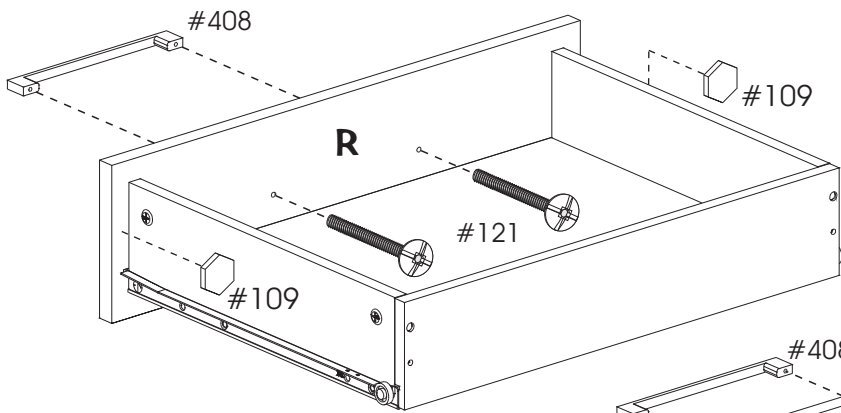

# 23

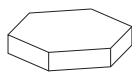
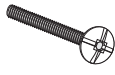

4X		#109
4X		#121
2X		#408

24

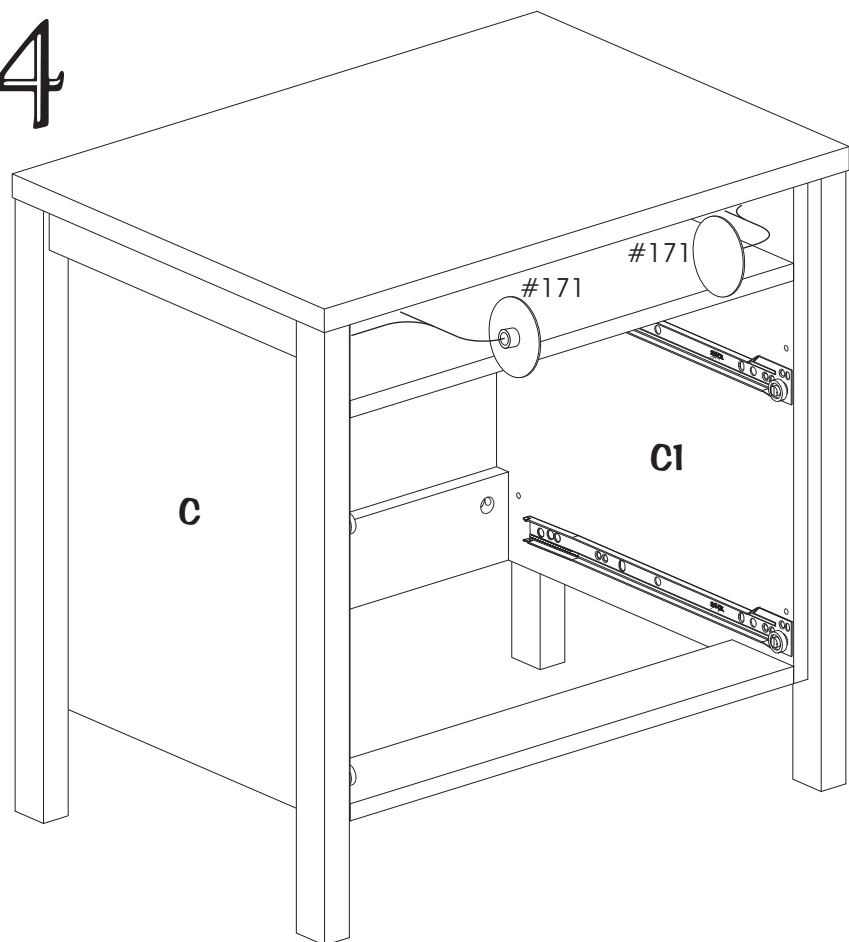

4X

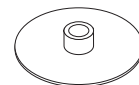

#171

25

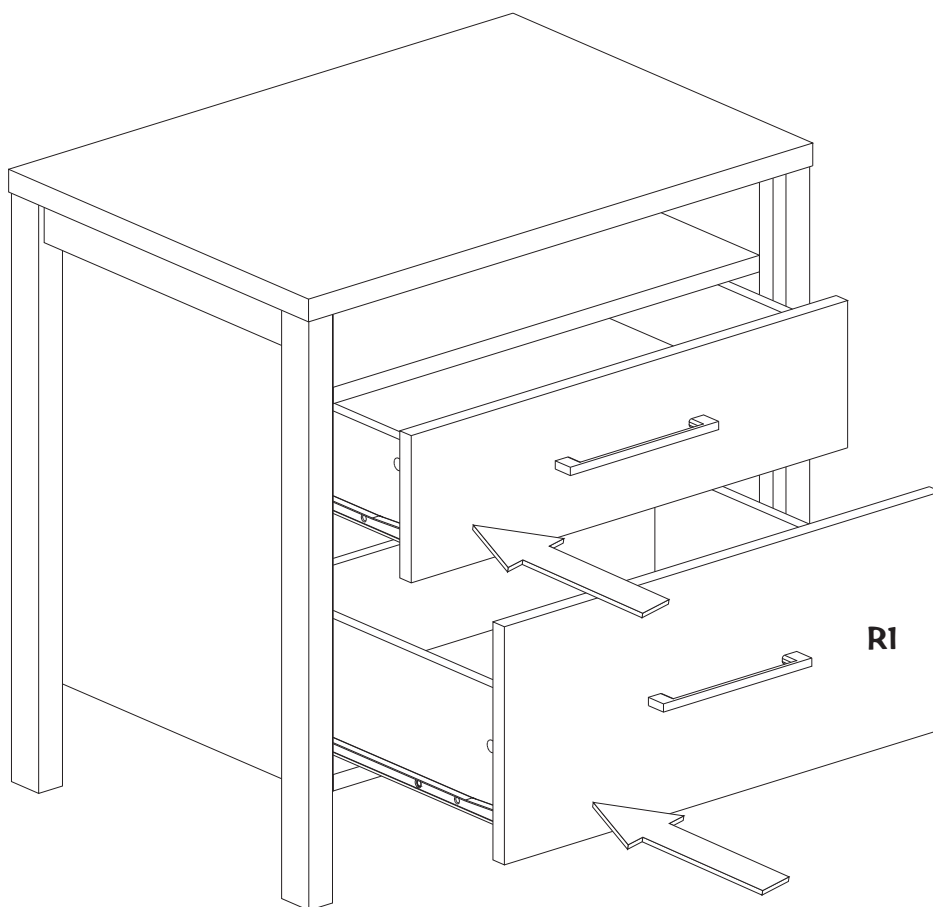

## MAINTENANCE TIPS / CONSEILS D'ENTRETIEN / CONSEJOS DE MANTENIMIENTO

- Never let liquids or damp cloths sit on this furniture.
- *Ne jamais laisser de liquide ou linge humide sur le meuble.*
- Nunca deje un líquido o un trapo húmedo sobre el mueble.



- Never use chemical cleaning products. They can damage the finish. For cleaning, use only a slightly damp cloth and wipe dry.
- *Ne jamais utiliser de nettoyeurs à base de produits chimiques, cela va endommager le fini. Utiliser seulement un linge légèrement humide.*
- Nunca utilice limpiadores a base de químicos, estos dañaran le acabado. Use sólo un paño húmedo.



- To avoid dulling of the finish, do not place furniture in direct sunlight.
- *Ne pas placer le meuble directement au soleil pour prévenir le ternissement.*
- No exponga el mueble directamente al sol para prevenir empañamiento.

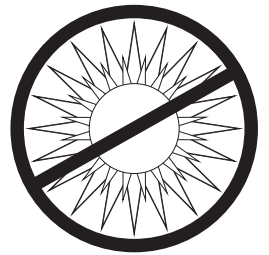

- Do not put plastic or rubber rings under appliances. Use cloth or felt protectors.
- *Évitez de déposer des appareils avec des rondelles de plastique ou de caoutchouc. Utilisez un protecteur en tissu ou en feutre.*
- Evite apoyar aparatos con redondeles de plástico o de goma. Utilizar un protector de tela o de fieltro.



- To clean, use a soft or slightly damp cloth, then wipe with a clean, dry cloth.
- *Pour nettoyer, utilisez un linge doux ou légèrement humecté. Essuyez par la suite avec un linge propre et sec.*
- Para limpiar, utilice un trapo suave o ligeramente humedecido. Seque luego con un trapo limpio y seco.



## 5 YEAR LIMITED WARRANTY

1. South Shore™ Furniture provides the original buyer with a warranty covering "defects" on furniture parts and workmanship for a period of 5 years from the date of purchase.
  2. The word "defect" as used in this warranty is defined as any imperfection that may impair the intended use of the product.
  3. This warranty is strictly limited to the repair or replacement of defective component parts, and excludes all other direct or indirect charges and expenses up to the limit permitted by law in your state/province.
  4. In the case of a discontinued part or product, South Shore™ Furniture promises to reimburse the value of that part or product.
  5. If a replacement part is unavailable, South Shore™ Furniture's liability to the buyer will not exceed the production cost of the part in question.
  6. This warranty only applies under conditions of normal domestic use. It does not cover defects resulting from commercial use, intentional damage, negligence, abuse, product modification, accidents, exposure to the elements, or maintenance that does not comply with the guidelines on our website.
  7. To honor this warranty, South Shore™ Furniture reserves the right to verify the grounds of any request and to ask for the original buyer's proof of purchase.
  8. This warranty is only valid on purchases made at authorized South Shore™ Furniture retailers in Canada, the U.S., Mexico, Puerto Rico and Bermuda.
  9. This warranty defines the limits of South Shore™ Furniture's liability, and entitles the original buyer to specific rights. Any warranty defined by law in your state/province is limited to a period of 5 years. If the law in your state/province prohibits this restriction, then it does not apply.
  10. South Shore™ Furniture will not reimburse defective furniture, but will replace it with an item of equivalent value.
- 
- To qualify for your warranty, please take a moment to fill out our on-line registration form ([southshorefurniture.com](http://southshorefurniture.com))

*Afin de bénéficier de votre garantie, nous vous invitons à remplir le formulaire d'enregistrement en ligne ([meublesrivesud.com](http://meublesrivesud.com))*

Para obtener su garantía, tenga a bien llenar nuestro formulario en línea ([southshorefurniture.com](http://southshorefurniture.com))

## GARANTIE LIMITÉE DE 5 ANS

1. Meubles South ShoreMC garantit à l'acheteur original, pour une période de 5 ans à partir de la date d'achat, toutes les composantes des meubles contre les « défauts » de matériaux et de main- d'œuvre.
2. Le mot « défaut » utilisé dans cette garantie signifie une imperfection pouvant altérer l'utilité pour laquelle le produit est destiné.
3. Cette garantie se limite strictement à la réparation ou au remplacement des pièces composantes défectueuses. Cette garantie exclut tous les autres frais et dépenses directs ou indirects et ce, jusqu'à la limite permise par la législation en vigueur dans votre lieu de résidence.
4. Dans le cas d'une réclamation concernant un produit ou une pièce discontinuée, Meubles South ShoreMC s'engage à rembourser la valeur du produit ou de la pièce en question.
5. À défaut de pouvoir fournir la pièce de remplacement, la responsabilité de Meubles South ShoreMC ne peut excéder la valeur équivalente au coût de production de la pièce en litige.
6. Cette garantie s'applique sous des conditions d'usage domestique normal et ne couvre pas les défauts pouvant résulter d'un usage commercial, de dommages intentionnels, de la négligence, de l'usage abusif, de modifications personnelles, d'un accident, de l'exposition aux éléments ou d'un entretien ne respectant pas les conseils décrits sur notre site Internet.
7. Comme condition pour fournir une pièce de remplacement, Meubles South ShoreMC se réserve le droit de vérifier le fondement de la requête, de même que d'exiger la preuve d'achat de l'acheteur original.
8. Cette garantie n'est valide que si et seulement si l'achat a été effectué chez un marchand autorisé par Meubles South ShoreMC au Canada, aux États-Unis, au Mexique, à Puerto Rico et aux Bermudes.
9. Cette garantie définit les limites de la responsabilité de Meubles South ShoreMC et donne à l'acheteur original des droits spécifiques. Toute garantie législative prévalant dans votre lieu de résidence est limitée à une période de 5 ans. Si cette restriction n'est pas permise par la législation de votre lieu de résidence, elle ne s'applique pas.
10. Meubles South ShoreMC ne remboursera pas un meuble défectueux, mais le remplacera par un autre de valeur équivalente.

1. South ShoreMR garantizan al comprador original, por un período de 5 años a partir de la fecha de compra, todas las piezas que componen el mueble contra los « defectos » de material y mano de obra.
2. La palabra « defecto » utilizada en esta garantía se define como toda imperfección que pueda alterar la utilidad para la cual se destina el producto.
3. Esta garantía se limita estrictamente a la reparación o reemplazo de las piezas que tengan componentes defectuosos. Esta garantía no incluye cualquier gasto directo o indirecto hasta el límite permitido por la legislación vigente en su lugar de residencia.
4. En el caso de una reclamación referente a un producto o pieza discontinuada, South ShoreMR se compromete a reembolsar el valor del producto o pieza en cuestión.
5. A falta de poder suministrar la pieza de repuesto, la responsabilidad de South ShoreMR no puede exceder el valor equivalente al costo de producción de la pieza en litigio.
6. Esta garantía se aplica bajo las condiciones de uso doméstico normal y no cubre los defectos que puedan resultar de un uso comercial, daños intencionales, negligencia, uso abusivo, modificaciones personales, un accidente, exposición a los elementos y mantenimiento sin respetar los consejos que se describen en este sitio web.
7. Como condición para suministrar una pieza de repuesto, South ShoreMR se reservan el derecho de verificar el fundamento de la solicitud, así como de exigir la prueba de compra del comprador original.
8. Esta garantía sólo será válida si la compra se efectuó en una tienda autorizado por Muebles South ShoreMR de Canadá, Estados Unidos, México, Puerto Rico o las Bermudas.
9. Esta garantía define los límites de la responsabilidad de South ShoreMR y otorga el comprador original los derechos específicos. Cualquier garantía legislativa que prevalece en su lugar de residencia está limitada a un período de 5 años. Si esta restricción no está permitida por la legislación de su lugar de residencia, ésta no se aplica.
10. South ShoreMR no hará ningún reembolso por muebles defectuosos, pero le enviará uno de valor equivalente.

## GARANTIA LIMITADA DE 5 AÑOS

### CUSTOMERS SERVICE / SERVICE À LA CLIENTÈLE / SERVICIO AL CLIENTE

## CANADA / USA

 **1-800-290-0465** 



6168, Rue Principale  
SAINTE-CROIX, QUÉBEC  
CANADA, G0S 2H0



FAX: 1-877-586-5339  
(CANADA / USA)

E-MAIL: [service@southshore.ca](mailto:service@southshore.ca)  
WEB: [www.southshore.ca](http://www.southshore.ca)



## INTERNATIONAL

 **418-926-2961** 



ASSEMBLY INSTRUCTIONS  
INSTRUCTIONS D'ASSEMBLAGE  
INSTRUCCIONES DE ENSAMBLAJE

Article/ Item/ Artículo

**-010-** Dresser  
Bureau  
Comoda



ADULT ASSEMBLY REQUIRED  
**DOIT ÊTRE ASSEMBLÉ PAR UN ADULTE**  
DEBE SER ENSAMBLADO POR UN ADULTA

ENGLISH

**N.B.:** It is important to carefully read the instructions before beginning the assembly.

Identify all the parts and hardware. We recommend that you assemble the unit on a carpeted floor to avoid scratches. To facilitate assembly 2 people are required. Keep the assembly instructions as **reference** and for warranty purposes. It contains all pertinent information regarding replacement parts and maintenance.

**N.B. Il est important de bien lire les instructions avant de commencer l'assemblage.**

Bien identifier les pièces et la quincaillerie. Il est recommandé d'assembler l'unité sur un tapis pour éviter les égratignures. Pour un assemblage facile et agréable ; 2 personnes sont requises. Gardez les instructions d'assemblage pour **référence** et pour la garantie. Elles contiennent toutes les informations pour un remplacement de pièce ou pour l'entretien périodique.

FRANÇAIS

**N.B. Lea con detenimiento las instrucciones antes de comenzar a ensamblar su mueble.**

Identifique las piezas y los artículos de ferretería. Se recomienda ensamblar la unidad sobre una alfombra para evitar los rasguños. Para un ensamblaje mas facil se necesitan dos personas. Mantenga el instructivo de ensamble como **referencia** para usos de garantía. Este instructivo contiene todas las informaciones necesarias para un sustitución de pieza o un mantenimiento periodico.

ESPAÑOL

**☎ 1-800-290-0465 ☎**

**#Instructions/ #Instructions/ #Instructivo**

**10025239**

## **WARNING**

**Serious or fatal crushing injuries can occur from furniture tip-over.**

**To help prevent tip-over:**

- Place heaviest items in the lowest drawers.
- Do not set TVs or other heavy objects on the top of this product. Never allow children to climb or hang on drawers, doors, or shelves.
- Never open more than one drawer at a time.

**Use of tip-over restraints only reduce, but not eliminate, the risk of tip-over.**

## **AVERTISSEMENT**

**Des blessures graves ou fatales peuvent résulter du basculement du meuble.**

**Afin d'éviter le basculement :**

- Placer les items les plus lourds dans les tiroirs du bas.
- Ne pas placer de TV ou d'autres objets lourds sur ce produit. Ne jamais laisser un enfant grimper sur les tiroirs, les portes et les tablettes ou s'accrocher à ceux-ci.
- Ne jamais ouvrir plus d'un tiroir à la fois.

**L'utilisation de dispositif anti-basculement ne peut que réduire les risques de basculement, sans les éliminer totalement.**

## **ADVERTENCIA**

**El vuelco del mueble puede ser causa de lesiones graves o de un aplastamiento fatal.**

**Para evitar el vuelco:**

- Ponga las cosas pesadas en los cajones más bajos.
- No ponga televisores u otros objetos pesados encima de este producto. Nunca permita que un niño se trepe o se cuelgue en cajones, puertas o estantes.
- Nunca abra más de un cajón a la vez.

**El uso de sujetadores para evitar el vuelco sólo puede disminuir el riesgo de un vuelco, pero no lo elimina.**

-EXPLODED VIEW (Piece numbers for reference)FACING THE UNIT

-VUE EXPLOSÉE (Numéros des pièces pour références)FACE AU MEUBLE

-VISIÓN DE CONJUNTO (Número de las piezas para referencia)FRENTE AL MUEBLE

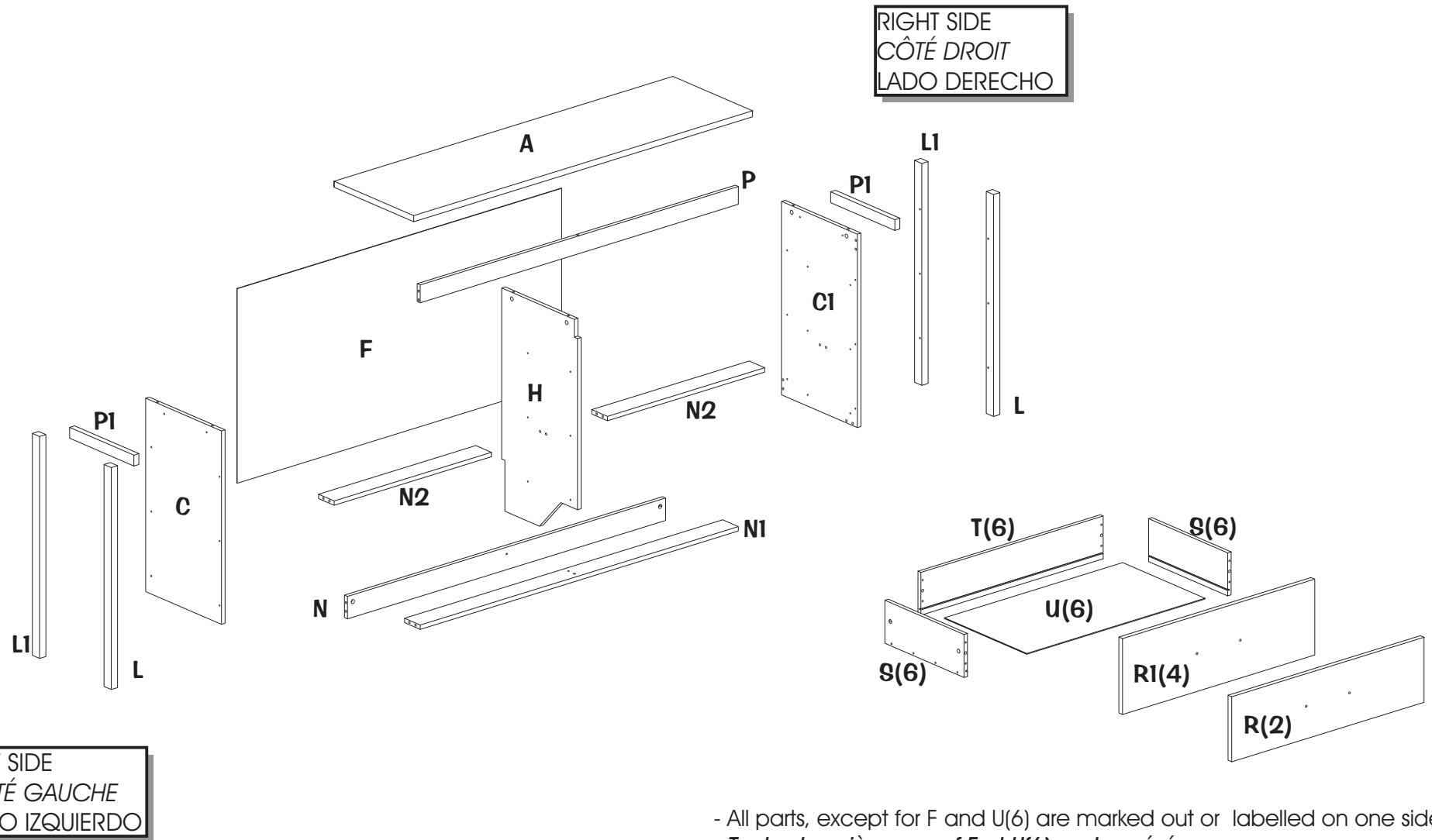

- All parts, except for F and U(6) are marked out or labelled on one side.
- *Toutes les pièces, sauf F et U(6) sont repérées par marquage sur un des côtés, ou par étiquetage sur une des faces.*
- Todas las piezas, a excepción de F y U(6) están identificadas con una marca en los lados o con etiquetas en una de las caras.

**HOW TO USE THE DOWEL(-144-) AND THE ECCENTRIC NUT(-158-)**  
**EXEMPLE D'UTILISATION (GOUJON(-144-) ET ECROU(-158-))**  
**EJEMPLO DE UTILIZACIÓN (CLAVIJA(-144-) Y TUERCA EXCÉNTRICA(-158-))**

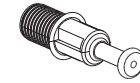

-144-



-158-

ENGLISH

- A. Fully insert the "quick fit dowel -144-" into the specified holes.
- B. To withdraw the "quick fit dowel -144-", do not use any tool, unscrew it with the hand.
- C. With your thumb, insert the "eccentric-nut -158-" into the specified holes with the arrow pointing towards the insertion hole.
- D. Insert the pieces into one another and make sure they are completely united.
- E. To lock the pieces together, turn (tighten) the "eccentric-nut -158-" to the right for slightly more than half a turn.

FRANÇAIS





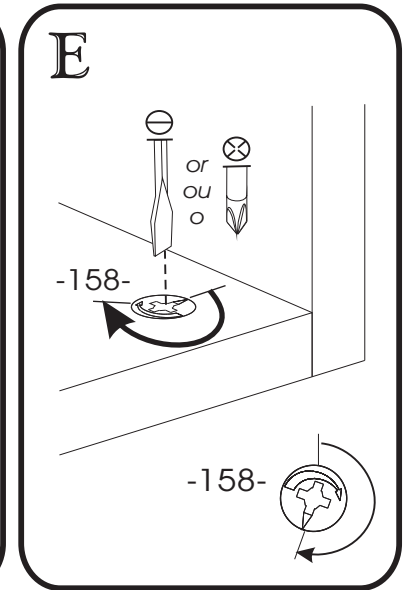
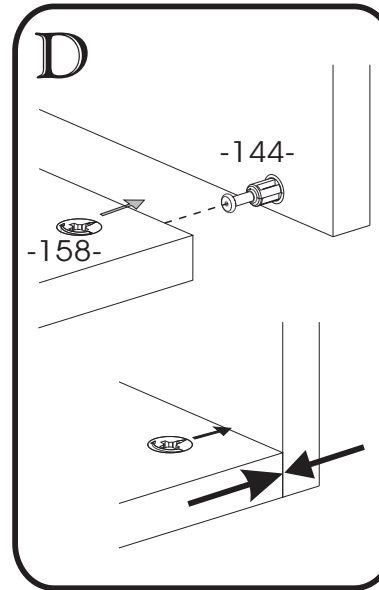
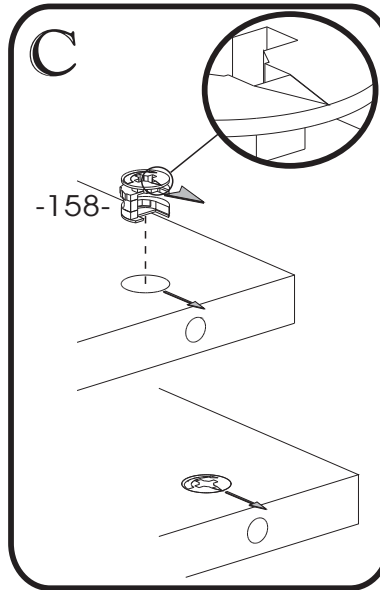
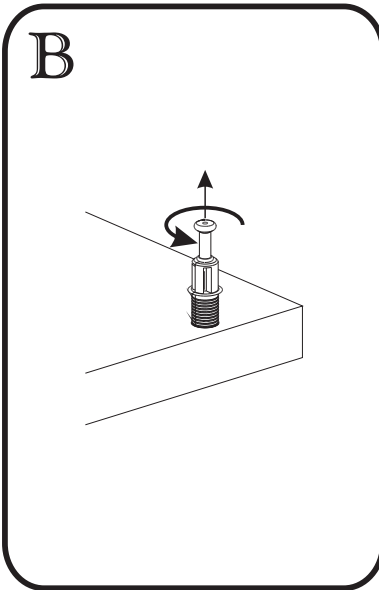
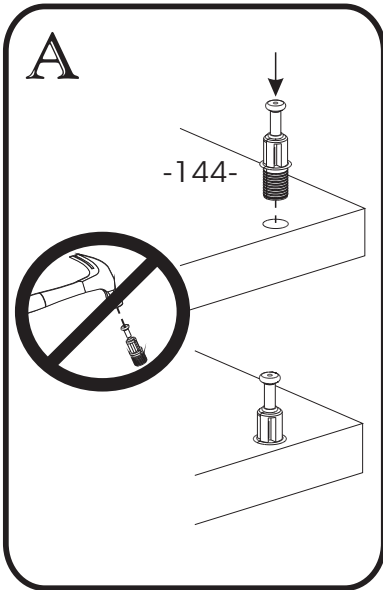

- A. Insérer jusqu'au fond le «goujon à enfoncer -144-» dans les trous mentionnés.
- B. Pour retirer le «goujon à enfoncer -144-», n'utiliser aucun outil, dévisser le à la main.
- C. Avec le pouce, insérer «l'écrou excentrique -158-» dans les trous mentionnés, la flèche vers le trou d'insertion.
- D. Joindre les pièces l'une dans l'autre et s'assurer qu'elles sont bien unies l'une contre l'autre.
- E. Tourner (serrer) «l'écrou excentrique -158-» vers la droite, un peu plus d'un demi tour, pour bloquer les pièces ensemble.

ESPAÑOL

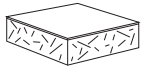
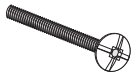
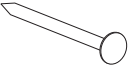
- A. Introduzca el "clavija -144-" hasta el fondo en todos los agujeros mencionados.
- B. Para retirar el "clavija -144-", no utilizar herramientas, desatornillar el a la mano.
- C. Introduzca con el pulgar la "tuerca excéntrica -158-" en los agujeros mencionados, con la flecha apuntando hacia el agujero de inserción.
- D. Una las piezas entre sí. Asegúrese de que se encuentren bien unidas.
- E. Haga girar hacia la derecha y ajuste la "tuerca excéntrica -158-" dando algo más que una media vuelta para que las piezas queden atrancadas.

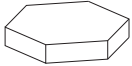
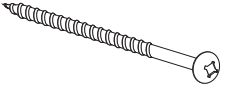

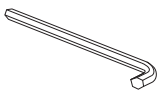
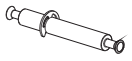
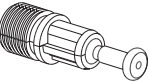
\*\*\*THINGS TO REMEMBER FOR ASSEMBLING/À RETENIR LORS DE L'ASSEMBLAGE/ A RECORDAR DURANTE EL ENSAMBLAJE\*\*\*  
 FOR YOUR INFORMATION ONLY                      POUR INFORMATION SEULEMENT                      A TÍTULO INFORMATIVO

CODE CODE CODIGO	QTY QTE CANTIDAD	HARDWARE DESCRIPTION DESCRIPTION DE LA QUINCAILLERIE DESCRIPCION DE LA FERRETERÍA	
<u>006</u>	6	FELT <b>FEUTRE</b> FIELTRO	
<u>087</u>	12	1" HANDLE SCREW <b>VIS 1" POUR POIGNÉE</b> TORNILLO 1" PARA MANIJA	
<u>090</u>	22	3/4" COMMON NAIL <b>CLOU À TÊTE 3/4"</b> CLAVO DE 3/4" CON CABEZA	
<u>092</u>	48	10 MM EURO SCREW <b>VIS EURO 10 MM</b> TORNILLO EURO 10 MM	
<u>099</u>	5	9/16" ROUND HEAD SCREW <b>VIS 9/16" TÊTE RONDE</b> TORNILLO 9/16" CABEZA REDONDA	
<u>109</u>	12	BUMPER <b>COUSSINET</b> COJINETE	
<u>116</u>	1	2 1/2" ROUND HEAD SCREW <b>VIS 2 1/2" TÊTE RONDE</b> TORNILLO 2 1/2" CABEZA REDONDA	
<u>121</u>	12	7/8" HANDLE SCREW <b>VIS 7/8" POUR POIGNÉE</b> TORNILLO 7/8" PARA MANIJA	
<u>131</u>	1	HEXAGONAL KEY <b>CLÉ HEXAGONALE</b> LLAVE HEXAGONAL	
<u>143</u>	1	DOUBLES PIN QUICK FIT <b>GOUJON DOUBLE QUICK FIT 60M</b> CLAVIJA DOBLE QUICK FIT	
<u>144</u>	14	QUICK FIT DOWEL <b>GOUJON À ENFONCER</b> TARUGO DE FIJACION	
<u>158</u>	16	15 X 12 MM CAM KLIX <b>ÉCROU KLIX 15 X 12 MM</b> TUERCA KLIX 15 X 12 MM	

CODE CODE CODIGO	QTY QTE CANTIDAD	HARDWARE DESCRIPTION DESCRIPTION DE LA QUINCAILLERIE DESCRIPCION DE LA FERRETERÍA	
<u>199</u>	1	SECURITY BRACKET <b>ÉQUERRE DE SÉCURITÉ</b> ESCUARDA DE SEGURIDAD	
<u>207</u>	pairs 6 paires pars	METAL DRAWER SLIDE (R/L) 350 MM <b>COULISSE DE MÉTAL (D/G) 350 MM</b> CORREDERA DE MÉTAL (I/D) 350 MM	
<u>208</u>	pairs 6 paires pars	METAL DRAWER SLIDE (R/L) 350 MM <b>COULISSE DE MÉTAL (D/G) 350 MM</b> CORREDERA DE MÉTAL (I/D) 350 MM	
<u>231</u>	15	PLASTIC DOWEL 8MM <b>GOUJON DE PLASTIQUE 8MM</b> TARUGO DE PLASTICO 8MM	
<u>299</u>	2	6 x 36 FLAT HEAD SCREW <b>VIS 6 x 36 TÊTE PLATE</b> TORNILLO 6 x 36 CABEZA PLANA	
<u>393</u>	12	8/32 x 10 INSERTION <b>INSERTION 8/32 x 10</b> INSERCIÓN 8/32 x 10	
<u>408</u>	6	HANDLE <b>POIGNÉE</b> MANIJA	
<u>414</u>	4	29mm FLAT HEAD SCREW <b>Vis 29mm TÊTE PLATE</b> TORNILLO 29mm CABEZA PLANA	
<u>516</u>	6	HARDWARE FOR AMBIDEXTROUS DRAWER <b>QUINCAILLERIE POUR TIROIR AMBIDEXTRE</b> FERRETERIA PARA AMBIDEXTRO CAJONE	

\* In the hardware package, you have spare parts -231-.

\* Dans la quincaillerie, vous avez les pièces de remplacement -231-.

\* En la ferreteria, tenemos las piezas de reemplazo -231-.

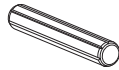

\* TOOLS REQUIRED/OUTILS REQUIS/HERRAMIENTAS REQUERIDOS:

- 2 PEOPLES/2 PERSONNES/2 PERSONAS

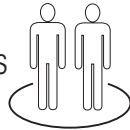

- HAMMER/MARTEAU/MARTILLO

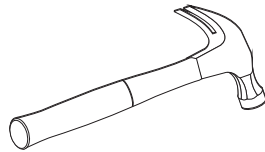

- STANDARD/PLAT/PLANO

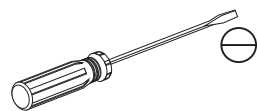

- PHILLIPS/ÉTOILE/ESTRELLA

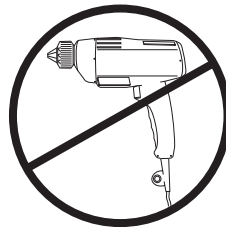
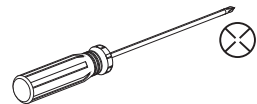

OR/OU/O

- ROBERTSON/CARRÉ/CUADRADO

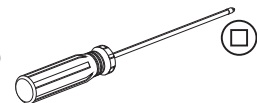

# 1

Required/Requis/Requerido

X12



-393-

X1

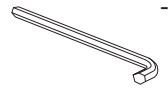

-131-

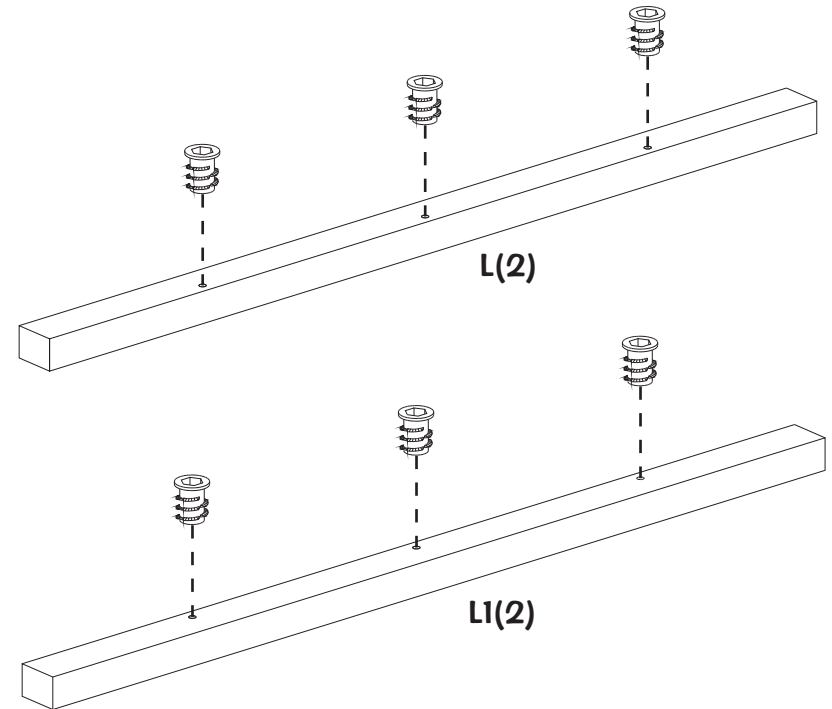



- Screw -393-(12) into L(2) and L1(2) with -131- .

- Visser -393-(12) dans L(2) et L1(2) avec -131- .

- Atornillar -393-(12) en L(2) y L1(2) con -131- .

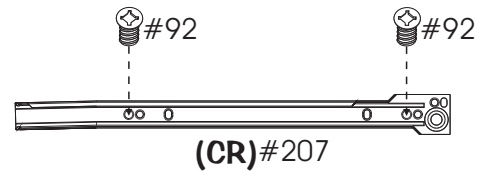
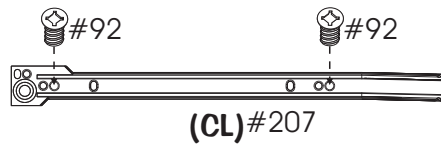
# 2

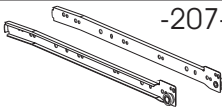

Required/Requis/Requerido	
X24	-92- 
Pairs 6 Paires Pares	-207- 

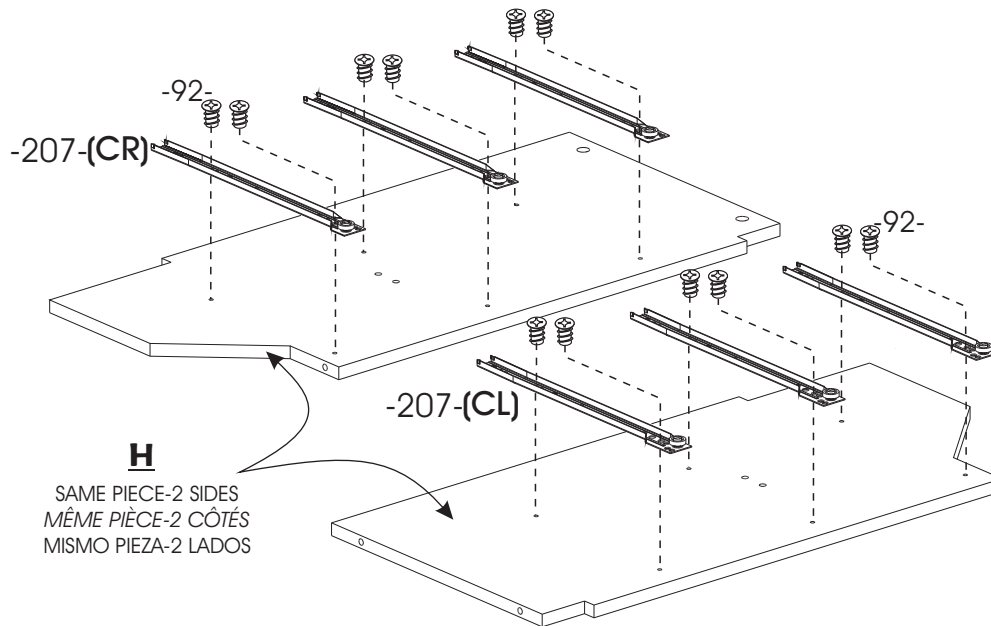
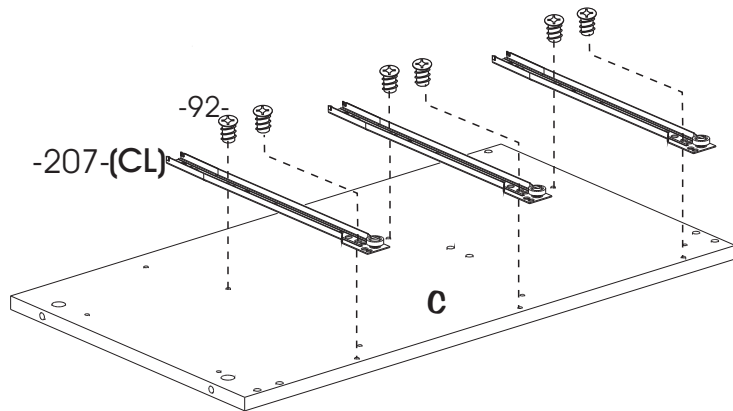

**H**  
 SAME PIECE-2 SIDES  
 MÊME PIÈCE-2 CÔTÉS  
 MISMO PIEZA-2 LADOS

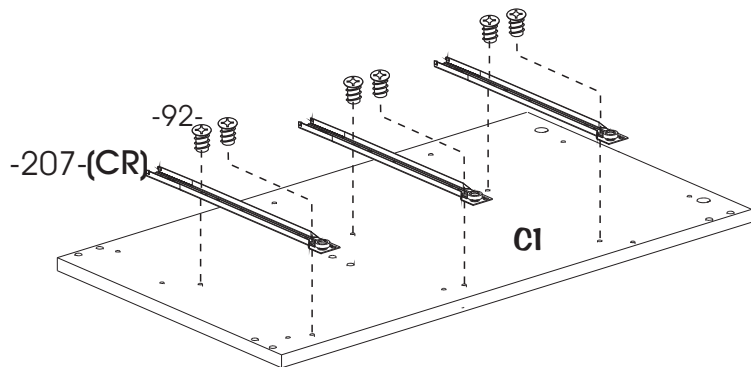

- With -92- screw -207-(CR) into C1 and H.
- With -92- screw -207-(CL) into C and H.

- Avec -92- visser -207-(CR) dans C1 et H.
- Avec -92- visser -207-(CL) dans C et H.

- Con -92-, atornillar -207-(CR) sobre C1 y H.
- Con -92-, atornillar -207-(CL) sobre C y H.

# 3



Required/Requis/Requerido

X16



-158-

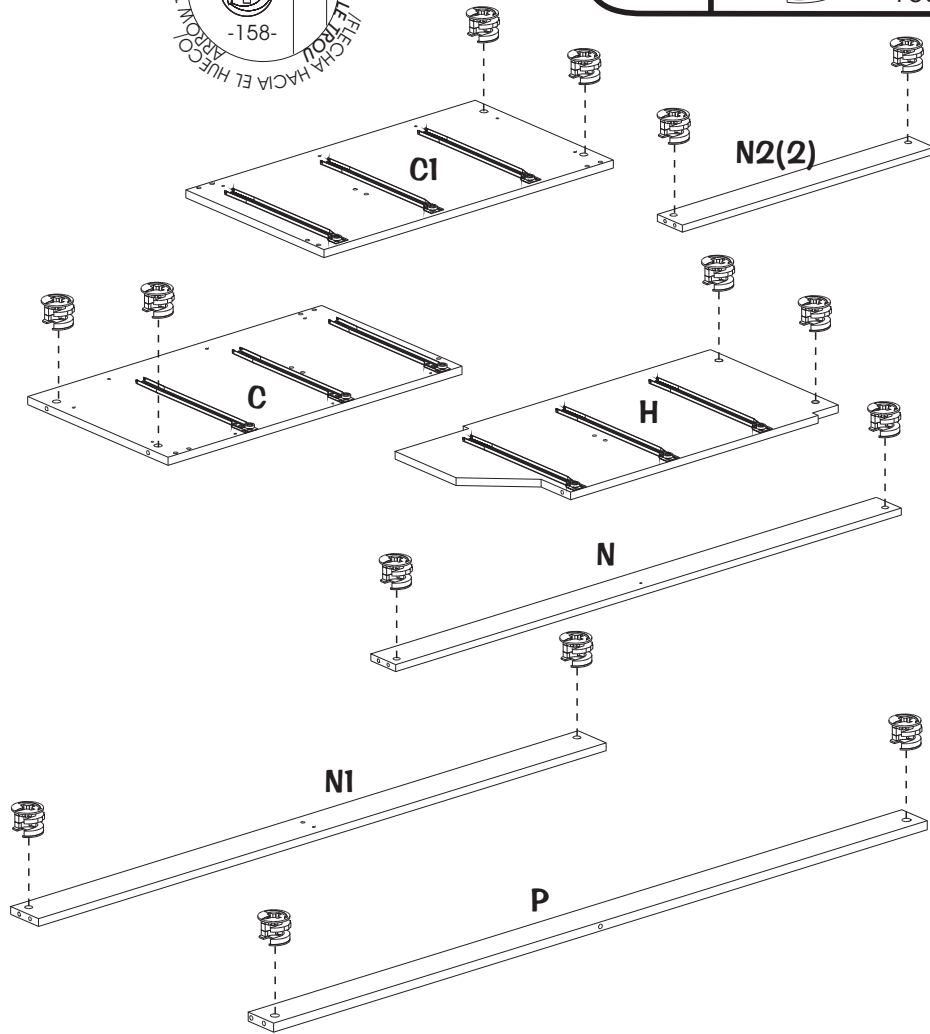

- With thumb, insert -158-(16) into C, C1, H, N(2), N1, N2 and P.  
(Make sure the little arrow is towards the insertion hole.)
- Avec le pouce, insérer -158-(16) dans C, C1, H, N(2), N1, N2 et P.  
(Assurez-vous que la flèche pointe vers le trou d'insertion.)
- Con el pulgar, insertar -158-(16) en C, C1, H, N(2), N1, N2 y P.  
(Asegurarse que la flecha esté orientada hacia el hueco de inserción.)

# 4

Required/Requis/Requerido

X14

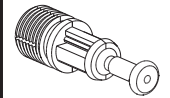

-144-

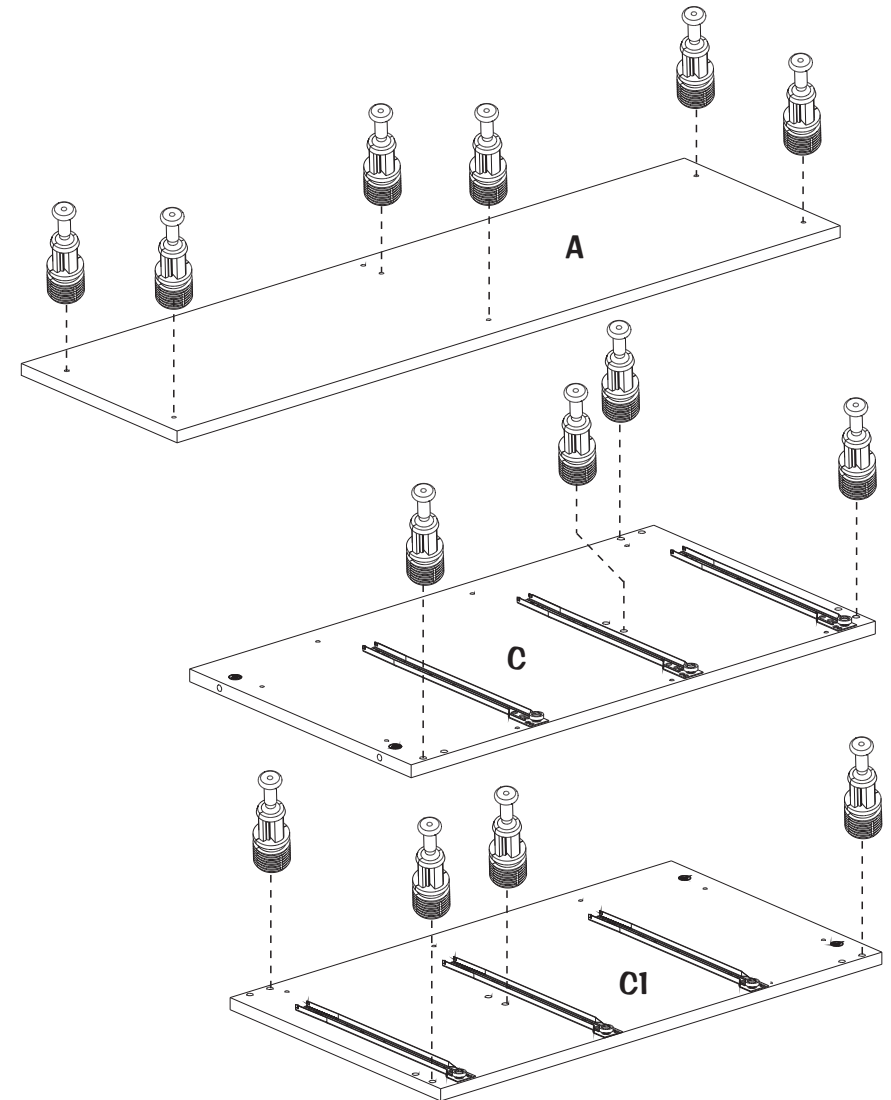

- Insert -144-(14) into A, C and C1.
- Insérer -144-(14) dans A, C et C1.
- Insertar -144-(14) en A, C y C1.

5

Required/Requis/Requerido

X12

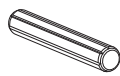

-231-

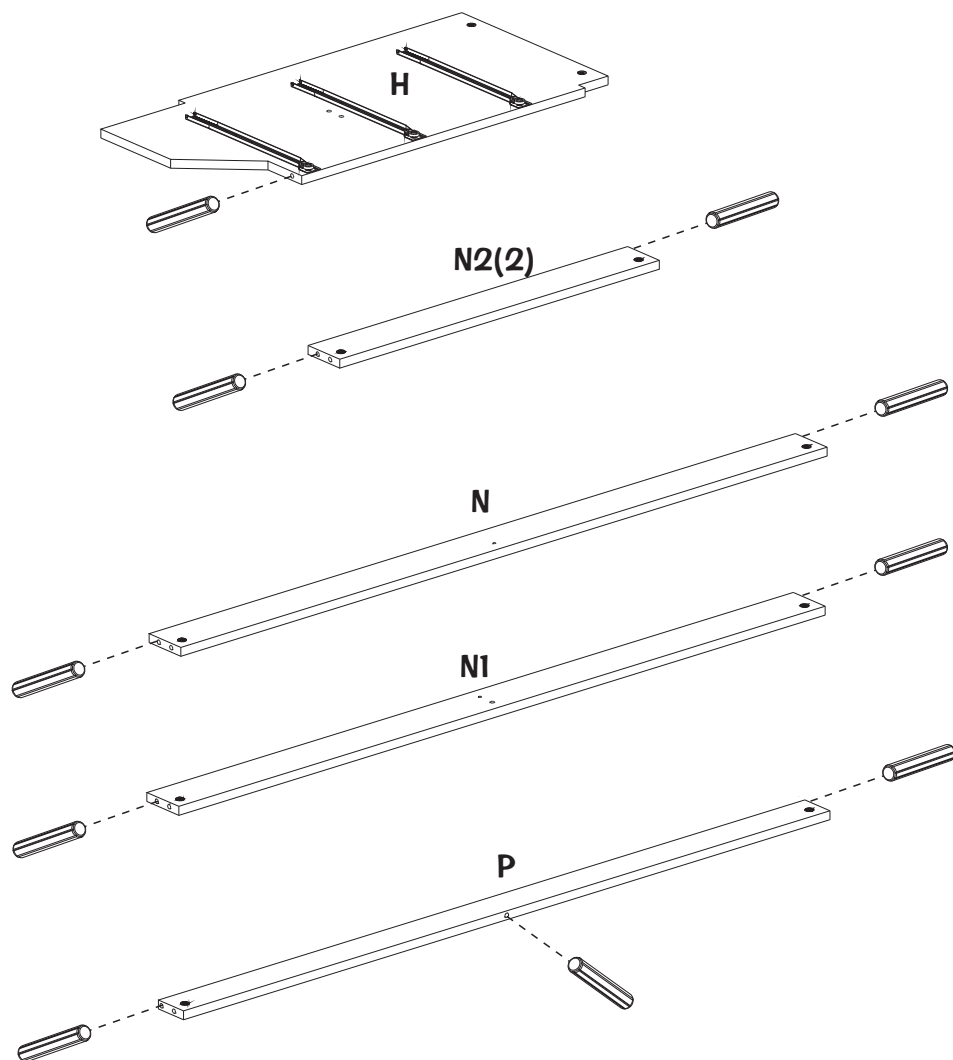

- Insert -23(12)1 into H, N(2), N1, N2 and P.
- Insérer -231(12) dans H, N(2), N1, N2 et P.
- Insertar -231(12) en H, N(2), N1, N2 y P.

6

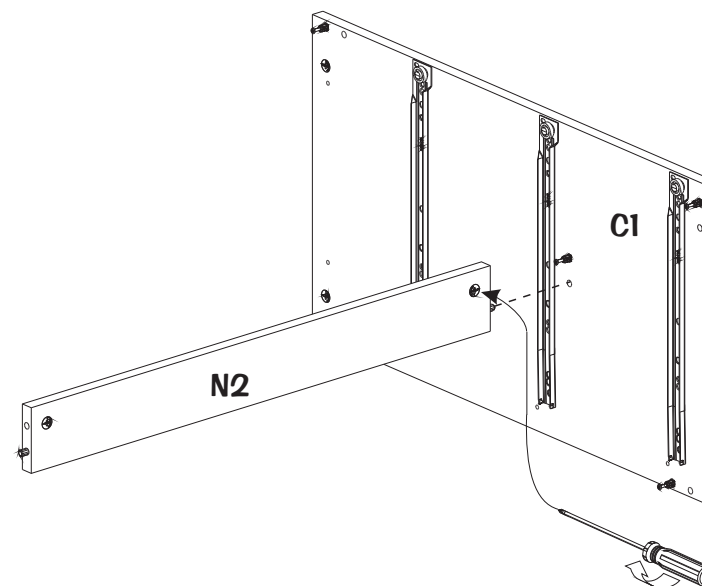
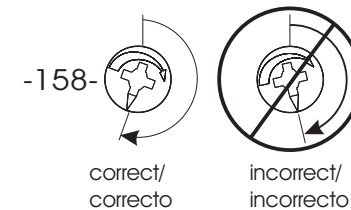

- Insert N into C1.
- Tighten right -158-(1) little more than a half turn on N to lock pieces together.
- Insérer N dans C1.
- Tourner -158-(1) un peu plus qu'un demi tour à droite sur N pour barrer les pièces ensemble.
- Insertar N en C1.
- Girar -158-(1) un poco más que una media vuelta hacia la derecha sobre N para trancar las piezas juntas.

7

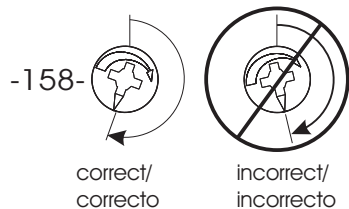

Required/Requis/Requerido

X1

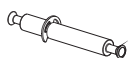

-143-

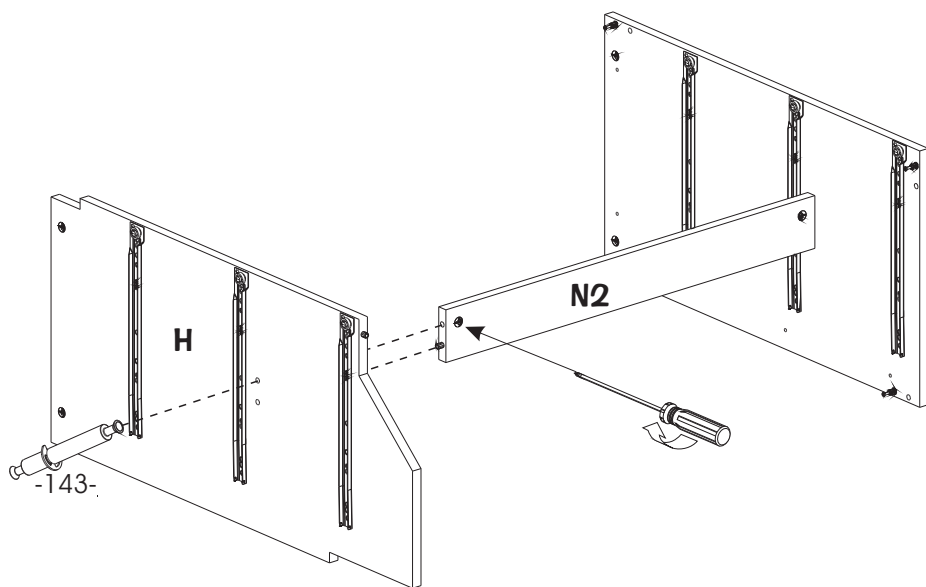

- Insert H into N.
- Insert -143- through H into N.
- Tighten right -158-(1) little more than a half turn on N to lock pieces together.
- Insérer H dans N .
- Insérer -143- à travers H dans N .
- Tourner -158-(1) un peu plus qu'un demi tour à droite sur N et pour barrer les pièces ensemble.
- Insertar H en N.
- Insertar -143- a través H en N.
- Girar -158-(1) un poco más que una media vuelta hacia la derecha sobre N para trancar las piezas juntas.

8

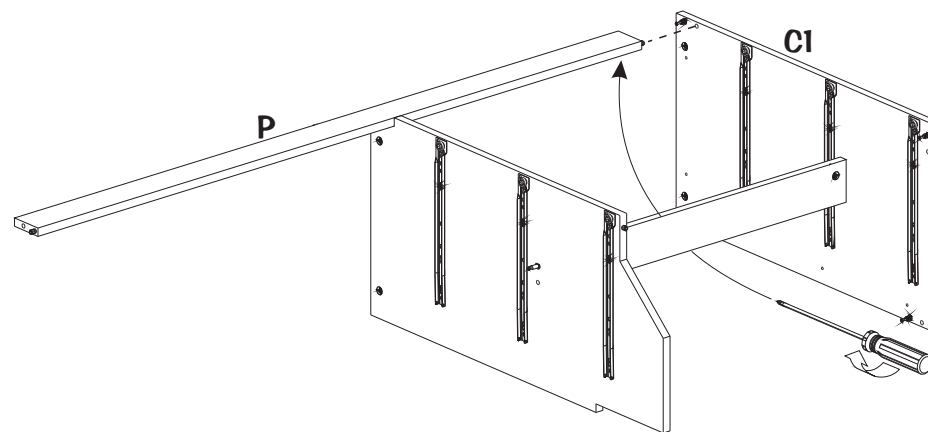
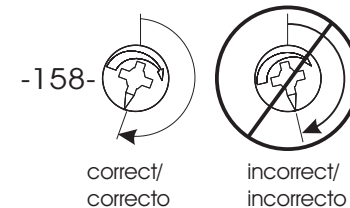

- Insert P into C1.
- Tighten right -158-(1) little more than a half turn on P to lock pieces together.
- Insérer P dans C1 .
- Tourner -158-(1) un peu plus qu'un demi tour à droite sur P pour barrer les pièces ensemble.
- Insertar P en C1.
- Girar -158-(1) un poco más que una media vuelta hacia la derecha sobre P para trancar las piezas juntas.

# 9

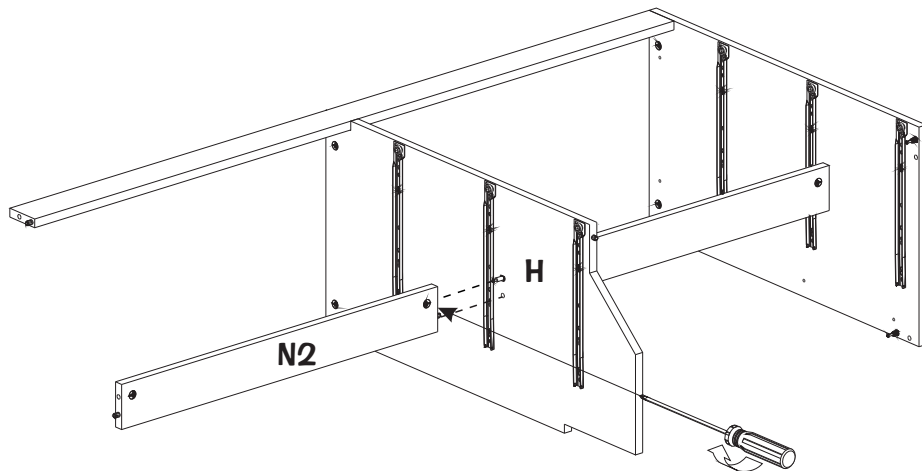
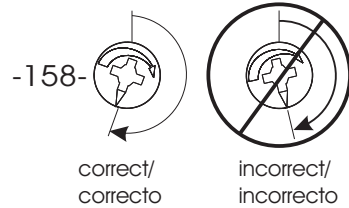

- Insert N into H.
- Tighten right -158-(1) little more than a half turn on N to lock pieces together.

- Insérer N dans H .  
 - Tourner -158-(1) un peu plus qu'un demi tour à droite sur N pour barrer les pièces ensemble.

- Insertar N en H.  
 - Girar -158-(1) un poco más que una media vuelta hacia la derecha sobre N para trancar las piezas juntas.

# 10

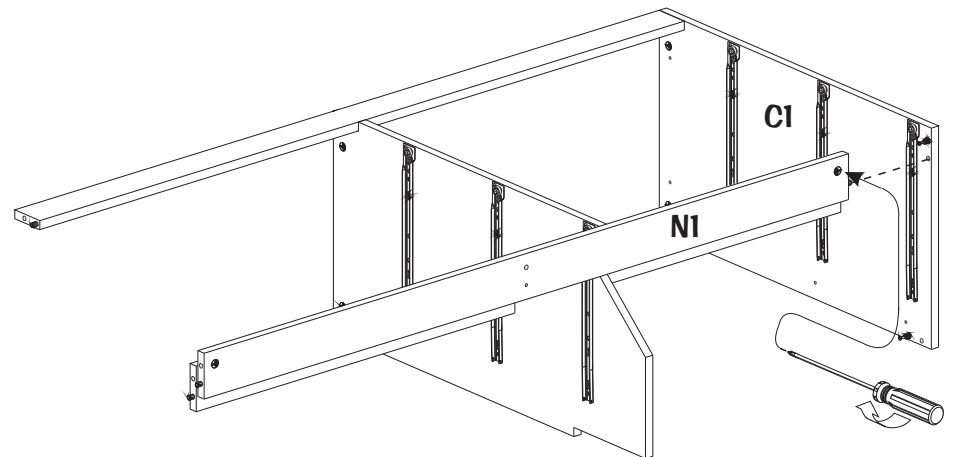
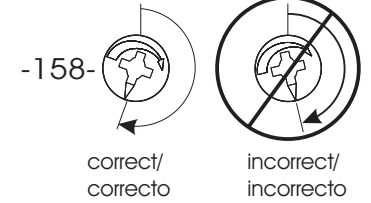

- Insert N2 into C1.
- Tighten right -158-(1) little more than a half turn on N2 to lock pieces together.

- Insérer N2 dans C1 .  
 - Tourner -158-(1) un peu plus qu'un demi tour à droite sur N2 pour barrer les pièces ensemble.

- Insertar N2 en C1.  
 - Girar -158-(1) un poco más que una media vuelta hacia la derecha sobre N2 para trancar las piezas juntas.

# 11

Required/Requis/Requerido

X1

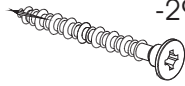

-299-

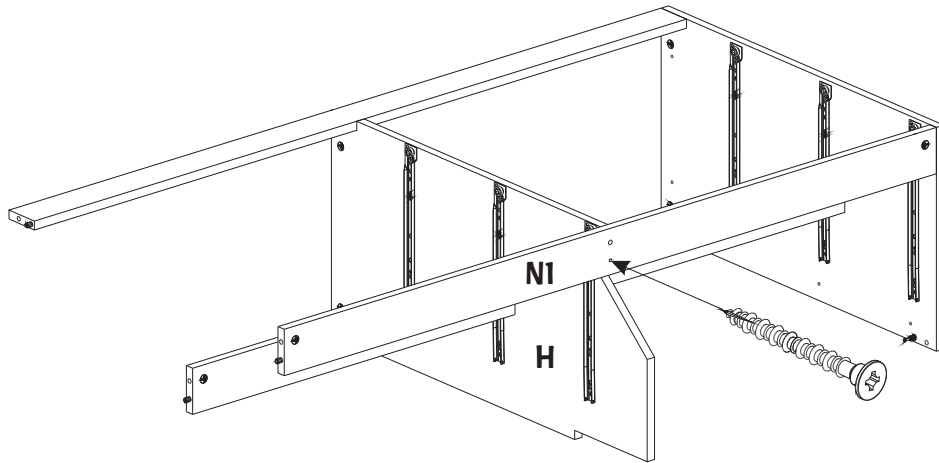

- Screw -299- through N2 into H .
- Visser -299- à travers N2 dans H.
- Atornillar -299- a través N2 en h.

# 12

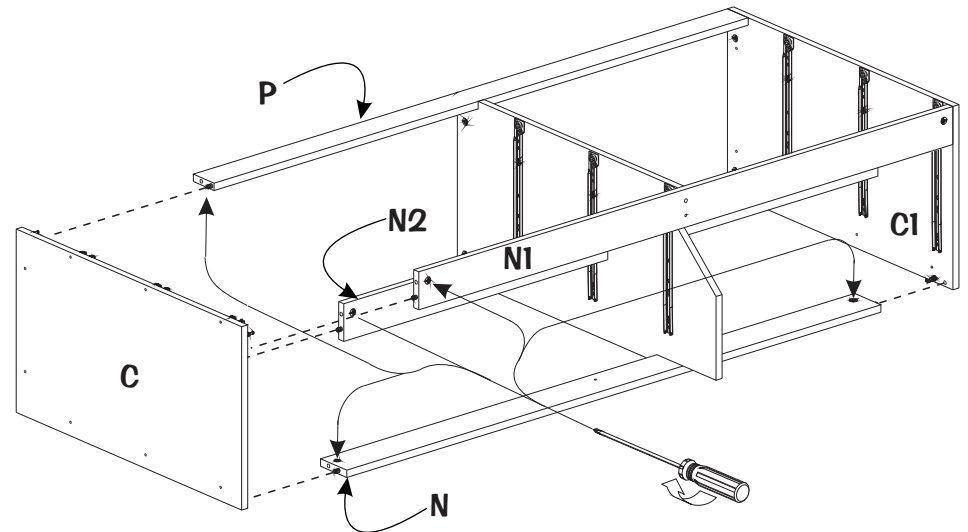
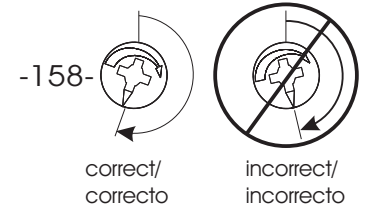

- Insert N1 and C into C1, N, N2 and P .
- Tighten right -158-(5) little more than a half turn on N, N1, N2 and P to lock pieces together.
- Insérer N1 et C dans C1, N, N2 et P .
- Tourner -158-(5) un peu plus qu'un demi tour à droite sur N, N1, N2 et P pour barrer les pièces ensemble.
- Insertar N1 y C en C1, N, N2 y P.
- Girar -158-(5) un poco más que una media vuelta hacia la derecha sobre N, N1, N2 y P para trancar las piezas juntas.

# 13

Required/Requis/Requerido

X6

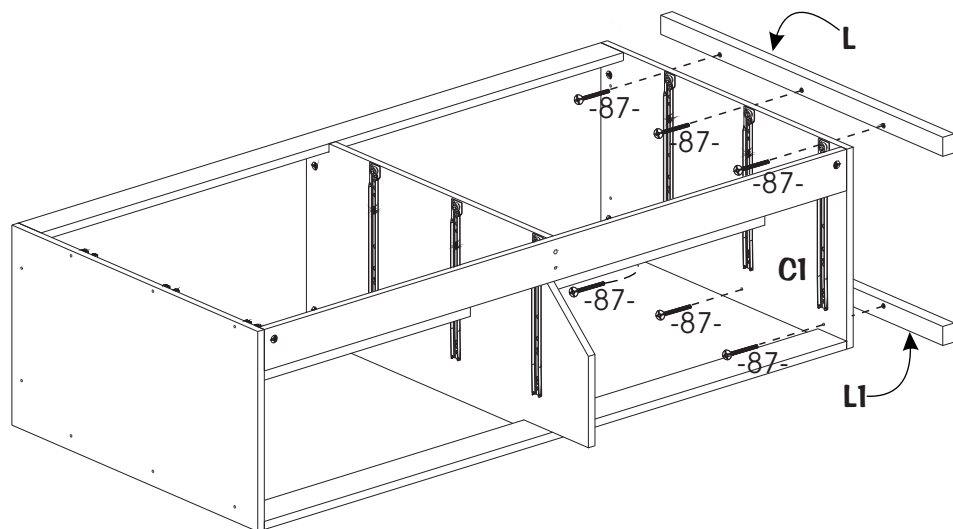
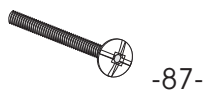

- Screw -087- through C1 into L and L1 .
- Visser -087- à travers C1 dans L et L1.
- Atornillar -087- a través C1 en L y L1.

# 14

Required/Requis/Requerido

X2

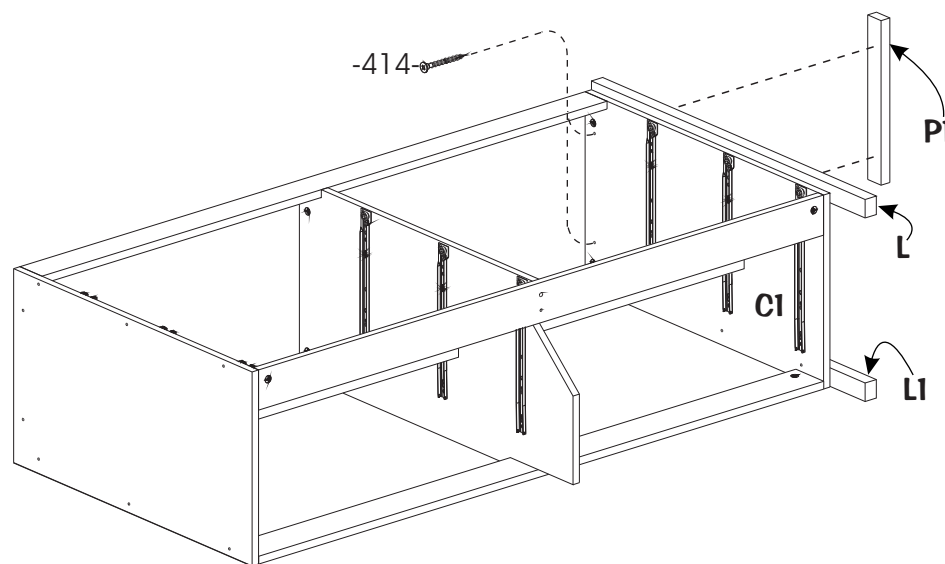
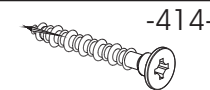

- Screw -414- through C1 into P1 .
- Visser -414- à travers C1 dans P1.
- Atornillar -414- a través C1 en P1.

# 15

Required/Requis/Requerido

X6

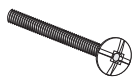

-87-

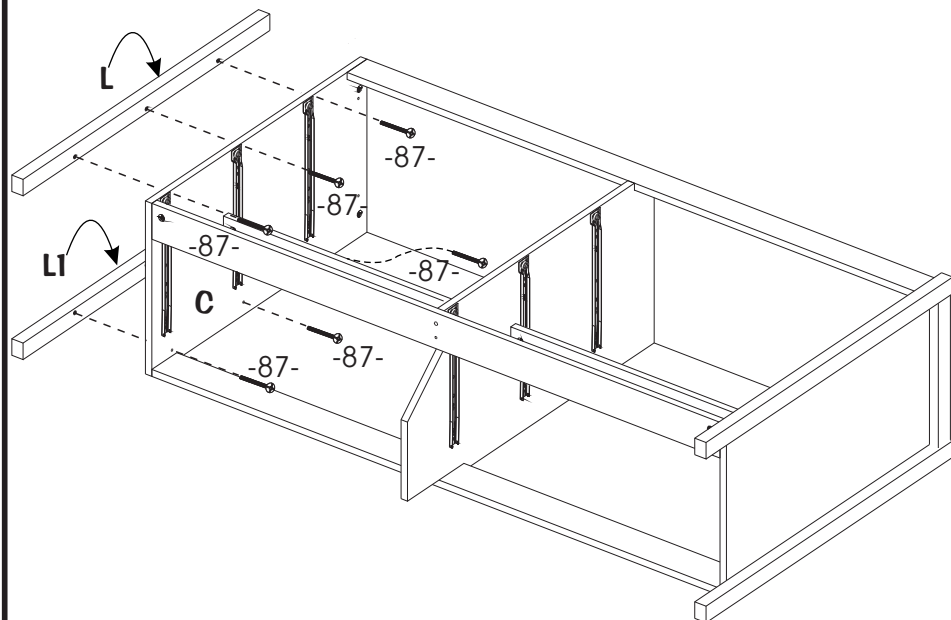

- Screw -087- through C into L and L1 .
- Visser -087- à travers C dans L et L1.
- Atornillar -087- a través C en L y L1.

# 16

Required/Requis/Requerido

X2

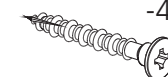

-414-

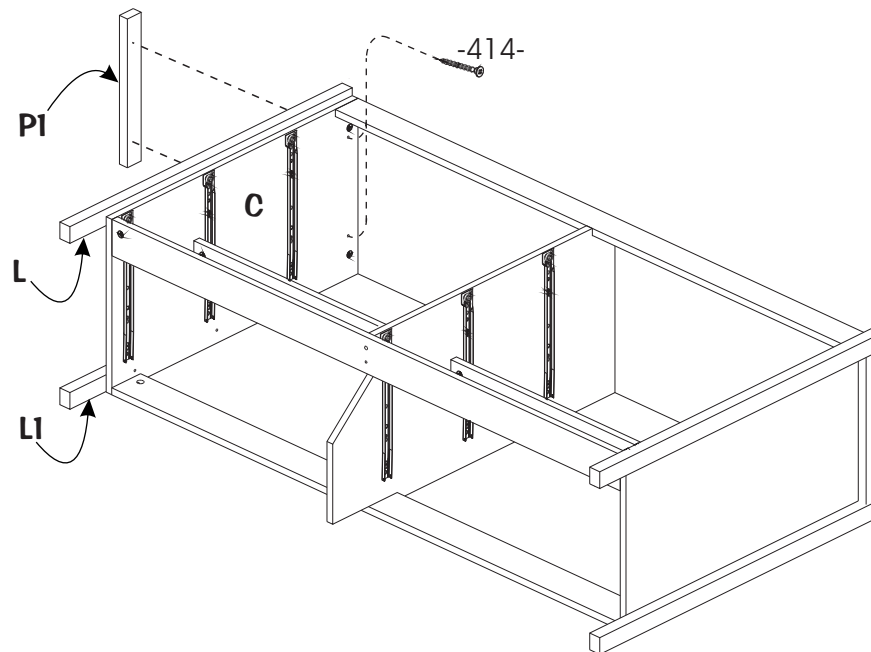

- Screw -414- through C into P1 .
- Visser -414- à travers C dans P1.
- Atornillar -414- a través C en P1.

# 17

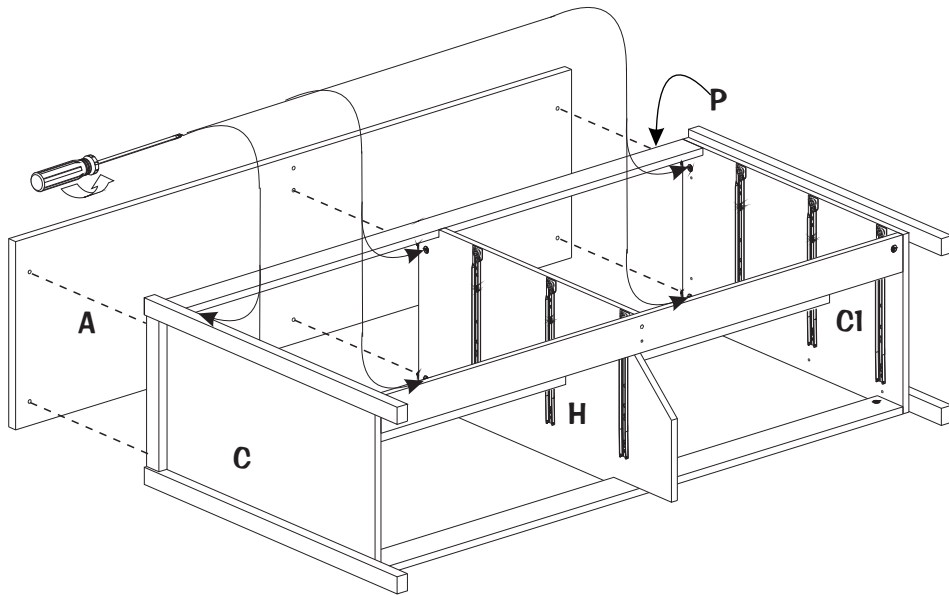
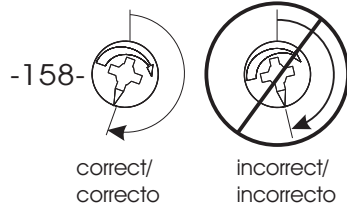

- Insert A into C, C1 and H.
- Tighten right -158-(6) little more than a half turn on C, C1 and H to lock pieces together.

- Insérer A dans C, C1 et H.
- Tourner -158-(6) un peu plus qu'un demi tour à droite sur C, C1 et H pour barrer les pièces ensemble.

- Insertar A en C, C1 y H.
- Girar -158-(6) un poco más que una media vuelta hacia la derecha sobre C, C1 y H para trancar las piezas juntas.

# 18

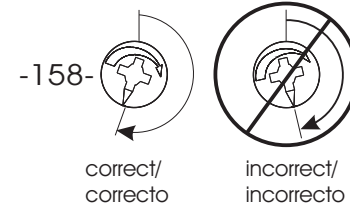

Required/Requis/Requerido

X1

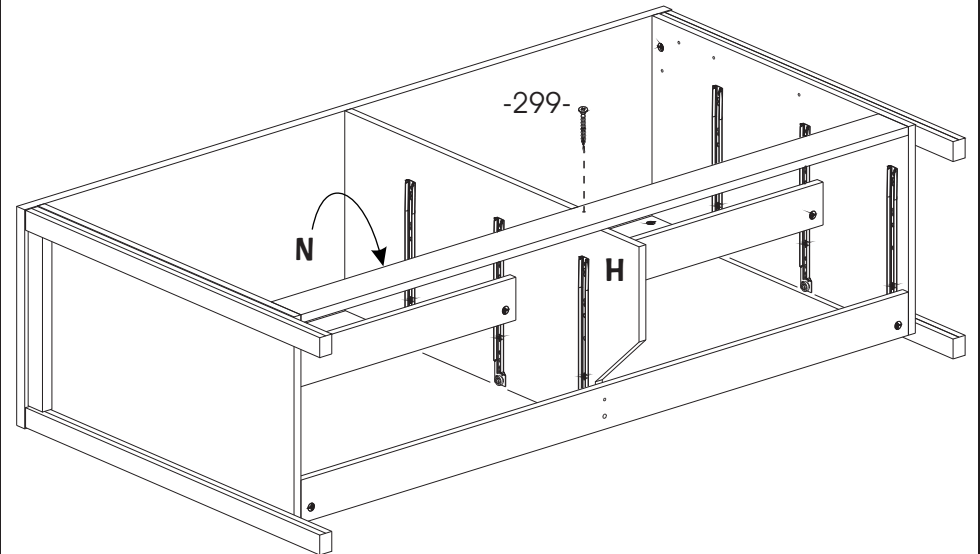
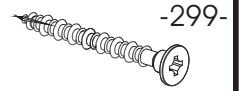

- Screw -299- through N1 into H.
- Visser -299- à travers N1 dans H.
- Atornillar -299- a través N1 en H.

# 19

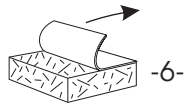

Pull the paper off.  
Enlever le papier.  
Quitar el papel.

Required/Requis/Requerido

X6		-6-
X22		-90-
X4		-99-

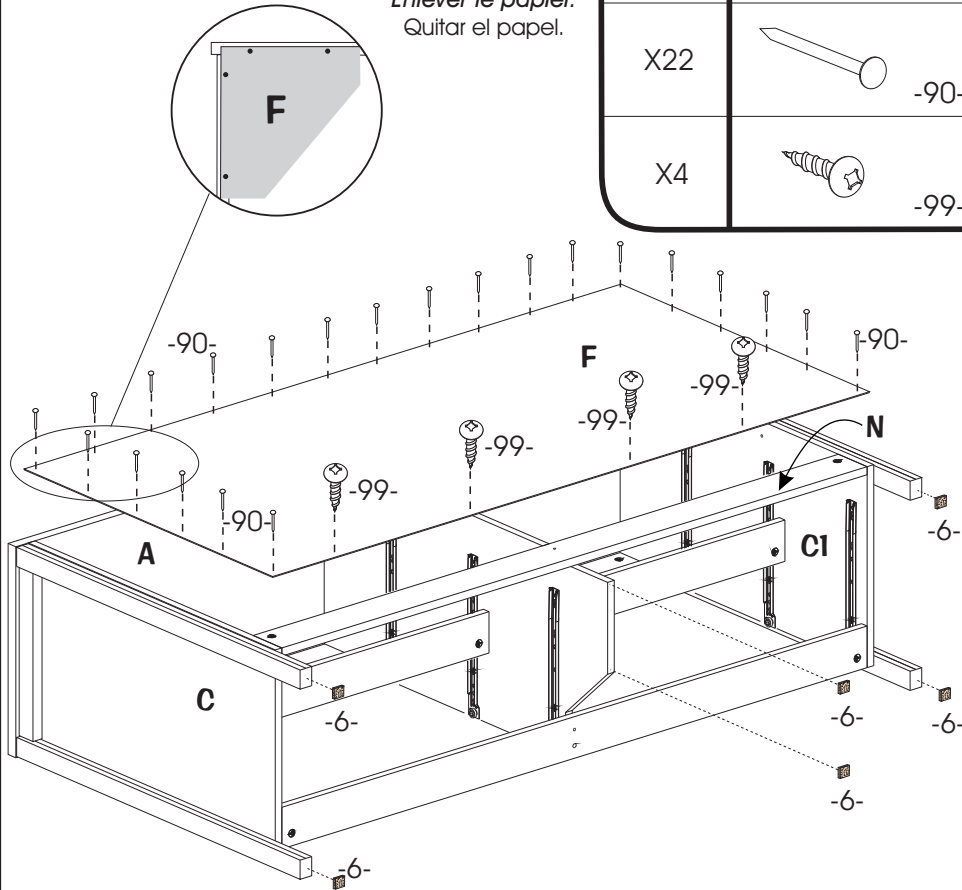

- Make sure the unit is level (squared).
- In beginning by the corners, nail F to A, C and C1 with -90-(22).
- Screw -99-(4) through F into N1.
- Stick -6-(6) under L and L1.
- Assurez vous que l'unité soit au niveau (à l'équerre).
- En commençant par les coins, Clouer F à A, C et C1 avec -90-(22).
- Visser -99-(4) à travers F dans N1.
- Coller -6-(6) sous L et L1.
- Cerciorarse de que la unidad se encuentre a nivel.
- Comenzando por las esquinas, clavar F a A, C y C1 con -90-(12).
- Atornillar -99-(4) a través F en N1
- Pegar -6-(6) debajo L y L1.

## HARDWARE / QUINCAILLERIE / FERRETERÍA

**-516-**

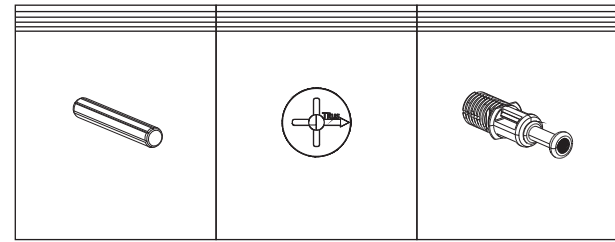

Each contain  
Chacun contient  
Cada uno contiene

4X



#533

4X

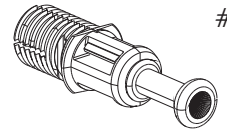

#535

8X

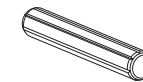

#229

# 20



Required/Requis/Requerido

X8		-229-
X4		-533-

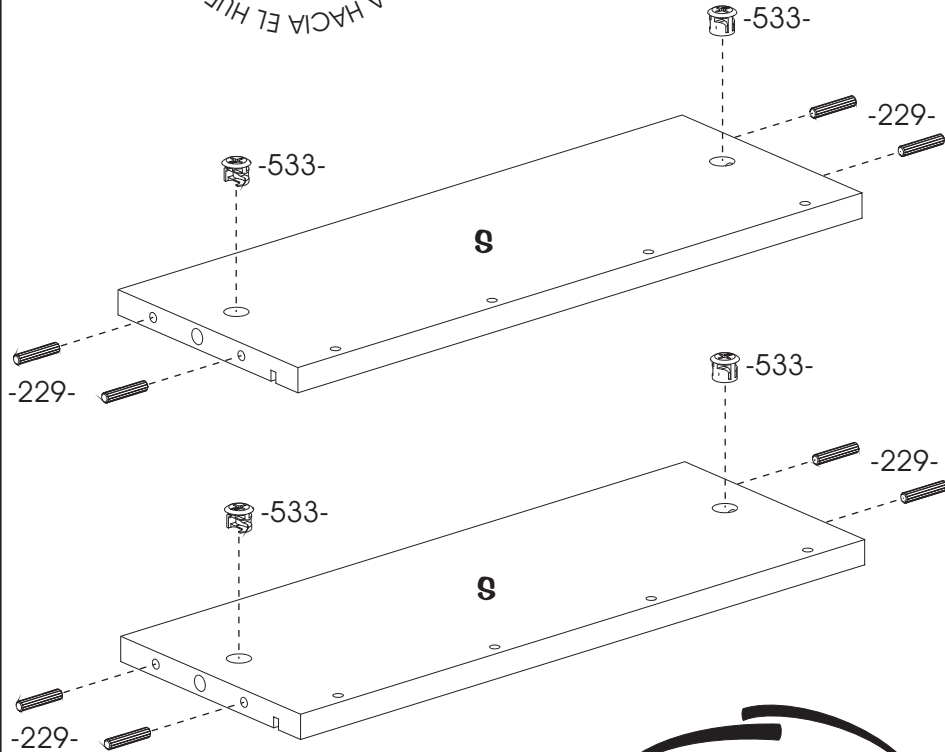

**6x** Drawers  
Tiroirs  
Cajones

- Insert -229- and -533- into S.
- Insérer -229- et -533- dans S.
- Insertar -229- y -533- en S.

# 21

Required/Requis/Requerido

X4		-535-
----	--	-------

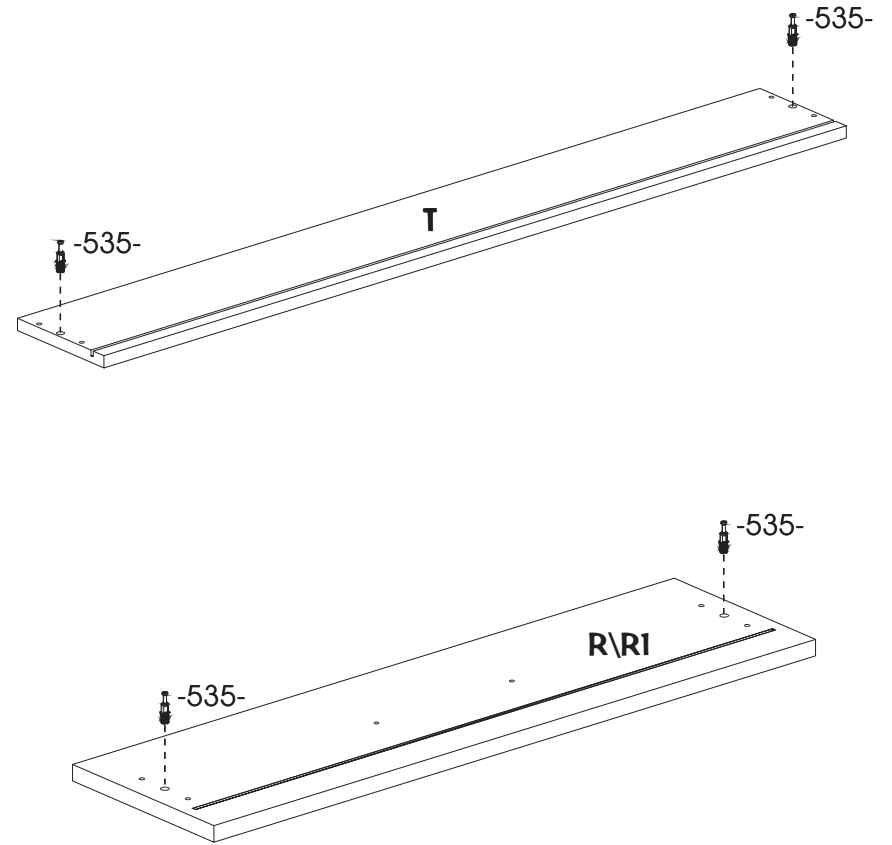

**6x** Drawers  
Tiroirs  
Cajones

- Insert -535- into R, R1 and T.
- Insérer -535- dans R, R1 et T.
- Insertar -535- en R, R1 y T.

# 22

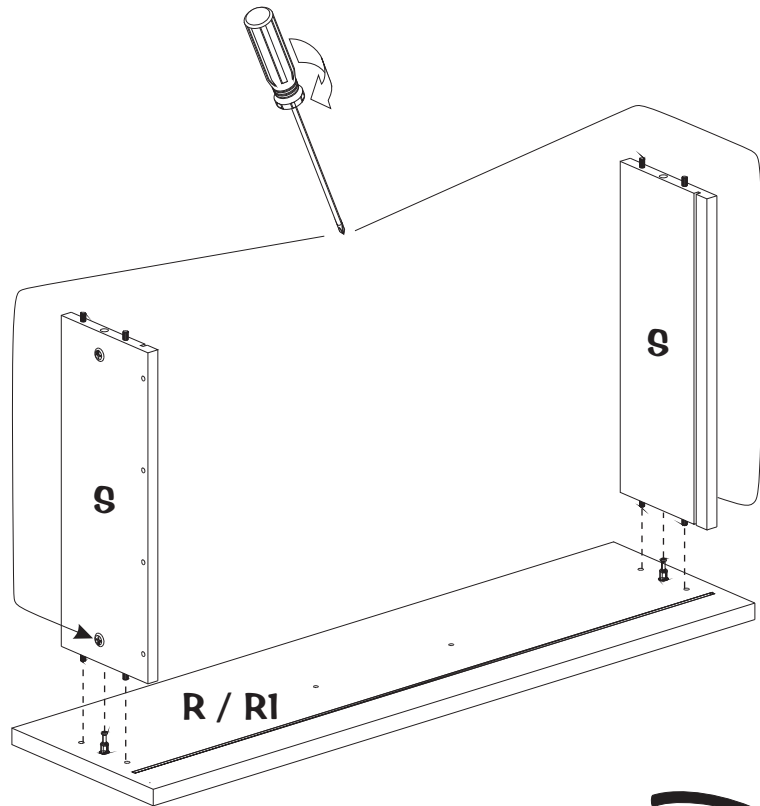
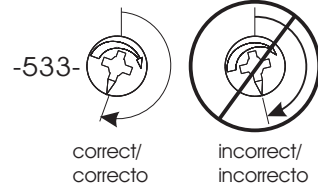

**6x** Drawers  
Tiroirs  
Cajones

- Insert S(2) into R, R1.
- Insérer S(2) dans R, R1.
- Insertar S(2) en R, R1.

# 23

**6x** Drawers  
Tiroirs  
Cajones

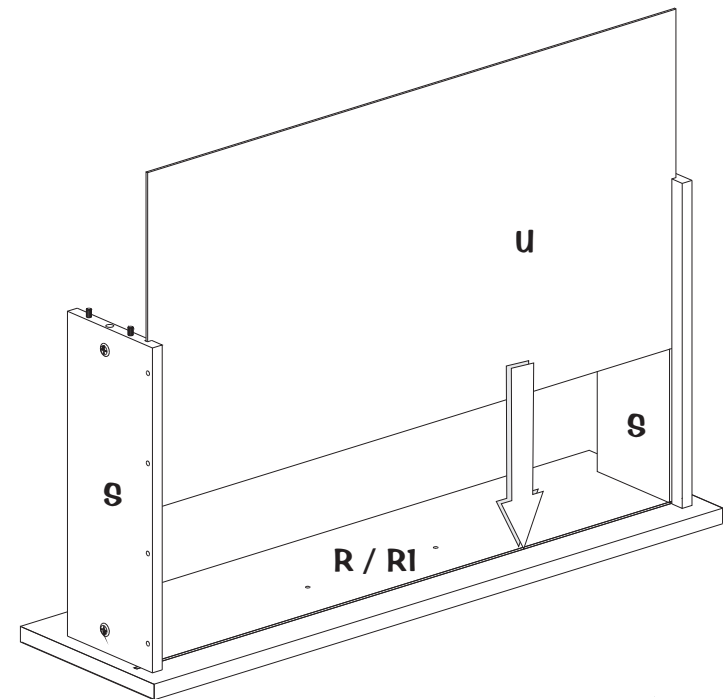

- Slide U (not printed) into the grooves of S(2), R, R1.
- Glisser U (non inscrit) dans les rainures de S(2), R, R1.
- Deslizar U (no escrito) en las ranuras de S(2), R, R1.

# 24

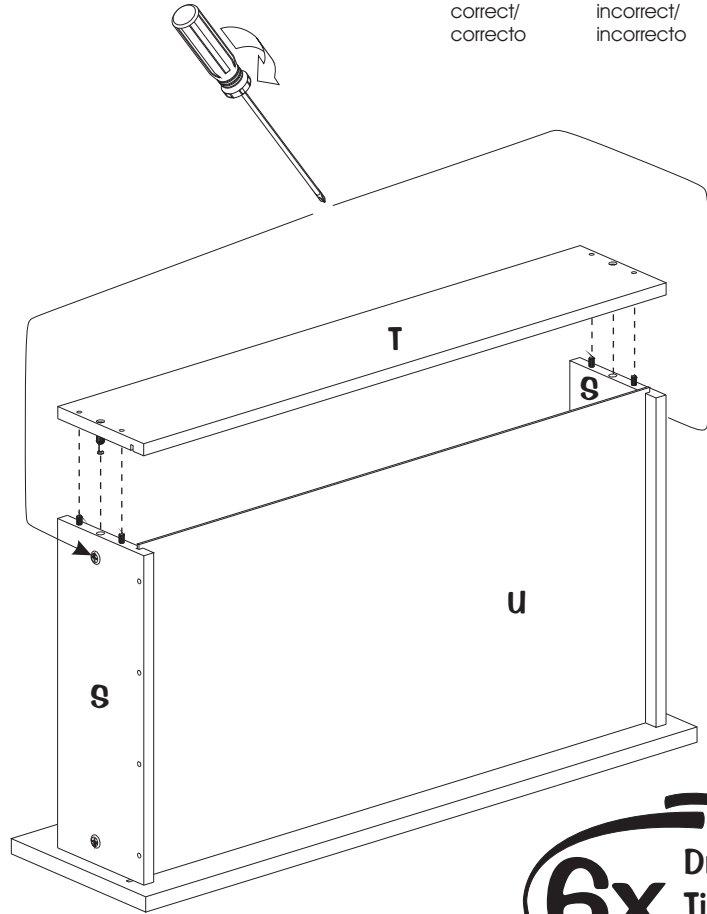
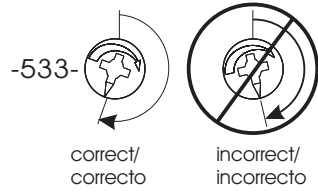

**6x** Drawers  
Tiroirs  
Cajones

- Insert T into S(2).
- Insérer T dans S(2).
- Insertar T en S(2).

# 25

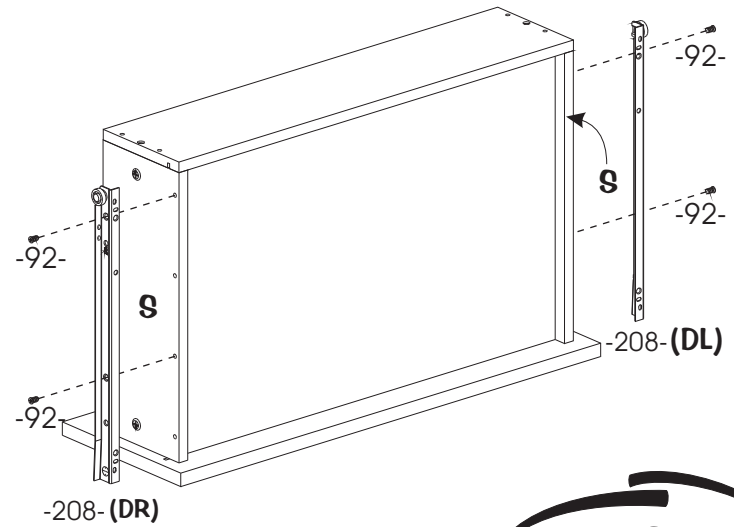
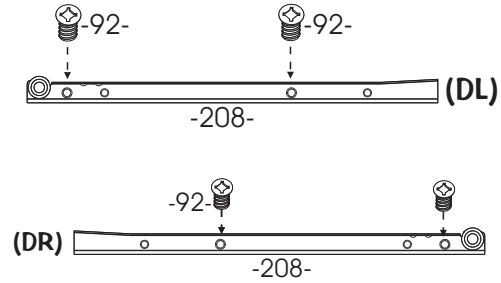

**6x** Drawers  
Tiroirs  
Cajones

- With -92-, screw -208-(DL) on S.
- With -92-, screw -208-(DR) on S.
- Avec -92-, visser -208-(DL) sur S.
- Avec -92-, visser -208-(DR) sur S.
- Con -92-, atornillar -208-(DL) sobre S.
- Con -92-, atornillar -208-(DR) sobre S.

Required/Requis/Requerido

X4



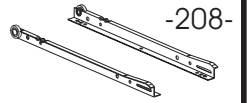

Pairs  
1 Paires  
Pares



# 26

**6x** Drawers  
Tiroirs  
Cajones

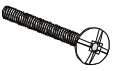
Required/Requis/Requerido

X2		-109-
X2		-121-
X1		-408-

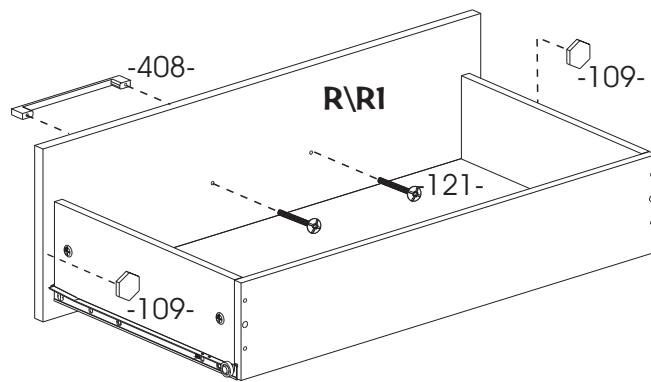

- Screw -408-(6) to R(2) and R1(4) with -121-(12). (6 drawers)
- Stick -109-(2) on R1(2) and R(4).

- Visser -408-(6) à R(2) et R1(4) avec -121-(12). (6 tiroirs)
- Coller -109-(2) sur R1(2) et R(4).

- Atornillar -408-(6) en R(2) y R1(4) con -121-(12). (6 cajones)
- Pegar -109-(2) sobre R1(2) y R(4).

# 27

- Safety bracket installation
- Installation de l'équerre de sécurité
- Instalacion del escuadra de seguridad

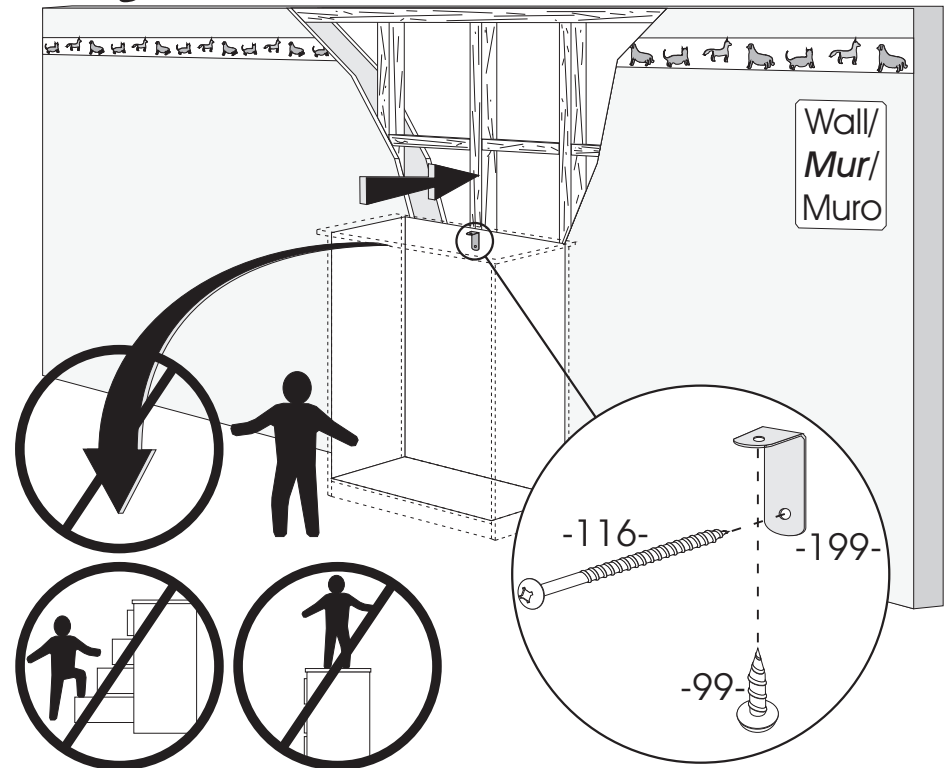

- TO PREVENT THE UNIT FALLING ON CHILDREN  
Locate a stud in the wall behind the unit. Screw -199- under the top with -99-. And through the back of the unit with -116- into the solid part of the wall.

- **POUR EMPÊCHER LE MEUBLE DE BASCULER SUR LES ENFANTS**  
Localiser un colombage, dans la largeur du meuble.  
Visser -199- sous le dessus du meuble avec -99-.  
Et à travers le dos du meuble avec -116-, dans la partie solide du mur.

- POR IMPEDIR EL MUEBLE QUE VOLCAR SOBRE LOS NINOS.  
Localizar uno entramado, en la anchura del meuble.  
Atornillar -199- debajo la pieza del encima con -99-.  
Y a través del dorso del mueble con -116-, en la parte solida del muro.

28

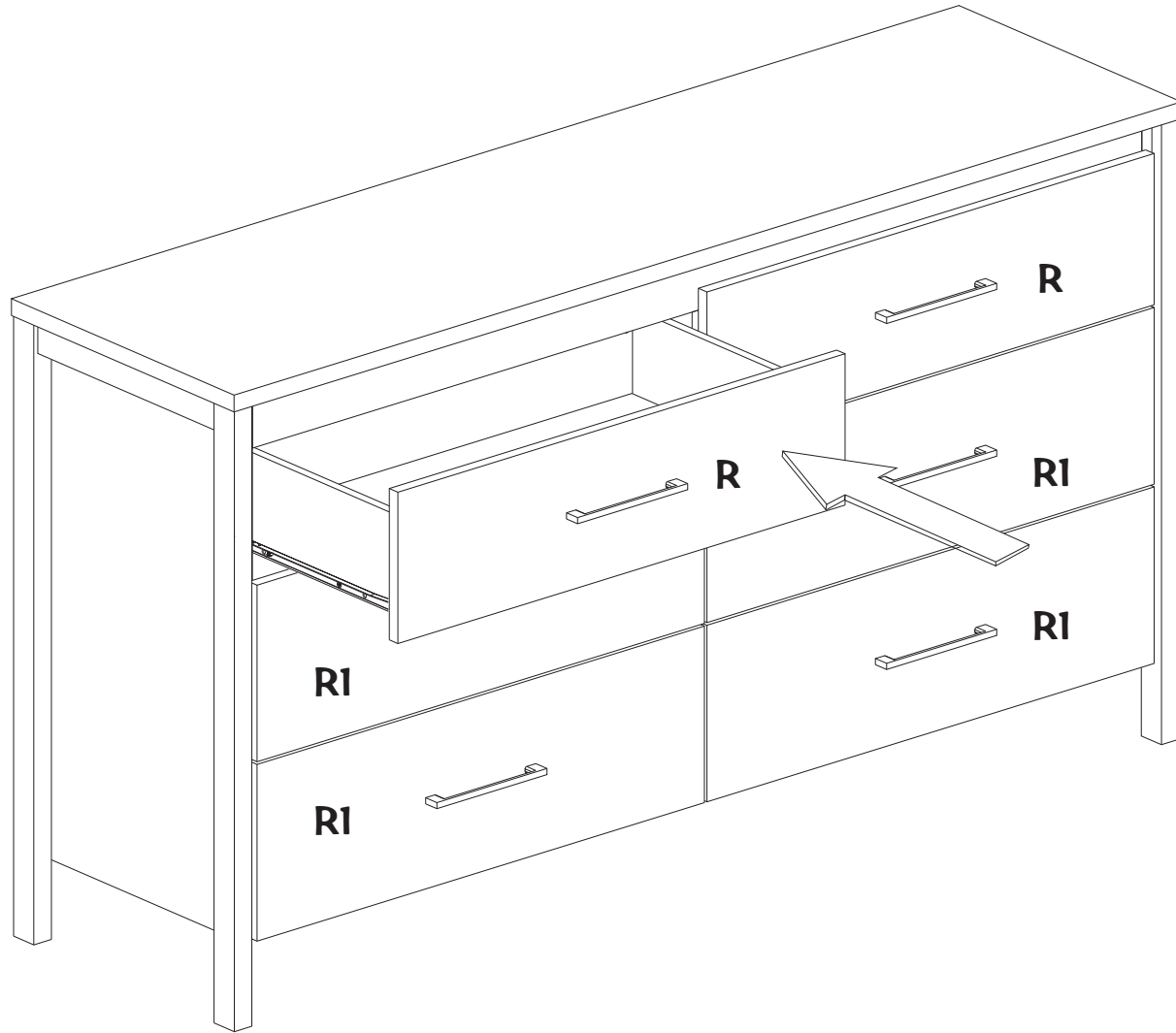

CUSTOMERS SERVICE/ SERVICE À LA CLIENTÈLE/ SERVICIO A LA CLIENTELA

If you have any difficulty assembling this unit, or to order replacement parts, do not hesitate to contact us.

Do not return any parts to the store, find the number(s) of the part(s) in the "Exploded view" or the "Hardware list", and CALL our customer service !



*Si vous éprouvez des difficultés à assembler les pièces, ou pour commander des pièces de remplacement, n'hésitez pas à communiquer avec nous.*

*Ne rapporter aucune pièce au magasin, repérez le(s) numéro(s) de(s) pièce(s) en question, dans la "Vue explosée" ou "la Liste de quincaillerie", et TÉLÉPHONEZ à notre service à la clientèle.*

Si el Ensamblaje del mueble presenta ciertas dificultades, o para enviarle unas piezas de reemplazo, no dude en llamarnos.

No traiga ninguna pieza al comercio.

Identifique el o los número(s) de la(s) pieza(s) en cuestión en "la Lista de ferretería" o la "visión de conjunto" y LLAME a nuestro servicio a la clientela.

 **1-800-290-0465** 

N.B.: Discard two end packing parts.

These are for protection during shipping.

N.B.: *Les pièces aux extrémités de la boîte ne vous sont d'aucune utilité pour l'assemblage du meuble. Ce ne sont que des protecteurs.*

N.B.: Las piezas en las extremidades de la caja son inútiles para ensamblar el mueble. Sirven únicamente para protegerlo.

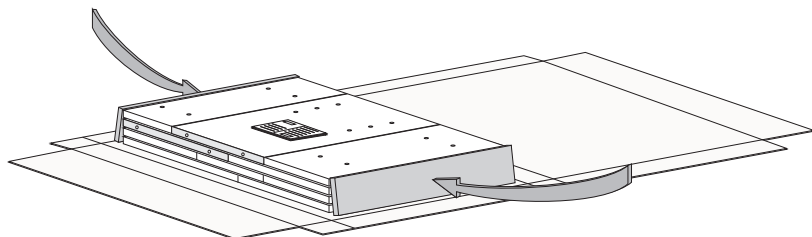

MAINTENANCE TIPS/CONSEILS D'ENTRETIEN/CONSEJOS DE MANUTENIMIENTO

- Never let liquids or damp cloths sit on this furniture.
- *Ne jamais laisser de liquide ou linge humide sur le meuble.*
- Nunca deje un líquido o un trapo húmedo sobre el mueble.



- Never use ammonia-based cleaning products, as they will damage the finish.
- *Ne jamais utiliser de nettoyeur à base d'ammoniaque, cela va endommager le fini.*
- Nunca utilice un producto de limpieza a base de amoníaco, esto dañará el acabado.



- To avoid dulling of the finish, do not place furniture in direct sunlight.
- *Ne pas placer le meuble directement au soleil pour prévenir le ternissement.*
- No exponga el mueble directamente al sol para prevenir empañamiento.

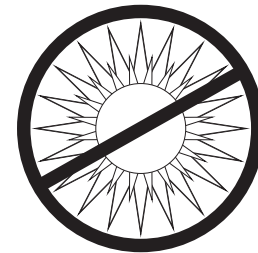

- Do not put plastic or rubber rings under appliances. Use cloth or felt protectors.
- *Évitez de déposer des appareils avec des rondelles de plastique ou de caoutchouc. Utilisez un protecteur en tissu ou en feutre.*
- Evite apoyar aparatos con redondeles de plástico o de goma. Utilizar un protector de tela o de fieltro.

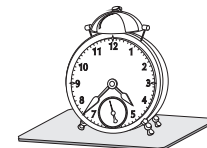

- To clean, use a soft or slightly damp cloth, then wipe with a clean, dry cloth.
- *Pour nettoyer, utilisez un linge doux ou légèrement humecté.*
- *Essuyez par la suite avec un linge propre et sec.*
- Para limpiar, utilice un trapo suave o ligeramente humedecido. Seque luego con un trapo limpio y seco.

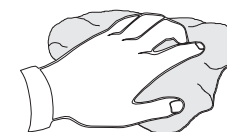

## 5 YEAR LIMITED WARRANTY

1. South Shore™ Furniture provides the original buyer with a warranty covering "defects" on furniture parts and workmanship for a period of 5 years from the date of purchase.
2. The word "defect" as used in this warranty is defined as any imperfection that may impair the intended use of the product.
3. This warranty is strictly limited to the repair or replacement of defective component parts, and excludes all other direct or indirect charges and expenses up to the limit permitted by law in your state/province.
4. In the case of a discontinued part or product, South Shore™ Furniture promises to reimburse the value of that part or product.
5. If a replacement part is unavailable, South Shore™ Furniture's liability to the buyer will not exceed the production cost of the part in question.
6. This warranty only applies under conditions of normal domestic use. It does not cover defects resulting from commercial use, intentional damage, negligence, abuse, product modification, accidents, exposure to the elements, or maintenance that does not comply with the guidelines on our website.
7. To honor this warranty, South Shore™ Furniture reserves the right to verify the grounds of any request and to ask for the original buyer's proof of purchase.
8. This warranty is only valid on purchases made at authorized South Shore™ Furniture retailers in Canada, the U.S., Mexico, Puerto Rico and Bermuda.
9. This warranty defines the limits of South Shore™ Furniture's liability, and entitles the original buyer to specific rights. Any warranty defined by law in your state/province is limited to a period of 5 years. If the law in your state/province prohibits this restriction, then it does not apply.
10. South Shore™ Furniture will not reimburse defective furniture, but will replace it with an item of equivalent value.

To qualify for your warranty, please take a moment to fill out our on-line registration form ([southshorefurniture.com](http://southshorefurniture.com))

*Afin de bénéficier de votre garantie, nous vous invitons à remplir le formulaire d'enregistrement en ligne ([meublesrivesud.com](http://meublesrivesud.com))*

Para obtener su garantía, tenga a bien llenar nuestro formulario en línea ([southshorefurniture.com](http://southshorefurniture.com))

## GARANTIE LIMITÉE DE 5 ANS

1. Meubles South Shore™MC garantit à l'acheteur original, pour une période de 5 ans à partir de la date d'achat, toutes les composantes des meubles contre les «défauts» de matériaux et de main-d'œuvre.
2. Le mot «défaut» utilisé dans cette garantie signifie une imperfection pouvant altérer l'utilité pour laquelle le produit est destiné.
3. Cette garantie se limite strictement à la réparation ou au remplacement des pièces composantes défectueuses. Cette garantie exclut tous les autres frais et dépenses directs ou indirects et ce, jusqu'à la limite permise par la législation en vigueur dans votre lieu de résidence.
4. Dans le cas d'une réclamation concernant un produit ou une pièce discontinuée, Meubles South Shore™MC s'engage à rembourser la valeur du produit ou de la pièce en question.
5. À défaut de pouvoir fournir la pièce de remplacement, la responsabilité de Meubles South Shore™MC ne peut excéder la valeur équivalente au coût de production de la pièce en litige.
6. Cette garantie s'applique sous des conditions d'usage domestique normal et ne couvre pas les défauts pouvant résulter d'un usage commercial, de dommages intentionnels, de la négligence, de l'usage abusif, de modifications personnelles, d'un accident, de l'exposition aux éléments ou d'un entretien ne respectant pas les conseils décrits sur notre site Internet.
7. Comme condition pour fournir une pièce de remplacement, Meubles South Shore™MC se réserve le droit de vérifier le fondement de la requête, de même que d'exiger la preuve d'achat de l'acheteur original.
8. Cette garantie n'est valide que si et seulement si l'achat a été effectué chez un marchand autorisé par Meubles South Shore™MC au Canada, aux États-Unis, au Mexique, à Puerto Rico et aux Bermudes.
9. Cette garantie définit les limites de la responsabilité de Meubles South Shore™MC et donne à l'acheteur original des droits spécifiques. Toute garantie législative prévalant dans votre lieu de résidence est limitée à une période de 5 ans. Si cette restriction n'est pas permise par la législation de votre lieu de résidence, elle ne s'applique pas.
10. Meubles South Shore™MC ne remboursera pas un meuble défectueux, mais le remplacera par un autre de valeur équivalente.

## GARANTIA LIMITADA DE 5 AÑOS



1. South Shore™MR garantizan al comprador original, por un período de 5 años a partir de la fecha de compra, todas las piezas que componen el mueble contra los «defectos» de material y mano de obra.
2. La palabra «defecto» utilizada en esta garantía se define como toda imperfección que pueda alterar la utilidad para la cual se destina el producto.
3. Esta garantía se limita estrictamente a la reparación o reemplazo de las piezas que tengan componentes defectuosos. Esta garantía no incluye cualquier gasto directo o indirecto hasta el límite permitido por la legislación vigente en su lugar de residencia.
4. En el caso de una reclamación referente a un producto o pieza discontinuada, South Shore™MR se compromete a reembolsar el valor del producto o pieza en cuestión.
5. A falta de poder suministrar la pieza de repuesto, la responsabilidad de South Shore™MR no puede exceder el valor equivalente al costo de producción de la pieza en litigio.
6. Esta garantía se aplica bajo las condiciones de uso doméstico normal y no cubre los defectos que puedan resultar de un uso comercial, daños intencionales, negligencia, uso abusivo, modificaciones personales, un accidente, exposición a los elementos y mantenimiento sin respetar los consejos que se describen en este sitio web.
7. Como condición para suministrar una pieza de repuesto, South Shore™MR se reservan el derecho de verificar el fundamento de la solicitud, así como de exigir la prueba de compra del comprador original.
8. Esta garantía sólo será válida si la compra se efectuó en un comercio autorizado por Muebles South Shore™MR de Canadá, Estados Unidos, México, Puerto Rico o las Bermudas.
9. Esta garantía define los límites de la responsabilidad de South Shore™MR y otorga al comprador original los derechos específicos. Cualquier garantía legislativa que prevalece en su lugar de residencia está limitada a un período de 5 años. Si esta restricción no está permitida por la legislación de su lugar de residencia, ésta no se aplica.
10. South Shore™MR no hará ningún reembolso por muebles defectuosos, pero le enviará uno de valor equivalente.

## CUSTOMERS SERVICE / SERVICE À LA CLIENTÈLE / SERVICIO A CLIENTELE

### **CANADA / USA**

 **1-800-290-0465** 

### **MEXICO**

 **01-800-522-6796**   
toll free number / lada sin costo

### **INTERNATIONAL**

 **418-926-2961** 



6168, Rue Principale  
SAINTE-CROIX, QUÉBEC  
CANADA, G0S 2H0



FAX: 1-877-586-5339  
(CANADA / USA)



E-MAIL: [service@southshore.ca](mailto:service@southshore.ca)  
WEB: [www.southshore.ca](http://www.southshore.ca)

