

ASSEMBLY INSTRUCTIONS

5 PC TRAY SET WITH MARBLE TOP

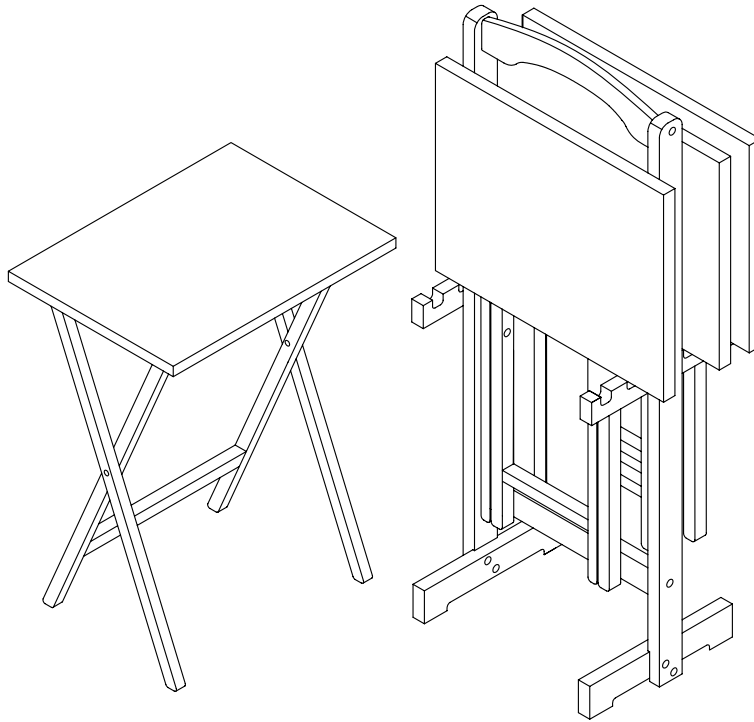



WE ARE HERE TO HELP!

IMPORTANT:
PLEASE READ ALL INSTRUCTIONS IN THIS BOOKLET BEFORE STARTING ASSEMBLY.
MADE IN VIETNAM

HARDWARE PACKAGE COUNT

OPEN HARDWARE PACKAGE ON A FLAT SURFACE COVERED WITH NEWSPAPER. COUNT EACH PIECE OF HARDWARE TO MATCH THE QUANTITY NUMBER IN THE HARDWARE LIST COLUMN. CALL CUSTOMER SERVICE IF ANY OF THE PARTS ARE MISSING. FOLLOW THE LETTER IDENTIFICATION WHEN READING THE ASSEMBLY DRAWING "A" THROUGH "C".

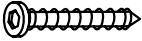
HARDWARE IDENTIFICATION

SYMBOL	GRAPHICS	DESCRIPTION	QTY
A	 Ø6.3 X 25 mm	WOOD SCREW	12
B		WOOD BUTTON	4
C		WRENCH	1

ALL PARTS ARE LABELED WITH STICKERS MATCHING THE PART IDENTIFICATION NUMBERS LISTED IN LEFT COLUMN.

IMPORTANT
PLEASE USE ALL THE HARDWARE MENTIONED ABOVE.
THEY WILL ASSURE THE ITEM STABILITY AND SAFETY.

TOOLS REQUIRED

A STANDARD PHILLIPS HEAD SCREWDRIVER (NOT PROVIDED) AND AN ALLEN WRENCH "C" (PROVIDED) ARE REQUIRED TO ASSEMBLE THIS UNIT. USE A PLASTIC HEAD Mallet, NOT PROVIDED, TO TAP IN STRETCHERS OR OTHER COMPONENTS.

PART IDENTIFICATION:

PARTS	DESCRIPTION	QTY
1	HANDLE	01
2	POST	02
3	HANGING BAR	02
4	CROSSBAR	01
5	BASE	02
6	TRAY TABLE	04

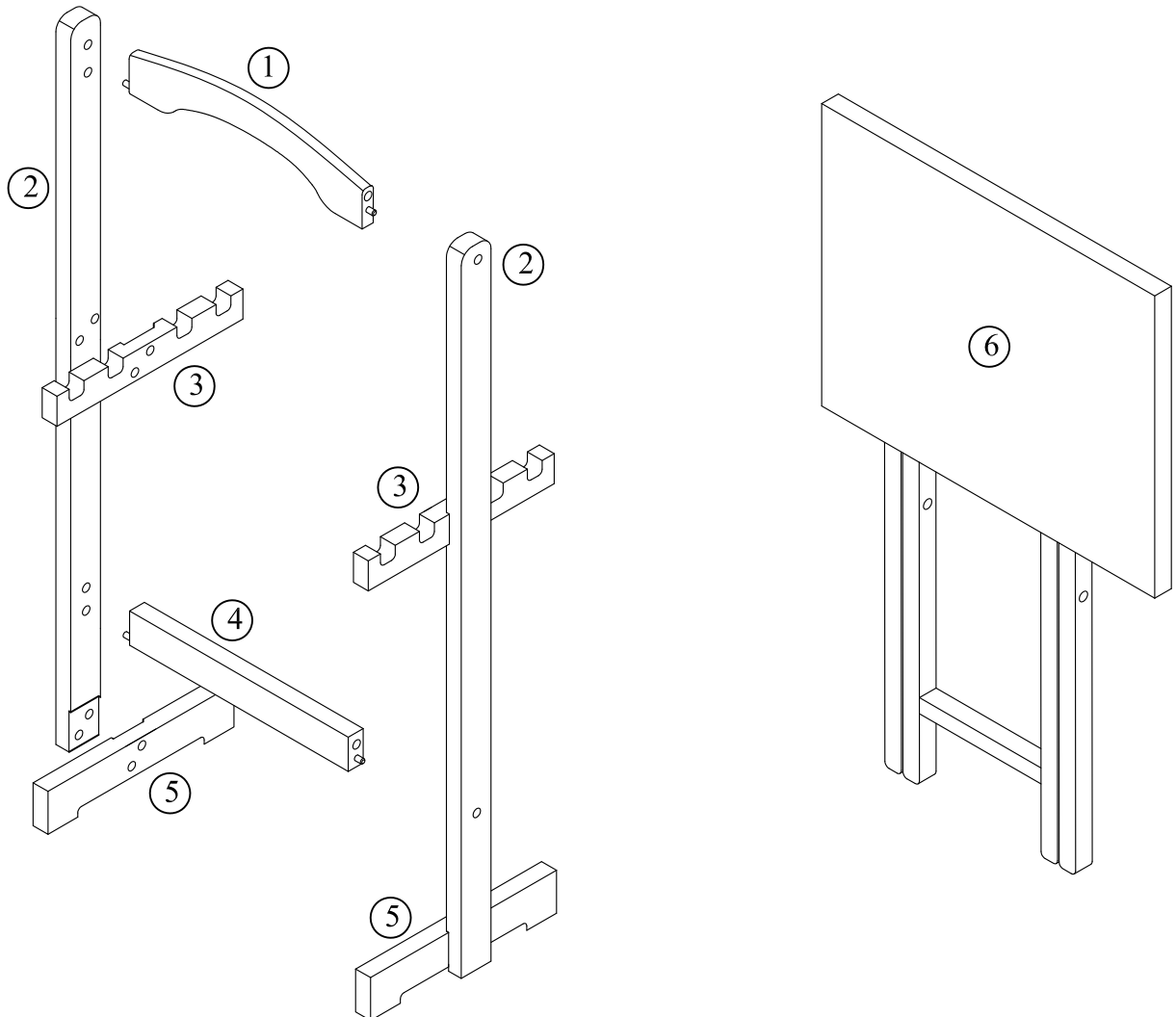

STEP 1:

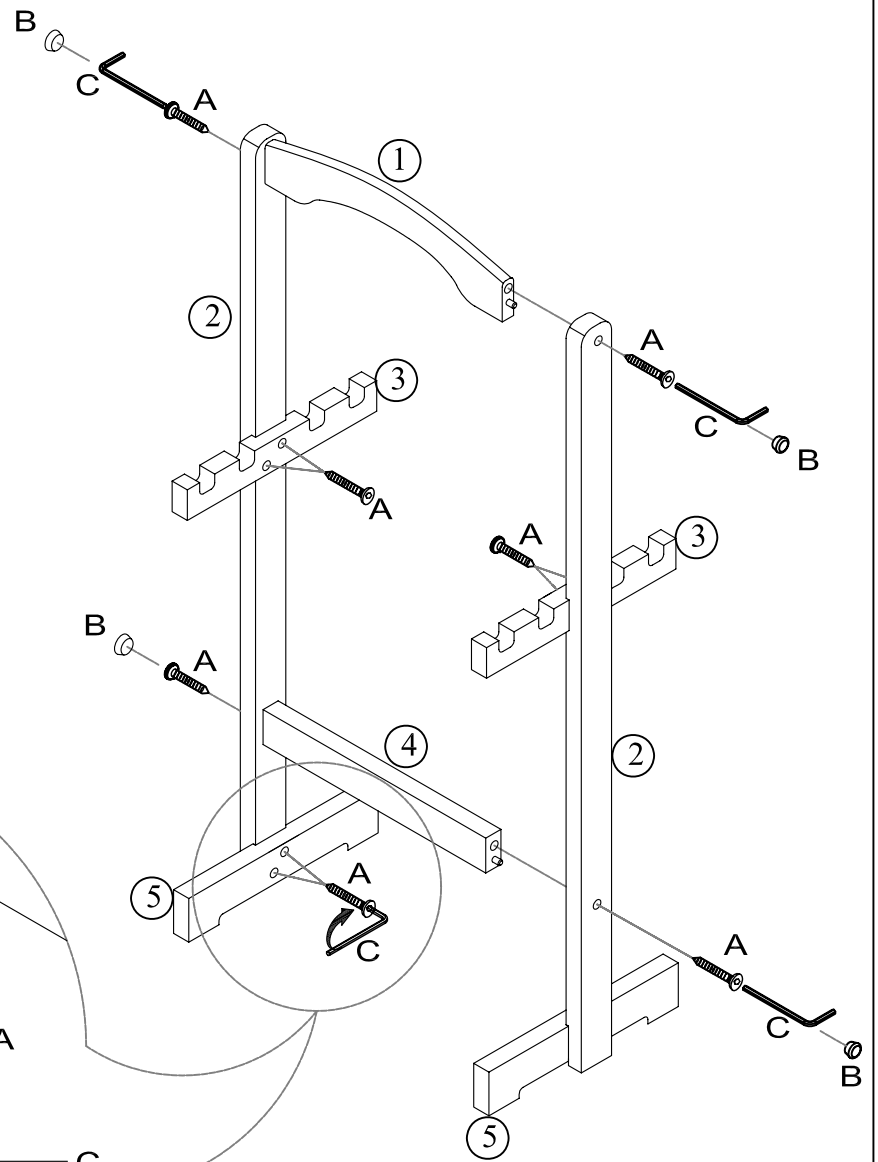

COMPLETED ASSEMBLY

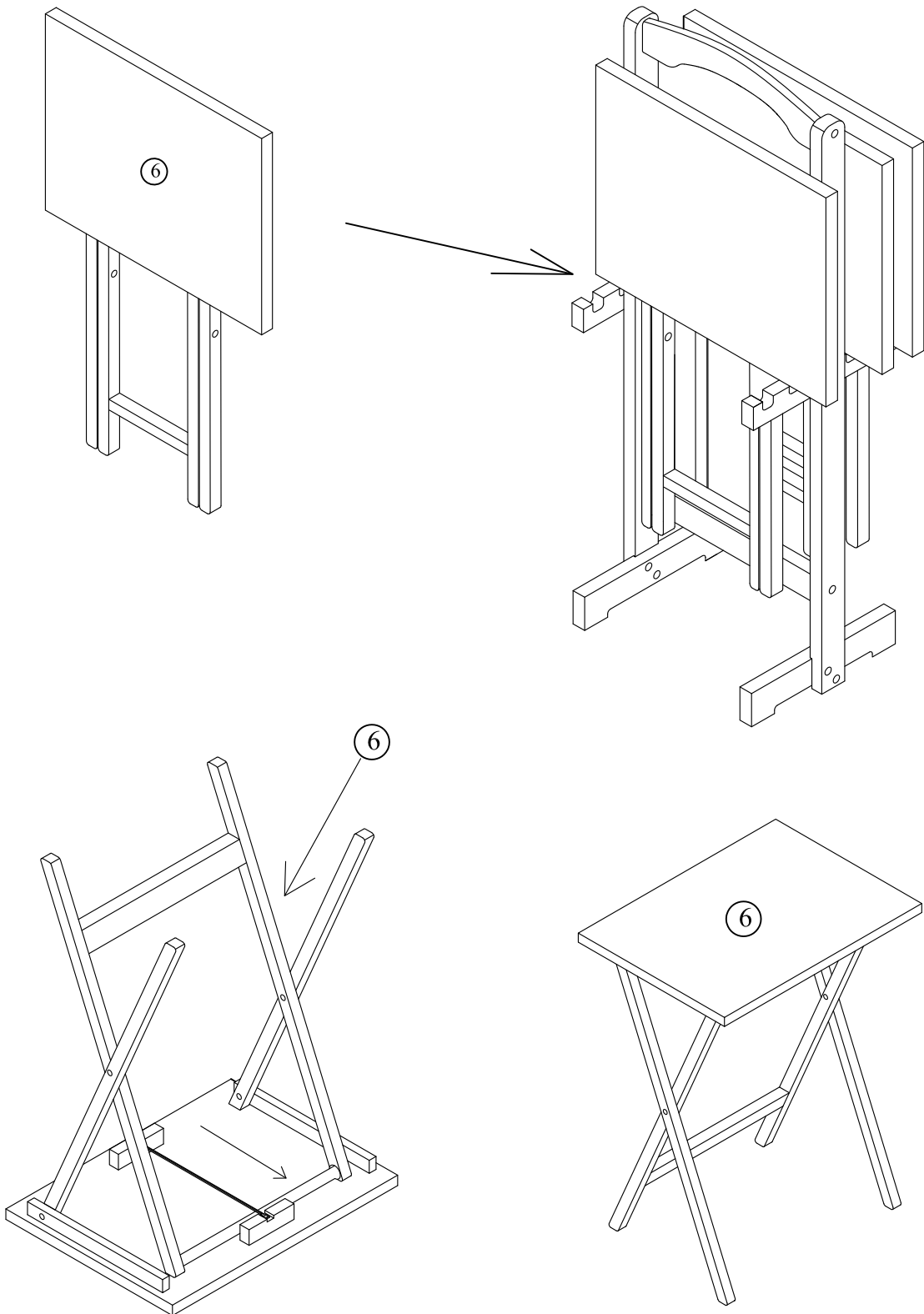

WARRANTY