

1. English: Two people corporation and keep screws a little loose during installation will be better.
2. Deutsch: Bei der Installation ist es besser, wenn zwei Personen zusammenarbeiten und die Schrauben ein wenig locker halten.
3. Français: Lors de l'installation, il est préférable que deux personnes travaillent ensemble et tiennent les vis de manière un peu lâche.
4. Italiano: È meglio che la corporazione sia composta da due persone e che le viti siano un po' allentate durante l'installazione.
5. Español: Dos personas corporación y mantener los tornillos un poco flojo durante la instalación será mejor.
6. Português: Corporação de duas pessoas e Manter os parafusos um pouco soltos durante a instalação será melhor.
7. ل.ضفأنوكستبثتلءانثأللقفةضافضيغاربلأىلعظافحلاونصخشةكرش:ةبرعلا.
8. 日本語: 2人で協力し、ネジを少し緩めておくと取り付けやすい。

## Components

AX8

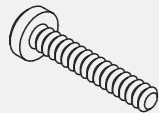

M6X35

BX12

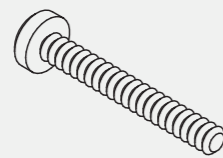

M6X45

CX4

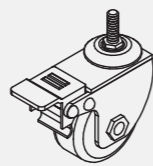

DX1



EX1

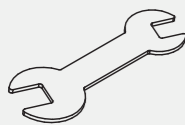

① x1

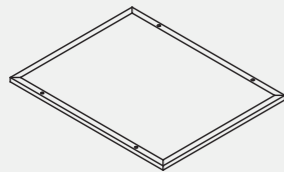

② x2

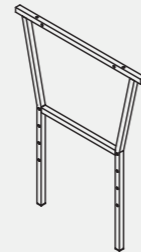

③ x2

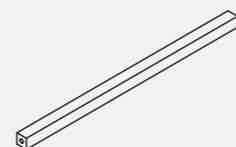

④ x1

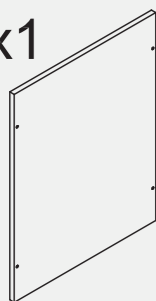

⑤ x2

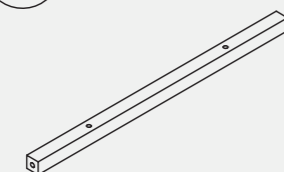

⑥ x1

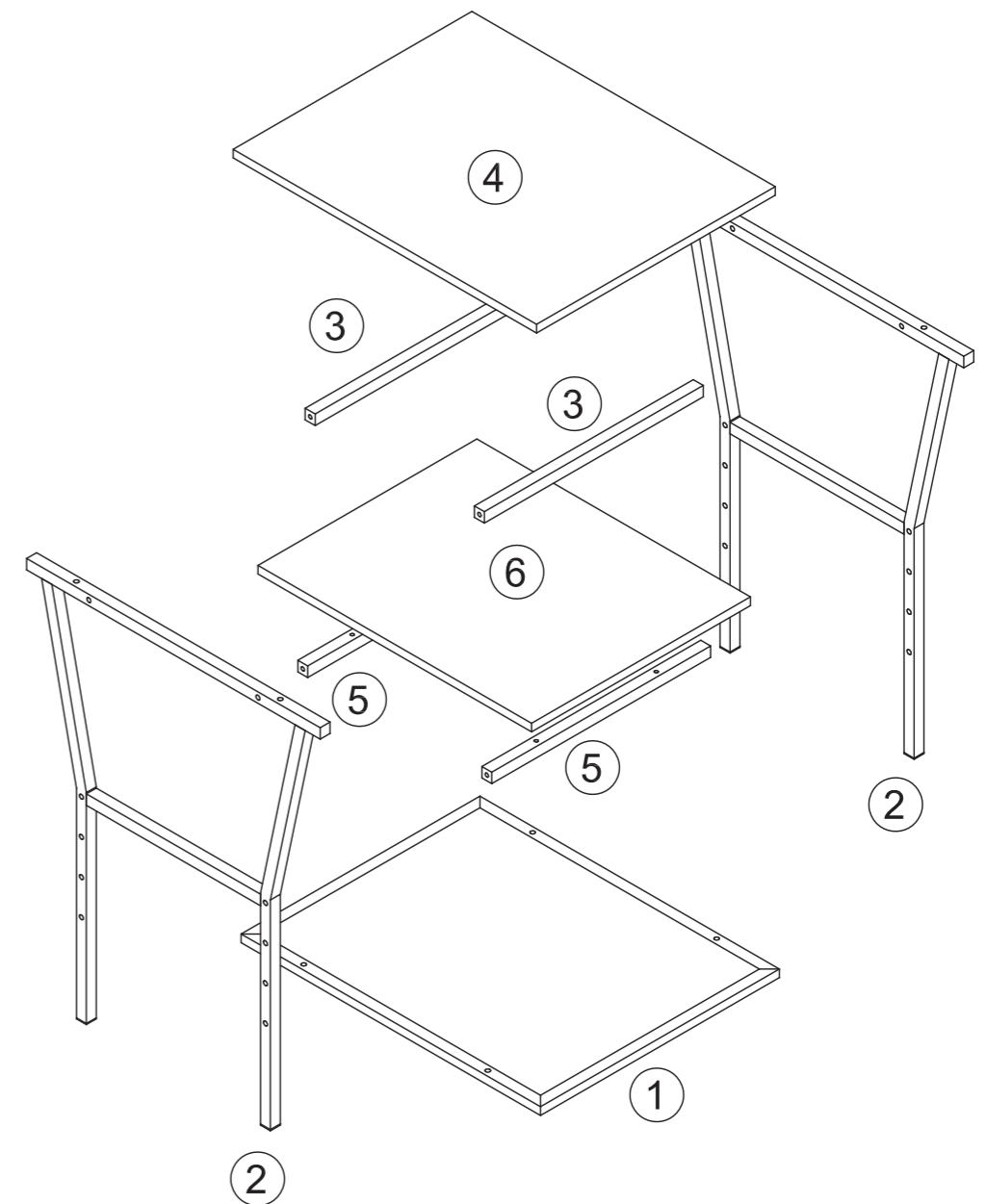
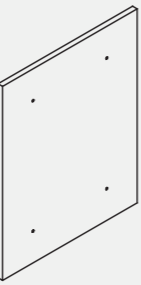

1.

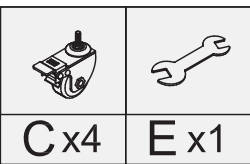

Press and hold the brake, then directly screw the wheels on

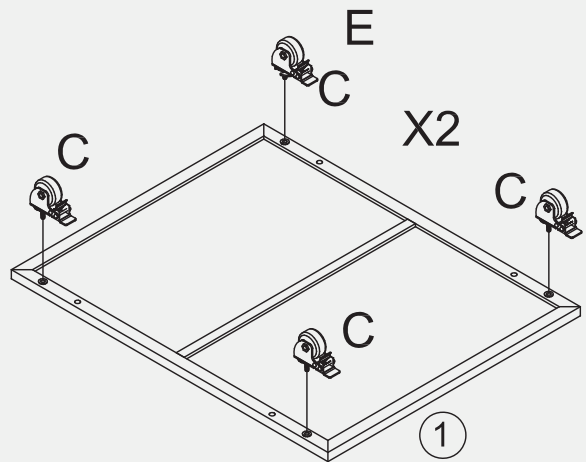

2.

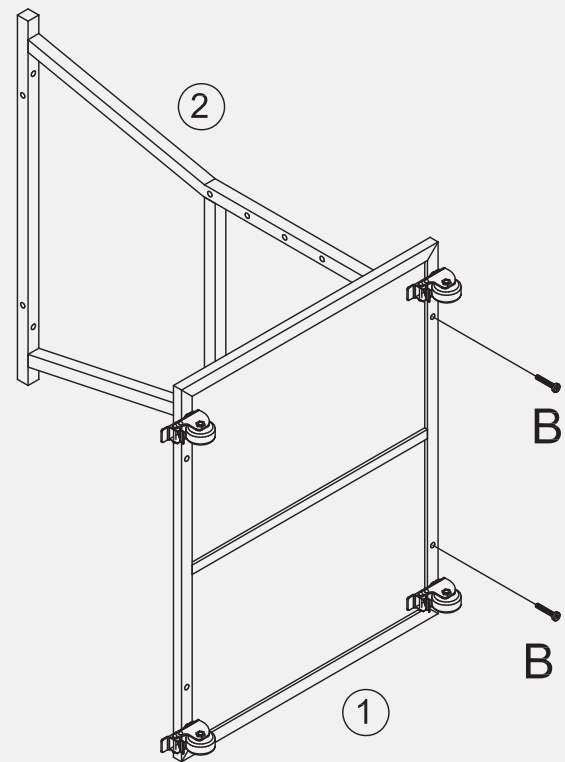
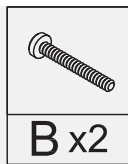

3.

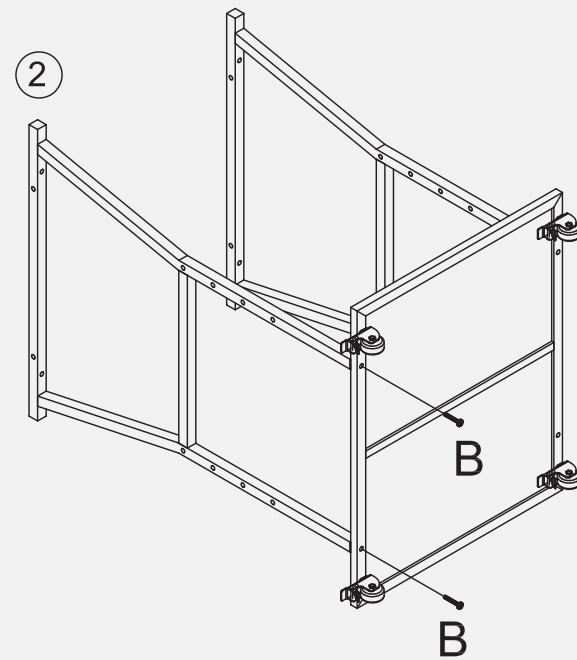
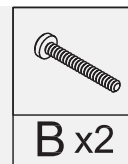

4.

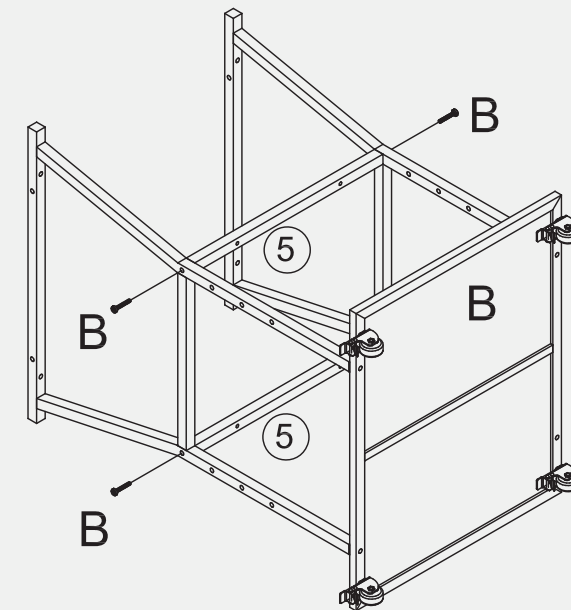
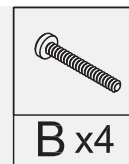

5.

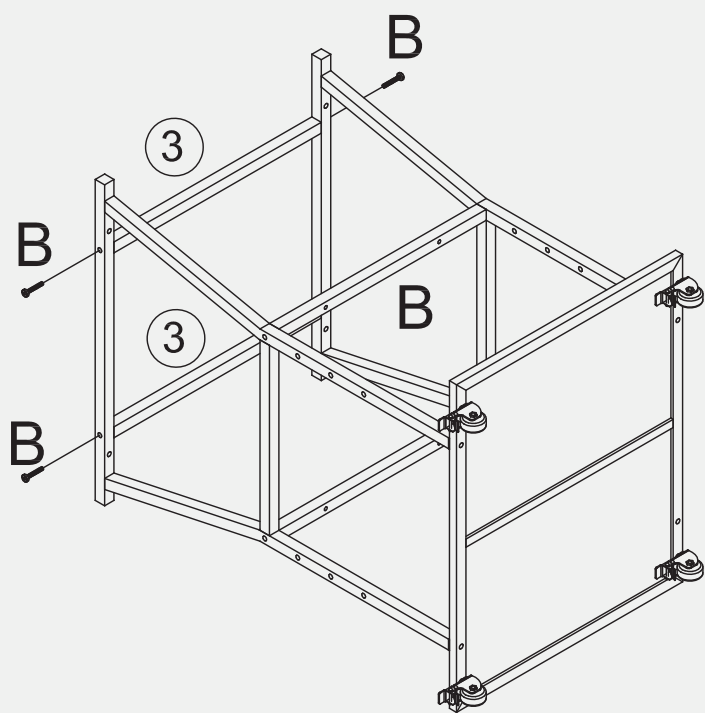
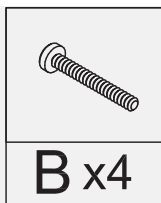

6.

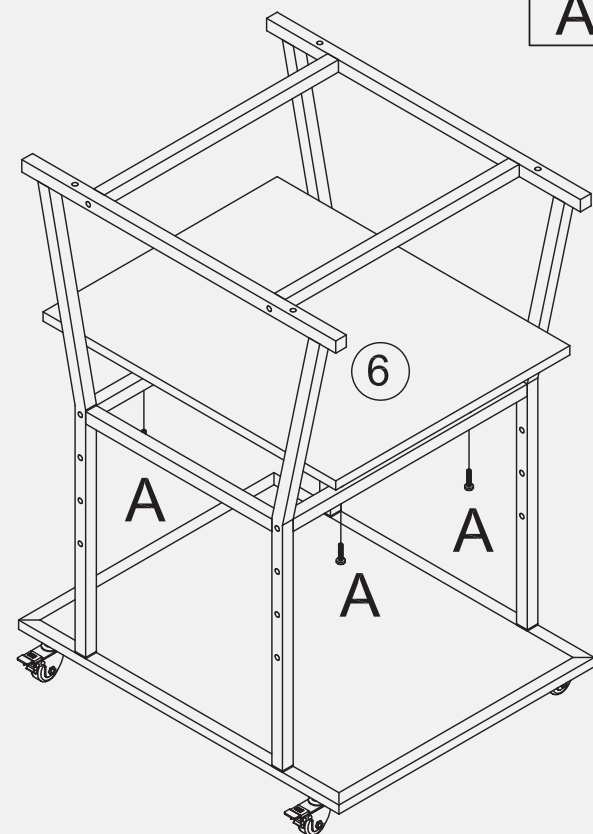
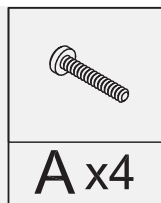

7.

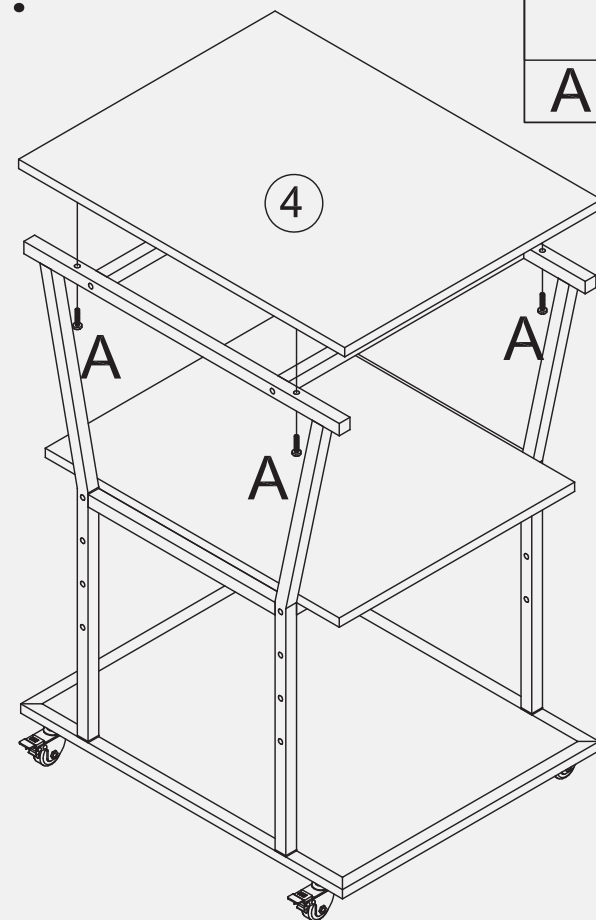
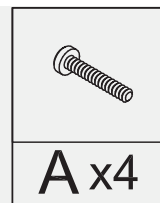

8.

